

■ Features :

- Universal AC input / Full range
- AC input active surge current limiting
- Built-in active PFC function, PF>0.95
- Protections: Short circuit / Overload / Over voltage/Over temperature
- Forced air cooling by built-in DC Fan
- Built-in remote ON-OFF function for CH3,CH4 and the whole unit
- Isolate output
- Built-in remote sense function(CH3,CH4)
- Built-in external voltage control function(CH3,CH4)
- Built-in output current monitor signal(CH3,CH4)

SPECIFICATION

MODEL		QP-1000			
OUTPUT	OUTPUT NUMBER	CH1	CH2	CH3	CH4
	DC VOLTAGE	12V	5V	24V	24V
	RATED CURRENT	8.4A	6A	12.5A	25A
	CURRENT RANGE	0 ~ 8.4A	0 ~ 6A	0 ~ 12.5A	0 ~ 25A
	RATED POWER (convection)	130.8W(max.) 1000W(max.)		300W	600W
	RIPPLE & NOISE (max.) Note.2	120mVp-p	80mVp-p	100mVp-p	200mVp-p
	VOLTAGE ADJ. RANGE	10.8 ~ 13.2V	4.5 ~ 5.5V	21.5 ~ 26.5V	21.5 ~ 26.5V
	REMOTE PROGRAMMING (PV)	CH3,CH4 10% ~ 120% adjustable by 0.5 ~ 6VDC external control			
	VOLTAGE TOLERANCE Note.3	±2.0%	±2.0%	±1.0%	±1.0%
	LINE REGULATION	±0.5%	±0.5%	±0.5%	±0.5%
	LOAD REGULATION	±1.0%	±1.0%	±1.0%	±1.0%
	SETUP, RISE TIME	1500ms, 50ms/230VAC	1500ms, 50ms/115VAC at full load		
	HOLD UP TIME (Typ.)	16ms/230VAC	16ms/115VAC at full load		
	INPUT	VOLTAGE RANGE Note.5	90 ~ 264VAC	127 ~ 370VDC	
FREQUENCY RANGE		47 ~ 63Hz			
POWER FACTOR		PF ≥ 0.95/230VAC	PF ≥ 0.97/115VAC at full load		
EFFICIENCY(Typ.)		86%			
AC CURRENT (Typ.)		12A/115VAC	6A/230VAC		
INRUSH CURRENT (Typ.)		COLD START 25A/115VAC	40A/230VAC		
LEAKAGE CURRENT		<2mA / 240VAC			
PROTECTION	OVERLOAD	105 ~ 135% rated output power CH1, CH2 : Protection type : Shut down o/p voltage, re-power on to recover CH3, CH4 : Protection type : Constant current limiting, unit will shut down after 3 sec., re-power on to recover			
	OVER VOLTAGE	13.8 ~ 16.2V	5.75 ~ 6.75V	30 ~ 34.8V	30 ~ 34.8V
		Protection type : Shut down o/p voltage, re-power on to recover			
	OVER TEMPERATURE	75°C ±5°C detect on heatsink of power transistors Protection type : Shut down o/p voltage, recovers automatically after temperature goes down			
FUNCTION	REMOTE CONTROL	Turn ON/OFF CH3,CH4 and the whole power supply RC+/RC-: Short , Power ON ; RC+/RC-: Open , Power OFF			
	CURRENT MONITOR	Signal provides an output of 0 ~ 5V which applies over 10 ~ 100% of rated load.			
	OUTPUT VOLTAGE EXTERNAL CONTROL	Please see the Function Manual			
ENVIRONMENT	WORKING TEMP.	-20 ~ +70°C (Refer to output load derating curve)			
	WORKING HUMIDITY	20 ~ 90% RH non-condensing			
	STORAGE TEMP., HUMIDITY	-40 ~ +85°C, 10 ~ 95% RH			
	TEMP. COEFFICIENT	±0.03%/°C (0 ~ 45°C)			
	VIBRATION	10 ~ 500Hz, 5G 10min./1cycle, period for 60min. each along X, Y, Z axes			
SAFETY & EMC (Note 4)	SAFETY STANDARDS	Design refer to UL60950-1, TUV EN60950-1			
	WITHSTAND VOLTAGE	I/P-O/P:3KVAC I/P-FG:1.5KVAC O/P-FG:0.5KVAC			
	ISOLATION RESISTANCE	I/P-O/P, I/P-FG, O/P-FG:100M Ohms/500VDC / 25°C / 70% RH			
	EMI CONDUCTION & RADIATION	Compliance to EN55022 (CISPR22)			
	HARMONIC CURRENT	Compliance to EN61000-3-2,-3			
	EMS IMMUNITY	Compliance to EN61000-4-2,3,4,5,6,8,11; ENV50204, EN55024, EN61000-6-2, EN61204-3			
OTHERS	MTBF	K hrs min. MIL-HDBK-217F (25°C)			
	DIMENSION	278*177.8*63.5mm (L*W*H)			
	PACKING	Kg			
NOTE	<ol style="list-style-type: none"> 1. All parameters NOT specially mentioned are measured at 230VAC input, rated load and 25°C of ambient temperature. 2. Ripple & noise are measured at 20MHz of bandwidth by using a 12" twisted pair-wire terminated with a 0.1uf & 47uf parallel capacitor. 3. Tolerance : includes set up tolerance, line regulation and load regulation. 4. The power supply is considered a component which will be installed into a final equipment. The final equipment must be re-confirmed that it still meets EMC directives. 5. Derating may be needed under low input voltage. Please check the derating curve for more details. 				

Mechanical Specification

Case No. Unit:mm

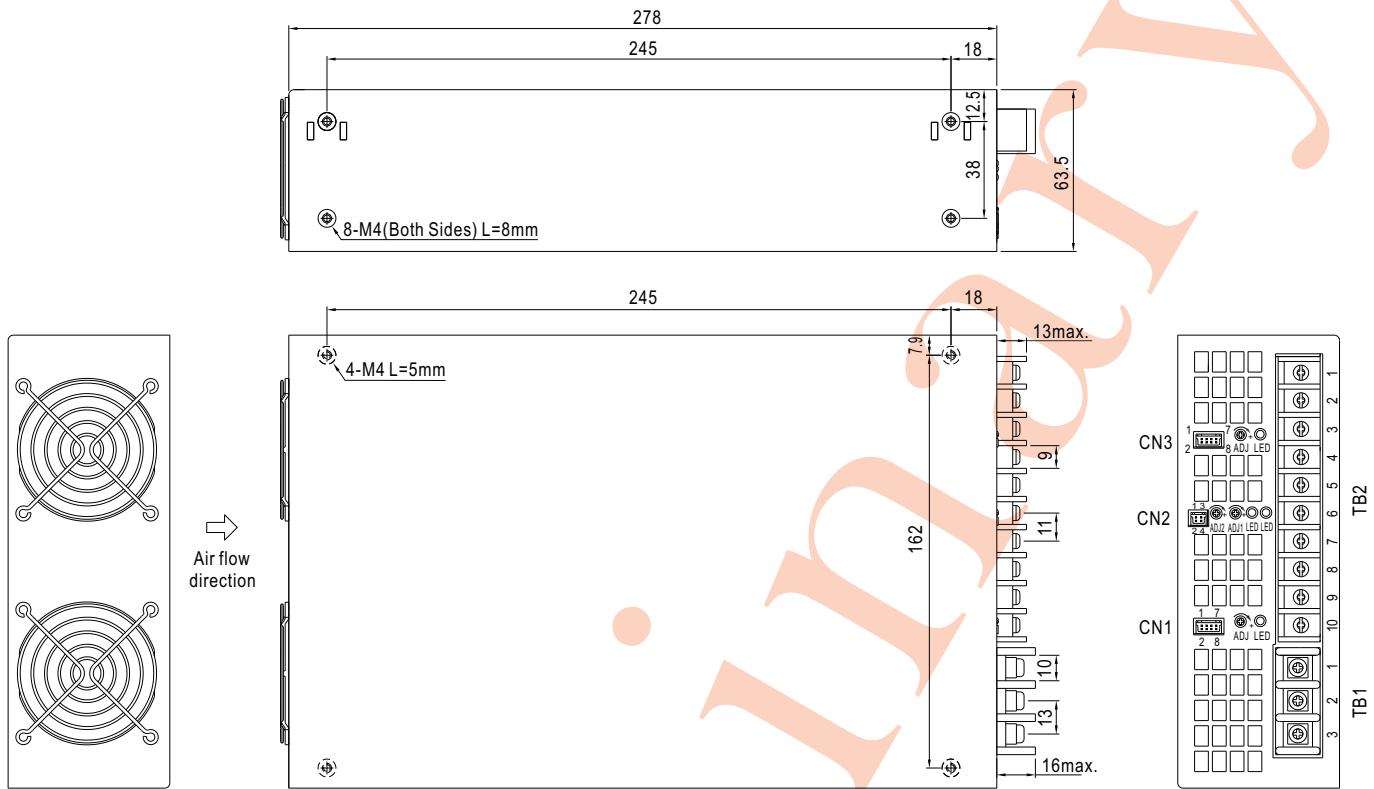

AC Input Terminal Pin No. Assignment (TB1)

Pin No.	Assignment
1	FG \perp
2	AC/N
3	AC/L

DC Output Terminal Pin No. Assignment (TB2)

Pin No.	Assignment	Pin No.	Assignment
1,2	+V4	7	-V2
3,4	-V4	8	+V2
5	+V1	9	+V3
6	-V1	10	-V3

Control Pin No. Assignment(CN1) for CH3: HRS DF11-8DP-2DS or equivalent

Pin No.	Assignment	Pin No.	Assignment	Mating Housing	Terminal
1	+S	5	PV	HRS DF11-8DS or equivalent	HRS DF11-**SC or equivalent
2	-S	6	Im		
3	+RC	7,8	G		
4	PS				

+S : +Remote Sensing PV : Voltage Control
 -S : -Remote Sensing Im : Output Current Monitor
 +RC : +Remote OF/OFF G : GND
 PS : Reference Voltage Terminal

Control Pin No. Assignment(CN2): HRS DF11-4DP-2DS or equivalent

Pin No.	Assignment	Mating Housing	Terminal
1	VCC	HRS DF11-4DS or equivalent	HRS DF11-**SC or equivalent
2	+RC		
3,4	COM		

+RC : +Remote OF/OFF
 VCC : 12V/0.1A auxiliary output for remote control

Control Pin No. Assignment(CN3) for CH4: HRS DF11-8DP-2DS or equivalent

Pin No.	Assignment	Pin No.	Assignment	Mating Housing	Terminal
1	+S	5	PV	HRS DF11-8DS or equivalent	HRS DF11-**SC or equivalent
2	-S	6	Im		
3	+RC	7,8	G		
4	PS				

+S : +Remote Sensing PV : Voltage Control
 -S : -Remote Sensing Im : Output Current Monitor
 +RC : +Remote OF/OFF G : GND
 PS : Reference Voltage Terminal

■ Block Diagram

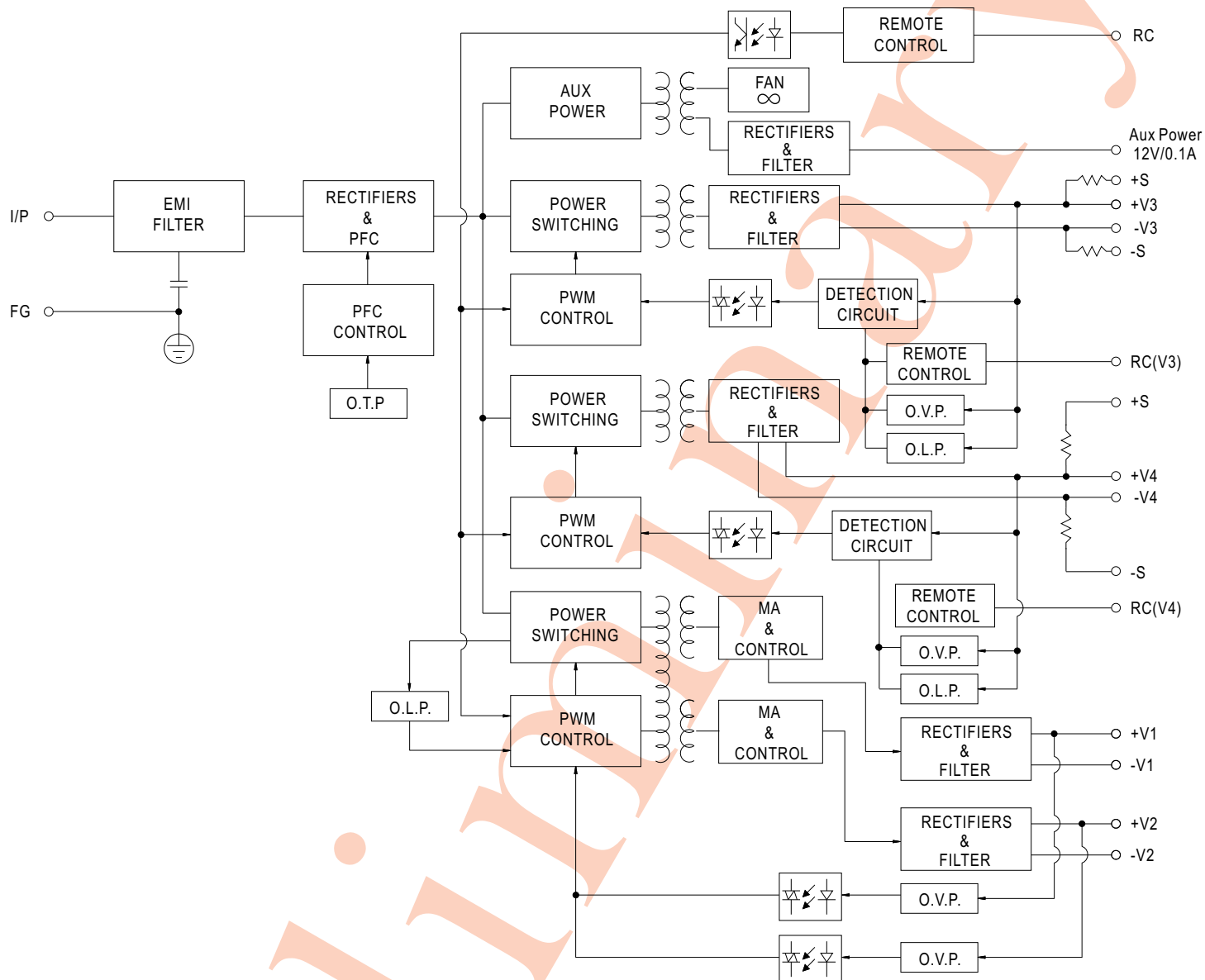

■ Derating Curve

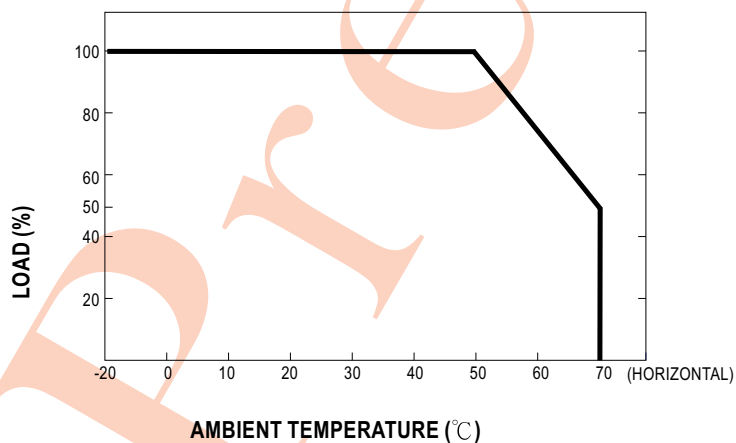

■ Output Derating VS Input Voltage

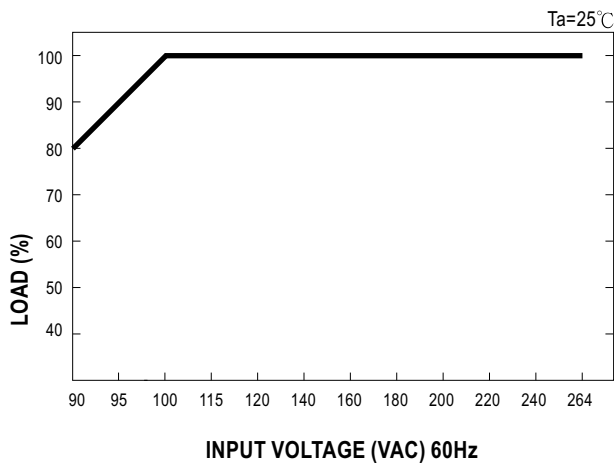

Function Manual

1. Remote ON/OFF

The PSU by using the "Remote ON/OFF" function

A. For CH3 (CN1) or CH4 (CN3)

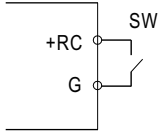

Between +RC(pin3) and G(pin7,8)	Output Status
SW ON (Short)	ON
SW OFF (Open)	OFF

B. For CH1 ~ CH4 (CN2)

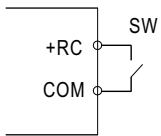

Between +RC(pin1) and COM(pin2,4)	Output Status
SW ON (Short)	ON
SW OFF (Open)	OFF

2. External Voltage Control by CH3, CH4

