

DO NOT SCALE FROM THIS PRINT

NOTES:

1. USE ASP-103597-01-B BODY FOR NON-STANDARD 19 POSITION.
2. Ⓞ REPRESENTS A CRITICAL DIMENSION.
3. BURR ALLOWANCE: .0005[0.013] MAX.
4. MINIMUM PUSHOUT FORCE: .5 LB.
5. MAXIMUM ALLOWABLE BOW: .002[0.05] INCH/INCH AFTER ASSEMBLY.
6. CONTACT TO BE FLUSH ±.002[0.05].
7. ONE REEL MINIMUM PLATING REQUIREMENT (85,000 CONTACTS PER REEL).
8. ALL DIMS TO BE SYMMETRICAL ABOUT THE CENTERLINE WITHIN ±.001 [0.03].
9. MAXIMUM VARIATION BETWEEN SOLDERBALLS: .0025[0.064]
10. REFER TO VISUAL INSPECTION BOARD FOR SOLDERBALL APPEARANCE CHECKS.
11. THE DISTANCE FROM THE CENTER OF ANY SOLDERBALL TO THE CENTER OF ANY ADJACENT INNER PEG SHALL BE .025±.005[0.64±0.13].
12. PARTS TO BE PACKAGED IN TAPE & REEL. FOR QTY'S LESS THAN 125 PCS, NO TRAILER OR LEADER WILL BE SUPPLIED.
13. **LEAD FREE SOLDER BALLS.**

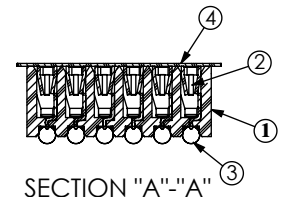
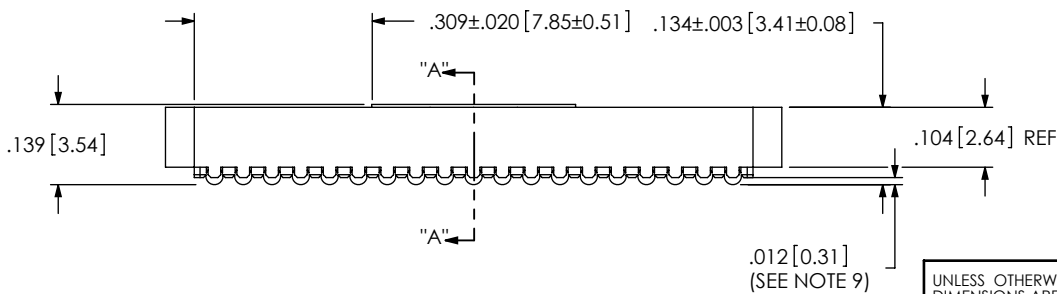
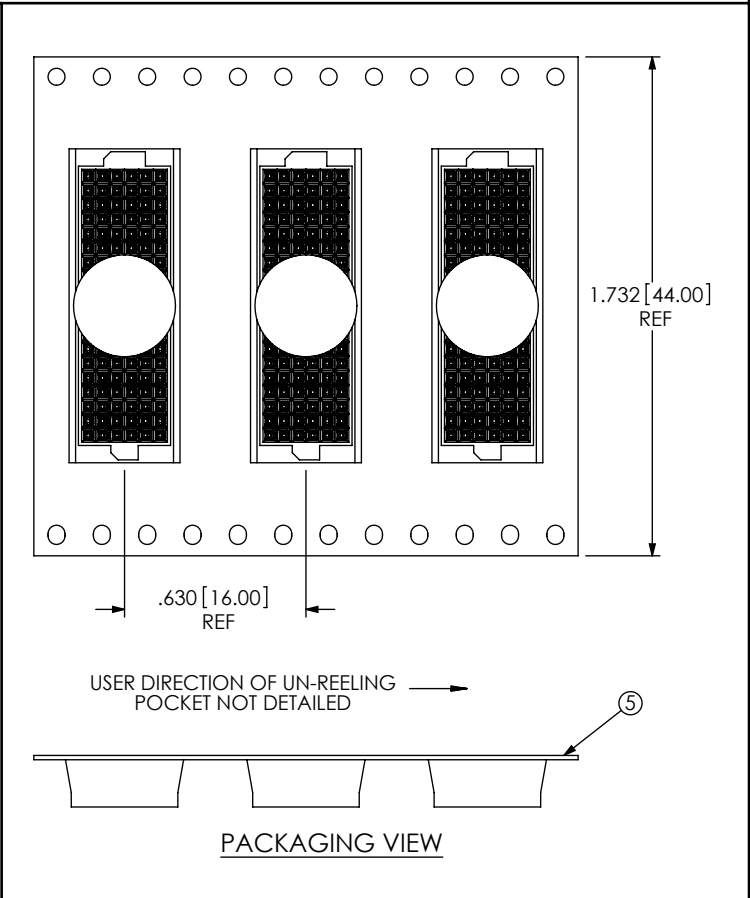
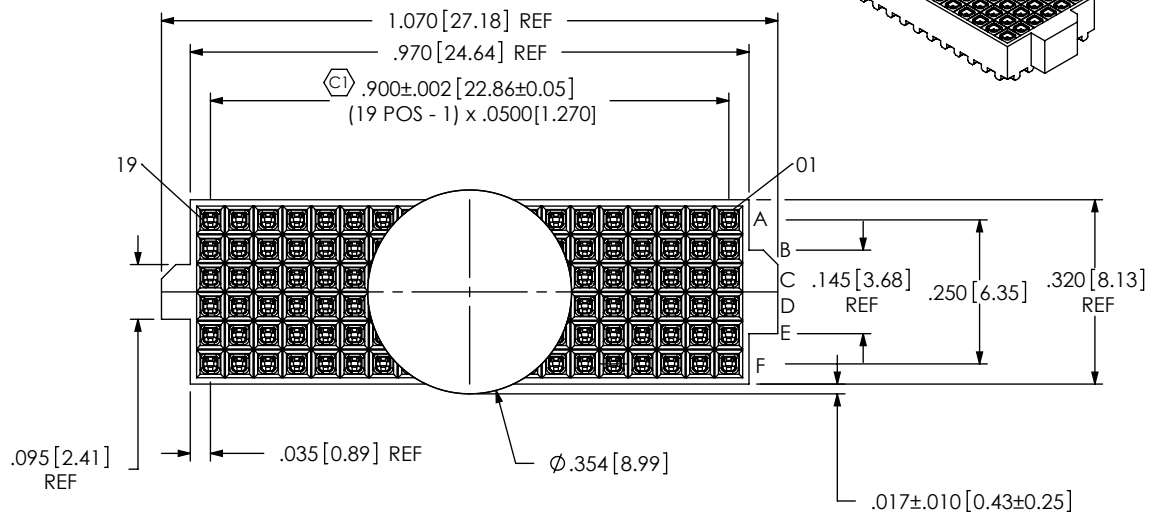
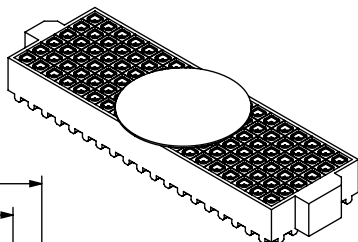

ITEM NO.	PART NUMBER	QUANTITY	MATERIAL
1	ASP-103597-01-B	1.0000	UL 94 V0, COLOR: BLACK
2	C-140-03-H	114.00	PHOS BRONZE, 521 HARD TEMPER
3	SDB-030-9653	114.00	96.5% Sn/3% Ag/.5% Cu
4	K-850-650	1.0000	POLYIMIDE FILM
5	CT-ASP1132MS	1.0000	CONDUCTIVE POLYMER

UNLESS OTHERWISE SPECIFIED, DIMENSIONS ARE IN INCHES. TOLERANCES ARE:
 DECIMALS ANGLES
 .XX: ±.01 2°
 .XXX: ±.005
 .XXXX: ±.0020

PROPRIETARY NOTE
 THIS DOCUMENT CONTAINS INFORMATION CONFIDENTIAL AND PROPRIETARY TO SAMTEC, INC. AND SHALL NOT BE REPRODUCED OR TRANSFERRED TO OTHER DOCUMENTS OR DISCLOSED TO OTHERS OR USED FOR ANY PURPOSE OTHER THAN THAT WHICH IT WAS OBTAINED WITHOUT THE EXPRESSED WRITTEN CONSENT OF SAMTEC, INC.

DO NOT SCALE DRAWING SHEET SCALE: 3:1

PLATING:
 CONTACT AREA: .000030 GOLD OVER .000050 NICKEL
 REMAINDER: .000003 FLASH GOLD OVER .000050 NICKEL

F:\DWG\MISC\MKTG\ASP-103612-02-MKT.SLDDRW

samtec
 520 PARK EAST BLVD, NEW ALBANY, IN 47150
 PHONE: 812-944-6733 FAX: 812-948-5047
 e-Mail: info@SAMTEC.com code 55322

DESCRIPTION:
 VITA 42 (LEAD FREE) SOCKET ASSEMBLY

DWG. NO.
ASP-103612-02

BY: WHELAN 09/12/06 SHEET 1 OF 2

RECOMMENDED BOARD LAYOUT

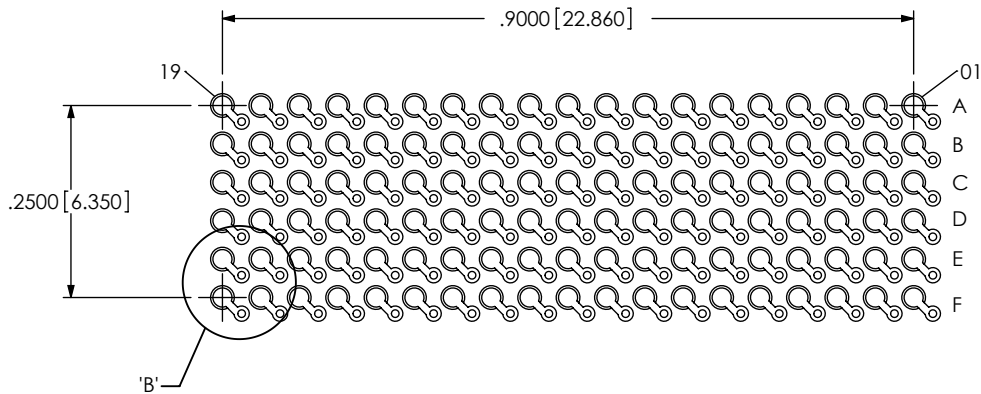

NOTE:
OUTER ROWS MAY NOT NEED VIAS - THIS IS LEFT TO
THE DISCRETION OF THE BOARD DESIGNER.

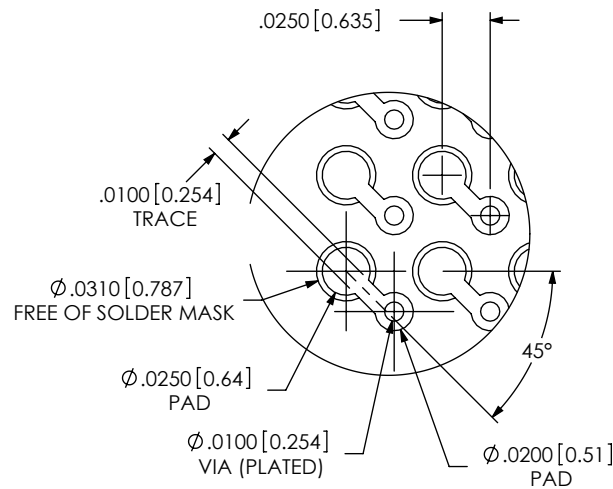

DETAIL 'B'
SCALE TO: 1

RECOMMENDED STENCIL LAYOUT
STENCIL TO BE .0060 [0.152] THICK

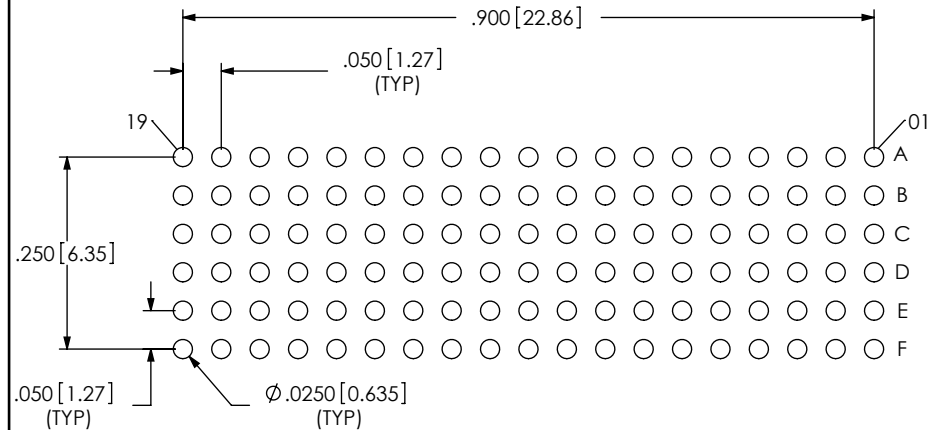

PROPRIETARY NOTE

THIS DOCUMENT CONTAINS INFORMATION
CONFIDENTIAL AND PROPRIETARY TO
SAMTEC, INC. AND SHALL NOT BE REPRODUCED
OR TRANSFERRED TO OTHER DOCUMENTS OR
DISCLOSED TO OTHERS OR USED FOR ANY
PURPOSE OTHER THAN THAT WHICH IT WAS
OBTAINED WITHOUT THE EXPRESSED WRITTEN
CONSENT OF SAMTEC, INC.



520 PARK EAST BLVD, NEW ALBANY, IN 47150
PHONE: 812-944-6733 FAX: 812-948-5047
e-Mail: info@SAMTEC.com code 55322

SHEET SCALE: 4:1

DESCRIPTION:
VITA 42 (LEAD FREE) SOCKET ASSEMBLY

DWG. NO.
ASP-103612-02