



**MOTOROLA**  
*intelligence everywhere™*

*digital dna™*

**Freescale Semiconductor, Inc.**

*MC68HC908LJ24*  
*MC68HC908LK24*

*Data Sheet*

*M68HC08*  
*Microcontrollers*

*MC68HC908LJ24/D*  
*Rev. 2*  
*8/2003*

*MOTOROLA.COM/SEMICONDUCTORS*

**Freescale Semiconductor, Inc.**

**Freescale Semiconductor, Inc.**

**For More Information On This Product,  
Go to: [www.freescale.com](http://www.freescale.com)**

# **MC68HC908LJ24**

# **MC68HC908LK24**

## **Data Sheet**

---

---

To provide the most up-to-date information, the revision of our documents on the World Wide Web will be the most current. Your printed copy may be an earlier revision. To verify you have the latest information available, refer to:

<http://motorola.com/semiconductors/>

The following revision history table summarizes changes contained in this document. For your convenience, the page number designators have been linked to the appropriate location.

Motorola and the Stylized M Logo are registered trademarks of Motorola, Inc.  
DigitalDNA is a trademark of Motorola, Inc.  
This product incorporates SuperFlash® technology licensed from SST.

© Motorola, Inc., 2003

**Revision History**

<b>Date</b>	<b>Revision Level</b>	<b>Description</b>	<b>Page Number(s)</b>
8/2003	2	First general release.	—

## List of Sections

Section 1. General Description .....	37
Section 2. Memory Map .....	49
Section 3. Random-Access Memory (RAM) .....	67
Section 4. FLASH Memory (FLASH) .....	69
Section 5. Configuration Registers (CONFIG) .....	79
Section 6. Central Processor Unit (CPU) .....	85
Section 7. Oscillator (OSC) .....	103
Section 8. Clock Generator Module (CGM).....	109
Section 9. System Integration Module (SIM) .....	139
Section 10. Monitor ROM (MON) .....	163
Section 11. Timer Interface Module (TIM).....	193
Section 12. Real Time Clock (RTC) .....	217
Section 13. Infrared Serial Communications Interface Module (IRSCI) .....	245
Section 14. Serial Peripheral Interface Module (SPI) ..	287
Section 15. Multi-Master IIC Interface (MMIIC) .....	319
Section 16. Analog-to-Digital Converter (ADC) .....	333
Section 17. Liquid Crystal Display (LCD) Driver .....	349
Section 18. Input/Output (I/O) Ports .....	375
Section 19. External Interrupt (IRQ) .....	401

**Section 20. Keyboard Interrupt Module (KBI) . . . . .407**  
**Section 21. Computer Operating Properly (COP) . . . .415**  
**Section 22. Low-Voltage Inhibit (LVI) . . . . .421**  
**Section 23. Break Module (BRK) . . . . .427**  
**Section 24. Electrical Specifications . . . . .435**  
**Section 25. Mechanical Specifications . . . . .451**  
**Section 26. Ordering Information . . . . .457**  
**Appendix A. MC68HC908LK24 . . . . .459**

## Table of Contents

### Section 1. General Description

1.1	Contents . . . . .	37
1.2	Introduction . . . . .	38
1.3	Features . . . . .	38
1.4	MCU Block Diagram . . . . .	40
1.5	Pin Assignments . . . . .	42
1.6	Pin Functions . . . . .	44
1.6.1	Power Supply Pins ( $V_{DD}$ and $V_{SS}$ ) . . . . .	44
1.6.2	Analog Power Supply Pin ( $V_{DDA}$ ) . . . . .	44
1.6.3	LCD Bias Voltage ( $V_{LCD}$ ) . . . . .	45
1.6.4	Oscillator Pins (OSC1 and OSC2) . . . . .	45
1.6.5	External Reset Pin ( $\overline{RST}$ ) . . . . .	45
1.6.6	External Interrupt Pin ( $\overline{IRQ}$ ) . . . . .	45
1.6.7	External Filter Capacitor Pin (CGMXFC) . . . . .	45
1.6.8	ADC Voltage High Reference Pin ( $V_{REFH}$ ) . . . . .	45
1.6.9	ADC Voltage Low Reference Pin ( $V_{REFL}$ ) . . . . .	46
1.6.10	Port A Input/Output (I/O) Pins (PTA7–PTA0) . . . . .	46
1.6.11	Port B I/O Pins (PTB7–PTB0) . . . . .	46
1.6.12	Port C I/O Pins (PTC7–PTC0) . . . . .	46
1.6.13	Port D I/O Pins (PTD7–PTD0) . . . . .	46
1.6.14	Port E I/O Pins (PTE7–PTE0) . . . . .	47
1.6.15	Port F I/O Pins (PTF7–PTF0) . . . . .	47
1.6.16	LCD Backplane and Frontplane (BP0–BP2, BP3/FP0, FP1–FP10, FP27–FP32) . . . . .	47

**Section 2. Memory Map**

2.1 Contents .....49

2.2 Introduction .....49

2.3 Unimplemented Memory Locations .....49

2.4 Reserved Memory Locations .....50

2.5 Input/Output (I/O) Section .....50

**Section 3. Random-Access Memory (RAM)**

3.1 Contents .....67

3.2 Introduction .....67

3.3 Functional Description .....67

**Section 4. FLASH Memory (FLASH)**

4.1 Contents .....69

4.2 Introduction .....69

4.3 Functional Description .....70

4.4 FLASH Control Register .....71

4.5 FLASH Page Erase Operation .....72

4.6 FLASH Mass Erase Operation .....73

4.7 FLASH Program Operation .....74

4.8 FLASH Block Protection .....76

4.8.1 FLASH Block Protect Register .....77

**Section 5. Configuration Registers (CONFIG)**

5.1 Contents .....79

5.2 Introduction .....79

5.3 Functional Description .....80

5.4 Configuration Register 1 (CONFIG1) .....81

5.5 Configuration Register 2 (CONFIG2) .....82



**Section 6. Central Processor Unit (CPU)**

6.1 Contents . . . . .85

6.2 Introduction . . . . .86

6.3 Features . . . . .86

6.4 CPU Registers . . . . .87

6.4.1 Accumulator . . . . .87

6.4.2 Index Register . . . . .88

6.4.3 Stack Pointer . . . . .88

6.4.4 Program Counter . . . . .89

6.4.5 Condition Code Register . . . . .90

6.5 Arithmetic/Logic Unit (ALU) . . . . .92

6.6 Low-Power Modes . . . . .92

6.6.1 Wait Mode . . . . .92

6.6.2 Stop Mode . . . . .93

6.7 CPU During Break Interrupts . . . . .93

6.8 Instruction Set Summary . . . . .93

6.9 Opcode Map . . . . .93

**Section 7. Oscillator (OSC)**

7.1 Contents . . . . .103

7.2 Introduction . . . . .103

7.3 Internal Oscillator . . . . .105

7.4 X-tal Oscillator . . . . .105

7.5 I/O Signals . . . . .105

7.5.1 Crystal Amplifier Input Pin (OSC1) . . . . .106

7.5.2 Crystal Amplifier Output Pin (OSC2) . . . . .106

7.5.3 Oscillator Enable Signal (SIMOSCEN) . . . . .106

7.5.4 Internal RC Clock (ICLK) . . . . .106

7.5.5 CGM Oscillator Clock (CGMXCLK) . . . . .106

7.5.6 CGM Reference Clock (CGMRCLK) . . . . .106

7.6 Low Power Modes .....106  
 7.6.1 Wait Mode .....107  
 7.6.2 Stop Mode .....107  
 7.7 Oscillator During Break Mode.....107

**Section 8. Clock Generator Module (CGM)**

8.1 Contents .....109  
 8.2 Introduction.....110  
 8.3 Features .....111  
 8.4 Functional Description .....111  
 8.4.1 Oscillator Module .....114  
 8.4.2 Phase-Locked Loop Circuit (PLL) .....114  
 8.4.3 PLL Circuits .....114  
 8.4.4 Acquisition and Tracking Modes .....116  
 8.4.5 Manual and Automatic PLL Bandwidth Modes.....116  
 8.4.6 Programming the PLL .....118  
 8.4.7 Special Programming Exceptions .....122  
 8.4.8 Base Clock Selector Circuit .....122  
 8.4.9 CGM External Connections .....123  
 8.5 I/O Signals .....123  
 8.5.1 External Filter Capacitor Pin (CGMXFC) .....124  
 8.5.2 PLL Analog Power Pin ( $V_{DDA}$ ) .....124  
 8.5.3 PLL Analog Ground Pin ( $V_{SSA}$ ) .....124  
 8.5.4 Oscillator Output Frequency Signal (CGMXCLK) .....124  
 8.5.5 CGM Reference Clock (CGMRCLK) .....124  
 8.5.6 CGM VCO Clock Output (CGMVCLK).....125  
 8.5.7 CGM Base Clock Output (CGMOUT).....125  
 8.5.8 CGM CPU Interrupt (CGMINT) .....125  
 8.6 CGM Registers.....125  
 8.6.1 PLL Control Register .....126  
 8.6.2 PLL Bandwidth Control Register .....128  
 8.6.3 PLL Multiplier Select Registers .....130  
 8.6.4 PLL VCO Range Select Register .....131  
 8.6.5 PLL Reference Divider Select Register .....132

8.7 Interrupts . . . . . 133

8.8 Special Modes . . . . . 133

8.8.1 Wait Mode . . . . . 133

8.8.2 Stop Mode . . . . . 134

8.8.3 CGM During Break Interrupts . . . . . 134

8.9 Acquisition/Lock Time Specifications . . . . . 135

8.9.1 Acquisition/Lock Time Definitions . . . . . 135

8.9.2 Parametric Influences on Reaction Time . . . . . 135

8.9.3 Choosing a Filter . . . . . 137

**Section 9. System Integration Module (SIM)**

9.1 Contents . . . . . 139

9.2 Introduction . . . . . 140

9.3 SIM Bus Clock Control and Generation . . . . . 142

9.3.1 Bus Timing . . . . . 143

9.3.2 Clock Start-up from POR or LVI Reset . . . . . 143

9.3.3 Clocks in Stop Mode and Wait Mode . . . . . 144

9.4 Reset and System Initialization . . . . . 144

9.4.1 External Pin Reset . . . . . 145

9.4.2 Active Resets from Internal Sources . . . . . 145

9.4.2.1 Power-On Reset . . . . . 146

9.4.2.2 Computer Operating Properly (COP) Reset . . . . . 147

9.4.2.3 Illegal Opcode Reset . . . . . 148

9.4.2.4 Illegal Address Reset . . . . . 148

9.4.2.5 Low-Voltage Inhibit (LVI) Reset . . . . . 148

9.4.2.6 Monitor Mode Entry Module Reset (MODRST) . . . . . 148

9.5 SIM Counter . . . . . 149

9.5.1 SIM Counter During Power-On Reset . . . . . 149

9.5.2 SIM Counter During Stop Mode Recovery . . . . . 149

9.5.3 SIM Counter and Reset States . . . . . 149

9.6 Exception Control . . . . . 150

9.6.1 Interrupts . . . . . 150

9.6.1.1 Hardware Interrupts . . . . . 152

9.6.1.2 SWI Instruction . . . . . 153

9.6.1.3 Interrupt Status Registers .....153

9.6.1.4 Interrupt Status Register 1 .....153

9.6.1.5 Interrupt Status Register 2 .....155

9.6.1.6 Interrupt Status Register 3 .....155

9.6.2 Reset .....156

9.6.3 Break Interrupts .....156

9.6.4 Status Flag Protection in Break Mode .....156

9.7 Low-Power Modes .....157

9.7.1 Wait Mode .....157

9.7.2 Stop Mode .....158

9.8 SIM Registers .....159

9.8.1 SIM Break Status Register .....160

9.8.2 SIM Reset Status Register .....161

9.8.3 SIM Break Flag Control Register .....162

**Section 10. Monitor ROM (MON)**

10.1 Contents .....163

10.2 Introduction .....164

10.3 Features .....164

10.4 Functional Description .....165

10.4.1 Entering Monitor Mode .....167

10.4.2 Data Format .....171

10.4.3 Break Signal .....171

10.4.4 Baud Rate .....171

10.4.5 Commands .....172

10.5 Security .....177

10.6 ROM-Resident Routines .....179

10.6.1 PRGRNGE .....181

10.6.2 ERARNGE .....183

10.6.3 LDRNGE .....184

10.6.4 MON\_PRGRNGE .....185

10.6.5 MON\_ERARNGE .....186

10.6.6 MON\_LDRNGE .....187

10.6.7 EE\_WRITE .....188

10.6.8 EE\_READ .....191

**Section 11. Timer Interface Module (TIM)**

11.1 Contents . . . . .193

11.2 Introduction . . . . .194

11.3 Features . . . . .194

11.4 Pin Name Conventions . . . . .195

11.5 Functional Description . . . . .195

11.5.1 TIM Counter Prescaler . . . . .199

11.5.2 Input Capture . . . . .199

11.5.3 Output Compare . . . . .200

11.5.3.1 Unbuffered Output Compare . . . . .200

11.5.3.2 Buffered Output Compare . . . . .201

11.5.4 Pulse Width Modulation (PWM) . . . . .201

11.5.4.1 Unbuffered PWM Signal Generation . . . . .202

11.5.4.2 Buffered PWM Signal Generation . . . . .203

11.5.4.3 PWM Initialization . . . . .204

11.6 Interrupts . . . . .205

11.7 Low-Power Modes . . . . .205

11.7.1 Wait Mode . . . . .206

11.7.2 Stop Mode . . . . .206

11.8 TIM During Break Interrupts . . . . .206

11.9 I/O Signals . . . . .207

11.9.1 TIM Clock Pins (PTD4/KBI4/T1CLK, PTD5/KBI5/T2CLK) .207

11.9.2 TIM Channel I/O Pins (PTB2/T1CH0, PTB3/T1CH1,  
PTB4/T2CH0, PTB5/T2CH1) . . . . .207

11.10 I/O Registers . . . . .208

11.10.1 TIM Status and Control Register . . . . .208

11.10.2 TIM Counter Registers . . . . .210

11.10.3 TIM Counter Modulo Registers . . . . .211

11.10.4 TIM Channel Status and Control Registers . . . . .212

11.10.5 TIM Channel Registers . . . . .215

## Section 12. Real Time Clock (RTC)

12.1	Contents	217
12.2	Introduction	218
12.3	Features	218
12.4	I/O Pins	219
12.5	Functional Description	221
12.5.1	Time Functions	223
12.5.2	Calendar Functions	223
12.5.3	Alarm Functions	223
12.5.4	Chronograph Functions	223
12.5.5	Timebase Interrupts	224
12.6	RTC Interrupts	224
12.7	RTC Clock Calibration and Compensation	225
12.7.1	Calibration Error	226
12.8	RTC Register and Bit Write Protection	227
12.9	Low-Power Modes	229
12.9.1	Wait Mode	229
12.9.2	Stop Mode	230
12.10	RTC Registers	230
12.10.1	RTC Calibration Control Register (RTCCOMR)	231
12.10.2	RTC Calibration Data Register (RTCCDAT)	233
12.10.3	RTC Control Register 1 (RTCCR1)	234
12.10.4	RTC Control Register 2 (RTCCR2)	235
12.10.5	RTC Status Register (RTCSR)	237
12.10.6	Alarm Minute and Hour Registers (ALMR and ALHR)	240
12.10.7	Second Register (SECR)	241
12.10.8	Minute Register (MINR)	241
12.10.9	Hour Register (HRR)	242
12.10.10	Day Register (DAYR)	242
12.10.11	Month Register (MTHR)	243
12.10.12	Year Register (YRR)	243
12.10.13	Day-Of-Week Register (DOWR)	244
12.10.14	Chronograph Data Register (CHRR)	244

## Section 13. Infrared Serial Communications Interface Module (IRSCI)

13.1	Contents	245
13.2	Introduction	246
13.3	Features	247
13.4	Pin Name Conventions	249
13.5	IRSCI Module Overview	249
13.6	Infrared Functional Description	250
13.6.1	Infrared Transmit Encoder	251
13.6.2	Infrared Receive Decoder	251
13.7	SCI Functional Description	252
13.7.1	Data Format	253
13.7.2	Transmitter	254
13.7.2.1	Character Length	255
13.7.2.2	Character Transmission	255
13.7.2.3	Break Characters	256
13.7.2.4	Idle Characters	256
13.7.2.5	Transmitter Interrupts	257
13.7.3	Receiver	257
13.7.3.1	Character Length	257
13.7.3.2	Character Reception	259
13.7.3.3	Data Sampling	259
13.7.3.4	Framing Errors	261
13.7.3.5	Baud Rate Tolerance	261
13.7.3.6	Receiver Wakeup	264
13.7.3.7	Receiver Interrupts	265
13.7.3.8	Error Interrupts	265
13.8	Low-Power Modes	266
13.8.1	Wait Mode	266
13.8.2	Stop Mode	266
13.9	SCI During Break Module Interrupts	267
13.10	I/O Signals	267
13.10.1	PTB0/TxD (Transmit Data)	267

13.10.2 PTB1/RxD (Receive Data) .....267

13.11 I/O Registers .....268

13.11.1 SCI Control Register 1 .....269

13.11.2 SCI Control Register 2 .....271

13.11.3 SCI Control Register 3 .....274

13.11.4 SCI Status Register 1 .....276

13.11.5 SCI Status Register 2 (SCS2) .....280

13.11.6 SCI Data Register .....281

13.11.7 SCI Baud Rate Register .....282

13.11.8 SCI Infrared Control Register .....285

**Section 14. Serial Peripheral Interface Module (SPI)**

14.1 Contents .....287

14.2 Introduction .....288

14.3 Features .....288

14.4 Pin Name Conventions and I/O Register Addresses .....289

14.5 Functional Description .....290

14.5.1 Master Mode .....291

14.5.2 Slave Mode .....292

14.6 Transmission Formats .....293

14.6.1 Clock Phase and Polarity Controls .....293

14.6.2 Transmission Format When CPHA = 0 .....294

14.6.3 Transmission Format When CPHA = 1 .....296

14.6.4 Transmission Initiation Latency .....297

14.7 Queuing Transmission Data .....299

14.8 Error Conditions .....300

14.8.1 Overflow Error .....300

14.8.2 Mode Fault Error .....302

14.9 Interrupts .....304

14.10 Resetting the SPI .....306

14.11 Low-Power Modes .....307

14.11.1 Wait Mode .....307



14.11.2 Stop Mode .....307

14.12 SPI During Break Interrupts .....308

14.13 I/O Signals .....308

14.13.1 MISO (Master In/Slave Out).....309

14.13.2 MOSI (Master Out/Slave In).....309

14.13.3 SPCK (Serial Clock).....310

14.13.4  $\overline{SS}$  (Slave Select) .....310

14.13.5 CGND (Clock Ground) .....311

14.14 I/O Registers.....312

14.14.1 SPI Control Register.....312

14.14.2 SPI Status and Control Register .....314

14.14.3 SPI Data Register.....317

**Section 15. Multi-Master IIC Interface (MMIIC)**

15.1 Contents .....319

15.2 Introduction.....319

15.3 Features .....320

15.4 I/O Pins.....320

15.5 Multi-Master IIC Registers .....321

15.5.1 Multi-Master IIC Address Register (MMADR) .....321

15.5.2 Multi-Master IIC Control Register (MMCR) .....323

15.5.3 Multi-Master IIC Master Control Register (MIMCR) .....324

15.5.4 Multi-Master IIC Status Register (MMSR) .....326

15.5.5 Multi-Master IIC Data Transmit Register (MMDTR) .....328

15.5.6 Multi-Master IIC Data Receive Register (MMDRR) .....329

15.6 Programming Considerations.....330

**Section 16. Analog-to-Digital Converter (ADC)**

16.1 Contents .....333

16.2 Introduction.....334

16.3 Features .....334

16.4 Functional Descriptions .....335

16.4.1 ADC Port I/O Pins .....335

16.4.2 Voltage Conversion .....337

16.4.3 Conversion Time .....337

16.4.4 Continuous Conversion .....338

16.4.5 Result Justification .....338

16.4.6 Monotonicity .....339

16.5 Interrupts .....340

16.6 Low-Power Modes .....340

16.6.1 Wait Mode .....340

16.6.2 Stop Mode .....340

16.7 I/O Signals .....340

16.7.1 ADC Voltage In ( $V_{ADIN}$ ) .....341

16.7.2 ADC Analog Power Pin ( $V_{DDA}$ ) .....341

16.7.3 ADC Analog Ground Pin ( $V_{SSA}$ ) .....341

16.7.4 ADC Voltage Reference High Pin ( $V_{REFH}$ ) .....341

16.7.5 ADC Voltage Reference Low Pin ( $V_{REFL}$ ) .....341

16.8 I/O Registers .....342

16.8.1 ADC Status and Control Register .....342

16.8.2 ADC Data Register .....344

16.8.3 ADC Clock Control Register .....346

**Section 17. Liquid Crystal Display (LCD) Driver**

17.1 Contents .....349

17.2 Introduction .....350

17.3 Features .....350

17.4 Pin Name Conventions and I/O Register Addresses .....350

17.5 Functional Description .....353

17.5.1 LCD Duty .....355

17.5.2 LCD Voltages ( $V_{LCD}$ ,  $V_{LCD1}$ ,  $V_{LCD2}$ ,  $V_{LCD3}$ ) .....355

17.5.3 LCD Cycle Frame .....355

17.5.4 Fast Charge and Low Current .....356

17.5.5 Contrast Control .....357

17.6 Low-Power Modes .....357

17.6.1 Wait Mode .....358

17.6.2 Stop Mode .....358

17.7 I/O Signals .....358

17.7.1 BP0–BP3 (Backplane Drivers) .....359

17.7.2 FP0–FP32 (Frontplane Drivers) .....361

17.8 Seven Segment Display Connection .....365

17.9 I/O Registers .....368

17.9.1 LCD Control Register (LCDCR) .....368

17.9.2 LCD Clock Register (LCDCLK) .....370

17.9.3 LCD Data Registers (LDAT1–LDAT17) .....372

**Section 18. Input/Output (I/O) Ports**

18.1 Contents .....375

18.2 Introduction .....376

18.3 Port A .....380

18.3.1 Port A Data Register (PTA) .....380

18.3.2 Data Direction Register A (DDRA) .....381

18.4 Port B .....383

18.4.1 Port B Data Register (PTB) .....383

18.4.2 Data Direction Register B (DDRB) .....385

18.4.3 Port B LED Control Register (LEDB) .....386

18.5 Port C .....387

18.5.1 Port C Data Register (PTC) .....387

18.5.2 Data Direction Register C (DDRC) .....388

18.5.3 Port C LED Control Register (LEDC) .....389

18.6 Port D .....390

18.6.1 Port D Data Register (PTD) .....390

18.6.2 Data Direction Register D (DDRD) .....392

18.7 Port E .....394

18.7.1 Port E Data Register (PTE) .....394

18.7.2 Data Direction Register E (DDRE) .....395

18.7.3 Port E LED Control Register (LEDE) .....396

18.8 Port F .....397  
 18.8.1 Port F Data Register (PTF) .....397  
 18.8.2 Data Direction Register F (DDRF) .....398  
 18.8.3 Port F LED Control Register (LEDF) .....399

**Section 19. External Interrupt (IRQ)**

19.1 Contents .....401  
 19.2 Introduction .....401  
 19.3 Features .....401  
 19.4 Functional Description .....402  
 19.4.1  $\overline{\text{IRQ}}$  Pin .....404  
 19.5 IRQ Module During Break Interrupts .....405  
 19.6 IRQ Status and Control Register (INTSCR) .....405

**Section 20. Keyboard Interrupt Module (KBI)**

20.1 Contents .....407  
 20.2 Introduction .....407  
 20.3 Features .....408  
 20.4 I/O Pins .....408  
 20.5 Functional Description .....409  
 20.5.1 Keyboard Initialization .....411  
 20.6 Keyboard Interrupt Registers .....412  
 20.6.1 Keyboard Status and Control Register .....412  
 20.6.2 Keyboard Interrupt Enable Register .....413  
 20.7 Low-Power Modes .....414  
 20.7.1 Wait Mode .....414  
 20.7.2 Stop Mode .....414  
 20.8 Keyboard Module During Break Interrupts .....414

**Section 21. Computer Operating Properly (COP)**

21.1 Contents . . . . . 415

21.2 Introduction . . . . . 415

21.3 Functional Description . . . . . 416

21.4 I/O Signals . . . . . 417

21.4.1 ICLK . . . . . 417

21.4.2 STOP Instruction . . . . . 417

21.4.3 COPCTL Write . . . . . 417

21.4.4 Power-On Reset . . . . . 417

21.4.5 Internal Reset . . . . . 418

21.4.6 Reset Vector Fetch . . . . . 418

21.4.7 COPD (COP Disable) . . . . . 418

21.4.8 COPRS (COP Rate Select) . . . . . 418

21.5 COP Control Register . . . . . 419

21.6 Interrupts . . . . . 419

21.7 Monitor Mode . . . . . 419

21.8 Low-Power Modes . . . . . 419

21.8.1 Wait Mode . . . . . 420

21.8.2 Stop Mode . . . . . 420

21.9 COP Module During Break Mode . . . . . 420

**Section 22. Low-Voltage Inhibit (LVI)**

22.1 Contents . . . . . 421

22.2 Introduction . . . . . 421

22.3 Features . . . . . 421

22.4 Functional Description . . . . . 422

22.4.1 Polled LVI Operation . . . . . 424

22.4.2 Forced Reset Operation . . . . . 424

22.4.3 Voltage Hysteresis Protection . . . . . 424

22.4.4 LVI Trip Selection . . . . . 425

22.5 LVI Status Register . . . . . 425

22.6 Low-Power Modes .....426  
 22.6.1 Wait Mode .....426  
 22.6.2 Stop Mode .....426

**Section 23. Break Module (BRK)**

23.1 Contents .....427  
 23.2 Introduction .....427  
 23.3 Features .....428  
 23.4 Functional Description .....428  
 23.4.1 Flag Protection During Break Interrupts .....430  
 23.4.2 CPU During Break Interrupts .....430  
 23.4.3 TIM1 and TIM2 During Break Interrupts .....430  
 23.4.4 COP During Break Interrupts .....430  
 23.5 Low-Power Modes .....430  
 23.5.1 Wait Mode .....430  
 23.5.2 Stop Mode .....431  
 23.6 Break Module Registers .....431  
 23.6.1 Break Status and Control Register .....431  
 23.6.2 Break Address Registers .....432  
 23.6.3 SIM Break Status Register .....432  
 23.6.4 SIM Break Flag Control Register .....434

**Section 24. Electrical Specifications**

24.1 Contents .....435  
 24.2 Introduction .....435  
 24.3 Absolute Maximum Ratings .....436  
 24.4 Functional Operating Range .....437  
 24.5 Thermal Characteristics .....437  
 24.6 5V DC Electrical Characteristics .....438  
 24.7 3.3V DC Electrical Characteristics .....439  
 24.8 5V Control Timing .....440

24.9 3.3V Control Timing .....441

24.10 5V Oscillator Characteristics .....441

24.11 3.3V Oscillator Characteristics .....442

24.12 5V ADC Electrical Characteristics .....443

24.13 3.3V ADC Electrical Characteristics .....444

24.14 Timer Interface Module Characteristics .....445

24.15 CGM Electrical Specifications .....445

24.16 5V SPI Characteristics .....446

24.17 3.3V SPI Characteristics .....447

24.18 FLASH Memory Characteristics .....450

**Section 25. Mechanical Specifications**

25.1 Contents .....451

25.2 Introduction .....451

25.3 64-Pin Low-Profile Quad Flat Pack (LQFP) .....452

25.4 64-Pin Quad Flat Pack (QFP) .....453

25.5 80-Pin Low-Profile Quad Flat Pack (LQFP) .....454

25.6 80-Pin Quad Flat Pack (QFP) .....455

**Section 26. Ordering Information**

26.1 Contents .....457

26.2 Introduction .....457

26.3 MC Order Numbers .....457

**Appendix A. MC68HC908LK24**

A.1 Contents .....459

A.2 Introduction .....459

A.3 Oscillator . . . . .460

A.4 Low-Voltage Inhibit . . . . .460

A.5 Electrical Specifications . . . . .461

A.5.1 5V DC Electrical Characteristics . . . . .461

A.5.2 3.3V DC Electrical Characteristics . . . . .461

A.5.3 5V Oscillator Characteristics . . . . .462

A.5.4 3.3V Oscillator Characteristics . . . . .462

A.6 MC Order Numbers . . . . .462



## List of Figures

Figure	Title	Page
1-1	MC68HC908LJ24 Block Diagram . . . . .	41
1-2	80-Pin QFP and LQFP Pin Assignment . . . . .	42
1-3	64-pin QFP and LQFP Pin Assignment . . . . .	43
1-4	Power Supply Bypassing . . . . .	44
2-1	Memory Map . . . . .	51
2-2	Control, Status, and Data Registers . . . . .	52
4-1	FLASH I/O Register Summary . . . . .	70
4-2	FLASH Control Register (FLCR) . . . . .	71
4-3	FLASH Programming Flowchart . . . . .	75
4-4	FLASH Block Protect Register (FLBPR) . . . . .	77
5-1	CONFIG Registers Summary . . . . .	80
5-2	Configuration Register 1 (CONFIG1) . . . . .	81
5-3	Configuration Register 2 (CONFIG2) . . . . .	82
6-1	CPU Registers . . . . .	87
6-2	Accumulator (A) . . . . .	87
6-3	Index Register (H:X) . . . . .	88
6-4	Stack Pointer (SP) . . . . .	88
6-5	Program Counter (PC) . . . . .	89
6-6	Condition Code Register (CCR) . . . . .	90
7-1	Oscillator Module Block Diagram . . . . .	104
8-1	CGM Block Diagram . . . . .	112
8-2	CGM I/O Register Summary . . . . .	113
8-3	CGM External Connections . . . . .	123
8-4	PLL Control Register (PCTL) . . . . .	126

Figure	Title	Page
8-5	PLL Bandwidth Control Register (PBWCR) . . . . .	129
8-6	PLL Multiplier Select Register High (PMSH) . . . . .	130
8-7	PLL Multiplier Select Register Low (PMSL) . . . . .	130
8-8	PLL VCO Range Select Register (PMRS) . . . . .	131
8-9	PLL Reference Divider Select Register (PMDS) . . . . .	132
8-10	PLL Filter . . . . .	137
9-1	SIM Block Diagram . . . . .	141
9-2	SIM I/O Register Summary . . . . .	142
9-3	CGM Clock Signals . . . . .	143
9-4	External Reset Timing . . . . .	145
9-5	Internal Reset Timing . . . . .	146
9-6	Sources of Internal Reset . . . . .	146
9-7	POR Recovery . . . . .	147
9-8	Interrupt Entry Timing . . . . .	150
9-9	Interrupt Recovery Timing . . . . .	150
9-10	Interrupt Processing . . . . .	151
9-11	Interrupt Recognition Example . . . . .	152
9-12	Interrupt Status Register 1 (INT1) . . . . .	153
9-13	Interrupt Status Register 2 (INT2) . . . . .	155
9-14	Interrupt Status Register 3 (INT3) . . . . .	155
9-15	Wait Mode Entry Timing . . . . .	157
9-16	Wait Recovery from Interrupt or Break . . . . .	158
9-17	Wait Recovery from Internal Reset . . . . .	158
9-18	Stop Mode Entry Timing . . . . .	159
9-19	Stop Mode Recovery from Interrupt or Break . . . . .	159
9-20	SIM Break Status Register (SBSR) . . . . .	160
9-21	SIM Reset Status Register (SRSR) . . . . .	161
9-22	SIM Break Flag Control Register (SBFCR) . . . . .	162
10-1	Monitor Mode Circuit . . . . .	166
10-2	Low-Voltage Monitor Mode Entry Flowchart . . . . .	170
10-3	Monitor Data Format . . . . .	171
10-4	Break Transaction . . . . .	171
10-5	Read Transaction . . . . .	173
10-6	Write Transaction . . . . .	173

Figure	Title	Page
10-7	Stack Pointer at Monitor Mode Entry .....	176
10-8	Monitor Mode Entry Timing .....	177
10-9	Data Block Format for ROM-Resident Routines .....	180
10-10	EE_WRITE FLASH Memory Usage .....	189
11-1	TIM Block Diagram .....	196
11-2	TIM I/O Register Summary .....	197
11-3	PWM Period and Pulse Width .....	202
11-4	TIM Status and Control Register (TSC) .....	208
11-5	TIM Counter Registers High (TCNTH) .....	210
11-6	TIM Counter Registers Low (TCNTL) .....	211
11-7	TIM Counter Modulo Register High (TMODH) .....	211
11-8	TIM Counter Modulo Register Low (TMODL) .....	211
11-9	TIM Channel 0 Status and Control Register (TSC0) .....	212
11-10	TIM Channel 1 Status and Control Register (TSC1) .....	212
11-11	CHxMAX Latency .....	215
11-12	TIM Channel 0 Register High (TCH0H) .....	216
11-13	TIM Channel 0 Register Low (TCH0L) .....	216
11-14	TIM Channel 1 Register High (TCH1H) .....	216
11-15	TIM Channel 1 Register Low (TCH1L) .....	216
12-1	RTC I/O Register Summary .....	219
12-2	RTC Block Diagram .....	222
12-3	RTC Clock Calibration and Compensation .....	225
12-4	1-Hz Clock Compensation .....	227
12-5	RTC Write Protect State Diagram .....	228
12-6	RTC Calibration Control Register (RTCCOMR) .....	231
12-7	RTC Calibration Data Register (RTCCDAT) .....	233
12-8	RTC Control Register 1 (RTCCR1) .....	234
12-9	RTC Control Register 2 (RTCCR2) .....	235
12-10	RTC Status Register (RTCSR) .....	237
12-11	Alarm Minute Register (ALMR) .....	240
12-12	Alarm Hour Register (ALHR) .....	240
12-13	Second Register (SECR) .....	241
12-14	Minute Register (MINR) .....	241
12-15	Hour Register (HRR) .....	242

Figure	Title	Page
12-16	Day Register (DAYR) . . . . .	242
12-17	Month Register (MTHR) . . . . .	243
12-18	Year Register (YRR) . . . . .	243
12-19	Day-Of-Week Register (DOWR) . . . . .	244
12-20	Chronograph Data Register (CHRR) . . . . .	244
13-1	IRSCI I/O Registers Summary . . . . .	248
13-2	IRSCI Block Diagram . . . . .	249
13-3	Infrared Sub-Module Diagram . . . . .	250
13-4	Infrared SCI Data Example . . . . .	251
13-5	SCI Module Block Diagram . . . . .	252
13-6	SCI Data Formats . . . . .	253
13-7	SCI Transmitter . . . . .	254
13-8	SCI Receiver Block Diagram . . . . .	258
13-9	Receiver Data Sampling . . . . .	259
13-10	Slow Data . . . . .	262
13-11	Fast Data . . . . .	263
13-12	SCI Control Register 1 (SCC1) . . . . .	269
13-13	SCI Control Register 2 (SCC2) . . . . .	272
13-14	SCI Control Register 3 (SCC3) . . . . .	274
13-15	SCI Status Register 1 (SCS1) . . . . .	276
13-16	Flag Clearing Sequence . . . . .	279
13-17	SCI Status Register 2 (SCS2) . . . . .	280
13-18	SCI Data Register (SCDR) . . . . .	281
13-19	SCI Baud Rate Register (SCBR) . . . . .	282
13-20	SCI Infrared Control Register (SCIRCR) . . . . .	285
14-1	SPI I/O Register Summary . . . . .	289
14-2	SPI Module Block Diagram . . . . .	290
14-3	Full-Duplex Master-Slave Connections . . . . .	291
14-4	Transmission Format (CPHA = 0) . . . . .	295
14-5	CPHA/SS Timing . . . . .	295
14-6	Transmission Format (CPHA = 1) . . . . .	296
14-7	Transmission Start Delay (Master) . . . . .	298
14-8	SPRF/SPTE CPU Interrupt Timing . . . . .	299
14-9	Missed Read of Overflow Condition . . . . .	301

Figure	Title	Page
14-10	Clearing SPRF When OVRF Interrupt Is Not Enabled . . . . .	302
14-11	SPI Interrupt Request Generation . . . . .	305
14-12	CPHA/SS Timing . . . . .	310
14-13	SPI Control Register (SPCR) . . . . .	312
14-14	SPI Status and Control Register (SPSCR) . . . . .	314
14-15	SPI Data Register (SPDR) . . . . .	317
15-1	MMIIC I/O Register Summary . . . . .	321
15-2	Multi-Master IIC Address Register (MMADR) . . . . .	321
15-3	Multi-Master IIC Control Register (MMCR) . . . . .	323
15-4	Multi-Master IIC Master Control Register (MIMCR) . . . . .	324
15-5	Multi-Master IIC Status Register (MMSR) . . . . .	326
15-6	Multi-Master IIC Data Transmit Register (MMDTR) . . . . .	328
15-7	Multi-Master IIC Data Receive Register (MMDRR) . . . . .	329
15-8	Data Transfer Sequences for Master/Slave Transmit/Receive Modes . . . . .	331
16-1	ADC I/O Register Summary . . . . .	335
16-2	ADC Block Diagram . . . . .	336
16-3	8-Bit Truncation Mode Error . . . . .	339
16-4	ADC Status and Control Register (ADSCR) . . . . .	342
16-5	ADRH and ADRL in 8-Bit Truncated Mode . . . . .	344
16-6	ADRH and ADRL in Right Justified Mode . . . . .	344
16-7	ADRH and ADRL in Left Justified Mode . . . . .	345
16-8	ADRH and ADRL in Left Justified Sign Data Mode . . . . .	345
16-9	ADC Clock Control Register (ADCLK) . . . . .	346
17-1	LCD I/O Register Summary . . . . .	351
17-2	LCD Block Diagram . . . . .	353
17-3	Simplified LCD Schematic (1/3 Duty, 1/3 Bias) . . . . .	354
17-4	Fast Charge Timing . . . . .	357
17-5	Static LCD Backplane Driver Waveform . . . . .	359
17-6	1/3 Duty LCD Backplane Driver Waveforms . . . . .	359
17-7	1/4 Duty LCD Backplane Driver Waveforms . . . . .	360
17-8	Static LCD Frontplane Driver Waveforms . . . . .	361
17-9	1/3 Duty LCD Frontplane Driver Waveforms . . . . .	362
17-10	1/4 Duty LCD Frontplane Driver Waveforms . . . . .	363

Figure	Title	Page
17-11	1/4 Duty LCD Frontplane Driver Waveforms (continued) . . . .	364
17-12	7-Segment Display Example . . . . .	365
17-13	BP0–BP2 and FP0–FP2 Output Waveforms for 7-Segment Display Example . . . . .	366
17-14	"f" Segment Voltage Waveform . . . . .	367
17-15	"e" Segment Voltage Waveform . . . . .	367
17-16	LCD Control Register (LCDCR) . . . . .	368
17-17	LCD Clock Register (LCDCLK) . . . . .	370
17-18	LCD Data Registers 1–17 (LDAT1–LDAT17) . . . . .	372
18-1	I/O Port Register Summary . . . . .	376
18-2	Port A Data Register (PTA) . . . . .	380
18-3	Data Direction Register A (DDRA) . . . . .	381
18-4	Port A I/O Circuit . . . . .	382
18-5	Port B Data Register (PTB) . . . . .	383
18-6	Data Direction Register B (DDRB) . . . . .	385
18-7	Port B I/O Circuit . . . . .	385
18-8	Port B LED Control Register (LEDB) . . . . .	386
18-9	Port C Data Register (PTC) . . . . .	387
18-10	Data Direction Register C (DDRC) . . . . .	388
18-11	Port C I/O Circuit . . . . .	388
18-12	Port C LED Control Register (LEDC) . . . . .	389
18-13	Port D Data Register (PTD) . . . . .	390
18-14	Data Direction Register D (DDRD) . . . . .	392
18-15	Port D I/O Circuit . . . . .	392
18-16	Port E Data Register (PTE) . . . . .	394
18-17	Data Direction Register E (DDRE) . . . . .	395
18-18	Port E I/O Circuit . . . . .	395
18-19	Port E LED Control Register (LEDE) . . . . .	396
18-20	Port F Data Register (PTF) . . . . .	397
18-21	Data Direction Register F (DDRF) . . . . .	398
18-22	Port F I/O Circuit . . . . .	398
18-23	Port F LED Control Register (LEDF) . . . . .	399
19-1	IRQ Module Block Diagram . . . . .	403
19-2	IRQ I/O Port Register Summary . . . . .	403

Figure	Title	Page
19-3	IRQ Status and Control Register (INTSCR) . . . . .	406
20-1	KBI I/O Register Summary . . . . .	408
20-2	Keyboard Interrupt Block Diagram . . . . .	409
20-3	Keyboard Status and Control Register (KBSCR) . . . . .	412
20-4	Keyboard Interrupt Enable Register (KBIER) . . . . .	413
21-1	COP Block Diagram . . . . .	416
21-2	Configuration Register 1 (CONFIG1) . . . . .	418
21-3	COP Control Register (COPCTL) . . . . .	419
22-1	LVI I/O Register Summary . . . . .	422
22-2	LVI Module Block Diagram . . . . .	422
23-1	Break Module Block Diagram . . . . .	429
23-2	Break Module I/O Register Summary . . . . .	429
23-3	Break Status and Control Register (BRKSCR) . . . . .	431
23-4	Break Address Register High (BRKH) . . . . .	432
23-5	Break Address Register Low (BRKL) . . . . .	432
23-6	SIM Break Status Register (SBSR) . . . . .	433
23-7	SIM Break Flag Control Register (SBFCR) . . . . .	434
24-1	Typical Internal Oscillator Frequency . . . . .	442
24-2	SPI Master Timing . . . . .	448
24-3	SPI Slave Timing . . . . .	449
25-1	64-Pin Low-Profile Quad Flat Pack (Case No. 840F) . . . . .	452
25-2	64-Pin Quad Flat Pack (Case No. 840B) . . . . .	453
25-3	80-Pin Low-Profile Quad Flat Pack (Case No. 917) . . . . .	454
25-4	80-Pin Quad Flat Pack (Case No. 841B) . . . . .	455
A-1	MC68HC908LK24 Crystal Oscillator Connection . . . . .	460
A-2	MC68HC908LK24 Configuration Register 1 (CONFIG1) . . . . .	460





## List of Tables

Table	Title	Page
2-1	Vector Addresses . . . . .	65
4-1	FLASH Block Protect Register to Physical Address . . . . .	78
5-1	LVI Trip Point Selection . . . . .	84
6-1	Instruction Set Summary . . . . .	94
6-2	Opcode Map . . . . .	102
8-1	Numeric Examples . . . . .	121
8-3	VPR1 and VPR0 Programming . . . . .	128
8-2	PRE 1 and PRE0 Programming . . . . .	128
9-1	Signal Name Conventions . . . . .	141
9-2	PIN Bit Set Timing . . . . .	145
9-3	Vector Addresses . . . . .	154
10-1	Monitor Mode Signal Requirements and Options . . . . .	168
10-2	Mode Differences (Vectors) . . . . .	170
10-3	Monitor Baud Rate Selection . . . . .	172
10-4	READ (Read Memory) Command . . . . .	173
10-5	WRITE (Write Memory) Command . . . . .	174
10-6	IREAD (Indexed Read) Command . . . . .	174
10-7	IWRITE (Indexed Write) Command . . . . .	175
10-8	READSP (Read Stack Pointer) Command . . . . .	175
10-9	RUN (Run User Program) Command . . . . .	176
10-10	Summary of ROM-Resident Routines . . . . .	179
10-11	PRGRNGE Routine . . . . .	181
10-12	ERARNGE Routine . . . . .	183
10-13	LDRNGE Routine . . . . .	184

Table	Title	Page
10-14	MON_PRGRNGE Routine . . . . .	185
10-15	MON_ERARNGE Routine . . . . .	186
10-16	ICP_LDRNGE Routine . . . . .	187
10-17	EE_WRITE Routine . . . . .	188
10-18	EE_READ Routine . . . . .	191
11-1	Pin Name Conventions . . . . .	195
11-2	Prescaler Selection . . . . .	210
11-3	Mode, Edge, and Level Selection . . . . .	214
12-1	Pin Name Conventions . . . . .	219
12-2	Compensation Algorithm for Different Values of E . . . . .	226
12-3	Write-Protected RTC Registers and Bits . . . . .	227
12-4	CALOUT Pin Output Option . . . . .	232
13-1	Pin Name Conventions . . . . .	249
13-2	Start Bit Verification . . . . .	260
13-3	Data Bit Recovery . . . . .	260
13-4	Stop Bit Recovery . . . . .	261
13-5	SCI Pin Functions (Standard and Infrared) . . . . .	268
13-6	Character Format Selection . . . . .	271
13-7	SCI Baud Rate Prescaling . . . . .	282
13-8	SCI Baud Rate Selection . . . . .	283
13-9	SCI Baud Rate Selection Examples . . . . .	284
13-10	Infrared Narrow Pulse Selection . . . . .	285
14-1	Pin Name Conventions . . . . .	289
14-2	SPI Interrupts . . . . .	304
14-3	SPI Configuration . . . . .	311
14-4	SPI Master Baud Rate Selection . . . . .	316
15-1	Pin Name Conventions . . . . .	320
15-2	Baud Rate Select . . . . .	326
16-1	MUX Channel Select . . . . .	343
16-2	ADC Clock Divide Ratio . . . . .	346
16-3	ADC Mode Select . . . . .	347

Table	Title	Page
17-1	Pin Name Conventions . . . . .	350
17-3	LCD Bias Voltage Control . . . . .	369
17-2	Resistor Ladder Selection . . . . .	369
17-4	Fast Charge Duty Cycle Selection . . . . .	370
17-5	LCD Duty Cycle Selection . . . . .	371
17-6	LCD Waveform Base Clock Selection . . . . .	371
18-1	Port Control Register Bits Summary . . . . .	378
18-2	Port A Pin Functions . . . . .	382
18-3	Port B Pin Functions . . . . .	386
18-4	Port C Pin Functions . . . . .	389
18-5	Port D Pin Functions . . . . .	393
18-6	Port E Pin Functions . . . . .	396
18-7	Port F Pin Functions . . . . .	399
20-1	Pin Name Conventions . . . . .	408
22-1	LVI Status Register (LVISR) . . . . .	425
22-2	LVIOUT Bit Indication . . . . .	425
24-1	Absolute Maximum Ratings . . . . .	436
24-2	Functional Operating Range . . . . .	437
24-3	Thermal Characteristics . . . . .	437
24-4	5V DC Electrical Characteristics . . . . .	438
24-5	3.3V DC Electrical Characteristics . . . . .	439
24-6	5V Control Timing . . . . .	440
24-7	3.3V Control Timing . . . . .	441
24-8	5V Oscillator Specifications . . . . .	441
24-9	3.3V Oscillator Specifications . . . . .	442
24-10	5V ADC Electrical Characteristics . . . . .	443
24-11	3.3V ADC Electrical Characteristics . . . . .	444
24-12	Timer Interface Module Characteristics . . . . .	445
24-13	CGM Electrical Specifications . . . . .	445
24-14	5V SPI Characteristics . . . . .	446
24-15	3.3V SPI Characteristics . . . . .	447
24-16	FLASH Memory Electrical Characteristics . . . . .	450
26-1	MC Order Numbers . . . . .	457

<b>Table</b>	<b>Title</b>	<b>Page</b>
A-1	5V DC Electrical Characteristics .....	461
A-2	3.3V DC Electrical Characteristics .....	461
A-3	5V Oscillator Specifications .....	462
A-4	3.3V Oscillator Specifications .....	462
A-5	MC68HC908LK24 Order Numbers .....	462

## Section 1. General Description

### 1.1 Contents

1.2	Introduction . . . . .	38
1.3	Features . . . . .	38
1.4	MCU Block Diagram . . . . .	40
1.5	Pin Assignments . . . . .	42
1.6	Pin Functions . . . . .	44
1.6.1	Power Supply Pins ( $V_{DD}$ and $V_{SS}$ ) . . . . .	44
1.6.2	Analog Power Supply Pin ( $V_{DDA}$ ) . . . . .	44
1.6.3	LCD Bias Voltage ( $V_{LCD}$ ) . . . . .	45
1.6.4	Oscillator Pins (OSC1 and OSC2) . . . . .	45
1.6.5	External Reset Pin ( $\overline{RST}$ ) . . . . .	45
1.6.6	External Interrupt Pin ( $\overline{IRQ}$ ) . . . . .	45
1.6.7	External Filter Capacitor Pin (CGMXFC) . . . . .	45
1.6.8	ADC Voltage High Reference Pin ( $V_{REFH}$ ) . . . . .	45
1.6.9	ADC Voltage Low Reference Pin ( $V_{REFL}$ ) . . . . .	46
1.6.10	Port A Input/Output (I/O) Pins (PTA7–PTA0) . . . . .	46
1.6.11	Port B I/O Pins (PTB7–PTB0) . . . . .	46
1.6.12	Port C I/O Pins (PTC7–PTC0) . . . . .	46
1.6.13	Port D I/O Pins (PTD7–PTD0) . . . . .	46
1.6.14	Port E I/O Pins (PTE7–PTE0) . . . . .	47
1.6.15	Port F I/O Pins (PTF7–PTF0) . . . . .	47
1.6.16	LCD Backplane and Frontplane (BP0–BP2, BP3/FP0, FP1–FP10, FP27–FP32) . . . . .	47

## 1.2 Introduction

The MC68HC908LJ24 is a member of the low-cost, high-performance M68HC08 Family of 8-bit microcontroller units (MCUs). The M68HC08 Family is based on the customer-specified integrated circuit (CSIC) design strategy. All MCUs in the family use the enhanced M68HC08 central processor unit (CPU08) and are available with a variety of modules, memory sizes and types, and package types.

## 1.3 Features

Features of the MC68HC908LJ24 include the following:

- High-performance M68HC08 architecture
- Fully upward-compatible object code with M6805, M146805, and M68HC05 Families
  - 8-MHz at 5V operating voltage
  - 4-MHz at 3.3V operating voltage
- 32.768kHz crystal oscillator clock input with 32MHz internal PLL
- Optional continuous crystal oscillator operation in stop mode
- 24K-bytes user program FLASH memory with security<sup>1</sup> feature
- 768 bytes of on-chip RAM
- Up to 48 general-purpose input/output (I/O) pins:
  - High current 15mA sink capability on 30 pins
- Two 16-bit, 2-channel timer interface modules (TIM1 and TIM2) with selectable input capture, output compare, PWM capability on each channel, and external clock input option (T1CLK and T2CLK)
- Real time clock (RTC) with:
  - Clock, calendar, alarm, and chronograph functions
  - Selectable periodic interrupt requests for seconds, minutes, hours, days, 2-Hz, 4-Hz, 8-Hz, 16-Hz, and 128-Hz

1. No security feature is absolutely secure. However, Motorola strategy is to make reading or copying the FLASH difficult for unauthorized users.

- Temperature drift compensation by user software and external temperature sensor with temperature drift profile from crystal vendor
- Serial communications interface module (SCI) with infrared (IR) encoder/decoder
- Inter-IC Bus interface module (IIC)
- Serial peripheral interface module (SPI)
- $\overline{\text{IRQ}}$  external interrupt pin with integrated pullup
- 8-bit keyboard wakeup port with programmable pullup
- 4/3 backplanes and static with maximum 32/33 frontplanes liquid crystal display (LCD) driver
- 6-channel, 10-bit successive approximation analog-to-digital converter (ADC)
- Resident routines for in-circuit programming and EEPROM emulation
- Low-power design (fully static with stop and wait modes)
- Master reset pin (with integrated pullup) and power-on reset
- Spike filter protection for EMC performance enhancement
- System protection features
  - Optional computer operating properly (COP) reset, driven by internal RC oscillator
  - Low-voltage detection with optional reset or interrupt
  - Illegal opcode detection with reset
  - Illegal address detection with reset
- 80-pin quad flat pack (QFP), 80-pin low-profile quad flat pack (LQFP), 64-pin quad flat pack (QFP), and 64-pin low-profile quad flat pack (LQFP)

- Specific features of the MC68HC908LJ24 in 64-pin packages are:
  - 40 general-purpose I/Os only
  - High current 15-mA sink capability on 22 pins
  - 4/3 backplanes and static with maximum 26 or 27 frontplanes LCD driver

Features of the CPU08 include the following:

- Enhanced HC05 programming model
- Extensive loop control functions
- 16 addressing modes (eight more than the HC05)
- 16-bit Index register and stack pointer
- Memory-to-memory data transfers
- Fast 8 × 8 multiply instruction
- Fast 16/8 divide instruction
- Binary-coded decimal (BCD) instructions
- Optimization for controller applications
- Efficient C language support

## 1.4 MCU Block Diagram

**Figure 1-1** shows the structure of the MC68HC908LJ24.



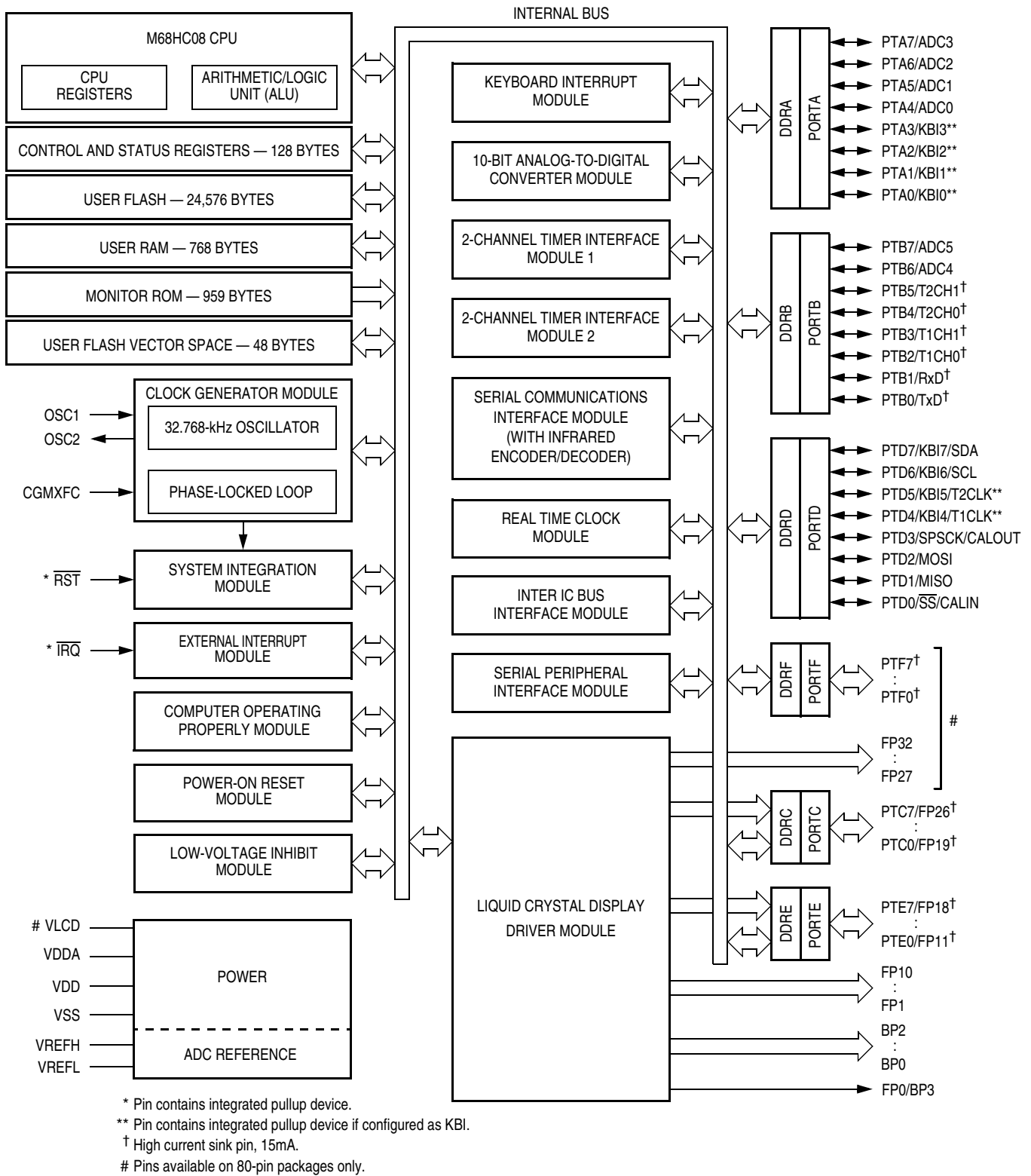


Figure 1-1. MC68HC908LJ24 Block Diagram

General Description

1.5 Pin Assignments

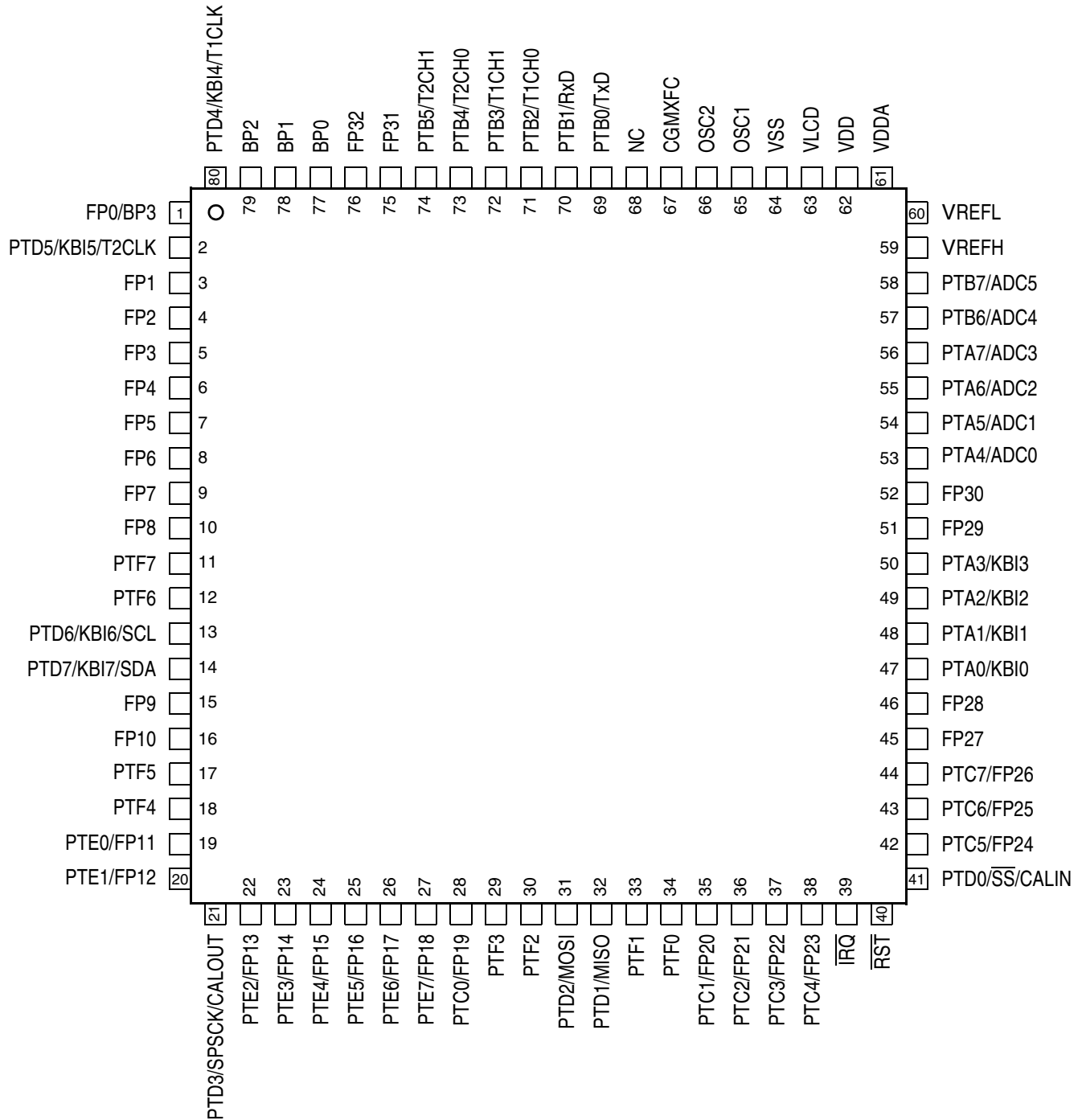


Figure 1-2. 80-Pin QFP and LQFP Pin Assignment

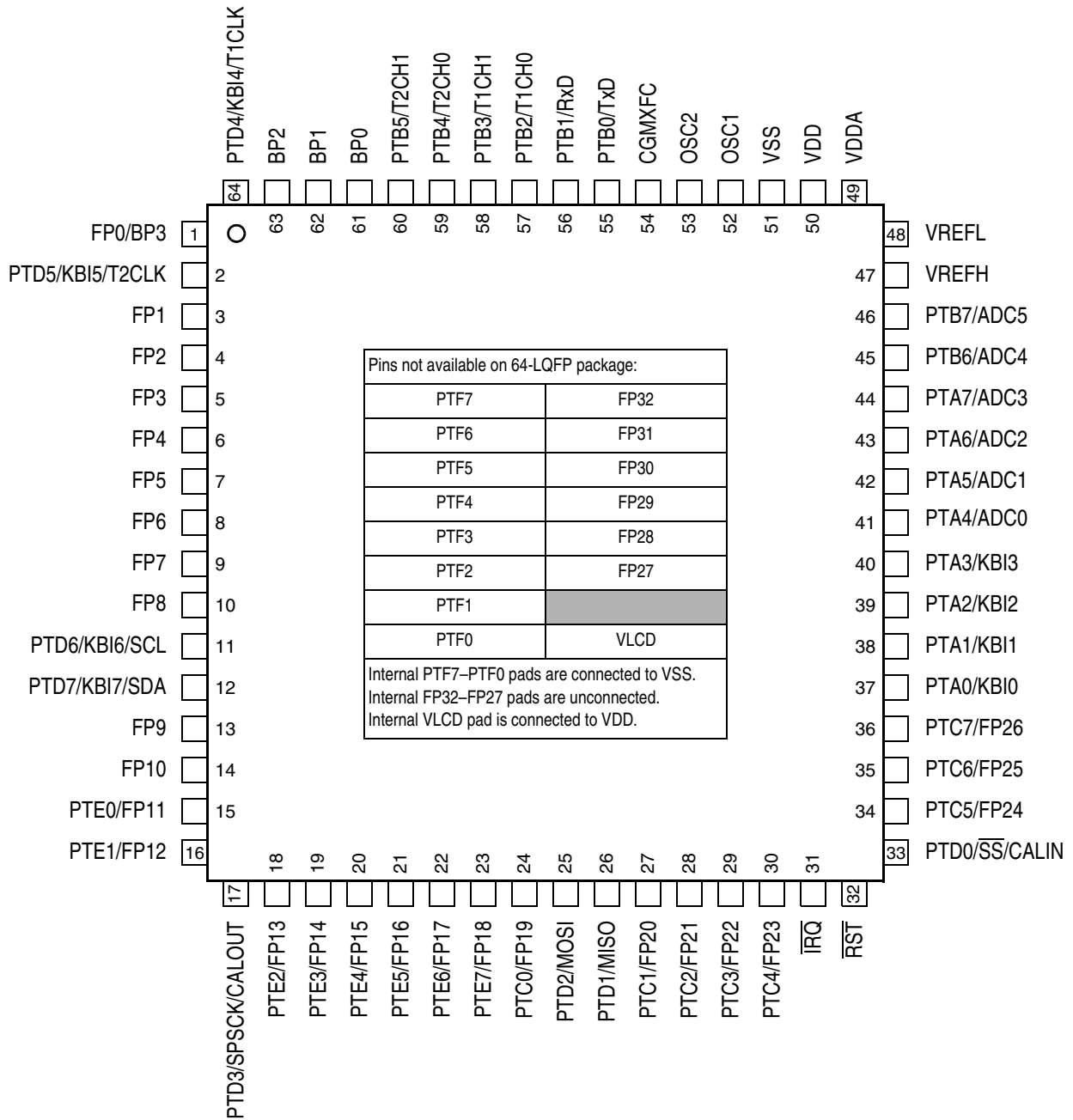


Figure 1-3. 64-pin QFP and LQFP Pin Assignment

## 1.6 Pin Functions

Description of pin functions are provided here.

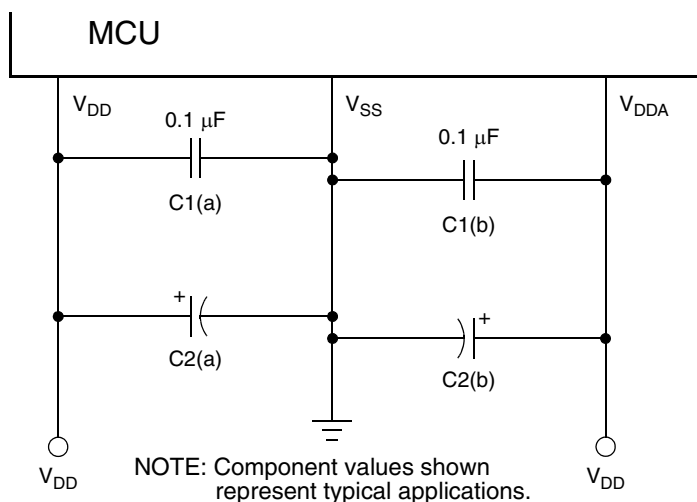
### 1.6.1 Power Supply Pins ( $V_{DD}$ and $V_{SS}$ )

$V_{DD}$  and  $V_{SS}$  are the power supply and ground pins. The MCU operates from a single power supply.

Fast signal transitions on MCU pins place high, short-duration current demands on the power supply. To prevent noise problems, take special care to provide power supply bypassing at the MCU as **Figure 1-4** shows. Place the C1 bypass capacitor as close to the MCU as possible. Use a high-frequency-response ceramic capacitor for C1. C2 is an optional bulk current bypass capacitor for use in applications that require the port pins to source high current levels.  $V_{SS}$  must be grounded for proper MCU operation.

### 1.6.2 Analog Power Supply Pin ( $V_{DDA}$ )

$V_{DDA}$  is the voltage supply for the analog parts of the MCU. Connect the  $V_{DDA}$  pin to the same voltage potential as  $V_{DD}$ . For maximum noise immunity, route  $V_{DDA}$  via a separate trace and place bypass capacitors as close as possible to the package (see **Figure 1-4**).



**Figure 1-4. Power Supply Bypassing**

### 1.6.3 LCD Bias Voltage ( $V_{LCD}$ )

$V_{LCD}$  is the bias voltage supply for the LCD driver module. Connect the  $V_{LCD}$  pin to the same voltage potential as  $V_{DD}$ . For maximum noise immunity, route  $V_{LCD}$  via a separate trace and place bypass capacitors as close as possible to the package. See [Section 17. Liquid Crystal Display \(LCD\) Driver](#).

### 1.6.4 Oscillator Pins (OSC1 and OSC2)

The OSC1 and OSC2 pins are the connections for the on-chip oscillator circuit. The OSC1 pin contains a schmitt-trigger and a spike filter for improved EMC performance. See [Section 7. Oscillator \(OSC\)](#).

### 1.6.5 External Reset Pin ( $\overline{RST}$ )

A logic 0 on the  $\overline{RST}$  pin forces the MCU to a known start-up state.  $\overline{RST}$  is bidirectional, allowing a reset of the entire system. It is driven low when any internal reset source is asserted. A Schmitt-trigger and a spike filter is associated with this pin so that the device is more robust to EMC noise. This pin also contains an internal pullup resistor. See [9.4 Reset and System Initialization](#).

### 1.6.6 External Interrupt Pin ( $\overline{IRQ}$ )

$\overline{IRQ}$  is an asynchronous external interrupt pin. This pin contains an internal pullup resistor. See [Section 19. External Interrupt \(IRQ\)](#).

### 1.6.7 External Filter Capacitor Pin (CGMXFC)

CGMXFC is an external filter capacitor connection for the CGM. See [8.4.9 CGM External Connections](#).

### 1.6.8 ADC Voltage High Reference Pin ( $V_{REFH}$ )

$V_{REFH}$  is the voltage input pin for the ADC voltage high reference. See [16.7.4 ADC Voltage Reference High Pin \( \$V\_{REFH}\$ \)](#).

### 1.6.9 ADC Voltage Low Reference Pin ( $V_{REFL}$ )

$V_{REFL}$  is the voltage input pin for the ADC voltage low reference.  
See [16.7.5 ADC Voltage Reference Low Pin \( \$V\_{REFL}\$ \)](#).

### 1.6.10 Port A Input/Output (I/O) Pins (PTA7–PTA0)

PTA7–PTA0 are special function, bidirectional port pins. See [18.3 Port A](#).  
PTA7/ADC3–PTA4/ADC0 are shared with ADC, and  
PTA3/KBI3–PTA0/KBI0 are shared with the KBI module.

### 1.6.11 Port B I/O Pins (PTB7–PTB0)

PTB7–PTB0 are special function, bidirectional port pins, with high current sink capability on PTB5–PTB0. See [18.4 Port B](#).  
PTB1/RxD–PTB0/TxD are shared with the SCI module,  
PTB5/T2CH1–PTB4/T2CH0 are shared with the TIM2,  
PTB3/T1CH1–PTB2/T1CH0 are shared with the TIM1,  
PTB7/ADC5–PTB6/ADC4 are shared with the ADC.

### 1.6.12 Port C I/O Pins (PTC7–PTC0)

PTC7–PTC0 are special function, bidirectional port pins, with high current sink capability. See [18.5 Port C](#).  
PTC7/FP26–PTC0/FP19 are shared with the LCD frontplane drivers.

### 1.6.13 Port D I/O Pins (PTD7–PTD0)

PTD7–PTD0 are special function, bidirectional port pins.  
PTD7/KBI7/SDA–PTD6/KBI6/SCL are shared with the KBI and IIC modules. See [18.6 Port D](#).  
PTD5/KBI5/T2CLK–PTD4/KBI4/T1CLK are shared with the KBI, TIM1, and TIM2 modules.  
PTD3/SPSCK/CALOUT–PTD0/ $\overline{SS}$ /CALIN are shared with the SPI and RTC modules.

**1.6.14 Port E I/O Pins (PTE7–PTE0)**

PTE7–PTE0 are special function, bidirectional port pins, with high current sink capability. See [18.7 Port E](#).

PTE7/FP18–PTE0/FP11 are shared with the LCD frontplane drivers.

**1.6.15 Port F I/O Pins (PTF7–PTF0)**

PTF7–PTF0 are general purpose bidirectional port pins with high current sink capability. See [18.8 Port F](#).

**1.6.16 LCD Backplane and Frontplane (BP0–BP2, BP3/FP0, FP1–FP10, FP27–FP32)**

BP0–BP2 are the LCD backplane driver pins and FP1–FP10 and FP27–FP32 are the frontplane driver pins. FP0/BP3 is the shared driver pin between FP0 and BP3.

See [Section 17. Liquid Crystal Display \(LCD\) Driver](#).





## Section 2. Memory Map

### 2.1 Contents

2.2	Introduction . . . . .	49
2.3	Unimplemented Memory Locations . . . . .	49
2.4	Reserved Memory Locations . . . . .	50
2.5	Input/Output (I/O) Section. . . . .	50

### 2.2 Introduction

The CPU08 can address 64k-bytes of memory space. The memory map, shown in **Figure 2-1**, includes:

- 24,576 bytes of user FLASH memory
- 768 bytes of random-access memory (RAM)
- 48 bytes of user-defined vectors
- 959 bytes of monitor ROM

### 2.3 Unimplemented Memory Locations

Accessing an unimplemented location can cause an illegal address reset. In the memory map (**Figure 2-1**) and in register figures in this document, unimplemented locations are shaded.

## 2.4 Reserved Memory Locations

Accessing a reserved location can have unpredictable effects on MCU operation. In [Figure 2-2](#) and in register figures in this document, reserved locations are marked with the word Reserved or with the letter R.

## 2.5 Input/Output (I/O) Section

Most of the control, status, and data registers are in the zero page \$0000–\$007F. Additional I/O registers have the following addresses:

- \$FE00; SIM break status register, SBSR
- \$FE01; SIM reset status register, SRSR
- \$FE03; SIM break flag control register, SBFCR
- \$FE04; Interrupt status register 1, INT1
- \$FE05; Interrupt status register 2, INT2
- \$FE06; Interrupt status register 3, INT3
- \$FE07; Reserved
- \$FE08; FLASH control register, FLCR
- \$FE09; Reserved
- \$FE0A; Reserved
- \$FE0B; Reserved
- \$FE0C; break address register high, BRKH
- \$FE0D; break address register low, BRKL
- \$FE0E; break status and control register, BRKSCR
- \$FE0F; LVI status register, LVISR
- \$FFCF; FLASH block protect register, FLBPR (FLASH register)
- \$FFFF; COP control register, COPCTL

Data registers are shown in [Figure 2-2](#), [Table 2-1](#) is a list of vector locations.

\$0000 ↓ \$007F	I/O Registers 128 Bytes
\$0080 ↓ \$037F	RAM 768 Bytes
\$0380 ↓ \$8FFF	Unimplemented 35,968 Bytes
\$9000 ↓ \$EFFF	User FLASH Memory 24,576 Bytes
\$F000 ↓ \$FBFF	Unimplemented 3,072 Bytes
\$FC00 ↓ \$FDFF	Monitor ROM 1 512 Bytes
\$FE00	SIM Break Status Register (SBSR)
\$FE01	SIM Reset Status Register (SRSR)
\$FE02	Reserved
\$FE03	SIM Break Flag Control Register (SBFCR)
\$FE04	Interrupt Status Register 1 (INT1)
\$FE05	Interrupt Status Register 2 (INT2)
\$FE06	Interrupt Status Register 3 (INT3)
\$FE07	Reserved
\$FE08	FLASH Control Register (FLCR)
\$FE09	Reserved
\$FE0A	Reserved
\$FE0B	Reserved
\$FE0C	Break Address Register High (BRKH)
\$FE0D	Break Address Register Low (BRKL)
\$FE0E	Break Status and Control Register (BRKSCR)
\$FE0F	LVI Status Register (LVISR)
\$FE10 ↓ \$FFCE	Monitor ROM 2 447 Bytes
\$FFCF	FLASH Block Protect Register (FLBPR)
\$FFD0 ↓ \$FFFF	User Vectors 48 Bytes

**Figure 2-1. Memory Map**

Memory Map

Freescale Semiconductor, Inc.

Addr.	Register Name	Bit 7	6	5	4	3	2	1	Bit 0	
\$0000	Port A Data Register (PTA)	Read:	PTA7	PTA6	PTA5	PTA4	PTA3	PTA2	PTA1	PTA0
		Write:								
		Reset:	U	U	U	U	U	U	U	U
\$0001	Port B Data Register (PTB)	Read:	PTB7	PTB6	PTB5	PTB4	PTB3	PTB2	PTB1	PTB0
		Write:								
		Reset:	U	U	U	U	U	U	U	U
\$0002	Port C Data Register (PTC)	Read:	PTC7	PTC6	PTC5	PTC4	PTC3	PTC2	PTC1	PTC0
		Write:								
		Reset:	U	U	U	U	U	U	U	U
\$0003	Port D Data Register (PTD)	Read:	PTD7	PTD6	PTD5	PTD4	PTD3	PTD2	PTD1	PTD0
		Write:								
		Reset:	U	U	U	U	U	U	U	U
\$0004	Data Direction Register A (DDRA)	Read:	DDRA7	DDRA6	DDRA5	DDRA4	DDRA3	DDRA2	DDRA1	DDRA0
		Write:								
		Reset:	0	0	0	0	0	0	0	0
\$0005	Data Direction Register B (DDRB)	Read:	DDRB7	DDRB6	DDRB5	DDRB4	DDRB3	DDRB2	DDRB1	DDRB0
		Write:								
		Reset:	0	0	0	0	0	0	0	0
\$0006	Data Direction Register C (DDRC)	Read:	DDRC7	DDRC6	DDRC5	DDRC4	DDRC3	DDRC2	DDRC1	DDRC0
		Write:								
		Reset:	0	0	0	0	0	0	0	0
\$0007	Data Direction Register D (DDRD)	Read:	DDRD7	DDRD6	DDRD5	DDRD4	DDRD3	DDRD2	DDRD1	DDRD0
		Write:								
		Reset:	0	0	0	0	0	0	0	0
\$0008	Port E Data Register (PTE)	Read:	PTE7	PTE6	PTE5	PTE4	PTE3	PTE2	PTE1	PTE0
		Write:								
		Reset:	U	U	U	U	U	U	U	U
\$0009	Data Direction Register E (DDRE)	Read:	DDRE7	DDRE6	DDRE5	DDRE4	DDRE3	DDRE2	DDRE1	DDRE0
		Write:								
		Reset:	0	0	0	0	0	0	0	0

U = Unaffected      X = Indeterminate       = Unimplemented      R = Reserved

Figure 2-2. Control, Status, and Data Registers (Sheet 1 of 13)

Addr.	Register Name	Bit 7	6	5	4	3	2	1	Bit 0	
\$000A	Port F Data Register (PTF)	Read:								
		Write:	PTF7	PTF6	PTF5	PTF4	PTF3	PTF2	PTF1	PTF0
		Reset:	U	U	U	U	U	U	U	U
\$000B	Data Direction Register F (DDRF)	Read:								
		Write:	DDRF7	DDRF6	DDRF5	DDRF4	DDRF3	DDRF2	DDRF1	DDRF0
		Reset:	0	0	0	0	0	0	0	0
\$000C	Port-B LED Control Register (LEDB)	Read:	0	0	LEDB5	LEDB4	LEDB3	LEDB2	LEDB1	LEDB0
		Write:								
		Reset:	0	0	0	0	0	0	0	0
\$000D	Port-C LED Control Register (LEDC)	Read:								
		Write:	LEDC7	LEDC6	LEDC5	LEDC4	LEDC3	LEDC2	LEDC1	LEDC0
		Reset:	0	0	0	0	0	0	0	0
\$000E	Port-E LED Control Register (LEDE)	Read:								
		Write:	LEDE7	LEDE6	LEDE5	LEDE4	LEDE3	LEDE2	LEDE1	LEDE0
		Reset:	0	0	0	0	0	0	0	0
\$000F	Port-F LED Control Register (LEDF)	Read:								
		Write:	LEDF7	LEDF6	LEDF5	LEDF4	LEDF3	LEDF2	LEDF1	LEDF0
		Reset:	0	0	0	0	0	0	0	0
\$0010	SPI Control Register (SPCR)	Read:								
		Write:	SPRIE	R	SPMSTR	CPOL	CPHA	SPWOM	SPE	SPTIE
		Reset:	0	0	1	0	1	0	0	0
\$0011	SPI Status and Control Register (SPSCR)	Read:								
		Write:	SPRF	ERRIE	OVRF	MODF	SPTIE	MODFEN	SPR1	SPR0
		Reset:	0	0	0	0	1	0	0	0
\$0012	SPI Data Register (SPDR)	Read:	R7	R6	R5	R4	R3	R2	R1	R0
		Write:	T7	T6	T5	T4	T3	T2	T1	T0
		Reset:	U	U	U	U	U	U	U	U
\$0013	SCI Control Register 1 (SCC1)	Read:			0					
		Write:	LOOPS	ENSCI		M	WAKE	ILTY	PEN	PTY
		Reset:	0	0	0	0	0	0	0	0

U = Unaffected      X = Indeterminate      [Grey Box] = Unimplemented      [Box with R] = Reserved

Figure 2-2. Control, Status, and Data Registers (Sheet 2 of 13)

Memory Map

Addr.	Register Name	Bit 7	6	5	4	3	2	1	Bit 0	
\$0014	SCI Control Register 2 (SCC2)	Read:	SCTIE	TCIE	SCRIE	ILIE	TE	RE	RWU	SBK
		Write:								
		Reset:	0	0	0	0	0	0	0	0
\$0015	SCI Control Register 3 (SCC3)	Read:	R8	T8	DMARE	DMATE	ORIE	NEIE	FEIE	PEIE
		Write:								
		Reset:	U	U	0	0	0	0	0	0
\$0016	SCI Status Register 1 (SCS1)	Read:	SCTE	TC	SCRF	IDLE	OR	NF	FE	PE
		Write:								
		Reset:	1	1	0	0	0	0	0	0
\$0017	SCI Status Register 2 (SCS2)	Read:	0	0	0	0	0	0	BKF	RPF
		Write:								
		Reset:	0	0	0	0	0	0	0	0
\$0018	SCI Data Register (SCDR)	Read:	R7	R6	R5	R4	R3	R2	R1	R0
		Write:	T7	T6	T5	T4	T3	T2	T1	T0
		Reset:	U	U	U	U	U	U	U	U
\$0019	SCI Baud Rate Register (SCBR)	Read:		0						
		Write:	CKS		SCP1	SCP0	R	SCR2	SCR1	SCR0
		Reset:	0	0	0	0	0	0	0	0
\$001A	SCI Infrared Control Register (SCIRCR)	Read:	R	0	0	0				
		Write:					CKTST	TNP1	TNP0	IREN
		Reset:	0	0	0	0	0	0	0	0
\$001B	Keyboard Status and Control Register (KBSCR)	Read:	0	0	0	0	KEYF	0		
		Write:						ACKK	IMASKK	MODEK
		Reset:	0	0	0	0	0	0	0	0
\$001C	Keyboard Interrupt Enable Register (KBIER)	Read:	KBIE7	KBIE6	KBIE5	KBIE4	KBIE3	KBIE2	KBIE1	KBIE0
		Write:								
		Reset:	0	0	0	0	0	0	0	0
\$001D	Configuration Register 2 (CONFIG2) <sup>†</sup>	Read:	PEE	STOP_IRCDIS	STOP_XCLKEN	DIV2CLK	PCEH	PCEL	LVISEL1	LVISEL0
		Write:								
		Reset:	0	0	0	0	0	0	0 <sup>††</sup>	1 <sup>††</sup>

U = Unaffected      X = Indeterminate      [Grey Box] = Unimplemented      [R] = Reserved

Figure 2-2. Control, Status, and Data Registers (Sheet 3 of 13)

Addr.	Register Name	Bit 7	6	5	4	3	2	1	Bit 0	
\$001E	IRQ Status and Control Register (INTSCR)	Read:	0	0	0	0	IRQF	0	IMASK	MODE
		Write:	[Unimplemented]					ACK		
		Reset:	0	0	0	0	0	0	0	0
\$001F	Configuration Register 1 (CONFIG1) <sup>†</sup>	Read:	COPRS	LVISTOP	LVIRSTD	LVIPWRD	0	SSREC	STOP	COPD
		Write:	[Unimplemented]							
		Reset:	0	0	0	0 <sup>††</sup>	0	0	0	0

<sup>†</sup> One-time writable register after each reset.

<sup>††</sup> Reset by POR only.

\$0020	Timer 1 Status and Control Register (T1SC)	Read:	TOF	TOIE	TSTOP	0	0	PS2	PS1	PS0
		Write:	0			TRST	[Unimplemented]			
		Reset:	0	0	1	0	0	0	0	0
\$0021	Timer 1 Counter Register High (T1CNTH)	Read:	Bit 15	14	13	12	11	10	9	Bit 8
		Write:	[Unimplemented]							
		Reset:	0	0	0	0	0	0	0	0
\$0022	Timer 1 Counter Register Low (T1CNTL)	Read:	Bit 7	6	5	4	3	2	1	Bit 0
		Write:	[Unimplemented]							
		Reset:	0	0	0	0	0	0	0	0
\$0023	Timer 1 Counter Modulo Register High (T1MODH)	Read:	Bit 15	14	13	12	11	10	9	Bit 8
		Write:	[Unimplemented]							
		Reset:	1	1	1	1	1	1	1	1
\$0024	Timer 1 Counter Modulo Register Low (T1MODL)	Read:	Bit 7	6	5	4	3	2	1	Bit 0
		Write:	[Unimplemented]							
		Reset:	1	1	1	1	1	1	1	1
\$0025	Timer 1 Channel 0 Status and Control Register (T1SC0)	Read:	CH0F	CH0IE	MS0B	MS0A	ELS0B	ELS0A	TOV0	CH0MAX
		Write:	0							
		Reset:	0	0	0	0	0	0	0	0
\$0026	Timer 1 Channel 0 Register High (T1CH0H)	Read:	Bit 15	14	13	12	11	10	9	Bit 8
		Write:	[Unimplemented]							
		Reset:	X	X	X	X	X	X	X	X

U = Unaffected      X = Indeterminate      [Unimplemented] = Unimplemented      [R] = Reserved

Figure 2-2. Control, Status, and Data Registers (Sheet 4 of 13)

Memory Map

Freescale Semiconductor, Inc.

Addr.	Register Name	Bit 7	6	5	4	3	2	1	Bit 0	
\$0027	Timer 1 Channel 0 Register Low (T1CH0L)	Read:	Bit 7	6	5	4	3	2	1	Bit 0
		Write:								
		Reset:	X	X	X	X	X	X	X	X
\$0028	Timer 1 Channel 1 Status and Control Register (T1SC1)	Read:	CH1F	CH1IE	0	MS1A	ELS1B	ELS1A	TOV1	CH1MAX
		Write:	0							
		Reset:	0	0	0	0	0	0	0	0
\$0029	Timer 1 Channel 1 Register High (T1CH1H)	Read:	Bit 15	14	13	12	11	10	9	Bit 8
		Write:								
		Reset:	X	X	X	X	X	X	X	X
\$002A	Timer 1 Channel 1 Register Low (T1CH1L)	Read:	Bit 7	6	5	4	3	2	1	Bit 0
		Write:								
		Reset:	X	X	X	X	X	X	X	X
\$002B	Timer 2 Status and Control Register (T2SC)	Read:	TOF	TOIE	TSTOP	0	0	PS2	PS1	PS0
		Write:	0			TRST				
		Reset:	0	0	1	0	0	0	0	0
\$002C	Timer 2 Counter Register High (T2CNTH)	Read:	Bit 15	14	13	12	11	10	9	Bit 8
		Write:								
		Reset:	0	0	0	0	0	0	0	0
\$002D	Timer 2 Counter Register Low (T2CNTL)	Read:	Bit 7	6	5	4	3	2	1	Bit 0
		Write:								
		Reset:	0	0	0	0	0	0	0	0
\$002E	Timer 2 Counter Modulo Register High (T2MODH)	Read:	Bit 15	14	13	12	11	10	9	Bit 8
		Write:								
		Reset:	1	1	1	1	1	1	1	1
\$002F	Timer 2 Counter Modulo Register Low (T2MODL)	Read:	Bit 7	6	5	4	3	2	1	Bit 0
		Write:								
		Reset:	1	1	1	1	1	1	1	1
\$0030	Timer 2 Channel 0 Status and Control Register (T2SC0)	Read:	CH0F	CH0IE	MS0B	MS0A	ELS0B	ELS0A	TOV0	CH0MAX
		Write:	0							
		Reset:	0	0	0	0	0	0	0	0

U = Unaffected      X = Indeterminate      [Grey Box] = Unimplemented      [R Box] = Reserved

Figure 2-2. Control, Status, and Data Registers (Sheet 5 of 13)



Addr.	Register Name	Bit 7	6	5	4	3	2	1	Bit 0	
\$0031	Timer 2 Channel 0 Register High (T2CH0H)	Read:	Bit 15	14	13	12	11	10	9	Bit 8
		Write:								
		Reset:	X	X	X	X	X	X	X	X
\$0032	Timer 2 Channel 0 Register Low (T2CH0L)	Read:	Bit 7	6	5	4	3	2	1	Bit 0
		Write:								
		Reset:	X	X	X	X	X	X	X	X
\$0033	Timer 2 Channel 1 Status and Control Register (T2SC1)	Read:	CH1F	CH1IE	0	MS1A	ELS1B	ELS1A	TOV1	CH1MAX
		Write:	0							
		Reset:	0	0	0	0	0	0	0	0
\$0034	Timer 2 Channel 1 Register High (T2CH1H)	Read:	Bit 15	14	13	12	11	10	9	Bit 8
		Write:								
		Reset:	X	X	X	X	X	X	X	X
\$0035	Timer 2 Channel 1 Register Low (T2CH1L)	Read:	Bit 7	6	5	4	3	2	1	Bit 0
		Write:								
		Reset:	X	X	X	X	X	X	X	X
\$0036	PLL Control Register (PTCL)	Read:	PLLIE	PLL F	PLLON	BCS	PRE1	PRE0	VPR1	VPR0
		Write:								
		Reset:	0	0	1	0	0	0	0	0
\$0037	PLL Bandwidth Control Register (PBWC)	Read:	AUTO	LOCK	ACQ	0	0	0	0	R
		Write:								
		Reset:	0	0	0	0	0	0	0	0
\$0038	PLL Multiplier Select Register High (PMSH)	Read:	0	0	0	0	MUL11	MUL10	MUL9	MUL8
		Write:								
		Reset:	0	0	0	0	0	0	0	0
\$0039	PLL Multiplier Select Register Low (PMSL)	Read:	MUL7	MUL6	MUL5	MUL4	MUL3	MUL2	MUL1	MUL0
		Write:								
		Reset:	0	1	0	0	0	0	0	0
\$003A	PLL VCO Range Select Register (PMRS)	Read:	VRS7	VRS6	VRS5	VRS4	VRS3	VRS2	VRS1	VRS0
		Write:								
		Reset:	0	1	0	0	0	0	0	0

U = Unaffected      X = Indeterminate      [ ] = Unimplemented      [ R ] = Reserved

Figure 2-2. Control, Status, and Data Registers (Sheet 6 of 13)

Memory Map

Addr.	Register Name		Bit 7	6	5	4	3	2	1	Bit 0
\$003B	PLL Reference Divider Select Register (PMDS)	Read:	0	0	0	0	RDS3	RDS2	RDS1	RDS0
		Write:								
		Reset:	0	0	0	0	0	0	0	1
\$003C	ADC Status and Control Register (ADCSR)	Read:	COCO	AIEN	ADCO	ADCH4	ADCH3	ADCH2	ADCH1	ADCH0
		Write:								
		Reset:	0	0	0	1	1	1	1	1
\$003D	ADC Data Register high (ADRH)	Read:	ADx	ADx	ADx	ADx	ADx	ADx	ADx	ADx
		Write:	R	R	R	R	R	R	R	R
		Reset:	0	0	0	0	0	0	0	0
\$003E	ADC Data Register low (ADRL)	Read:	ADx	ADx	ADx	ADx	ADx	ADx	ADx	ADx
		Write:	R	R	R	R	R	R	R	R
		Reset:	0	0	0	0	0	0	0	0
\$003F	ADC Clock Control Register (ADCLK)	Read:	ADIV2	ADIV1	ADIV0	ADICLK	MODE1	MODE0	0	0
		Write:								R
		Reset:	0	0	0	0	0	1	0	0
\$0040	RTC Calibration Control Register (RTCCOMR)	Read:	0	0	CAL	AUTOCAL	OUTF1	OUTF0	0	0
		Write:	R	R					RTCWE1	RTCWE0
		Reset:	0	0	0	0	0	0	1	0
\$0041	RTC Calibration Data Register (RTCCDAT)	Read:	EOVL	0	E5	E4	E3	E2	E1	E0
		Write:								
		Reset:	U	0	U	U	U	U	U	U
\$0042	RTC Control Register 1 (RTCCR1)	Read:	ALMIE	CHRIE	DAYIE	HRIE	MINIE	SECIE	TB1IE	TB2IE
		Write:								
		Reset:	0	0	0	0	0	0	0	0
\$0043	RTC Control Register 2 (RTCCR2)	Read:	COMEN	0	CHRE	RTCE	TBH	0	0	0
		Write:		CHRCLR						
		Reset:	U	0	0	0††	0	0	0	0

†† Reset by POR only.

U = Unaffected      X = Indeterminate      [Grey Box] = Unimplemented      [R Box] = Reserved

Figure 2-2. Control, Status, and Data Registers (Sheet 7 of 13)

Addr.	Register Name	Bit 7	6	5	4	3	2	1	Bit 0	
\$0044	RTC Status Register (RTCSR)	Read:	ALMF	CHRF	DAYF	HRF	MINF	SECF	TB1F	TB2F
		Write:								
		Reset:	0	0	0	0	0	0	0	0
\$0045	Alarm Minute register (ALMR)	Read:	0	0	AM5	AM4	AM3	AM2	AM1	AM0
		Write:								
		Reset:	0	0	U	U	U	U	U	U
\$0046	Alarm Hour register (ALHR)	Read:	0	0	0	AH4	AH3	AH2	AH1	AH0
		Write:								
		Reset:	0	0	0	U	U	U	U	U
\$0047	Second Register (SECR)	Read:	0	0	SEC5	SEC4	SEC3	SEC2	SEC1	SEC0
		Write:								
		Reset:	0	0	U	U	U	U	U	U
\$0048	Minute Register (MINR)	Read:	0	0	MIN5	MIN4	MIN3	MIN2	MIN1	MIN0
		Write:								
		Reset:	0	0	U	U	U	U	U	U
\$0049	Hour Register (HRR)	Read:	0	0	0	HR4	HR3	HR2	HR1	HR0
		Write:								
		Reset:	0	0	0	U	U	U	U	U
\$004A	Day Register (DAYR)	Read:	0	0	0	DAY4	DAY3	DAY2	DAY1	DAY0
		Write:								
		Reset:	0	0	0	U	U	U	U	U
\$004B	Month Register (MTHR)	Read:	0	0	0	0	MTH3	MTH2	MTH1	MTH0
		Write:								
		Reset:	0	0	0	0	U	U	U	U
\$004C	Year Register (YRR)	Read:								
		Write:	YR7	YR6	YR5	YR4	YR3	YR2	YR1	YR0
		Reset:	U	U	U	U	U	U	U	U
\$004D	Day-Of-Week Register (DOWR)	Read:	0	0	0	0	0	DOW2	DOW1	DOW0
		Write:								
		Reset:	0	0	0	0	0	U	U	U

U = Unaffected      X = Indeterminate       = Unimplemented       = Reserved

**Figure 2-2. Control, Status, and Data Registers (Sheet 8 of 13)**

Memory Map

Addr.	Register Name	Bit 7	6	5	4	3	2	1	Bit 0	
\$004E	Chronograph Data Register (CHRR)	Read:	0	CHR6	CHR5	CHR4	CHR3	CHR2	CHR1	CHR0
		Write:								
		Reset:	0	0	0	0	0	0	0	0
\$004F	LCD Clock Register (LCDCLK)	Read:	0	FCCTL1	FCCTL0	DUTY1	DUTY0	LCLK2	LCLK1	LCLK0
		Write:								
		Reset:	0	0	0	0	0	0	0	0
\$0050	Reserved	Read:	R	R	R	R	R	R	R	R
		Write:								
		Reset:								
\$0051	LCD Control Register (LCDCR)	Read:	LCDE	0	FC	LC	LCCON3	LCCON2	LCCON1	LCCON0
		Write:								
		Reset:	0	0	0	0	0	0	0	0
\$0052	LCD Data Register 1 (LDAT1)	Read:	F1B3	F1B2	F1B1	F1B0	F0B3	F0B2	F0B1	F0B0
		Write:								
		Reset:	U	U	U	U	U	U	U	U
\$0053	LCD Data Register 2 (LDAT2)	Read:	F3B3	F3B2	F3B1	F3B0	F2B3	F2B2	F2B1	F2B0
		Write:								
		Reset:	U	U	U	U	U	U	U	U
\$0054	LCD Data Register 3 (LDAT3)	Read:	F5B3	F5B2	F5B1	F5B0	F4B3	F4B2	F4B1	F4B0
		Write:								
		Reset:	U	U	U	U	U	U	U	U
\$0055	LCD Data Register 4 (LDAT4)	Read:	F7B3	F7B2	F7B1	F7B0	F6B3	F6B2	F6B1	F6B0
		Write:								
		Reset:	U	U	U	U	U	U	U	U
\$0056	LCD Data Register 5 (LDAT5)	Read:	F9B3	F9B2	F9B1	F9B0	F8B3	F8B2	F8B1	F8B0
		Write:								
		Reset:	U	U	U	U	U	U	U	U
\$0057	LCD Data Register 6 (LDAT6)	Read:	F11B3	F11B2	F11B1	F11B0	F10B3	F10B2	F10B1	F10B0
		Write:								
		Reset:	U	U	U	U	U	U	U	U

U = Unaffected      X = Indeterminate      [Grey Box] = Unimplemented      [R Box] = Reserved

Figure 2-2. Control, Status, and Data Registers (Sheet 9 of 13)

Addr.	Register Name	Bit 7	6	5	4	3	2	1	Bit 0	
\$0058	LCD Data Register 7 (LDAT7)	Read:	F13B3	F13B2	F13B1	F13B0	F12B3	F12B2	F12B1	F12B0
		Write:								
		Reset:	U	U	U	U	U	U	U	U
\$0059	LCD Data Register 8 (LDAT8)	Read:	F15B3	F15B2	F15B1	F15B0	F14B3	F14B2	F14B1	F14B0
		Write:								
		Reset:	U	U	U	U	U	U	U	U
\$005A	LCD Data Register 9 (LDAT9)	Read:	F17B3	F17B2	F17B1	F17B0	F16B3	F16B2	F16B1	F16B0
		Write:								
		Reset:	U	U	U	U	U	U	U	U
\$005B	LCD Data Register 10 (LDAT10)	Read:	F19B3	F19B2	F19B1	F19B0	F18B3	F18B2	F18B1	F18B0
		Write:								
		Reset:	U	U	U	U	U	U	U	U
\$005C	LCD Data Register 11 (LDAT11)	Read:	F21B3	F21B2	F21B1	F21B0	F20B3	F20B2	F20B1	F20B0
		Write:								
		Reset:	U	U	U	U	U	U	U	U
\$005D	LCD Data Register 12 (LDAT12)	Read:	F23B3	F23B2	F23B1	F23B0	F22B3	F22B2	F22B1	F22B0
		Write:								
		Reset:	U	U	U	U	U	U	U	U
\$005E	LCD Data Register 13 (LDAT13)	Read:	F25B3	F25B2	F25B1	F25B0	F24B3	F24B2	F24B1	F24B0
		Write:								
		Reset:	U	U	U	U	U	U	U	U
\$005F	LCD Data Register 14 (LDAT14)	Read:	F27B3	F27B2	F27B1	F27B0	F26B3	F26B2	F26B1	F26B0
		Write:								
		Reset:	U	U	U	U	U	U	U	U
\$0060	LCD Data Register 15 (LDAT15)	Read:	F29B3	F29B2	F29B1	F29B0	F28B3	F28B2	F28B1	F28B0
		Write:								
		Reset:	U	U	U	U	U	U	U	U
\$0061	LCD Data Register 16 (LDAT16)	Read:	F31B3	F31B2	F31B1	F31B0	F30B3	F30B2	F30B1	F30B0
		Write:								
		Reset:	U	U	U	U	U	U	U	U

U = Unaffected      X = Indeterminate       = Unimplemented      R = Reserved

Figure 2-2. Control, Status, and Data Registers (Sheet 10 of 13)

Memory Map

Addr.	Register Name	Bit 7	6	5	4	3	2	1	Bit 0	
\$0062	LCD Data Register 17 (LDAT17)	Read:					F32B3	F32B2	F32B1	F32B0
		Write:								
		Reset:					U	U	U	U
\$0063 to \$0069	Unimplemented	Read:								
		Write:								
		Reset:								
\$006A	MMIIC Master Control Register (MIMCR)	Read:	MMALIF	MMNAKIF	MMBB	MMAST	MMRW	MMBR2	MMBR1	MMBR0
		Write:	0	0						
		Reset:	0	0	0	0	0	0	0	0
\$006B	MMIIC Address Register (MMADR)	Read:	MMAD7	MMAD6	MMAD5	MMAD4	MMAD3	MMAD2	MMAD1	MMEXTAD
		Write:								
		Reset:	1	0	1	0	0	0	0	0
\$006C	MMIIC Control Register (MMCR)	Read:	MMEN	MMIEN	0	0	MMTXAK	REPSEN	0	0
		Write:								
		Reset:	0	0	0	0	0	0	0	0
\$006D	MMIIC Status Register (MMSR)	Read:	MMRXIF	MMTXIF	MMATCH	MMSRW	MMRXAK	0	MMTXBE	MMRXBF
		Write:	0	0						
		Reset:	0	0	0	0	1	0	1	0
\$006E	MMIIC Data Transmit Register (MMDTR)	Read:	MMTD7	MMTD6	MMTD5	MMTD4	MMTD3	MMTD2	MMTD1	MMTD0
		Write:								
		Reset:	1	1	1	1	1	1	1	1
\$006F	MMIIC Data Receive Register (MMDRR)	Read:	MMRD7	MMRD6	MMRD5	MMRD4	MMRD3	MMRD2	MMRD1	MMRD0
		Write:								
		Reset:	0	0	0	0	0	0	0	0
\$0070 to \$007F	Reserved	Read:								
		Write:	R	R	R	R	R	R	R	R
		Reset:								

U = Unaffected      X = Indeterminate      [Grey Box] = Unimplemented      [R Box] = Reserved

Figure 2-2. Control, Status, and Data Registers (Sheet 11 of 13)

Addr.	Register Name	Bit 7	6	5	4	3	2	1	Bit 0	
\$FE00	SIM Break Status Register (SBSR)	Read:	R	R	R	R	R	SBSW	R	
		Write:						Note		
		Reset:								0
Note: Writing a logic 0 clears SBSW.										
\$FE01	SIM Reset Status Register (SRSR)	Read:	POR	PIN	COP	ILOP	ILAD	0	LVI	0
		Write:								
		POR:	1	0	0	0	0	0	0	0
\$FE02	Reserved	Read:	R	R	R	R	R	R	R	
		Write:								
		Reset:								
\$FE03	SIM Break Flag Control Register (SBFCR)	Read:	BCFE	R	R	R	R	R	R	
		Write:								
		Reset:	0							
\$FE04	Interrupt Status Register 1 (INT1)	Read:	IF6	IF5	IF4	IF3	IF2	IF1	0	0
		Write:	R	R	R	R	R	R	R	R
		Reset:	0	0	0	0	0	0	0	0
\$FE05	Interrupt Status Register 2 (INT2)	Read:	IF14	IF13	IF12	IF11	IF10	IF9	IF8	IF7
		Write:	R	R	R	R	R	R	R	R
		Reset:	0	0	0	0	0	0	0	0
\$FE06	Interrupt Status Register 3 (INT3)	Read:	0	0	0	0	IF18	IF17	IF16	IF15
		Write:	R	R	R	R	R	R	R	R
		Reset:	0	0	0	0	0	0	0	0
\$FE07	Reserved	Read:	R	R	R	R	R	R	R	
		Write:								
		Reset:								
\$FE08	FLASH Control Register (FLCR)	Read:	0	0	0	0	HVEN	MASS	ERASE	PGM
		Write:								
		Reset:	0	0	0	0	0	0	0	0

U = Unaffected      X = Indeterminate       = Unimplemented      R = Reserved

**Figure 2-2. Control, Status, and Data Registers (Sheet 12 of 13)**

Memory Map


Addr.	Register Name	Bit 7	6	5	4	3	2	1	Bit 0	
\$FE09	Reserved	Read:	R	R	R	R	R	R	R	
		Write:	R	R	R	R	R	R	R	
		Reset:								
\$FE0A	Reserved	Read:	R	R	R	R	R	R	R	
		Write:	R	R	R	R	R	R	R	
		Reset:								
\$FE0B	Reserved	Read:	R	R	R	R	R	R	R	
		Write:	R	R	R	R	R	R	R	
		Reset:								
\$FE0C	Break Address Register High (BRKH)	Read:	Bit 15	14	13	12	11	10	9	Bit 8
		Write:								
		Reset:	0	0	0	0	0	0	0	0
\$FE0D	Break Address Register Low (BRKL)	Read:	Bit 7	6	5	4	3	2	1	Bit 0
		Write:								
		Reset:	0	0	0	0	0	0	0	0
\$FE0E	Break Status and Control Register (BRKSCR)	Read:	BRKE	BRKA	0	0	0	0	0	0
		Write:								
		Reset:	0	0	0	0	0	0	0	0
\$FE0F	Low-Voltage Inhibit Status Register (LVISR)	Read:	LVIOUT	LVIIIE	LVIIF	0	0	0	0	0
		Write:				LVIACK				
		Reset:	0	0	0	0	0	0	0	0
\$FFCF	FLASH Block Protect Register (FLBPR) <sup>#</sup>	Read:	BPR7	BPR6	BPR5	BPR4	BPR3	BPR2	BPR1	BPR0
		Write:								
		Reset:	Unaffected by reset; \$FF when blank							
<sup>#</sup> Non-volatile FLASH register; write by programming.										
\$FFFF	COP Control Register (COPCTL)	Read:	Low byte of reset vector							
		Write:	Writing clears COP counter (any value)							
		Reset:	Unaffected by reset							

U = Unaffected      X = Indeterminate      [ ] = Unimplemented      [ R ] = Reserved

Figure 2-2. Control, Status, and Data Registers (Sheet 13 of 13)



**Table 2-1. Vector Addresses**

Priority	INT Flag	Address	Vector
Lowest  Highest	IF18	\$FFD8	Real Time Clock
		\$FFD9	
	IF17	\$FFDA	ADC Conversion Complete
		\$FFDB	
	IF16	\$FFDC	Keyboard
		\$FFDD	
	IF15	\$FFDE	MMIIC
		\$FFDF	
	IF14	\$FFE0	SCI Transmit
		\$FFE1	
	IF13	\$FFE2	SCI Receive
		\$FFE3	
	IF12	\$FFE4	SCI Error
		\$FFE5	
	IF11	\$FFE6	SPI Receive
		\$FFE7	
	IF10	\$FFE8	SPI Transmit
		\$FFE9	
	IF9	\$FFEA	TIM2 Overflow
		\$FFEB	
	IF8	\$FFEC	TIM2 Channel 1
		\$FFED	
	IF7	\$FFEE	TIM2 Channel 0
		\$FFEF	
	IF6	\$FFF0	TIM1 Overflow
		\$FFF1	
	IF5	\$FFF2	TIM1 Channel 1
		\$FFF3	
	IF4	\$FFF4	TIM1 Channel 0
		\$FFF5	
IF3	\$FFF6	PLL	
	\$FFF7		
IF2	\$FFF8	LVI	
	\$FFF9		
IF1	\$FFFA	IRQ Vector (High)	
	\$FFFB	IRQ Vector (Low)	
—	\$FFFC	SWI Vector (High)	
	\$FFFD	SWI Vector (Low)	
—	\$FFFE	Reset Vector (High)	
	\$FFFF	Reset Vector (Low)	



## Section 3. Random-Access Memory (RAM)

### 3.1 Contents

3.2	Introduction . . . . .	67
3.3	Functional Description . . . . .	67

### 3.2 Introduction

This section describes the 768 bytes of RAM (random-access memory).

### 3.3 Functional Description

Addresses \$0080 through \$037F are RAM locations. The location of the stack RAM is programmable. The 16-bit stack pointer allows the stack to be anywhere in the 64K-byte memory space.

**NOTE:** *For correct operation, the stack pointer must point only to RAM locations.*

Within page zero are 128 bytes of RAM. Because the location of the stack RAM is programmable, all page zero RAM locations can be used for I/O control and user data or code. When the stack pointer is moved from its reset location at \$00FF out of page zero, direct addressing mode instructions can efficiently access all page zero RAM locations. Page zero RAM, therefore, provides ideal locations for frequently accessed global variables.

Before processing an interrupt, the CPU uses five bytes of the stack to save the contents of the CPU registers.

**NOTE:** *For M6805 compatibility, the H register is not stacked.*

During a subroutine call, the CPU uses two bytes of the stack to store the return address. The stack pointer decrements during pushes and increments during pulls.

**NOTE:** *Be careful when using nested subroutines. The CPU may overwrite data in the RAM during a subroutine or during the interrupt stacking operation.*

## Section 4. FLASH Memory (FLASH)

### 4.1 Contents

4.2	Introduction . . . . .	69
4.3	Functional Description . . . . .	70
4.4	FLASH Control Register . . . . .	71
4.5	FLASH Page Erase Operation . . . . .	72
4.6	FLASH Mass Erase Operation . . . . .	73
4.7	FLASH Program Operation . . . . .	74
4.8	FLASH Block Protection . . . . .	76
4.8.1	FLASH Block Protect Register . . . . .	77

### 4.2 Introduction

This section describes the operation of the embedded FLASH memory. This memory can be read, programmed, and erased from a single external supply. The program and erase operations are enabled through the use of an internal charge pump.

**FLASH Memory (FLASH)**

Addr.	Register Name	Bit 7	6	5	4	3	2	1	Bit 0	
\$FE08	FLASH Control Register (FLCR)	Read:	0	0	0	0	HVEN	MASS	ERASE	PGM
		Write:								
		Reset:	0	0	0	0	0	0	0	0
\$FFCF	FLASH Block Protect Register (FLBPR) <sup>#</sup>	Read:	BPR7	BPR6	BPR5	BPR4	BPR3	BPR2	BPR1	BPR0
		Write:								
		Reset:	Unaffected by reset; \$FF when blank							

# Non-volatile FLASH register; write by programming.

= Unimplemented

**Figure 4-1. FLASH I/O Register Summary**

**4.3 Functional Description**

The FLASH memory consists of an array of 24,576 bytes for user memory plus a block of 48 bytes for user interrupt vectors. *An erased bit reads as logic 1 and a programmed bit reads as a logic 0.* The FLASH memory page size is defined as 128 bytes, and is the minimum size that can be erased in a page erase operation. Program and erase operations are facilitated through control bits in FLASH control register (FLCR). The address ranges for the FLASH memory are:

- \$9000–\$EFFF; user memory, 24,576 bytes
- \$FFD0–\$FFFF; user interrupt vectors, 48 bytes

Programming tools are available from Motorola. Contact your local Motorola representative for more information.

**NOTE:** *A security feature prevents viewing of the FLASH contents.<sup>1</sup>*

1. No security feature is absolutely secure. However, Motorola’s strategy is to make reading or copying the FLASH difficult for unauthorized users.

### 4.4 FLASH Control Register

The FLASH control register (FLCR) controls FLASH program and erase operations.

Address: \$FE08

	Bit 7	6	5	4	3	2	1	Bit 0
Read:	0	0	0	0	HVEN	MASS	ERASE	PGM
Write:								
Reset:	0	0	0	0	0	0	0	0

**Figure 4-2. FLASH Control Register (FLCR)**

#### HVEN — High Voltage Enable Bit

This read/write bit enables the charge pump to drive high voltages for program and erase operations in the array. HVEN can only be set if either PGM = 1 or ERASE = 1 and the proper sequence for program or erase is followed.

- 1 = High voltage enabled to array and charge pump on
- 0 = High voltage disabled to array and charge pump off

#### MASS — Mass Erase Control Bit

This read/write bit configures the memory for mass erase operation or block erase operation when the ERASE bit is set.

- 1 = Mass Erase operation selected
- 0 = Block Erase operation selected

#### ERASE — Erase Control Bit

This read/write bit configures the memory for erase operation. ERASE is interlocked with the PGM bit such that both bits cannot be equal to 1 or set to 1 at the same time.

- 1 = Erase operation selected
- 0 = Erase operation not selected

#### PGM — Program Control Bit

This read/write bit configures the memory for program operation. PGM is interlocked with the ERASE bit such that both bits cannot be equal to 1 or set to 1 at the same time.

- 1 = Program operation selected
- 0 = Program operation not selected

## 4.5 FLASH Page Erase Operation

Use the following procedure to erase a page of FLASH memory. A page consists of 128 consecutive bytes starting from addresses \$xx00 or \$xx80. The 48-byte user interrupt vectors area also forms a page. *The 48-byte user interrupt vectors cannot be erased by the page erase operation because of security reasons. Mass erase is required to erase this page.*

1. Set the ERASE bit and clear the MASS bit in the FLASH control register.
2. Read the FLASH block protect register.
3. Write any data to any FLASH address within the page address range desired.
4. Wait for a time,  $t_{nvs}$  (min. 10  $\mu$ s).
5. Set the HVEN bit.
6. Wait for a time,  $t_{erase}$  (1 ms).
7. Clear the ERASE bit.
8. Wait for a time,  $t_{nvh}$  (5  $\mu$ s).
9. Clear the HVEN bit.
10. After time,  $t_{rcv}$  (1  $\mu$ s), the memory can be accessed in read mode again.

**NOTE:** *Programming and erasing of FLASH locations cannot be performed by code being executed from the FLASH memory; the code must be executed from RAM. While these operations must be performed in the order as shown, but other unrelated operations may occur between the steps.*



## 4.6 FLASH Mass Erase Operation

Use the following procedure to erase the entire FLASH memory:

1. Set both the ERASE bit and the MASS bit in the FLASH control register.
2. Read the FLASH block protect register.
3. Write any data to any FLASH address within the FLASH memory address range.
4. Wait for a time,  $t_{nvs}$  (10  $\mu$ s).
5. Set the HVEN bit.
6. Wait for a time  $t_{merase}$  (4 ms).
7. Clear the ERASE bit.
8. Wait for a time,  $t_{nvh1}$  (100  $\mu$ s).
9. Clear the HVEN bit.
10. After time,  $t_{rcv}$  (1  $\mu$ s), the memory can be accessed again in read mode.

**NOTE:** *Programming and erasing of FLASH locations cannot be performed by code being executed from the FLASH memory; the code must be executed from RAM. While these operations must be performed in the order as shown, but other unrelated operations may occur between the steps.*

## 4.7 FLASH Program Operation

Programming of the FLASH memory is done on a row basis. A row consists of 64 consecutive bytes starting from addresses \$xx00, \$xx40, \$xx80, or \$xxC0. Use the following procedure to program a row of FLASH memory. (Figure 4-3 shows a flowchart of the programming algorithm.)

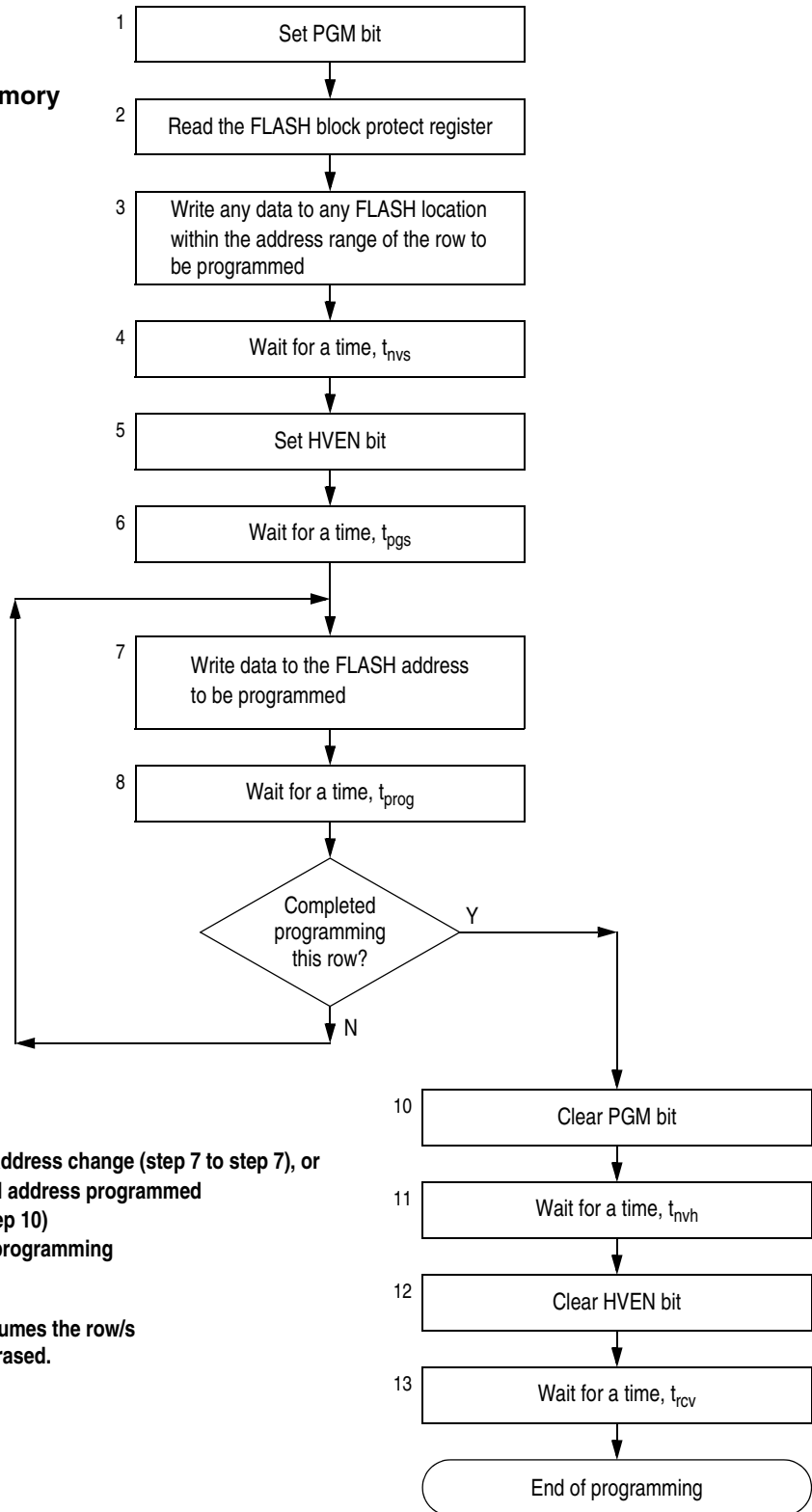
1. Set the PGM bit. This configures the memory for program operation and enables the latching of address and data for programming.
2. Read the FLASH block protect register.
3. Write any data to any FLASH address within the row address range desired.
4. Wait for a time,  $t_{nvs}$  (10  $\mu$ s).
5. Set the HVEN bit.
6. Wait for a time,  $t_{pgs}$  (5  $\mu$ s).
7. Write data to the FLASH address to be programmed.
8. Wait for time,  $t_{prog}$  (30  $\mu$ s).
9. Repeat steps 7 and 8 until all bytes within the row are programmed.
10. Clear the PGM bit.
11. Wait for time,  $t_{nvh}$  (5  $\mu$ s).
12. Clear the HVEN bit.
13. After time,  $t_{rcv}$  (1  $\mu$ s), the memory can be accessed in read mode again.

This program sequence is repeated throughout the memory until all data is programmed.

**NOTE:** *The time between each FLASH address change (step 7 to step 7), or the time between the last FLASH addressed programmed to clearing the PGM bit (step 7 to step 10), must not exceed the maximum programming time,  $t_{prog}$  max.*

**NOTE:** *Programming and erasing of FLASH locations cannot be performed by code being executed from the FLASH memory. While these operations must be performed in the order shown, other unrelated operations may occur between the steps.*

Algorithm for programming  
a row (64 bytes) of FLASH memory



**NOTE:**

The time between each FLASH address change (step 7 to step 7), or the time between the last FLASH address programmed to clearing PGM bit (step 7 to step 10) must not exceed the maximum programming time,  $t_{prog\ max}$ .

This row program algorithm assumes the row/s to be programmed are initially erased.

Figure 4-3. FLASH Programming Flowchart

## 4.8 FLASH Block Protection

Due to the ability of the on-board charge pump to erase and program the FLASH memory in the target application, provision is made to protect pages of memory from unintentional erase or program operations due to system malfunction. This protection is done by use of a FLASH block protect register (FLBPR). The FLBPR determines the range of the FLASH memory which is to be protected. The range of the protected area starts from a location defined by FLBPR and ends to the bottom of the FLASH memory (\$FFFF). When the memory is protected, the HVEN bit cannot be set in either erase or program operations.

**NOTE:** *The 48 bytes of user interrupt vectors are always protected, regardless of the value in the FLASH block protect register. A mass erase is required to erase the vectors.*

When the FLBPR is program with \$20, the entire memory is protected from being programmed and erased. When the FLBPR is erased (\$FF), the entire memory is accessible for program and erase.

Once the FLBPR is programmed with a value other than \$FF, the FLBPR itself is protected. It can only be erased using a mass erase operation.

**NOTE:** *In performing a program or erase operation, the FLASH block protect register must be read after setting the PGM or ERASE bit and before asserting the HVEN bit*

### 4.8.1 FLASH Block Protect Register

The FLASH block protect register (FLBPR) is implemented as a byte within the FLASH memory, and therefore can only be written during a programming sequence of the FLASH memory. The value in this register determines the starting location of the protected range within the FLASH memory.

Address: \$FFCF

	Bit 7	6	5	4	3	2	1	Bit 0
Read:	BPR7	BPR6	BPR5	BPR4	BPR3	BPR2	BPR1	BPR0
Write:								

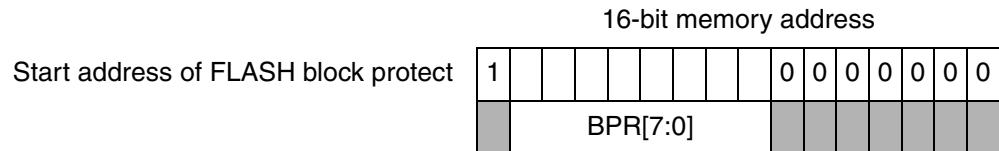
Reset: Unaffected by reset; \$FF when blank

Non-volatile FLASH register; write by programming.

**Figure 4-4. FLASH Block Protect Register (FLBPR)**

#### BPR[7:0] — FLASH Block Protect Bits

BPR[7:0] represent bits [14:7] of a 16-bit memory address. Bits [15:14] are logic 1's and bits [6:0] are logic 0's.



The resultant 16-bit address is used for specifying the start address of the FLASH memory for block protection. The FLASH is protected from this start address to the end of FLASH memory, at \$FFFF. With this mechanism, the protect start address can be \$XX00 or \$XX80 (at page boundaries — 128 bytes) within the FLASH memory.

Examples of protect start address is shown in [Table 4-1](#):

Table 4-1. FLASH Block Protect Register to Physical Address

BPR[7:0]	Start Address of Protection Range <sup>(1)</sup>
\$00 to \$1F	The entire FLASH memory is <b>NOT</b> protected. <sup>(2)</sup>
\$20	\$9000 (1001 0000 0000 0000) The entire FLASH memory is protected.
\$21	\$9080 (1001 0000 1000 0000)
\$22	\$9100 (1001 0001 0000 0000)
\$23	\$9180 (1001 0001 1000 0000)
\$24	\$9200 (1001 0010 0000 0000)
and so on...	
\$DE	\$EF00 (1110 1111 0000 0000)
\$DF	\$EF80 (1110 1111 1000 0000)
\$E0 to \$FF	The entire FLASH memory is <b>NOT</b> protected. <sup>(2)</sup>

**Notes:**

1. The end address of the protected range is always \$FFFF.
2. Except the 48-byte user vectors, which is always protected.

## Section 5. Configuration Registers (CONFIG)

### 5.1 Contents

5.2	Introduction . . . . .	79
5.3	Functional Description . . . . .	80
5.4	Configuration Register 1 (CONFIG1) . . . . .	81
5.5	Configuration Register 2 (CONFIG2) . . . . .	82

### 5.2 Introduction

This section describes the configuration registers, CONFIG1 and CONFIG2. The configuration registers enable or disable these options:

- Computer operating properly module (COP)
- COP timeout period ( $2^{18} - 2^4$  or  $2^{13} - 2^4$  ICLK cycles)
- Low-voltage inhibit (LVI) module power
- LVI module reset
- LVI module in stop mode
- LVI module voltage trip point selection
- STOP instruction
- Stop mode recovery time (32 ICLK cycles or 4096 ICLK cycles)
- Oscillator during stop mode
- LCD frontplanes FP19–FP26 on port C
- LCD frontplanes FP11–FP18 on port E

Configuration Registers (CONFIG)

Addr.	Register Name	Bit 7	6	5	4	3	2	1	Bit 0	
\$001D	Configuration Register 2 (CONFIG2) <sup>†</sup>	Read:	PEE	STOP_IRCDIS	STOP_XCLKEN	DIV2CLK	PCEH	PCEL	LWISEL1	LWISEL0
		Write:								
		Reset:	0	0	0	0	0	0	0 <sup>††</sup>	1 <sup>††</sup>
\$001F	Configuration Register 1 (CONFIG1) <sup>†</sup>	Read:	COPRS	LVISTOP	LVIRSTD	LVIPWRD	0	SSREC	STOP	COPD
		Write:								
		Reset:	0	0	0	0 <sup>††</sup>	0	0	0	0

<sup>†</sup> One-time writable register after each reset.

<sup>††</sup> Reset by POR only.


 = Unimplemented

Figure 5-1. CONFIG Registers Summary

5.3 Functional Description

The configuration registers are used in the initialization of various options. Since the various options affect the operation of the MCU, it is recommended that these registers be written immediately after reset. The configuration registers are located at \$001D and \$001F. The configuration registers may be read at anytime.

**NOTE:** *The CONFIG registers are one-time writable by the user after each reset. These registers are not in the FLASH memory but are special registers containing one-time writable latches after each reset. Upon a reset, the CONFIG registers default to predetermined settings as shown in Figure 5-2 and Figure 5-3.*

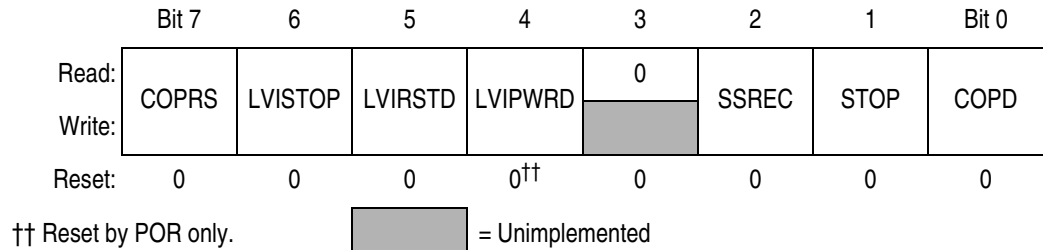
*Although the LWISEL[1:0] bits default to predetermined setting of LWISEL[1:0] = 0:1 by a POR only, these bits can still be written once after each reset other than POR.*



## 5.4 Configuration Register 1 (CONFIG1)

The CONFIG1 register can be written once after each reset.

Address: \$001F



**Figure 5-2. Configuration Register 1 (CONFIG1)**

### COPRS — COP Rate Select

COPRS selects the COP time-out period. Reset clears COPRS. (See [Section 21. Computer Operating Properly \(COP\)](#).)

1 = COP time out period =  $2^{13} - 2^4$  ICLK cycles

0 = COP time out period =  $2^{18} - 2^4$  ICLK cycles

### LVISTOP — LVI Enable in Stop Mode

When the LVIPWRD bit is clear, setting the LVISTOP bit enables the LVI to operate during stop mode. Reset clears LVISTOP. (See [Section 22. Low-Voltage Inhibit \(LVI\)](#).)

1 = LVI enabled during stop mode

0 = LVI disabled during stop mode

### LVIRSTD — LVI Reset Disable

LVIRSTD disables the reset signal from the LVI module. (See [Section 22. Low-Voltage Inhibit \(LVI\)](#).)

1 = LVI module resets disabled

0 = LVI module resets enabled

### LVIPWRD — LVI Power Disable Bit

LVIPWRD disables the LVI module. (See [Section 22. Low-Voltage Inhibit \(LVI\)](#).)

1 = LVI module power disabled

0 = LVI module power enabled

Configuration Registers (CONFIG)

SSREC — Short Stop Recovery

SSREC enables the CPU to exit stop mode with a delay of 32 ICLK cycles instead of a 4096 ICLK cycle delay.

- 1 = Stop mode recovery after 32 ICLK cycles
- 0 = Stop mode recovery after 4096 ICLK cycles

**NOTE:** *Exiting stop mode by pulling reset will result in the long stop recovery. If using an external crystal oscillator, do not set the SSREC bit.*

**NOTE:** *When the LVISTOP is enabled, the system stabilization time for power on reset and long stop recovery (both 4096 ICLK cycles) gives a delay longer than the enable time for the LVI. There is no period where the MCU is not protected from a low power condition. However, when using the short stop recovery configuration option, the 32 ICLK delay is less than the LVI's turn-on time and there exists a period in start-up where the LVI is not protecting the MCU.*

STOP — STOP Instruction Enable

STOP enables the STOP instruction.

- 1 = STOP instruction enabled
- 0 = STOP instruction treated as illegal opcode

COPD — COP Disable Bit

COPD disables the COP module. (See [Section 21. Computer Operating Properly \(COP\)](#).)

- 1 = COP module disabled
- 0 = COP module enabled

5.5 Configuration Register 2 (CONFIG2)

The CONFIG2 register can be written once after each reset.

Address: \$001D

	Bit 7	6	5	4	3	2	1	Bit 0
Read:	PEE	STOP_IRCDIS	STOP_XCLKEN	DIV2CLK	PCEH	PCEL	LVISEL1	LVISEL0
Write:								
Reset:	0	0	0	0	0	0	0 <sup>††</sup>	1 <sup>††</sup>

<sup>††</sup> Reset by POR only.

Figure 5-3. Configuration Register 2 (CONFIG2)

## PEE — Port E Enable

Setting PEE configures the PTE0/FP11–PTE7/FP18 pins for LCD frontplane driver use. Reset clears this bit.

1 = PTE0/FP11–PTE7/FP18 pins configured as LCD frontplane driver pins: FP11–FP18

0 = PTE0/FP11–PTE7/FP18 pins configured as standard I/O pins: PTE0–PTE7

## STOP\_IRCDIS — Internal RC Oscillator Stop Mode Disable

Setting STOP\_IRCDIS disables the internal RC oscillator during stop mode. When this bit is cleared, the internal RC oscillator continues to operate in stop mode. Reset clears this bit.

1 = Internal RC oscillator disabled during stop mode

0 = Internal RC oscillator enabled during stop mode

## STOP\_XCLKEN — Crystal Oscillator Stop Mode Enable

Setting STOP\_XCLKEN enables the external crystal (XTAL) oscillator to continue operating in stop mode. This is useful for driving the real time clock module to allow it to generate periodic wake up while in stop mode. When this bit is cleared, the external XTAL oscillator will be disabled during stop mode. Reset clears this bit.

1 = XTAL oscillator enabled during stop mode

0 = XTAL oscillator disabled during stop mode

## DIV2CLK — Divide-by-2 Clock Bypass

When CGMXCLK is selected to drive the system clocks (BCS=0), setting DIV2CLK allows the CGMXCLK to bypass the divide-by-2 divider in the CGM module; CGMOUT will equal CGMXCLK and bus clock will equal CGMXCLK divide-by-2.

DIV2CLK bit has no effect when the BCS=1 in the PLL control register (CGMVCLK selected and divide-by-2 always enabled). Reset clears this bit.

1 = Divide-by-2 divider bypassed;

When BSC=0, CGMOUT equals CGMXCLK

0 = Divide-by-2 divider enabled;

When BSC=0, CGMOUT equals CGMXCLK divide-by-2

PCEH — Port C Enable High Nibble

Setting PCEH configures the PTC4/FP23–PTC7/FP26 pins for LCD frontplane driver use. Reset clears this bit.

- 1 = PTC4/FP23–PTC7/FP26 pins configured as LCD frontplane driver pins: FP23–FP26
- 0 = PTC4/FP23–PTC7/FP26 pins configured as standard I/O pins: PTC4–PTC7

PCEL — Port C Enable Low Nibble

Setting PCEL configures the PTC0/FP19–PTC3/FP22 pins for LCD frontplane driver use. Reset clears this bit.

- 1 = PTC0/FP19–PTC3/FP22 pins configured as LCD frontplane driver pins: FP19–FP22
- 0 = PTC0/FP19–PTC3/FP22 pins configured as standard I/O pins: PTC0–PTC3

LVISEL[1:0] — LVI Operating Mode Selection

LVISEL[1:0] selects the voltage operating mode of the LVI module. (See [Section 22. Low-Voltage Inhibit \(LVI\)](#).) The voltage mode selected for the LVI should match the operating  $V_{DD}$ . See [Section 24. Electrical Specifications](#) for the LVI voltage trip points for each of the modes.

Table 5-1. LVI Trip Point Selection

LVISEL1	LVISEL0	Operating Mode
0	0	Reserved
0	1	3.3V <sup>(1)</sup>
1	0	5V
1	1	Reserved

Notes:

- 1. Default setting after a power-on-reset.

## Section 6. Central Processor Unit (CPU)

### 6.1 Contents

6.2	Introduction . . . . .	86
6.3	Features . . . . .	86
6.4	CPU Registers . . . . .	87
6.4.1	Accumulator . . . . .	87
6.4.2	Index Register . . . . .	88
6.4.3	Stack Pointer . . . . .	88
6.4.4	Program Counter . . . . .	89
6.4.5	Condition Code Register . . . . .	90
6.5	Arithmetic/Logic Unit (ALU) . . . . .	92
6.6	Low-Power Modes . . . . .	92
6.6.1	Wait Mode . . . . .	92
6.6.2	Stop Mode . . . . .	93
6.7	CPU During Break Interrupts . . . . .	93
6.8	Instruction Set Summary . . . . .	93
6.9	Opcode Map . . . . .	93

## 6.2 Introduction

The M68HC08 CPU (central processor unit) is an enhanced and fully object-code-compatible version of the M68HC05 CPU. The *CPU08 Reference Manual* (Motorola document order number CPU08RM/AD) contains a description of the CPU instruction set, addressing modes, and architecture.

## 6.3 Features

Feature of the CPU include:

- Object code fully upward-compatible with M68HC05 Family
- 16-bit stack pointer with stack manipulation instructions
- 16-Bit index register with X-register manipulation instructions
- 8-MHz CPU internal bus frequency
- 64-Kbyte program/data memory space
- 16 addressing modes
- Memory-to-memory data moves without using accumulator
- Fast 8-bit by 8-bit multiply and 16-bit by 8-bit divide instructions
- Enhanced binary-coded decimal (BCD) data handling
- Modular architecture with expandable internal bus definition for extension of addressing range beyond 64-Kbytes
- Low-power stop and wait modes

## 6.4 CPU Registers

Figure 6-1 shows the five CPU registers. CPU registers are not part of the memory map.

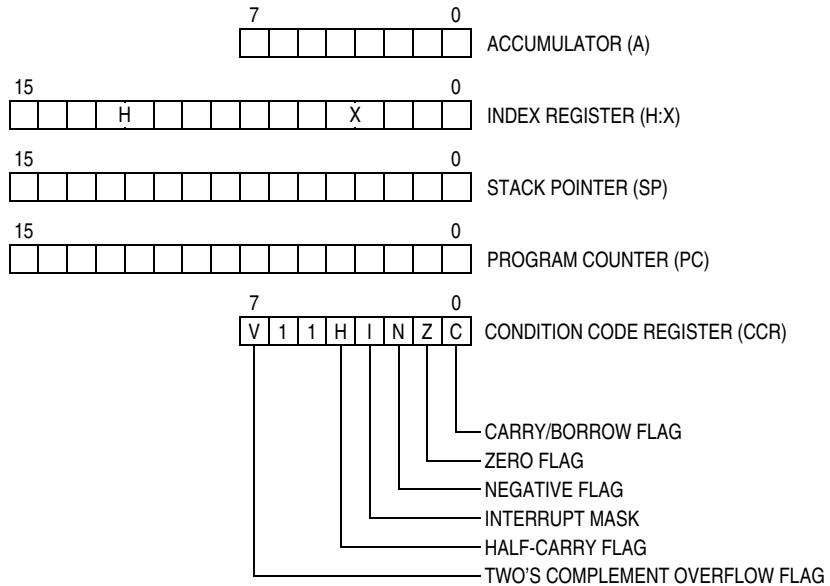


Figure 6-1. CPU Registers

### 6.4.1 Accumulator

The accumulator is a general-purpose 8-bit register. The CPU uses the accumulator to hold operands and the results of arithmetic/logic operations.

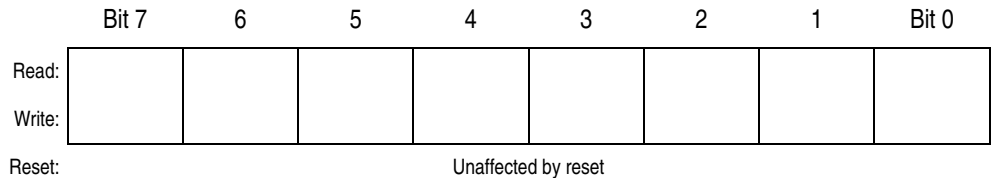


Figure 6-2. Accumulator (A)

### 6.4.2 Index Register

The 16-bit index register allows indexed addressing of a 64K-byte memory space. H is the upper byte of the index register, and X is the lower byte. H:X is the concatenated 16-bit index register.

In the indexed addressing modes, the CPU uses the contents of the index register to determine the conditional address of the operand.

The index register can serve also as a temporary data storage location.

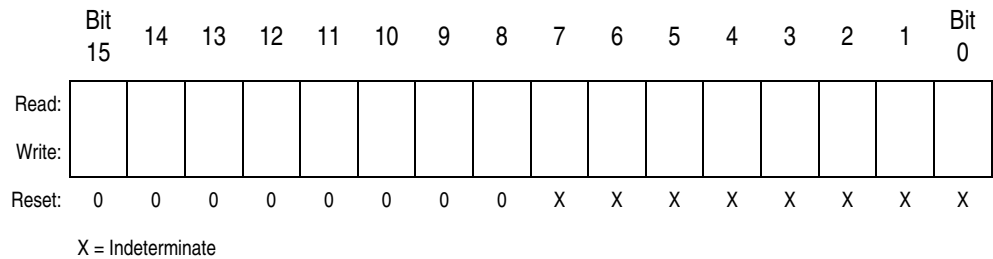


Figure 6-3. Index Register (H:X)

### 6.4.3 Stack Pointer

The stack pointer is a 16-bit register that contains the address of the next location on the stack. During a reset, the stack pointer is preset to \$00FF. The reset stack pointer (RSP) instruction sets the least significant byte to \$FF and does not affect the most significant byte. The stack pointer decrements as data is pushed onto the stack and increments as data is pulled from the stack.

In the stack pointer 8-bit offset and 16-bit offset addressing modes, the stack pointer can function as an index register to access data on the stack. The CPU uses the contents of the stack pointer to determine the conditional address of the operand.

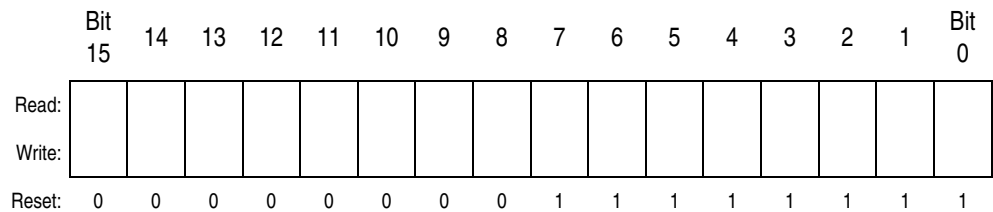


Figure 6-4. Stack Pointer (SP)



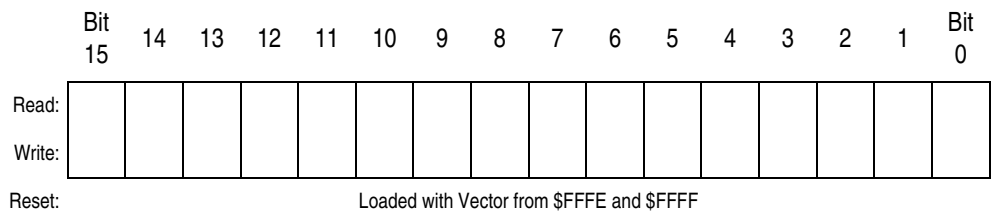
**NOTE:** *The location of the stack is arbitrary and may be relocated anywhere in RAM. Moving the SP out of page 0 (\$0000 to \$00FF) frees direct address (page 0) space. For correct operation, the stack pointer must point only to RAM locations.*

### 6.4.4 Program Counter

The program counter is a 16-bit register that contains the address of the next instruction or operand to be fetched.

Normally, the program counter automatically increments to the next sequential memory location every time an instruction or operand is fetched. Jump, branch, and interrupt operations load the program counter with an address other than that of the next sequential location.

During reset, the program counter is loaded with the reset vector address located at \$FFFE and \$FFFF. The vector address is the address of the first instruction to be executed after exiting the reset state.



**Figure 6-5. Program Counter (PC)**

6.4.5 Condition Code Register

The 8-bit condition code register contains the interrupt mask and five flags that indicate the results of the instruction just executed. Bits 6 and 5 are set permanently to logic 1. The following paragraphs describe the functions of the condition code register.

	Bit 7	6	5	4	3	2	1	Bit 0
Read:	V	1	1	H	I	N	Z	C
Write:								
Reset:	X	1	1	X	1	X	X	X

X = Indeterminate

Figure 6-6. Condition Code Register (CCR)

V — Overflow Flag

The CPU sets the overflow flag when a two's complement overflow occurs. The signed branch instructions BGT, BGE, BLE, and BLT use the overflow flag.

- 1 = Overflow
- 0 = No overflow

H — Half-Carry Flag

The CPU sets the half-carry flag when a carry occurs between accumulator bits 3 and 4 during an add-without-carry (ADD) or add-with-carry (ADC) operation. The half-carry flag is required for binary-coded decimal (BCD) arithmetic operations. The DAA instruction uses the states of the H and C flags to determine the appropriate correction factor.

- 1 = Carry between bits 3 and 4
- 0 = No carry between bits 3 and 4

## I — Interrupt Mask

When the interrupt mask is set, all maskable CPU interrupts are disabled. CPU interrupts are enabled when the interrupt mask is cleared. When a CPU interrupt occurs, the interrupt mask is set automatically after the CPU registers are saved on the stack, but before the interrupt vector is fetched.

1 = Interrupts disabled

0 = Interrupts enabled

**NOTE:** *To maintain M6805 Family compatibility, the upper byte of the index register (H) is not stacked automatically. If the interrupt service routine modifies H, then the user must stack and unstack H using the PSHH and PULH instructions.*

After the I bit is cleared, the highest-priority interrupt request is serviced first.

A return-from-interrupt (RTI) instruction pulls the CPU registers from the stack and restores the interrupt mask from the stack. After any reset, the interrupt mask is set and can be cleared only by the clear interrupt mask software instruction (CLI).

## N — Negative Flag

The CPU sets the negative flag when an arithmetic operation, logic operation, or data manipulation produces a negative result, setting bit 7 of the result.

1 = Negative result

0 = Non-negative result

## Z — Zero Flag

The CPU sets the zero flag when an arithmetic operation, logic operation, or data manipulation produces a result of \$00.

1 = Zero result

0 = Non-zero result

**C — Carry/Borrow Flag**

The CPU sets the carry/borrow flag when an addition operation produces a carry out of bit 7 of the accumulator or when a subtraction operation requires a borrow. Some instructions — such as bit test and branch, shift, and rotate — also clear or set the carry/borrow flag.

1 = Carry out of bit 7

0 = No carry out of bit 7

**6.5 Arithmetic/Logic Unit (ALU)**

The ALU performs the arithmetic and logic operations defined by the instruction set.

Refer to the *CPU08 Reference Manual* (Motorola document order number CPU08RM/AD) for a description of the instructions and addressing modes and more detail about the architecture of the CPU.

**6.6 Low-Power Modes**

The WAIT and STOP instructions put the MCU in low power-consumption standby modes.

**6.6.1 Wait Mode**

The WAIT instruction:

- Clears the interrupt mask (I bit) in the condition code register, enabling interrupts. After exit from wait mode by interrupt, the I bit remains clear. After exit by reset, the I bit is set.
- Disables the CPU clock.

## 6.6.2 Stop Mode

The STOP instruction:

- Clears the interrupt mask (I bit) in the condition code register, enabling external interrupts. After exit from stop mode by external interrupt, the I bit remains clear. After exit by reset, the I bit is set.
- Disables the CPU clock.

After exiting stop mode, the CPU clock begins running after the oscillator stabilization delay.

## 6.7 CPU During Break Interrupts

If the break module is enabled, a break interrupt causes the CPU to execute the software interrupt instruction (SWI) at the completion of the current CPU instruction. (See [Section 23. Break Module \(BRK\)](#).) The program counter vectors to \$FFFC–\$FFFD (\$FEFC–\$FEFD in monitor mode).

A return-from-interrupt instruction (RTI) in the break routine ends the break interrupt and returns the MCU to normal operation if the break interrupt has been deasserted.

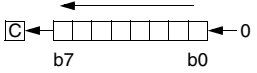
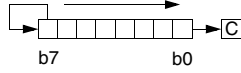
## 6.8 Instruction Set Summary

[Table 6-1](#) provides a summary of the M68HC08 instruction set.

## 6.9 Opcode Map

The opcode map is provided in [Table 6-2](#).

Table 6-1. Instruction Set Summary (Sheet 1 of 8)

Source Form	Operation	Description	Effect on CCR						Address Mode	Opcode	Operand	Cycles
			V	H	I	N	Z	C				
ADC #opr ADC opr ADC opr ADC opr,X ADC opr,X ADC ,X ADC opr,SP ADC opr,SP	Add with Carry	$A \leftarrow (A) + (M) + (C)$	↕	↕	–	↕	↕	↕	IMM DIR EXT IX2 IX1 IX SP1 SP2	A9 B9 C9 D9 E9 F9 9EE9 9ED9	ii dd hh ll ee ff ff ff ff ff ee ff	2 3 4 4 3 2 4 5
ADD #opr ADD opr ADD opr ADD opr,X ADD opr,X ADD ,X ADD opr,SP ADD opr,SP	Add without Carry	$A \leftarrow (A) + (M)$	↕	↕	–	↕	↕	↕	IMM DIR EXT IX2 IX1 IX SP1 SP2	AB BB CB DB EB FB 9EEB 9EDB	ii dd hh ll ee ff ff ff ff ee ff	2 3 4 4 3 2 4 5
AIS #opr	Add Immediate Value (Signed) to SP	$SP \leftarrow (SP) + (16 \ll M)$	–	–	–	–	–	–	IMM	A7	ii	2
AIX #opr	Add Immediate Value (Signed) to H:X	$H:X \leftarrow (H:X) + (16 \ll M)$	–	–	–	–	–	–	IMM	AF	ii	2
AND #opr AND opr AND opr AND opr,X AND opr,X AND ,X AND opr,SP AND opr,SP	Logical AND	$A \leftarrow (A) \& (M)$	0	–	–	↕	↕	–	IMM DIR EXT IX2 IX1 IX SP1 SP2	A4 B4 C4 D4 E4 F4 9EE4 9ED4	ii dd hh ll ee ff ff ff ff ee ff	2 3 4 4 3 2 4 5
ASL opr ASLA ASLX ASL opr,X ASL ,X ASL opr,SP	Arithmetic Shift Left (Same as LSL)		↕	–	–	↕	↕	↕	DIR INH INH IX1 IX SP1	38 48 58 68 78 9E68	dd 1 1 ff 3 ff	4 1 1 4 3 5
ASR opr ASRA ASRX ASR opr,X ASR opr,X ASR opr,SP	Arithmetic Shift Right		↕	–	–	↕	↕	↕	DIR INH INH IX1 IX SP1	37 47 57 67 77 9E67	dd 1 1 ff 3 ff	4 1 1 4 3 5
BCC rel	Branch if Carry Bit Clear	$PC \leftarrow (PC) + 2 + rel \text{ ? } (C) = 0$	–	–	–	–	–	–	REL	24	rr	3
BCLR n, opr	Clear Bit n in M	$M_n \leftarrow 0$	–	–	–	–	–	–	DIR (b0) DIR (b1) DIR (b2) DIR (b3) DIR (b4) DIR (b5) DIR (b6) DIR (b7)	11 13 15 17 19 1B 1D 1F	dd dd dd dd dd dd dd dd	4 4 4 4 4 4 4 4

### Table 6-1. Instruction Set Summary (Sheet 2 of 8)

Source Form	Operation	Description	Effect on CCR						Address Mode	Opcode	Operand	Cycles
			V	H	I	N	Z	C				
BCS <i>rel</i>	Branch if Carry Bit Set (Same as BLO)	$PC \leftarrow (PC) + 2 + rel ? (C) = 1$	-	-	-	-	-	-	REL	25	rr	3
BEQ <i>rel</i>	Branch if Equal	$PC \leftarrow (PC) + 2 + rel ? (Z) = 1$	-	-	-	-	-	-	REL	27	rr	3
BGE <i>opr</i>	Branch if Greater Than or Equal To (Signed Operands)	$PC \leftarrow (PC) + 2 + rel ? (N \oplus V) = 0$	-	-	-	-	-	-	REL	90	rr	3
BGT <i>opr</i>	Branch if Greater Than (Signed Operands)	$PC \leftarrow (PC) + 2 + rel ? (Z) \mid (N \oplus V) = 0$	-	-	-	-	-	-	REL	92	rr	3
BHCC <i>rel</i>	Branch if Half Carry Bit Clear	$PC \leftarrow (PC) + 2 + rel ? (H) = 0$	-	-	-	-	-	-	REL	28	rr	3
BHCS <i>rel</i>	Branch if Half Carry Bit Set	$PC \leftarrow (PC) + 2 + rel ? (H) = 1$	-	-	-	-	-	-	REL	29	rr	3
BHI <i>rel</i>	Branch if Higher	$PC \leftarrow (PC) + 2 + rel ? (C) \mid (Z) = 0$	-	-	-	-	-	-	REL	22	rr	3
BHS <i>rel</i>	Branch if Higher or Same (Same as BCC)	$PC \leftarrow (PC) + 2 + rel ? (C) = 0$	-	-	-	-	-	-	REL	24	rr	3
BIH <i>rel</i>	Branch if $\overline{IRQ}$ Pin High	$PC \leftarrow (PC) + 2 + rel ? \overline{IRQ} = 1$	-	-	-	-	-	-	REL	2F	rr	3
BIL <i>rel</i>	Branch if $\overline{IRQ}$ Pin Low	$PC \leftarrow (PC) + 2 + rel ? \overline{IRQ} = 0$	-	-	-	-	-	-	REL	2E	rr	3
BIT # <i>opr</i> BIT <i>opr</i> BIT <i>opr</i> ,X BIT <i>opr</i> ,X BIT ,X BIT <i>opr</i> ,SP BIT <i>opr</i> ,SP	Bit Test	(A) & (M)	0	-	-	⚡	⚡	-	IMM DIR EXT IX2 IX1 IX SP1 SP2	A5 B5 C5 D5 E5 F5 9EE5 9ED5	ii dd hh ll ee ff ff ff ff ee ff	2 3 4 4 3 2 4 5
BLE <i>opr</i>	Branch if Less Than or Equal To (Signed Operands)	$PC \leftarrow (PC) + 2 + rel ? (Z) \mid (N \oplus V) = 1$	-	-	-	-	-	-	REL	93	rr	3
BLO <i>rel</i>	Branch if Lower (Same as BCS)	$PC \leftarrow (PC) + 2 + rel ? (C) = 1$	-	-	-	-	-	-	REL	25	rr	3
BLS <i>rel</i>	Branch if Lower or Same	$PC \leftarrow (PC) + 2 + rel ? (C) \mid (Z) = 1$	-	-	-	-	-	-	REL	23	rr	3
BLT <i>opr</i>	Branch if Less Than (Signed Operands)	$PC \leftarrow (PC) + 2 + rel ? (N \oplus V) = 1$	-	-	-	-	-	-	REL	91	rr	3
BMC <i>rel</i>	Branch if Interrupt Mask Clear	$PC \leftarrow (PC) + 2 + rel ? (I) = 0$	-	-	-	-	-	-	REL	2C	rr	3
BMI <i>rel</i>	Branch if Minus	$PC \leftarrow (PC) + 2 + rel ? (N) = 1$	-	-	-	-	-	-	REL	2B	rr	3
BMS <i>rel</i>	Branch if Interrupt Mask Set	$PC \leftarrow (PC) + 2 + rel ? (I) = 1$	-	-	-	-	-	-	REL	2D	rr	3
BNE <i>rel</i>	Branch if Not Equal	$PC \leftarrow (PC) + 2 + rel ? (Z) = 0$	-	-	-	-	-	-	REL	26	rr	3
BPL <i>rel</i>	Branch if Plus	$PC \leftarrow (PC) + 2 + rel ? (N) = 0$	-	-	-	-	-	-	REL	2A	rr	3
BRA <i>rel</i>	Branch Always	$PC \leftarrow (PC) + 2 + rel$	-	-	-	-	-	-	REL	20	rr	3

Table 6-1. Instruction Set Summary (Sheet 3 of 8)

Source Form	Operation	Description	Effect on CCR						Address Mode	Opcode	Operand	Cycles
			V	H	I	N	Z	C				
BRCLR <i>n,opr,rel</i>	Branch if Bit <i>n</i> in M Clear	$PC \leftarrow (PC) + 3 + rel ? (Mn) = 0$	-	-	-	-	-	↓	DIR (b0) DIR (b1) DIR (b2) DIR (b3) DIR (b4) DIR (b5) DIR (b6) DIR (b7)	01 03 05 07 09 0B 0D 0F	dd rr dd rr dd rr dd rr dd rr dd rr dd rr dd rr	5 5 5 5 5 5 5 5
BRN <i>rel</i>	Branch Never	$PC \leftarrow (PC) + 2$	-	-	-	-	-	-	REL	21	rr	3
BRSET <i>n,opr,rel</i>	Branch if Bit <i>n</i> in M Set	$PC \leftarrow (PC) + 3 + rel ? (Mn) = 1$	-	-	-	-	-	↓	DIR (b0) DIR (b1) DIR (b2) DIR (b3) DIR (b4) DIR (b5) DIR (b6) DIR (b7)	00 02 04 06 08 0A 0C 0E	dd rr dd rr dd rr dd rr dd rr dd rr dd rr dd rr	5 5 5 5 5 5 5 5
BSET <i>n,opr</i>	Set Bit <i>n</i> in M	$Mn \leftarrow 1$	-	-	-	-	-	-	DIR (b0) DIR (b1) DIR (b2) DIR (b3) DIR (b4) DIR (b5) DIR (b6) DIR (b7)	10 12 14 16 18 1A 1C 1E	dd dd dd dd dd dd dd dd	4 4 4 4 4 4 4 4
BSR <i>rel</i>	Branch to Subroutine	$PC \leftarrow (PC) + 2$ ; push (PCL) $SP \leftarrow (SP) - 1$ ; push (PCH) $SP \leftarrow (SP) - 1$ $PC \leftarrow (PC) + rel$	-	-	-	-	-	-	REL	AD	rr	4
CBEQ <i>opr,rel</i> CBEQA # <i>opr,rel</i> CBEQX # <i>opr,rel</i> CBEQ <i>opr,X+,rel</i> CBEQ <i>X+,rel</i> CBEQ <i>opr,SP,rel</i>	Compare and Branch if Equal	$PC \leftarrow (PC) + 3 + rel ? (A) - (M) = \$00$ $PC \leftarrow (PC) + 3 + rel ? (A) - (M) = \$00$ $PC \leftarrow (PC) + 3 + rel ? (X) - (M) = \$00$ $PC \leftarrow (PC) + 3 + rel ? (A) - (M) = \$00$ $PC \leftarrow (PC) + 2 + rel ? (A) - (M) = \$00$ $PC \leftarrow (PC) + 4 + rel ? (A) - (M) = \$00$	-	-	-	-	-	-	DIR IMM IMM IX1+ IX+ SP1	31 41 51 61 71 9E61	dd rr ii rr ii rr ff rr rr ff rr	5 4 4 5 4 6
CLC	Clear Carry Bit	$C \leftarrow 0$	-	-	-	-	-	0	INH	98		1
CLI	Clear Interrupt Mask	$I \leftarrow 0$	-	-	0	-	-	-	INH	9A		2
CLR <i>opr</i> CLRA CLR X CLR H CLR <i>opr,X</i> CLR ,X CLR <i>opr,SP</i>	Clear	$M \leftarrow \$00$ $A \leftarrow \$00$ $X \leftarrow \$00$ $H \leftarrow \$00$ $M \leftarrow \$00$ $M \leftarrow \$00$ $M \leftarrow \$00$	0	-	-	0	1	-	DIR INH INH INH IX1 IX SP1	3F 4F 5F 8C 6F 7F 9E6F	dd    ff  ff	3 1 1 1 3 2 4



Table 6-1. Instruction Set Summary (Sheet 4 of 8)

Source Form	Operation	Description	Effect on CCR						Address Mode	Opcode	Operand	Cycles
			V	H	I	N	Z	C				
CMP #opr CMP opr CMP opr CMP opr,X CMP opr,X CMP ,X CMP opr,SP CMP opr,SP	Compare A with M	(A) – (M)	↓	–	–	↓	↓	↓	IMM DIR EXT IX2 IX1 IX SP1 SP2	A1 B1 C1 D1 E1 F1 9EE1 9ED1	ii dd hh ll ee ff ff ff ff ff ee ff	2 3 4 4 3 2 4 5
COM opr COMA COMX COM opr,X COM ,X COM opr,SP	Complement (One's Complement)	$M \leftarrow (\overline{M}) = \$FF - (M)$ $A \leftarrow (\overline{A}) = \$FF - (M)$ $X \leftarrow (\overline{X}) = \$FF - (M)$ $M \leftarrow (\overline{M}) = \$FF - (M)$ $M \leftarrow (\overline{M}) = \$FF - (M)$ $M \leftarrow (\overline{M}) = \$FF - (M)$	0	–	–	↓	↓	1	DIR INH INH IX1 IX SP1	33 43 53 63 73 9E63	dd ff ff ff	4 1 1 4 3 5
CPHX #opr CPHX opr	Compare H:X with M	(H:X) – (M:M + 1)	↓	–	–	↓	↓	↓	IMM DIR	65 75	ii ii+1 dd	3 4
CPX #opr CPX opr CPX opr CPX ,X CPX opr,X CPX opr,X CPX opr,SP CPX opr,SP	Compare X with M	(X) – (M)	↓	–	–	↓	↓	↓	IMM DIR EXT IX2 IX1 IX SP1 SP2	A3 B3 C3 D3 E3 F3 9EE3 9ED3	ii dd hh ll ee ff ff ff ff ee ff	2 3 4 4 3 2 4 5
DAA	Decimal Adjust A	(A) <sub>10</sub>	U	–	–	↓	↓	↓	INH	72		2
DBNZ opr,rel DBNZ rel DBNZX rel DBNZ opr,X,rel DBNZ X,rel DBNZ opr,SP,rel	Decrement and Branch if Not Zero	$A \leftarrow (A) - 1$ or $M \leftarrow (M) - 1$ or $X \leftarrow (X) - 1$ $PC \leftarrow (PC) + 3 + rel ? (result) \neq 0$ $PC \leftarrow (PC) + 2 + rel ? (result) \neq 0$ $PC \leftarrow (PC) + 2 + rel ? (result) \neq 0$ $PC \leftarrow (PC) + 3 + rel ? (result) \neq 0$ $PC \leftarrow (PC) + 2 + rel ? (result) \neq 0$ $PC \leftarrow (PC) + 4 + rel ? (result) \neq 0$	–	–	–	–	–	–	DIR INH INH IX1 IX SP1	3B 4B 5B 6B 7B 9E6B	dd rr rr rr ff rr rr ff rr	5 3 3 5 4 6
DEC opr DECA DECX DEC opr,X DEC ,X DEC opr,SP	Decrement	$M \leftarrow (M) - 1$ $A \leftarrow (A) - 1$ $X \leftarrow (X) - 1$ $M \leftarrow (M) - 1$ $M \leftarrow (M) - 1$ $M \leftarrow (M) - 1$	↓	–	–	↓	↓	–	DIR INH INH IX1 IX SP1	3A 4A 5A 6A 7A 9E6A	dd ff ff ff ff	4 1 1 4 3 5
DIV	Divide	$A \leftarrow (H:A)/(X)$ H ← Remainder	–	–	–	–	↓	↓	INH	52		7
EOR #opr EOR opr EOR opr EOR opr,X EOR opr,X EOR ,X EOR opr,SP EOR opr,SP	Exclusive OR M with A	$A \leftarrow (A \oplus M)$	0	–	–	↓	↓	–	IMM DIR EXT IX2 IX1 IX SP1 SP2	A8 B8 C8 D8 E8 F8 9EE8 9ED8	ii dd hh ll ee ff ff ff ff ee ff	2 3 4 4 3 2 4 5

Table 6-1. Instruction Set Summary (Sheet 5 of 8)

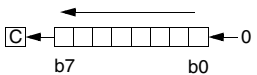
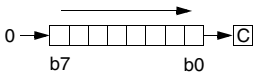
Source Form	Operation	Description	Effect on CCR						Address Mode	Opcode	Operand	Cycles
			V	H	I	N	Z	C				
INC <i>opr</i> INCA INCA INCX INC <i>opr</i> ,X INC ,X INC <i>opr</i> ,SP	Increment	M ← (M) + 1 A ← (A) + 1 X ← (X) + 1 M ← (M) + 1 M ← (M) + 1 M ← (M) + 1	⊕	-	-	⊕	⊕	-	DIR INH INH IX1 IX SP1	3C 4C 5C 6C 7C 9E6C	dd  ff ff	4 1 1 4 3 5
JMP <i>opr</i> JMP <i>opr</i> JMP <i>opr</i> ,X JMP <i>opr</i> ,X JMP ,X	Jump	PC ← Jump Address	-	-	-	-	-	-	DIR EXT IX2 IX1 IX	BC CC DC EC FC	dd hh ll ee ff ff	2 3 4 3 2
JSR <i>opr</i> JSR <i>opr</i> JSR <i>opr</i> ,X JSR <i>opr</i> ,X JSR ,X	Jump to Subroutine	PC ← (PC) + n (n = 1, 2, or 3) Push (PCL); SP ← (SP) - 1 Push (PCH); SP ← (SP) - 1 PC ← Unconditional Address	-	-	-	-	-	-	DIR EXT IX2 IX1 IX	BD CD DD ED FD	dd hh ll ee ff ff	4 5 6 5 4
LDA # <i>opr</i> LDA <i>opr</i> LDA <i>opr</i> LDA <i>opr</i> ,X LDA <i>opr</i> ,X LDA ,X LDA <i>opr</i> ,SP LDA <i>opr</i> ,SP	Load A from M	A ← (M)	0	-	-	⊕	⊕	-	IMM DIR EXT IX2 IX1 IX SP1 SP2	A6 B6 C6 D6 E6 F6 9EE6 9ED6	ii dd hh ll ee ff ff ff ff ee ff	2 3 4 4 3 2 4 5
LDHX # <i>opr</i> LDHX <i>opr</i>	Load H:X from M	H:X ← (M:M + 1)	0	-	-	⊕	⊕	-	IMM DIR	45 55	ii jj dd	3 4
LDX # <i>opr</i> LDX <i>opr</i> LDX <i>opr</i> LDX <i>opr</i> ,X LDX <i>opr</i> ,X LDX ,X LDX <i>opr</i> ,SP LDX <i>opr</i> ,SP	Load X from M	X ← (M)	0	-	-	⊕	⊕	-	IMM DIR EXT IX2 IX1 IX SP1 SP2	AE BE CE DE EE FE 9EEE 9EDE	ii dd hh ll ee ff ff ff ff ee ff	2 3 4 4 3 2 4 5
LSL <i>opr</i> LSLA LSLX LSL <i>opr</i> ,X LSL ,X LSL <i>opr</i> ,SP	Logical Shift Left (Same as ASL)		⊕	-	-	⊕	⊕	⊕	DIR INH INH IX1 IX SP1	38 48 58 68 78 9E68	dd  ff ff	4 1 1 4 3 5
LSR <i>opr</i> LSRA LSRX LSR <i>opr</i> ,X LSR ,X LSR <i>opr</i> ,SP	Logical Shift Right		⊕	-	-	0	⊕	⊕	DIR INH INH IX1 IX SP1	34 44 54 64 74 9E64	dd  ff ff	4 1 1 4 3 5

Table 6-1. Instruction Set Summary (Sheet 6 of 8)

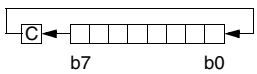
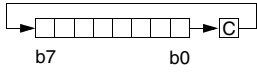
Source Form	Operation	Description	Effect on CCR						Address Mode	Opcode	Operand	Cycles
			V	H	I	N	Z	C				
MOV <i>opr,opr</i> MOV <i>opr,X+</i> MOV # <i>opr,opr</i> MOV <i>X+,opr</i>	Move	$(M)_{\text{Destination}} \leftarrow (M)_{\text{Source}}$ $H:X \leftarrow (H:X) + 1 \text{ (IX+D, DIX+)}$	0	-	-	↕	↕	-	DD DIX+ IMD IX+D	4E 5E 6E 7E	dd dd dd ii dd dd	5 4 4 4
MUL	Unsigned multiply	$X:A \leftarrow (X) \times (A)$	-	0	-	-	-	0	INH	42		5
NEG <i>opr</i> NEGA NEGX NEG <i>opr,X</i> NEG ,X NEG <i>opr,SP</i>	Negate (Two's Complement)	$M \leftarrow -(M) = \$00 - (M)$ $A \leftarrow -(A) = \$00 - (A)$ $X \leftarrow -(X) = \$00 - (X)$ $M \leftarrow -(M) = \$00 - (M)$ $M \leftarrow -(M) = \$00 - (M)$	↕	-	-	↕	↕	↕	DIR INH INH IX1 IX SP1	30 40 50 60 70 9E60	dd  ff ff	4 1 1 4 3 5
NOP	No Operation	None	-	-	-	-	-	-	INH	9D		1
NSA	Nibble Swap A	$A \leftarrow (A[3:0]:A[7:4])$	-	-	-	-	-	-	INH	62		3
ORA # <i>opr</i> ORA <i>opr</i> ORA <i>opr</i> ORA <i>opr,X</i> ORA <i>opr,X</i> ORA ,X ORA <i>opr,SP</i> ORA <i>opr,SP</i>	Inclusive OR A and M	$A \leftarrow (A)   (M)$	0	-	-	↕	↕	-	IMM DIR EXT IX2 IX1 IX SP1 SP2	AA BA CA DA EA FA 9EEA 9EDA	ii dd hh ll ee ff ff ff ff ee ff	2 3 4 4 3 2 4 5
PSHA	Push A onto Stack	Push (A); $SP \leftarrow (SP) - 1$	-	-	-	-	-	-	INH	87		2
PSHH	Push H onto Stack	Push (H); $SP \leftarrow (SP) - 1$	-	-	-	-	-	-	INH	8B		2
PSHX	Push X onto Stack	Push (X); $SP \leftarrow (SP) - 1$	-	-	-	-	-	-	INH	89		2
PULA	Pull A from Stack	$SP \leftarrow (SP + 1)$ ; Pull (A)	-	-	-	-	-	-	INH	86		2
PULH	Pull H from Stack	$SP \leftarrow (SP + 1)$ ; Pull (H)	-	-	-	-	-	-	INH	8A		2
PULX	Pull X from Stack	$SP \leftarrow (SP + 1)$ ; Pull (X)	-	-	-	-	-	-	INH	88		2
ROL <i>opr</i> ROLA ROLX ROL <i>opr,X</i> ROL ,X ROL <i>opr,SP</i>	Rotate Left through Carry		↕	-	-	↕	↕	↕	DIR INH INH IX1 IX SP1	39 49 59 69 79 9E69	dd  ff ff	4 1 1 4 3 5
ROR <i>opr</i> RORA RORX ROR <i>opr,X</i> ROR ,X ROR <i>opr,SP</i>	Rotate Right through Carry		↕	-	-	↕	↕	↕	DIR INH INH IX1 IX SP1	36 46 56 66 76 9E66	dd  ff ff	4 1 1 4 3 5
RSP	Reset Stack Pointer	$SP \leftarrow \$FF$	-	-	-	-	-	-	INH	9C		1

Table 6-1. Instruction Set Summary (Sheet 7 of 8)

Source Form	Operation	Description	Effect on CCR						Address Mode	Opcode	Operand	Cycles
			V	H	I	N	Z	C				
RTI	Return from Interrupt	SP ← (SP) + 1; Pull (CCR) SP ← (SP) + 1; Pull (A) SP ← (SP) + 1; Pull (X) SP ← (SP) + 1; Pull (PCH) SP ← (SP) + 1; Pull (PCL)	↕	↕	↕	↕	↕	↕	INH	80		7
RTS	Return from Subroutine	SP ← SP + 1; Pull (PCH) SP ← SP + 1; Pull (PCL)	-	-	-	-	-	-	INH	81		4
SBC #opr SBC opr SBC opr SBC opr,X SBC opr,X SBC ,X SBC opr,SP SBC opr,SP	Subtract with Carry	A ← (A) - (M) - (C)	↕	-	-	↕	↕	↕	IMM DIR EXT IX2 IX1 IX SP1 SP2	A2 B2 C2 D2 E2 F2 9EE2 9ED2	ii dd hh ll ee ff ff ff ff ee ff	2 3 4 4 3 2 4 5
SEC	Set Carry Bit	C ← 1	-	-	-	-	-	1	INH	99		1
SEI	Set Interrupt Mask	I ← 1	-	-	1	-	-	-	INH	9B		2
STA opr STA opr STA opr,X STA opr,X STA ,X STA opr,SP STA opr,SP	Store A in M	M ← (A)	0	-	-	↕	↕	-	DIR EXT IX2 IX1 IX SP1 SP2	B7 C7 D7 E7 F7 9EE7 9ED7	dd hh ll ee ff ff ff ff ee ff	3 4 4 3 2 4 5
STHX opr	Store H:X in M	(M:M + 1) ← (H:X)	0	-	-	↕	↕	-	DIR	35	dd	4
STOP	Enable $\overline{IRQ}$ Pin; Stop Oscillator	I ← 0; Stop Oscillator	-	-	0	-	-	-	INH	8E		1
STX opr STX opr STX opr,X STX opr,X STX ,X STX opr,SP STX opr,SP	Store X in M	M ← (X)	0	-	-	↕	↕	-	DIR EXT IX2 IX1 IX SP1 SP2	BF CF DF EF FF 9EEF 9EDF	dd hh ll ee ff ff ff ff ee ff	3 4 4 3 2 4 5
SUB #opr SUB opr SUB opr SUB opr,X SUB opr,X SUB ,X SUB opr,SP SUB opr,SP	Subtract	A ← (A) - (M)	↕	-	-	↕	↕	↕	IMM DIR EXT IX2 IX1 IX SP1 SP2	A0 B0 C0 D0 E0 F0 9EE0 9ED0	ii dd hh ll ee ff ff ff ff ee ff	2 3 4 4 3 2 4 5

Freescale Semiconductor, Inc.

**Table 6-1. Instruction Set Summary (Sheet 8 of 8)**

Source Form	Operation	Description	Effect on CCR						Address Mode	Opcode	Operand	Cycles
			V	H	I	N	Z	C				
SWI	Software Interrupt	PC ← (PC) + 1; Push (PCL) SP ← (SP) - 1; Push (PCH) SP ← (SP) - 1; Push (X) SP ← (SP) - 1; Push (A) SP ← (SP) - 1; Push (CCR) SP ← (SP) - 1; I ← 1 PCH ← Interrupt Vector High Byte PCL ← Interrupt Vector Low Byte	-	-	1	-	-	-	INH	83		9
TAP	Transfer A to CCR	CCR ← (A)	⚡	⚡	⚡	⚡	⚡	⚡	INH	84		2
TAX	Transfer A to X	X ← (A)	-	-	-	-	-	-	INH	97		1
TPA	Transfer CCR to A	A ← (CCR)	-	-	-	-	-	-	INH	85		1
TST <i>opr</i> TSTA TSTX TST <i>opr</i> ,X TST ,X TST <i>opr</i> ,SP	Test for Negative or Zero	(A) - \$00 or (X) - \$00 or (M) - \$00	0	-	-	⚡	⚡	-	DIR INH INH IX1 IX SP1	3D 4D 5D 6D 7D 9E6D	dd  ff ff	3 1 1 3 2 4
TSX	Transfer SP to H:X	H:X ← (SP) + 1	-	-	-	-	-	-	INH	95		2
TXA	Transfer X to A	A ← (X)	-	-	-	-	-	-	INH	9F		1
TXS	Transfer H:X to SP	(SP) ← (H:X) - 1	-	-	-	-	-	-	INH	94		2

- |       |   |            |   |
|-------|---|------------|---|
| A     | Accumulator   | <i>n</i>   | Any bit                                     |
| C     | Carry/borrow bit  | <i>opr</i> | Operand (one or two bytes)                  |
| CCR   | Condition code register   | PC         | Program counter                             |
| dd    | Direct address of operand   | PCH        | Program counter high byte                   |
| dd rr | Direct address of operand and relative offset of branch instruction | PCL        | Program counter low byte                    |
| DD    | Direct to direct addressing mode                                    | REL        | Relative addressing mode                    |
| DIR   | Direct addressing mode  | <i>rel</i> | Relative program counter offset byte        |
| DIX+  | Direct to indexed with post increment addressing mode               | rr         | Relative program counter offset byte        |
| ee ff | High and low bytes of offset in indexed, 16-bit offset addressing   | SP1        | Stack pointer, 8-bit offset addressing mode |
| EXT   | Extended addressing mode  | SP2        | Stack pointer 16-bit offset addressing mode |
| ff    | Offset byte in indexed, 8-bit offset addressing                     | SP         | Stack pointer                               |
| H     | Half-carry bit  | U          | Undefined                                   |
| H     | Index register high byte  | V          | Overflow bit                                |
| hh ll | High and low bytes of operand address in extended addressing        | X          | Index register low byte                     |
| I     | Interrupt mask  | Z          | Zero bit                                    |
| ii    | Immediate operand byte  | &          | Logical AND                                 |
| IMD   | Immediate source to direct destination addressing mode              |            | Logical OR                                  |
| IMM   | Immediate addressing mode   | ⊕          | Logical EXCLUSIVE OR                        |
| INH   | Inherent addressing mode  | ()         | Contents of                                 |
| IX    | Indexed, no offset addressing mode                                  | -()        | Negation (two's complement)                 |
| IX+   | Indexed, no offset, post increment addressing mode                  | #          | Immediate value                             |
| IX+D  | Indexed with post increment to direct addressing mode               | «          | Sign extend                                 |
| IX1   | Indexed, 8-bit offset addressing mode                               | ←          | Loaded with                                 |
| IX1+  | Indexed, 8-bit offset, post increment addressing mode               | ?          | If  |
| IX2   | Indexed, 16-bit offset addressing mode                              | :          | Concatenated with                           |
| M     | Memory location   | ⚡          | Set or cleared                              |
| N     | Negative bit  | —          | Not affected                                |

**Central Processor Unit (CPU)**

**Table 6-2. Opcode Map**

MSB LSB	Bit Manipulation			Branch			Read-Modify-Write			Control			Register/Memory							
	DIR	DIR	REL	REL	DIR	DIR	INH	DIR	SP1	IX	INH	INH	IMM	DIR	EXT	IX2	SP2	IX1	SP1	IX
0	5	4	2	3	4	3	1	6	9E6	7	8	9	A	B	C	D	9ED	E	9EE	F
0	BRSET0 3 DIR	BSET0 2 DIR	BRA 2 REL	NEG 2 DIR	NEG 1 INH	NEG 1 INH	1	4	5	5	7	BGE 2 REL	2	3	4	4	5	3	4	2
1	BRCLR0 3 DIR	BCLR0 2 DIR	BRN 2 REL	CBEQ 3 DIR	CBEQ 3 IMM	CBEQ 3 IMM	4	5	6	4	4	RTS 1 INH	2	3	4	4	5	3	4	2
2	BRSET1 3 DIR	BSET1 2 DIR	BHI 2 REL	MUL 1 INH	DIV 1 INH	NSA 1 INH	7	3	3	2	2	BGT 2 REL	2	3	4	4	5	3	4	2
3	BRCLR1 3 DIR	BCLR1 2 DIR	BLS 2 REL	COMA 1 INH	COMX 1 INH	COM 1 INH	9	5	5	3	9	SWI 1 INH	2	3	4	4	5	3	4	2
4	BRSET2 3 DIR	BSET2 2 DIR	BCC 2 REL	LSRA 1 INH	LSRX 1 INH	LSR 1 INH	3	4	5	3	3	TAP 1 INH	2	3	4	4	5	3	4	2
5	BRCLR2 3 DIR	BCLR2 2 DIR	BCS 2 REL	LDHX 2 IMM	LDHX 2 DIR	CPHX 2 IMM	4	3	3	2	4	TPA 1 INH	2	3	4	4	5	3	4	2
6	BRSET3 3 DIR	BSET3 2 DIR	BNE 2 REL	RORA 1 INH	ROFX 1 INH	ROR 1 INH	2	4	5	3	2	PULA 1 INH	2	3	4	4	5	3	4	2
7	BRCLR3 3 DIR	BCLR3 2 DIR	BEQ 2 REL	ASRA 1 INH	ASRX 1 INH	ASR 1 INH	2	4	5	3	2	PSHA 1 INH	2	3	4	4	5	3	4	2
8	BRSET4 3 DIR	BSET4 2 DIR	BHCC 2 REL	LSLA 1 INH	LSLX 1 INH	LSL 1 INH	3	4	5	3	2	CLC 1 INH	2	3	4	4	5	3	4	2
9	BRCLR4 3 DIR	BCLR4 2 DIR	BHCS 2 REL	ROLA 1 INH	ROXL 1 INH	ROL 1 INH	4	5	5	3	3	PSHX 1 INH	2	3	4	4	5	3	4	2
A	BRSET5 3 DIR	BSET5 2 DIR	BPL 2 REL	DECA 1 INH	DECX 1 INH	DEC 1 INH	2	4	5	3	2	CJL 1 INH	2	3	4	4	5	3	4	2
B	BRCLR5 3 DIR	BCLR5 2 DIR	BMI 2 REL	DBNZ 2 INH	DBNZ 2 INH	DBNZ 2 INH	3	4	6	4	2	PSHH 1 INH	2	3	4	4	5	3	4	2
C	BRSET6 3 DIR	BSET6 2 DIR	BMC 2 REL	INCA 1 INH	INCX 1 INH	INC 1 INH	4	5	5	3	1	RSP 1 INH	2	3	4	4	5	3	4	2
D	BRCLR6 3 DIR	BCLR6 2 DIR	BMS 2 REL	TSTA 1 INH	TSTX 1 INH	TST 1 INH	3	4	4	3	2	NOP 1 INH	2	3	4	4	5	3	4	2
E	BRSET7 3 DIR	BSET7 2 DIR	BIL 2 REL	MOV 3 DD	MOV 3 DD	MOV 3 IMM	5	4	4	4	1	STOP 1 INH	2	3	4	4	5	3	4	2
F	BRCLR7 3 DIR	BCLR7 2 DIR	BIH 2 REL	CLRA 1 INH	CLR 1 INH	CLR 1 INH	3	4	4	3	2	WAIT 1 INH	2	3	4	4	5	3	4	2

MSB	0
LSB	5
0	BRSET0 3 DIR

High Byte of Opcode in Hexadecimal

Cycles  
Opcode Mnemonic  
Number of Bytes / Addressing Mode

Low Byte of Opcode in Hexadecimal

SP1 Stack Pointer, 8-Bit Offset  
SP2 Stack Pointer, 16-Bit Offset  
IX+ Indexed, No Offset with Post Increment  
IX1+ Indexed, 1-Byte Offset with Post Increment  
IX+D Indexed-Direct  
DIX+ Direct-Indexed

\* Pre-byte for stack pointer indexed instructions

## Section 7. Oscillator (OSC)

### 7.1 Contents

7.2	Introduction . . . . .	103
7.3	Internal Oscillator . . . . .	105
7.4	X-tal Oscillator . . . . .	105
7.5	I/O Signals . . . . .	105
7.5.1	Crystal Amplifier Input Pin (OSC1) . . . . .	106
7.5.2	Crystal Amplifier Output Pin (OSC2) . . . . .	106
7.5.3	Oscillator Enable Signal (SIMOSCEN) . . . . .	106
7.5.4	Internal RC Clock (ICLK) . . . . .	106
7.5.5	CGM Oscillator Clock (CGMXCLK) . . . . .	106
7.5.6	CGM Reference Clock (CGMRCLK) . . . . .	106
7.6	Low Power Modes . . . . .	106
7.6.1	Wait Mode . . . . .	107
7.6.2	Stop Mode . . . . .	107
7.7	Oscillator During Break Mode . . . . .	107

### 7.2 Introduction

The oscillator module provides the reference clock for the clock generator module (CGM), the real time clock module (RTC), and other MCU sub-systems.

The oscillator module consist of two types of oscillator circuits:

- Internal RC oscillator
- 32.768kHz crystal (x-tal) oscillator

Oscillator (OSC)

The reference clock for the CGM, real time clock module (RTC) and other MCU sub-systems is driven by the crystal oscillator. The COP module is always driven by internal RC clock.

The internal RC oscillator runs continuously after a POR or reset and is always available in run and wait modes. In stop mode, it can be disabled by setting the STOP\_IRCDIS bit in CONFIG2 register.

Figure 7-1. shows the block diagram of the oscillator module.

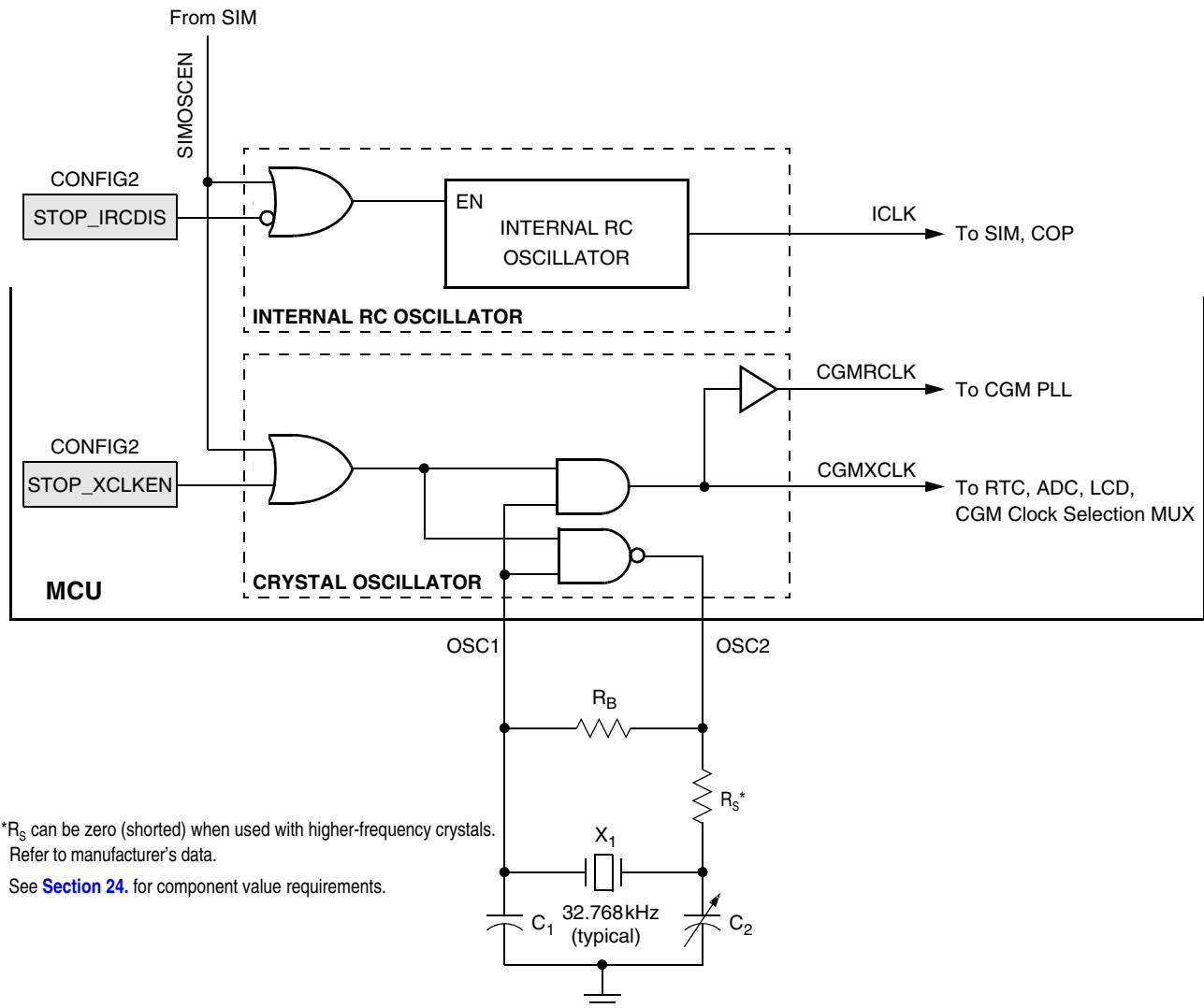


Figure 7-1. Oscillator Module Block Diagram



### 7.3 Internal Oscillator

The internal RC oscillator clock (ICLK) is a free running 64kHz clock (at  $V_{DD} = 5V$ ) that requires no external components. It is the reference clock input to the computer operating properly (COP) module.

The ICLK can be turned off in stop mode by setting the STOP\_IRCDIS bit in CONFIG2. After reset, the bit is clear by default and ICLK is enabled during stop mode.

### 7.4 X-tal Oscillator

The crystal (x-tal) oscillator circuit is designed for use with an external 32.768kHz crystal or ceramic resonator to provide an accurate clock source.

In its typical configuration, the X-tal oscillator is connected in a Pierce oscillator configuration, as shown in [Figure 7-1](#). This figure shows only the logical representation of the internal components and may not represent actual circuitry. The oscillator configuration uses five components:

- Crystal,  $X_1$  (32.768kHz)
- Fixed capacitor,  $C_1$
- Tuning capacitor,  $C_2$  (can also be a fixed capacitor)
- Feedback resistor,  $R_B$
- Series resistor,  $R_S$  (optional)

The series resistor ( $R_S$ ) is included in the diagram to follow strict Pierce oscillator guidelines and may not be required for all ranges of operation, especially with high frequency crystals. Refer to the crystal manufacturer's data for more information.

### 7.5 I/O Signals

The following paragraphs describe the oscillator I/O signals.

### 7.5.1 Crystal Amplifier Input Pin (OSC1)

OSC1 pin is an input to the crystal oscillator amplifier. Schmitt trigger and glitch filter are implemented on this pin to improve EMC performance. See [Section 24. Electrical Specifications](#) for detail specification of the glitch filter.

### 7.5.2 Crystal Amplifier Output Pin (OSC2)

OSC2 pin is the output of the crystal oscillator inverting amplifier.

### 7.5.3 Oscillator Enable Signal (SIMOSCEN)

The SIMOSCEN signal from the system integration module (SIM) enables/disables the x-tal oscillator circuit.

### 7.5.4 Internal RC Clock (ICLK)

The ICLK clock is the output from the internal RC oscillator. This clock drives the SIM and COP modules.

### 7.5.5 CGM Oscillator Clock (CGMXCLK)

The CGMXCLK clock is the output from the x-tal oscillator. This clock drives to CGM, real time clock module, analog-to-digital converter, liquid crystal display driver module, and other MCU sub-systems.

### 7.5.6 CGM Reference Clock (CGMRCLK)

This is buffered signal of CGMXCLK, it is used by the CGM as the phase-locked-loop (PLL) reference clock.

## 7.6 Low Power Modes

The WAIT and STOP instructions put the MCU in low-power consumption standby modes.

### 7.6.1 Wait Mode

The WAIT instruction has no effect on the oscillator module. CGMXCLK, CGMRCLK, and ICLK continues to drive the MCU modules.

### 7.6.2 Stop Mode

The STOP instruction clears the SIMOSCEN signal, and hence the CGMXCLK (and CGMRCLK) clock stops running. For continuous CGMXCLK operation in stop mode, set the STOP\_XCLKEN to logic 1 before entering stop mode. Continuous CGMXCLK operation in stop mode allows the RTC module to generate interrupts to wake up the CPU.

By default, the internal RC oscillator clock, ICLK, continues to run in stop mode. To disable the ICLK in stop mode, set the STOP\_IRCDIS bit to logic 1 before entering stop mode.

## 7.7 Oscillator During Break Mode

The oscillator circuits continue to drive CGMXCLK, CGMRCLK, and ICLK when the device enters the break state.



## Section 8. Clock Generator Module (CGM)

### 8.1 Contents

8.2	Introduction . . . . .	110
8.3	Features . . . . .	111
8.4	Functional Description . . . . .	111
8.4.1	Oscillator Module . . . . .	114
8.4.2	Phase-Locked Loop Circuit (PLL) . . . . .	114
8.4.3	PLL Circuits . . . . .	114
8.4.4	Acquisition and Tracking Modes . . . . .	116
8.4.5	Manual and Automatic PLL Bandwidth Modes. . . . .	116
8.4.6	Programming the PLL . . . . .	118
8.4.7	Special Programming Exceptions . . . . .	122
8.4.8	Base Clock Selector Circuit . . . . .	122
8.4.9	CGM External Connections . . . . .	123
8.5	I/O Signals . . . . .	123
8.5.1	External Filter Capacitor Pin (CGMXFC) . . . . .	124
8.5.2	PLL Analog Power Pin ( $V_{DDA}$ ) . . . . .	124
8.5.3	PLL Analog Ground Pin ( $V_{SSA}$ ) . . . . .	124
8.5.4	Oscillator Output Frequency Signal (CGMXCLK) . . . . .	124
8.5.5	CGM Reference Clock (CGMRCLK) . . . . .	124
8.5.6	CGM VCO Clock Output (CGMVCLK) . . . . .	125
8.5.7	CGM Base Clock Output (CGMOUT) . . . . .	125
8.5.8	CGM CPU Interrupt (CGMINT) . . . . .	125
8.6	CGM Registers . . . . .	125
8.6.1	PLL Control Register . . . . .	126
8.6.2	PLL Bandwidth Control Register . . . . .	128
8.6.3	PLL Multiplier Select Registers . . . . .	130
8.6.4	PLL VCO Range Select Register . . . . .	131
8.6.5	PLL Reference Divider Select Register . . . . .	132

8.7 Interrupts . . . . . 133

8.8 Special Modes . . . . . 133

8.8.1 Wait Mode . . . . . 133

8.8.2 Stop Mode . . . . . 134

8.8.3 CGM During Break Interrupts . . . . . 134

8.9 Acquisition/Lock Time Specifications . . . . . 135

8.9.1 Acquisition/Lock Time Definitions . . . . . 135

8.9.2 Parametric Influences on Reaction Time . . . . . 135

8.9.3 Choosing a Filter . . . . . 137

## 8.2 Introduction

This section describes the clock generator module (CGM). The CGM generates the base clock signal, CGMOUT, which is based on either the oscillator clock divided by two or the divided phase-locked loop (PLL) clock, CGMPCLK, divided by two. CGMOUT is the clock from which the SIM derives the system clocks, including the bus clock, which is at a frequency of  $CGMOUT \div 2$ .

The PLL is a frequency generator designed for use with a low frequency crystal (typically 32.768kHz) to generate a base frequency and dividing to a maximum bus frequency of 8MHz.

## 8.3 Features

Features of the CGM include:

- Phase-locked loop with output frequency in integer multiples of an integer dividend of the crystal reference
- Low-frequency crystal operation with low-power operation and high-output frequency resolution
- Programmable prescaler for power-of-two increases in frequency
- Programmable hardware voltage-controlled oscillator (VCO) for low-jitter operation
- Automatic bandwidth control mode for low-jitter operation
- Automatic frequency lock detector
- CPU interrupt on entry or exit from locked condition
- Configuration register bit to allow oscillator operation during stop mode

## 8.4 Functional Description

The CGM consists of three major sub-modules:

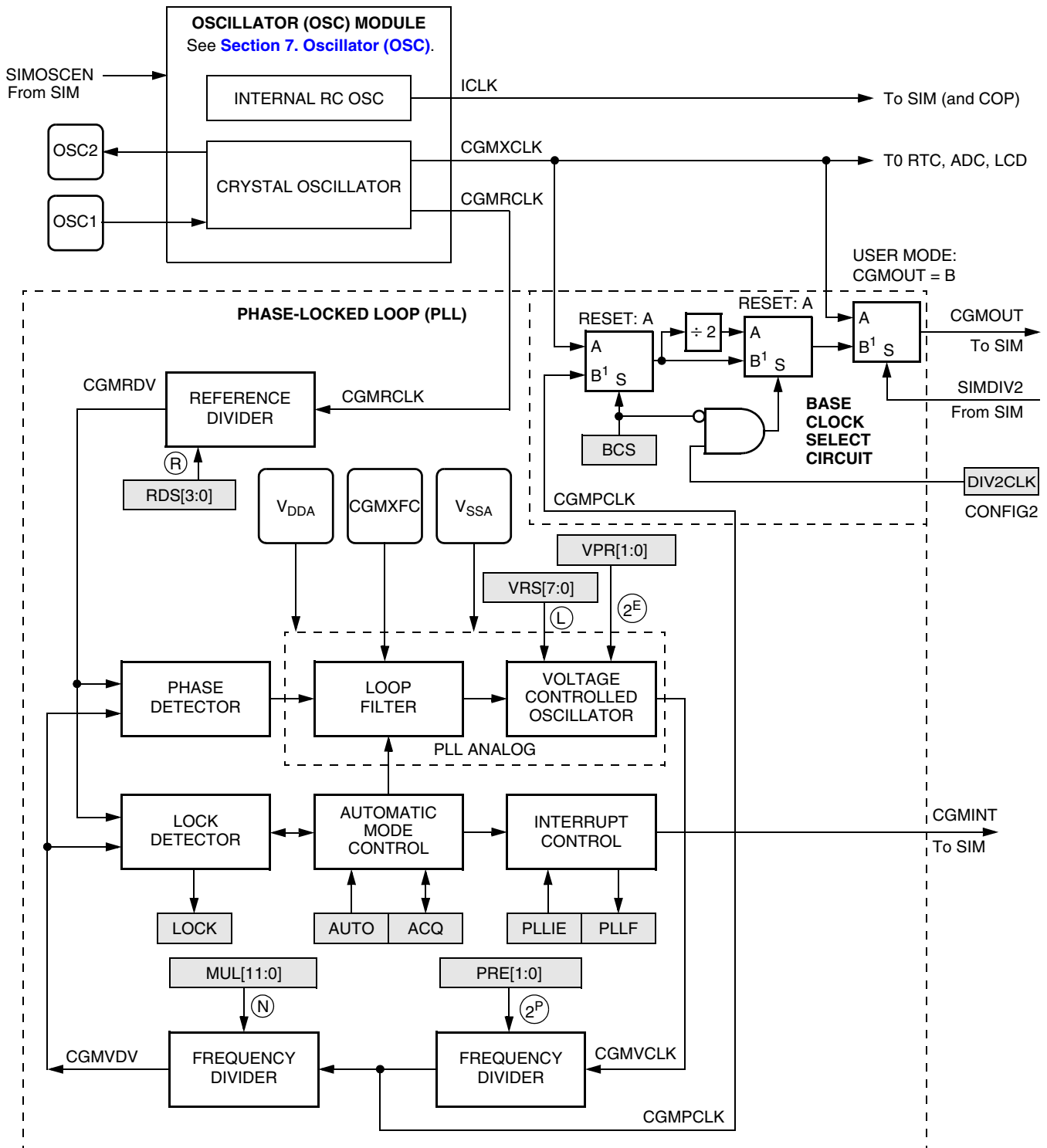
- Oscillator module — The oscillator module generates the constant reference frequency clock, CGMRCLK (buffered CGMXCLK).
- Phase-locked loop (PLL) — The PLL generates the programmable VCO frequency clock, CGMVCLK, and the divided, CGMPCLK. The CGMPCLK is one of the reference clocks to the base clock selector circuit.
- Base clock selector circuit — This software-controlled circuit selects the one of three clocks as the base clock, CGMOUT: CGMXCLK, CGMXCLK divided by two, or CGMPCLK divided by two.

**Figure 8-1** shows the structure of the CGM.

**Figure 8-2** is a summary of the CGM registers.

**Clock Generator Module (CGM)**

Freescale Semiconductor, Inc.



**Figure 8-1. CGM Block Diagram**



Addr.	Register Name	Bit 7	6	5	4	3	2	1	Bit 0	
\$0036	PLL Control Register (PTCL)	Read:	PLLIE	PLLF	PLLON	BCS	PRE1	PRE0	VPR1	VPR0
		Write:								
		Reset:	0	0	1	0	0	0	0	0
\$0037	PLL Bandwidth Control Register (PBWC)	Read:	AUTO	LOCK	ACQ	0	0	0	0	R
		Write:								
		Reset:	0	0	0	0	0	0	0	0
\$0038	PLL Multiplier Select Register High (PMSH)	Read:	0	0	0	0	MUL11	MUL10	MUL9	MUL8
		Write:								
		Reset:	0	0	0	0	0	0	0	0
\$0039	PLL Multiplier Select Register Low (PMSL)	Read:	MUL7	MUL6	MUL5	MUL4	MUL3	MUL2	MUL1	MUL0
		Write:								
		Reset:	0	1	0	0	0	0	0	0
\$003A	PLL VCO Range Select Register (PMRS)	Read:	VRS7	VRS6	VRS5	VRS4	VRS3	VRS2	VRS1	VRS0
		Write:								
		Reset:	0	1	0	0	0	0	0	0
\$003B	PLL Reference Divider Select Register (PMDS)	Read:	0	0	0	0	RDS3	RDS2	RDS1	RDS0
		Write:								
		Reset:	0	0	0	0	0	0	0	1

= Unimplemented
 R = Reserved

**NOTES:**

1. When AUTO = 0, PLLIE is forced clear and is read-only.
2. When AUTO = 0, PLLF and LOCK read as clear.
3. When AUTO = 1, ACQ is read-only.
4. When PLLON = 0 or VRS7:VRS0 = \$0, BCS is forced clear and is read-only.
5. When PLLON = 1, the PLL programming register is read-only.
6. When BCS = 1, PLLON is forced set and is read-only.

**Figure 8-2. CGM I/O Register Summary**

### 8.4.1 Oscillator Module

The oscillator module provides two clock outputs CGMXCLK and CGMRCLK to the CGM module. CGMXCLK or CGMXCLK divide-by-two can be selected to drive the SIM module to generate the system bus clocks. CGMRCLK is the reference clock for the phase-lock-loop, to generate a higher frequency clock. The oscillator module also provides the reference clock for the real time clock (RTC) module.

See [Section 7. Oscillator \(OSC\)](#) for detailed description on oscillator module. See [Section 12. Real Time Clock \(RTC\)](#) for detailed description on RTC.

### 8.4.2 Phase-Locked Loop Circuit (PLL)

The PLL is a frequency generator that can operate in either acquisition mode or tracking mode, depending on the accuracy of the output frequency. The PLL can change between acquisition and tracking modes either automatically or manually.

### 8.4.3 PLL Circuits

The PLL consists of these circuits:

- Voltage-controlled oscillator (VCO)
- Reference divider
- Frequency pre-scaler
- Modulo VCO frequency divider
- Phase detector
- Loop filter
- Lock detector

The operating range of the VCO is programmable for a wide range of frequencies and for maximum immunity to external noise, including supply and CGMXFC noise. The VCO frequency is bound to a range from roughly one-half to twice the center-of-range frequency,  $f_{VRS}$ . Modulating the voltage on the CGMXFC pin changes the frequency within this range. By design,  $f_{VRS}$  is equal to the nominal center-of-range frequency,  $f_{NOM}$ , (38.4 kHz) times a linear factor,  $L$ , and a power-of-two factor,  $E$ , or  $(L \times 2^E)f_{NOM}$ .

CGMRCLK is the PLL reference clock, a buffered version of CGMXCLK. CGMRCLK runs at a frequency,  $f_{RCLK}$ , and is fed to the PLL through a programmable modulo reference divider, which divides  $f_{RCLK}$  by a factor,  $R$ . The divider's output is the final reference clock, CGMRDV, running at a frequency,  $f_{RDV} = f_{RCLK}/R$ . With an external crystal (30kHz–100kHz), always set  $R = 1$  for specified performance. With an external high-frequency clock source, use  $R$  to divide the external frequency to between 30kHz and 100kHz.

The VCO's output clock, CGMVCLK, running at a frequency,  $f_{VCLK}$ , is fed back through a programmable pre-scaler divider and a programmable modulo divider. The pre-scaler divides the VCO clock by a power-of-two factor  $P$  (the CGMPCLK) and the modulo divider reduces the VCO clock by a factor,  $N$ . The dividers' output is the VCO feedback clock, CGMVDV, running at a frequency,  $f_{VDV} = f_{VCLK}/(N \times 2^P)$ . (See [8.4.6 Programming the PLL](#) for more information.)

The phase detector then compares the VCO feedback clock, CGMVDV, with the final reference clock, CGMRDV. A correction pulse is generated based on the phase difference between the two signals. The loop filter then slightly alters the DC voltage on the external capacitor connected to CGMXFC based on the width and direction of the correction pulse. The filter can make fast or slow corrections depending on its mode, described in [8.4.4 Acquisition and Tracking Modes](#). The value of the external capacitor and the reference frequency determines the speed of the corrections and the stability of the PLL.

The lock detector compares the frequencies of the VCO feedback clock, CGMVDV, and the final reference clock, CGMRDV. Therefore, the speed of the lock detector is directly proportional to the final reference frequency,  $f_{RDV}$ . The circuit determines the mode of the PLL and the lock condition based on this comparison.

#### 8.4.4 Acquisition and Tracking Modes

The PLL filter is manually or automatically configurable into one of two operating modes:

- Acquisition mode — In acquisition mode, the filter can make large frequency corrections to the VCO. This mode is used at PLL start up or when the PLL has suffered a severe noise hit and the VCO frequency is far off the desired frequency. When in acquisition mode, the  $\overline{\text{ACQ}}$  bit is clear in the PLL bandwidth control register. (See [8.6.2 PLL Bandwidth Control Register](#).)
- Tracking mode — In tracking mode, the filter makes only small corrections to the frequency of the VCO. PLL jitter is much lower in tracking mode, but the response to noise is also slower. The PLL enters tracking mode when the VCO frequency is nearly correct, such as when the PLL is selected as the base clock source. (See [8.4.8 Base Clock Selector Circuit](#).) The PLL is automatically in tracking mode when not in acquisition mode or when the  $\overline{\text{ACQ}}$  bit is set.

#### 8.4.5 Manual and Automatic PLL Bandwidth Modes

The PLL can change the bandwidth or operational mode of the loop filter manually or automatically. Automatic mode is recommended for most users.

In automatic bandwidth control mode (AUTO = 1), the lock detector automatically switches between acquisition and tracking modes. Automatic bandwidth control mode also is used to determine when the VCO clock, CGMVCLK, is safe to use as the source for the base clock, CGMOUT. (See [8.6.2 PLL Bandwidth Control Register](#).) If PLL interrupts are enabled, the software can wait for a PLL interrupt request and then check the LOCK bit. If interrupts are disabled, software can poll the LOCK bit continuously (during PLL start-up, usually) or at periodic intervals. In either case, when the LOCK bit is set, the VCO clock is safe to use as the source for the base clock. (See [8.4.8 Base Clock Selector Circuit](#).) If the VCO is selected as the source for the base clock and the LOCK bit is clear, the PLL has suffered a severe noise hit and the software must take appropriate action, depending on the application. (See [8.7 Interrupts](#) for information and precautions on using interrupts.)

The following conditions apply when the PLL is in automatic bandwidth control mode:

- The  $\overline{\text{ACQ}}$  bit (See [8.6.2 PLL Bandwidth Control Register](#).) is a read-only indicator of the mode of the filter. (See [8.4.4 Acquisition and Tracking Modes](#).)
- The  $\overline{\text{ACQ}}$  bit is set when the VCO frequency is within a certain tolerance and is cleared when the VCO frequency is out of a certain tolerance. (See [8.9 Acquisition/Lock Time Specifications](#) for more information.)
- The LOCK bit is a read-only indicator of the locked state of the PLL.
- The LOCK bit is set when the VCO frequency is within a certain tolerance and is cleared when the VCO frequency is out of a certain tolerance. (See [8.9 Acquisition/Lock Time Specifications](#) for more information.)
- CPU interrupts can occur if enabled ( $\text{PLLIE} = 1$ ) when the PLL's lock condition changes, toggling the LOCK bit. (See [8.6.1 PLL Control Register](#).)

The PLL also may operate in manual mode ( $\text{AUTO} = 0$ ). Manual mode is used by systems that do not require an indicator of the lock condition for proper operation. Such systems typically operate well below  $f_{\text{BUSMAX}}$ .

The following conditions apply when in manual mode:

- $\overline{ACQ}$  is a writable control bit that controls the mode of the filter. Before turning on the PLL in manual mode, the  $\overline{ACQ}$  bit must be clear.
- Before entering tracking mode ( $\overline{ACQ} = 1$ ), software must wait a given time,  $t_{ACQ}$  (See [8.9 Acquisition/Lock Time Specifications](#)), after turning on the PLL by setting PLLON in the PLL control register (PCTL).
- Software must wait a given time,  $t_{AL}$ , after entering tracking mode before selecting the PLL as the clock source to CGMOUT ( $BCS = 1$ ).
- The LOCK bit is disabled.
- CPU interrupts from the CGM are disabled.

#### 8.4.6 Programming the PLL

The following procedure shows how to program the PLL.

**NOTE:** *The round function in the following equations means that the real number should be rounded to the nearest integer number.*

1. Choose the desired bus frequency,  $f_{BUSDES}$ .
2. Calculate the desired VCO frequency,  $f_{VCLKDES}$ .

$$f_{VCLKDES} = 2^P \times f_{CGMPCLK} = 2^P \times 4 \times f_{BUSDES}$$

where P is the power of two multiplier, and can be 0, 1, 2, or 3

3. Choose a practical PLL reference frequency,  $f_{RCLK}$ , and the reference clock divider, R. Typically, the reference is 32.768kHz and  $R = 1$ .

Frequency errors to the PLL are corrected at a rate of  $f_{RCLK}/R$ . For stability and lock time reduction, this rate must be as fast as possible. The VCO frequency must be an integer multiple of this rate.

The relationship between the VCO frequency,  $f_{VCLK}$ , and the reference frequency,  $f_{RCLK}$ , is

$$f_{VCLK} = \frac{2^P N}{R} (f_{RCLK})$$

where N is the integer range multiplier, between 1 and 4095.

In cases where desired bus frequency has some tolerance, choose  $f_{RCLK}$  to a value determined either by other module requirements (such as modules which are clocked by CGMXCLK), cost requirements, or ideally, as high as the specified range allows. See **Section 24. Electrical Specifications**. Choose the reference divider,  $R = 1$ .

When the tolerance on the bus frequency is tight, choose  $f_{RCLK}$  to an integer divisor of  $f_{BUSDES}$ , and  $R = 1$ . If  $f_{RCLK}$  cannot meet this requirement, use the following equation to solve for R with practical choices of  $f_{RCLK}$ , and choose the  $f_{RCLK}$  that gives the lowest R.

$$R = \text{round} \left[ R_{MAX} \times \left\{ \left( \frac{f_{VCLKDES}}{f_{RCLK}} \right) - \text{integer} \left( \frac{f_{VCLKDES}}{f_{RCLK}} \right) \right\} \right]$$

4. Calculate N:

$$N = \text{round} \left( \frac{R \times f_{VCLKDES}}{f_{RCLK} \times 2^P} \right)$$

5. Calculate and verify the adequacy of the VCO and bus frequencies  $f_{VCLK}$  and  $f_{BUS}$ .

$$f_{VCLK} = \frac{2^P N}{R} (f_{RCLK})$$

$$f_{BUS} = \frac{f_{VCLK}}{2^P \times 4}$$

6. Select the VCO's power-of-two range multiplier E, according to this table:

Frequency Range	E
$0 < f_{VCLK} < 9,830,400$	0
$9,830,400 \leq f_{VCLK} < 19,660,800$	1
$19,660,800 \leq f_{VCLK} < 39,321,600$	2

NOTE: Do not program E to a value of 3.

7. Select a VCO linear range multiplier, L, where  $f_{NOM} = 38.4\text{ kHz}$

$$L = \text{round}\left(\frac{f_{VCLK}}{2^E \times f_{NOM}}\right)$$

8. Calculate and verify the adequacy of the VCO programmed center-of-range frequency,  $f_{VRS}$ . The center-of-range frequency is the midpoint between the minimum and maximum frequencies attainable by the PLL.

$$f_{VRS} = (L \times 2^E) f_{NOM}$$

For proper operation,

$$|f_{VRS} - f_{VCLK}| \leq \frac{f_{NOM} \times 2^E}{2}$$

9. Verify the choice of P, R, N, E, and L by comparing  $f_{VCLK}$  to  $f_{VRS}$  and  $f_{VCLKDES}$ . For proper operation,  $f_{VCLK}$  must be within the application's tolerance of  $f_{VCLKDES}$ , and  $f_{VRS}$  must be as close as possible to  $f_{VCLK}$ .

**NOTE:** Exceeding the recommended maximum bus frequency or VCO frequency can crash the MCU.



10. Program the PLL registers accordingly:
  - a. In the PRE bits of the PLL control register (PCTL), program the binary equivalent of P.
  - b. In the VPR bits of the PLL control register (PCTL), program the binary equivalent of E.
  - c. In the PLL multiplier select register low (PMSL) and the PLL multiplier select register high (PMSH), program the binary equivalent of N.
  - d. In the PLL VCO range select register (PMRS), program the binary coded equivalent of L.
  - e. In the PLL reference divider select register (PMDS), program the binary coded equivalent of R.

**NOTE:** The values for P, E, N, L, and R can only be programmed when the PLL is off (PLLON = 0).

**Table 8-1** provides numeric examples (numbers are in hexadecimal notation):

**Table 8-1. Numeric Examples**

CGMVCLK	CGMPCLK	f <sub>BUS</sub>	f <sub>RCLK</sub>	R	N	P	E	L
8.0 MHz	8.0 MHz	2.0 MHz	32.768 kHz	1	F5	0	0	D1
9.8304 MHz	9.8304 MHz	2.4576 MHz	32.768 kHz	1	12C	0	1	80
10.0 MHz	10.0 MHz	2.5 MHz	32.768 kHz	1	132	0	1	83
16 MHz	16 MHz	4.0 MHz	32.768 kHz	1	1E9	0	1	D1
19.6608 MHz	19.6608 MHz	4.9152 MHz	32.768 kHz	1	258	0	2	80
20 MHz	20 MHz	5.0 MHz	32.768 kHz	1	263	0	2	82
29.4912 MHz	29.4912 MHz	7.3728 MHz	32.768 kHz	1	384	0	2	C0
32 MHz	32 MHz	8.0 MHz	32.768 kHz	1	3D1	0	2	D0
32 MHz	16 MHz	4.0 MHz	32.768 kHz	1	1E9	1	2	D0
32 MHz	8 MHz	2.0 MHz	32.768 kHz	1	F5	2	2	D0
32 MHz	4 MHz	1.0 MHz	32.768 kHz	1	7B	3	2	D0

### 8.4.7 Special Programming Exceptions

The programming method described in [8.4.6 Programming the PLL](#) does not account for three possible exceptions. A value of 0 for R, N, or L is meaningless when used in the equations given. To account for these exceptions:

- A 0 value for R or N is interpreted exactly the same as a value of 1.
- A 0 value for L disables the PLL and prevents its selection as the source for the base clock.

(See [8.4.8 Base Clock Selector Circuit](#).)

### 8.4.8 Base Clock Selector Circuit

This circuit is used to select either the oscillator clock, CGMXCLK, or the divided VCO clock, CGMPCLK, as the source of the base clock, CGMOUT. The two input clocks go through a transition control circuit that waits up to three CGMXCLK cycles and three CGMPCLK cycles to change from one clock source to the other. During this time, CGMOUT is held in stasis. The output of the transition control circuit is then divided by two to correct the duty cycle. Therefore, the bus clock frequency, which is one-half of CGMOUT, is one-fourth the frequency of the selected clock (CGMXCLK or CGMPCLK).

For the CGMXCLK, the divide-by-2 can be by-passed by setting the DIV2CLK bit in the CONFIG2 register. Therefore, the bus clock frequency can be one-half of CGMXCLK.

The BCS bit in the PLL control register (PCTL) selects which clock drives CGMOUT. The divided VCO clock cannot be selected as the base clock source if the PLL is not turned on. The PLL cannot be turned off if the divided VCO clock is selected. The PLL cannot be turned on or off simultaneously with the selection or deselection of the divided VCO clock. The divided VCO clock also cannot be selected as the base clock source if the factor L is programmed to a 0. This value would set up a condition inconsistent with the operation of the PLL, so that the PLL would be disabled and the oscillator clock would be forced as the source of the base clock.

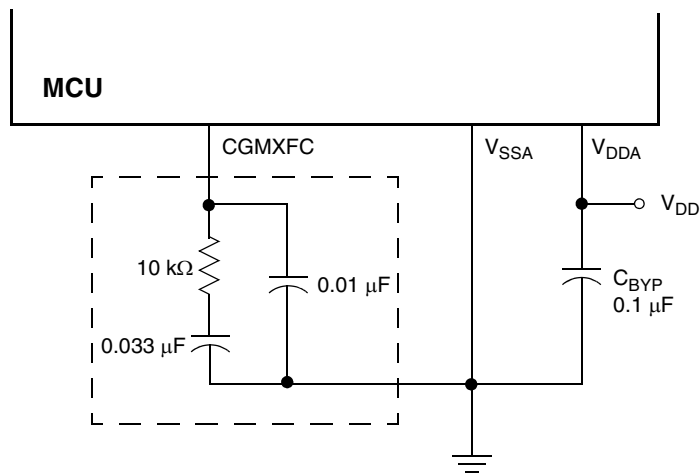
### 8.4.9 CGM External Connections

In its typical configuration, the CGM requires up to four external components.

**Figure 8-3** shows the external components for the PLL:

- Bypass capacitor,  $C_{BYP}$
- Filter network

Care should be taken with PCB routing in order to minimize signal cross talk and noise. (See **8.9 Acquisition/Lock Time Specifications** for routing information, filter network and its effects on PLL performance.)



Note: Filter network in box can be replaced with a 0.47 μF capacitor, but will degrade stability.

**Figure 8-3. CGM External Connections**

### 8.5 I/O Signals

The following paragraphs describe the CGM I/O signals.

## Clock Generator Module (CGM)

## 8.5.1 External Filter Capacitor Pin (CGMXFC)

The CGMXFC pin is required by the loop filter to filter out phase corrections. An external filter network is connected to this pin. (See [Figure 8-3](#).)

**NOTE:** *To prevent noise problems, the filter network should be placed as close to the CGMXFC pin as possible, with minimum routing distances and no routing of other signals across the network.*

8.5.2 PLL Analog Power Pin ( $V_{DDA}$ )

$V_{DDA}$  is a power pin used by the analog portions of the PLL. Connect the  $V_{DDA}$  pin to the same voltage potential as the  $V_{DD}$  pin.

**NOTE:** *Route  $V_{DDA}$  carefully for maximum noise immunity and place bypass capacitors as close as possible to the package.*

8.5.3 PLL Analog Ground Pin ( $V_{SSA}$ )

$V_{SSA}$  is a ground pin used by the analog portions of the PLL. Connect the  $V_{SSA}$  pin to the same voltage potential as the  $V_{SS}$  pin.

**NOTE:** *Route  $V_{SSA}$  carefully for maximum noise immunity and place bypass capacitors as close as possible to the package.*

**NOTE:** *On this MCU, the  $V_{SSA}$  is physically bonded to the  $V_{SS}$  pin.*

## 8.5.4 Oscillator Output Frequency Signal (CGMXCLK)

CGMXCLK is the oscillator output signal. It runs at the full speed of the oscillator, and is generated directly from the crystal oscillator circuit, the RC oscillator circuit, or the internal oscillator circuit.

## 8.5.5 CGM Reference Clock (CGMRCLK)

CGMRCLK is a buffered version of CGMXCLK, this clock is the reference clock for the phase-locked-loop circuit.

### 8.5.6 CGM VCO Clock Output (CGMVCLK)

CGMVCLK is the clock output from the VCO.

### 8.5.7 CGM Base Clock Output (CGMOUT)

CGMOUT is the clock output of the CGM. This signal goes to the SIM, which generates the MCU clocks. CGMOUT is a 50 percent duty cycle clock running at twice the bus frequency. CGMOUT is software programmable to be equal to CGMXCLK, CGMXCLK divided by two, or CGMPCLK divided by two.

### 8.5.8 CGM CPU Interrupt (CGMINT)

CGMINT is the interrupt signal generated by the PLL lock detector.

## 8.6 CGM Registers

The following registers control and monitor operation of the CGM:

- PLL control register (PCTL)  
(See [8.6.1 PLL Control Register](#).)
- PLL bandwidth control register (PBWC)  
(See [8.6.2 PLL Bandwidth Control Register](#).)
- PLL multiplier select registers (PMSH and PMSL)  
(See [8.6.3 PLL Multiplier Select Registers](#).)
- PLL VCO range select register (PMRS)  
(See [8.6.4 PLL VCO Range Select Register](#).)
- PLL reference divider select register (PMDS)  
(See [8.6.5 PLL Reference Divider Select Register](#).)

8.6.1 PLL Control Register

The PLL control register (PCTL) contains the interrupt enable and flag bits, the on/off switch, the base clock selector bit, the prescaler bits, and the VCO power-of-two range selector bits.

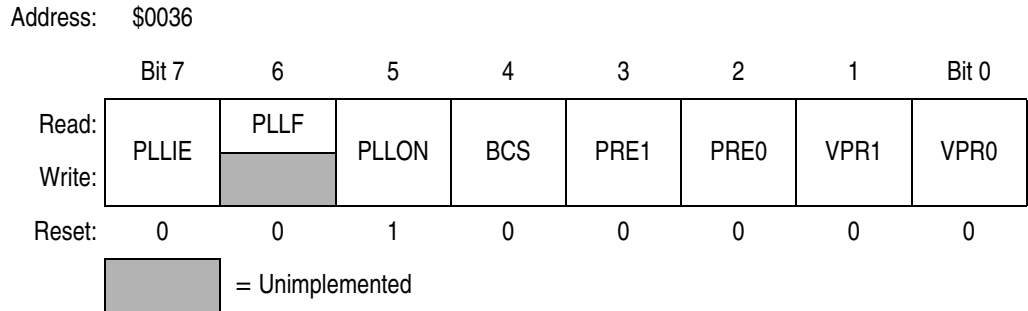


Figure 8-4. PLL Control Register (PCTL)

PLLIE — PLL Interrupt Enable Bit

This read/write bit enables the PLL to generate an interrupt request when the LOCK bit toggles, setting the PLL flag, PLLIF. When the AUTO bit in the PLL bandwidth control register (PBWC) is clear, PLLIE cannot be written and reads as logic 0. Reset clears the PLLIE bit.

- 1 = PLL interrupts enabled
- 0 = PLL interrupts disabled

PLLIF — PLL Interrupt Flag Bit

This read-only bit is set whenever the LOCK bit toggles. PLLIF generates an interrupt request if the PLLIE bit also is set. PLLIF always reads as logic 0 when the AUTO bit in the PLL bandwidth control register (PBWC) is clear. Clear the PLLIF bit by reading the PLL control register. Reset clears the PLLIF bit.

- 1 = Change in lock condition
- 0 = No change in lock condition

**NOTE:** Do not inadvertently clear the PLLIF bit. Any read or read-modify-write operation on the PLL control register clears the PLLIF bit.

## PLLON — PLL On Bit

This read/write bit activates the PLL and enables the VCO clock, CGMVCLK. PLLON cannot be cleared if the VCO clock is driving the base clock, CGMOUT (BCS = 1). (See [8.4.8 Base Clock Selector Circuit](#).) Reset sets this bit so that the loop can stabilize as the MCU is powering up.

1 = PLL on

0 = PLL off

## BCS — Base Clock Select Bit

This read/write bit selects either the oscillator output, CGMXCLK, or the divided VCO clock, CGMPCLK, as the source of the CGM output, CGMOUT. CGMOUT frequency is one-half the frequency of the selected clock. BCS cannot be set while the PLLON bit is clear. After toggling BCS, it may take up to three CGMXCLK and three CGMPCLK cycles to complete the transition from one source clock to the other. During the transition, CGMOUT is held in stasis. (See [8.4.8 Base Clock Selector Circuit](#).) Reset clears the BCS bit.

1 = CGMPCLK divided by two drives CGMOUT

0 = CGMXCLK divided by two drives CGMOUT

**NOTE:** *PLLON and BCS have built-in protection that prevents the base clock selector circuit from selecting the VCO clock as the source of the base clock if the PLL is off. Therefore, PLLON cannot be cleared when BCS is set, and BCS cannot be set when PLLON is clear. If the PLL is off (PLLON = 0), selecting CGMPCLK requires two writes to the PLL control register. (See [8.4.8 Base Clock Selector Circuit](#).)*

## PRE1 and PRE0 — Prescaler Program Bits

These read/write bits control a prescaler that selects the prescaler power-of-two multiplier, P. (See [8.4.3 PLL Circuits](#) and [8.4.6 Programming the PLL](#).) PRE1 and PRE0 cannot be written when the PLLON bit is set. Reset clears these bits.

These prescaler bits affects the relationship between the VCO clock and the final system bus clock.

Table 8-2. PRE 1 and PRE0 Programming

PRE1 and PRE0	P	Prescaler Multiplier
00	0	1
01	1	2
10	2	4
11	3	8

VPR1 and VPR0 — VCO Power-of-Two Range Select Bits

These read/write bits control the VCO’s hardware power-of-two range multiplier E that, in conjunction with L (See [8.4.3 PLL Circuits](#), [8.4.6 Programming the PLL](#), and [8.6.4 PLL VCO Range Select Register](#).) controls the hardware center-of-range frequency,  $f_{VRS}$ . VPR1:VPR0 cannot be written when the PLLON bit is set. Reset clears these bits.

Table 8-3. VPR1 and VPR0 Programming

VPR1 and VPR0	E	VCO Power-of-Two Range Multiplier
00	0	1
01	1	2
10	2	4

NOTE: Do not program E to a value of 3.

8.6.2 PLL Bandwidth Control Register

The PLL bandwidth control register (PBWC):

- Selects automatic or manual (software-controlled) bandwidth control mode
- Indicates when the PLL is locked
- In automatic bandwidth control mode, indicates when the PLL is in acquisition or tracking mode
- In manual operation, forces the PLL into acquisition or tracking mode



Address: \$0037

	Bit 7	6	5	4	3	2	1	Bit 0
Read:	AUTO	LOCK	$\overline{\text{ACQ}}$	0	0	0	0	R
Write:								
Reset:	0	0	0	0	0	0	0	0

= Unimplemented
  = Reserved

**Figure 8-5. PLL Bandwidth Control Register (PBWCR)**

**AUTO — Automatic Bandwidth Control Bit**

This read/write bit selects automatic or manual bandwidth control. When initializing the PLL for manual operation (AUTO = 0), clear the  $\overline{\text{ACQ}}$  bit before turning on the PLL. Reset clears the AUTO bit.

- 1 = Automatic bandwidth control
- 0 = Manual bandwidth control

**LOCK — Lock Indicator Bit**

When the AUTO bit is set, LOCK is a read-only bit that becomes set when the VCO clock, CGMVCLK, is locked (running at the programmed frequency). When the AUTO bit is clear, LOCK reads as logic 0 and has no meaning. The write one function of this bit is reserved for test, so this bit must *always* be written a 0. Reset clears the LOCK bit.

- 1 = VCO frequency correct or locked
- 0 = VCO frequency incorrect or unlocked

**$\overline{\text{ACQ}}$  — Acquisition Mode Bit**

When the AUTO bit is set,  $\overline{\text{ACQ}}$  is a read-only bit that indicates whether the PLL is in acquisition mode or tracking mode. When the AUTO bit is clear,  $\overline{\text{ACQ}}$  is a read/write bit that controls whether the PLL is in acquisition or tracking mode.

In automatic bandwidth control mode (AUTO = 1), the last-written value from manual operation is stored in a temporary location and is recovered when manual operation resumes. Reset clears this bit, enabling acquisition mode.

- 1 = Tracking mode
- 0 = Acquisition mode

Clock Generator Module (CGM)

8.6.3 PLL Multiplier Select Registers

The PLL multiplier select registers (PMSH and PMSL) contain the programming information for the modulo feedback divider.

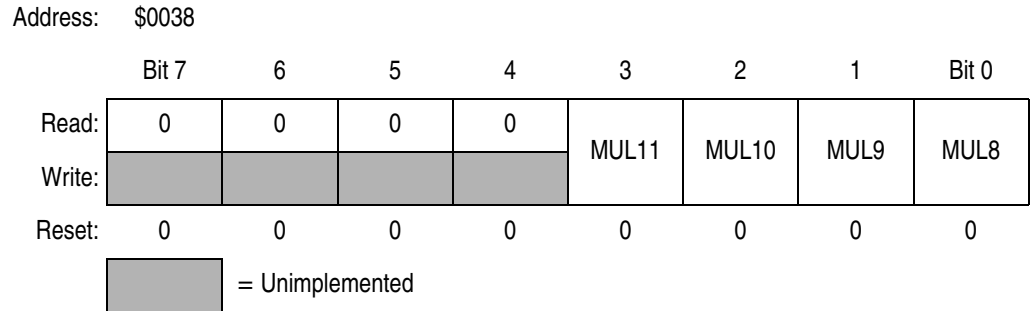


Figure 8-6. PLL Multiplier Select Register High (PMSH)

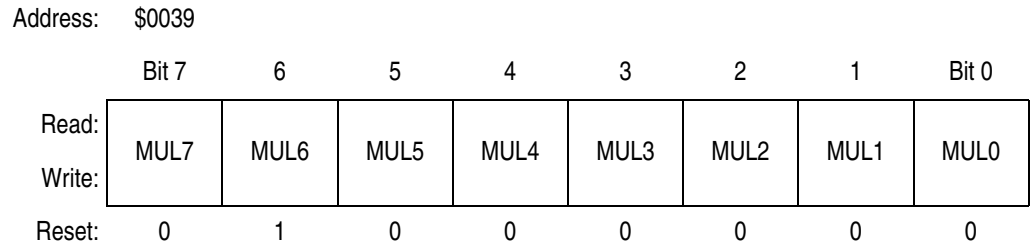


Figure 8-7. PLL Multiplier Select Register Low (PMSL)

MUL[11:0] — Multiplier Select Bits

These read/write bits control the modulo feedback divider that selects the VCO frequency multiplier N. (See [8.4.3 PLL Circuits](#) and [8.4.6 Programming the PLL](#).) A value of \$0000 in the multiplier select registers configure the modulo feedback divider the same as a value of \$0001. Reset initializes the registers to \$0040 for a default multiply value of 64.

**NOTE:** The multiplier select bits have built-in protection such that they cannot be written when the PLL is on (PLLON = 1).

### 8.6.4 PLL VCO Range Select Register

The PLL VCO range select register (PMRS) contains the programming information required for the hardware configuration of the VCO.

Address: \$003A

	Bit 7	6	5	4	3	2	1	Bit 0
Read:	VRS7	VRS6	VRS5	VRS4	VRS3	VRS2	VRS1	VRS0
Write:								
Reset:	0	1	0	0	0	0	0	0

**Figure 8-8. PLL VCO Range Select Register (PMRS)**

#### VRS[7:0] — VCO Range Select Bits

These read/write bits control the hardware center-of-range linear multiplier L which, in conjunction with E (See [8.4.3 PLL Circuits](#), [8.4.6 Programming the PLL](#), and [8.6.1 PLL Control Register](#).), controls the hardware center-of-range frequency,  $f_{VRS}$ . VRS[7:0] cannot be written when the PLLON bit in the PCTL is set. (See [8.4.7 Special Programming Exceptions](#).) A value of \$00 in the VCO range select register disables the PLL and clears the BCS bit in the PLL control register (PCTL). (See [8.4.8 Base Clock Selector Circuit](#) and [8.4.7 Special Programming Exceptions](#).) Reset initializes the register to \$40 for a default range multiply value of 64.

**NOTE:** *The VCO range select bits have built-in protection such that they cannot be written when the PLL is on (PLLON = 1) and such that the VCO clock cannot be selected as the source of the base clock (BCS = 1) if the VCO range select bits are all clear.*

*The PLL VCO range select register must be programmed correctly. Incorrect programming can result in failure of the PLL to achieve lock.*

8.6.5 PLL Reference Divider Select Register

The PLL reference divider select register (PMDS) contains the programming information for the modulo reference divider.

Address: \$003B

	Bit 7	6	5	4	3	2	1	Bit 0
Read:	0	0	0	0	RDS3	RDS2	RDS1	RDS0
Write:								
Reset:	0	0	0	0	0	0	0	1


 = Unimplemented

Figure 8-9. PLL Reference Divider Select Register (PMDS)

RDS[3:0] — Reference Divider Select Bits

These read/write bits control the modulo reference divider that selects the reference division factor, R. (See [8.4.3 PLL Circuits](#) and [8.4.6 Programming the PLL](#).) RDS[3:0] cannot be written when the PLLON bit in the PCTL is set. A value of \$00 in the reference divider select register configures the reference divider the same as a value of \$01. (See [8.4.7 Special Programming Exceptions](#).) Reset initializes the register to \$01 for a default divide value of 1.

**NOTE:** *The reference divider select bits have built-in protection such that they cannot be written when the PLL is on (PLLON = 1).*

**NOTE:** *The default divide value of 1 is recommended for all applications.*

## 8.7 Interrupts

When the AUTO bit is set in the PLL bandwidth control register (PBWC), the PLL can generate a CPU interrupt request every time the LOCK bit changes state. The PLLIE bit in the PLL control register (PCTL) enables CPU interrupts from the PLL. PLLF, the interrupt flag in the PCTL, becomes set whether interrupts are enabled or not. When the AUTO bit is clear, CPU interrupts from the PLL are disabled and PLLF reads as logic 0.

Software should read the LOCK bit after a PLL interrupt request to see if the request was due to an entry into lock or an exit from lock. When the PLL enters lock, the divided VCO clock, CGMPCLK, divided by two can be selected as the CGMOUT source by setting BCS in the PCTL. When the PLL exits lock, the VCO clock frequency is corrupt, and appropriate precautions should be taken. If the application is not frequency sensitive, interrupts should be disabled to prevent PLL interrupt service routines from impeding software performance or from exceeding stack limitations.

**NOTE:** *Software can select the CGMPCLK divided by two as the CGMOUT source even if the PLL is not locked (LOCK = 0). Therefore, software should make sure the PLL is locked before setting the BCS bit.*

## 8.8 Special Modes

The WAIT instruction puts the MCU in low power-consumption standby modes.

### 8.8.1 Wait Mode

The WAIT instruction does not affect the CGM. Before entering wait mode, software can disengage and turn off the PLL by clearing the BCS and PLLON bits in the PLL control register (PCTL) to save power. Less power-sensitive applications can disengage the PLL without turning it off, so that the PLL clock is immediately available at WAIT exit. This would be the case also when the PLL is to wake the MCU from wait mode, such as when the PLL is first enabled and waiting for LOCK or LOCK is lost.

### 8.8.2 Stop Mode

If the oscillator stop mode enable bit (STOP\_XCLKEN in CONFIG2 register) is configured to disabled the oscillator in stop mode, then the STOP instruction disables the CGM (oscillator and phase locked loop) and holds low all CGM outputs (CGMOUT, CGMVCLK, CGMPCLK, and CGMINT).

If the STOP instruction is executed with the divided VCO clock, CGMPCLK, divided by two driving CGMOUT, the PLL automatically clears the BCS bit in the PLL control register (PCTL), thereby selecting the oscillator clock, CGMXCLK, divided by two as the source of CGMOUT. When the MCU recovers from STOP, the crystal clock divided by two drives CGMOUT and BCS remains clear.

If the oscillator stop mode enable bit is configured for continuous oscillator operation in stop mode, then the phase locked loop is shut off but the CGMXCLK will continue to drive the SIM and other MCU sub-systems.

### 8.8.3 CGM During Break Interrupts

The system integration module (SIM) controls whether status bits in other modules can be cleared during the break state. The BCFE bit in the SIM break flag control register (SBFCR) enables software to clear status bits during the break state. (See [9.8.3 SIM Break Flag Control Register](#).)

To allow software to clear status bits during a break interrupt, write a logic 1 to the BCFE bit. If a status bit is cleared during the break state, it remains cleared when the MCU exits the break state.

To protect the PLLF bit during the break state, write a logic 0 to the BCFE bit. With BCFE at logic 0 (its default state), software can read and write the PLL control register during the break state without affecting the PLLF bit.

## 8.9 Acquisition/Lock Time Specifications

The acquisition and lock times of the PLL are, in many applications, the most critical PLL design parameters. Proper design and use of the PLL ensures the highest stability and lowest acquisition/lock times.

### 8.9.1 Acquisition/Lock Time Definitions

Typical control systems refer to the acquisition time or lock time as the reaction time, within specified tolerances, of the system to a step input. In a PLL, the step input occurs when the PLL is turned on or when it suffers a noise hit. The tolerance is usually specified as a percent of the step input or when the output settles to the desired value plus or minus a percent of the frequency change. Therefore, the reaction time is constant in this definition, regardless of the size of the step input. For example, consider a system with a 5 percent acquisition time tolerance. If a command instructs the system to change from 0Hz to 1 MHz, the acquisition time is the time taken for the frequency to reach  $1\text{ MHz} \pm 50\text{kHz}$ .  $50\text{kHz} = 5\%$  of the 1 MHz step input. If the system is operating at 1 MHz and suffers a  $-100\text{kHz}$  noise hit, the acquisition time is the time taken to return from 900kHz to  $1\text{ MHz} \pm 5\text{kHz}$ .  $5\text{kHz} = 5\%$  of the 100kHz step input.

Other systems refer to acquisition and lock times as the time the system takes to reduce the error between the actual output and the desired output to within specified tolerances. Therefore, the acquisition or lock time varies according to the original error in the output. Minor errors may not even be registered. Typical PLL applications prefer to use this definition because the system requires the output frequency to be within a certain tolerance of the desired frequency regardless of the size of the initial error.

### 8.9.2 Parametric Influences on Reaction Time

Acquisition and lock times are designed to be as short as possible while still providing the highest possible stability. These reaction times are not constant, however. Many factors directly and indirectly affect the acquisition time.

The most critical parameter which affects the reaction times of the PLL is the reference frequency,  $f_{RDV}$ . This frequency is the input to the phase detector and controls how often the PLL makes corrections. For stability, the corrections must be small compared to the desired frequency, so several corrections are required to reduce the frequency error.

Therefore, the slower the reference the longer it takes to make these corrections. This parameter is under user control via the choice of crystal frequency  $f_{XCLK}$  and the R value programmed in the reference divider. (See [8.4.3 PLL Circuits](#), [8.4.6 Programming the PLL](#), and [8.6.5 PLL Reference Divider Select Register](#).)

Another critical parameter is the external filter network. The PLL modifies the voltage on the VCO by adding or subtracting charge from capacitors in this network. Therefore, the rate at which the voltage changes for a given frequency error (thus change in charge) is proportional to the capacitance. The size of the capacitor also is related to the stability of the PLL. If the capacitor is too small, the PLL cannot make small enough adjustments to the voltage and the system cannot lock. If the capacitor is too large, the PLL may not be able to adjust the voltage in a reasonable time. (See [8.9.3 Choosing a Filter](#).)

Also important is the operating voltage potential applied to  $V_{DDA}$ . The power supply potential alters the characteristics of the PLL. A fixed value is best. Variable supplies, such as batteries, are acceptable if they vary within a known range at very slow speeds. Noise on the power supply is not acceptable, because it causes small frequency errors which continually change the acquisition time of the PLL.

Temperature and processing also can affect acquisition time because the electrical characteristics of the PLL change. The part operates as specified as long as these influences stay within the specified limits. External factors, however, can cause drastic changes in the operation of the PLL. These factors include noise injected into the PLL through the filter capacitor, filter capacitor leakage, stray impedances on the circuit board, and even humidity or circuit board contamination.



### 8.9.3 Choosing a Filter

As described in [8.9.2 Parametric Influences on Reaction Time](#), the external filter network is critical to the stability and reaction time of the PLL. The PLL is also dependent on reference frequency and supply voltage.

Either of the filter networks in [Figure 8-10](#) is recommended when using a 32.768kHz reference clock (CGMRCLK). [Figure 8-10 \(a\)](#) is used for applications requiring better stability. [Figure 8-10 \(b\)](#) is used in low-cost applications where stability is not critical.

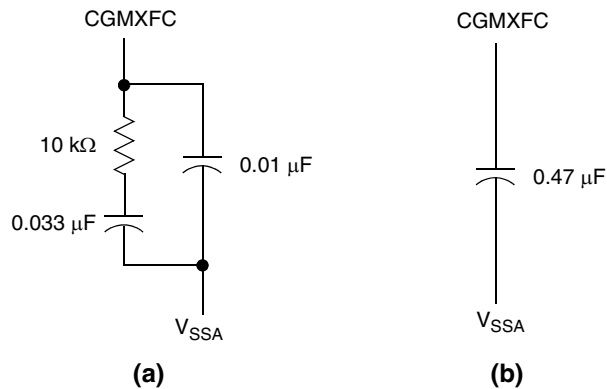


Figure 8-10. PLL Filter



## Section 9. System Integration Module (SIM)

### 9.1 Contents

9.2	Introduction . . . . .	140
9.3	SIM Bus Clock Control and Generation . . . . .	142
9.3.1	Bus Timing . . . . .	143
9.3.2	Clock Start-up from POR or LVI Reset. . . . .	143
9.3.3	Clocks in Stop Mode and Wait Mode . . . . .	144
9.4	Reset and System Initialization. . . . .	144
9.4.1	External Pin Reset . . . . .	145
9.4.2	Active Resets from Internal Sources . . . . .	145
9.4.2.1	Power-On Reset . . . . .	146
9.4.2.2	Computer Operating Properly (COP) Reset. . . . .	147
9.4.2.3	Illegal Opcode Reset . . . . .	148
9.4.2.4	Illegal Address Reset. . . . .	148
9.4.2.5	Low-Voltage Inhibit (LVI) Reset . . . . .	148
9.4.2.6	Monitor Mode Entry Module Reset (MODRST) . . . . .	148
9.5	SIM Counter . . . . .	149
9.5.1	SIM Counter During Power-On Reset . . . . .	149
9.5.2	SIM Counter During Stop Mode Recovery . . . . .	149
9.5.3	SIM Counter and Reset States. . . . .	149
9.6	Exception Control . . . . .	150
9.6.1	Interrupts . . . . .	150
9.6.1.1	Hardware Interrupts . . . . .	152
9.6.1.2	SWI Instruction. . . . .	153
9.6.1.3	Interrupt Status Registers . . . . .	153
9.6.1.4	Interrupt Status Register 1 . . . . .	153
9.6.1.5	Interrupt Status Register 2 . . . . .	155
9.6.1.6	Interrupt Status Register 3 . . . . .	155
9.6.2	Reset . . . . .	156
9.6.3	Break Interrupts . . . . .	156

9.6.4 Status Flag Protection in Break Mode .....156

9.7 Low-Power Modes .....157

9.7.1 Wait Mode .....157

9.7.2 Stop Mode .....158

9.8 SIM Registers .....159

9.8.1 SIM Break Status Register .....160

9.8.2 SIM Reset Status Register .....161

9.8.3 SIM Break Flag Control Register .....162

## 9.2 Introduction

This section describes the system integration module (SIM). Together with the CPU, the SIM controls all MCU activities. A block diagram of the SIM is shown in **Figure 9-1**. **Table 9-1** is a summary of the SIM input/output (I/O) registers. The SIM is a system state controller that coordinates CPU and exception timing. The SIM is responsible for:

- Bus clock generation and control for CPU and peripherals:
  - Stop/wait/reset/break entry and recovery
  - Internal clock control
- Master reset control, including power-on reset (POR) and COP timeout
- Interrupt control:
  - Acknowledge timing
  - Arbitration control timing
  - Vector address generation
- CPU enable/disable timing
- Modular architecture expandable to 128 interrupt sources

**Table 9-1** shows the internal signal names used in this section.

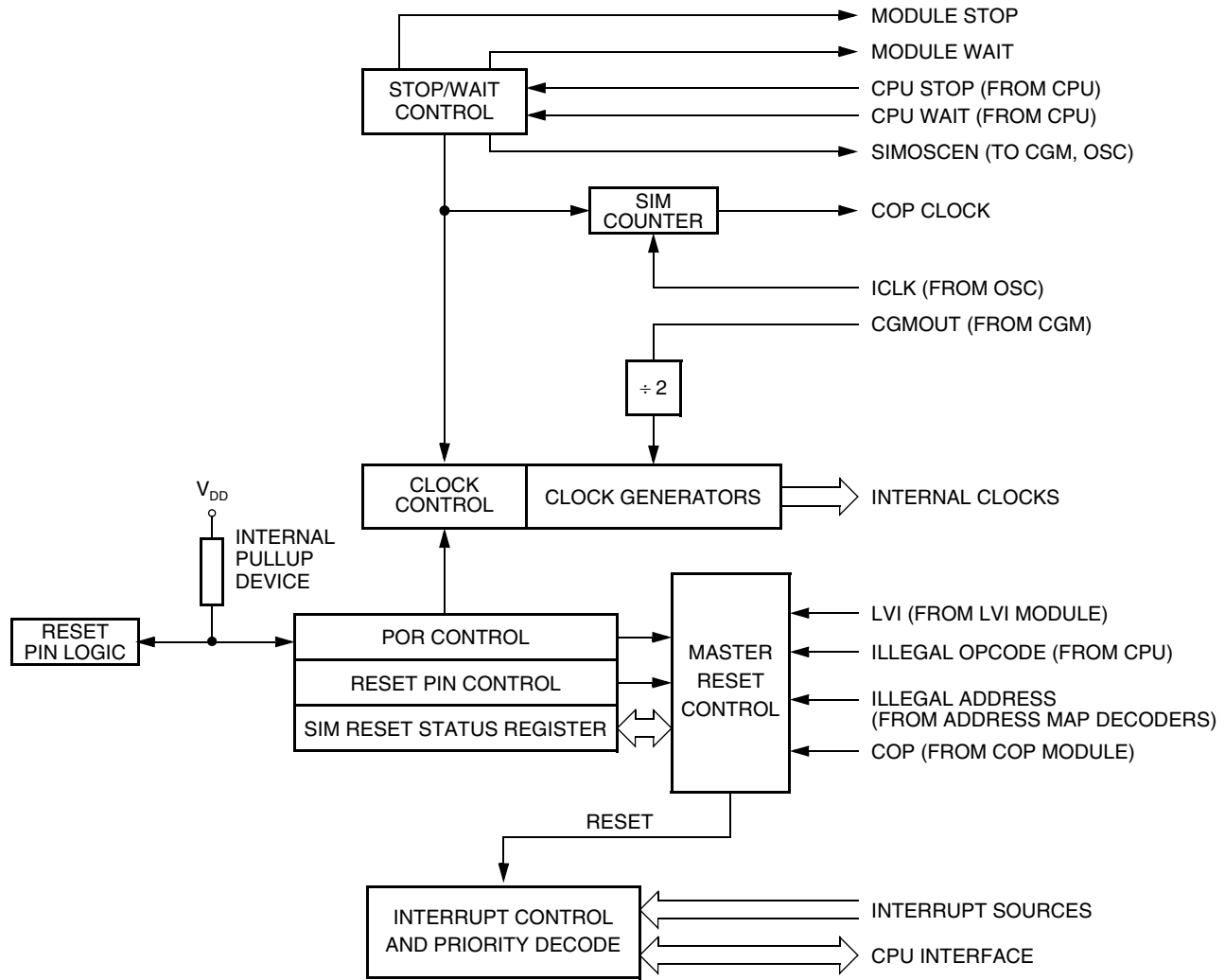


Figure 9-1. SIM Block Diagram

Table 9-1. Signal Name Conventions

Signal Name	Description
ICLK	Internal RC oscillator clock
CGMXCLK	Buffered version of OSC1 from the oscillator module
CGMPCLK	The divided PLL output
CGMOUT	PLL-based or oscillator-based clock output from CGM module (Bus clock = CGMOUT ÷ 2)
IAB	Internal address bus
IDB	Internal data bus
PORRST	Signal from the power-on reset module to the SIM
IRST	Internal reset signal
R/W	Read/write signal

System Integration Module (SIM)

Addr.	Register Name	Bit 7	6	5	4	3	2	1	Bit 0	
\$FE00	SIM Break Status Register (SBSR)	Read:	R	R	R	R	R	SBSW	R	
		Write:						Note		
		Reset:								0
Note: Writing a logic 0 clears SBSW.										
\$FE01	SIM Reset Status Register (SRSR)	Read:	POR	PIN	COP	ILOP	ILAD	0	LVI	0
		Write:								
		POR:	1	0	0	0	0	0	0	0
\$FE03	SIM Break Flag Control Register (SBFCR)	Read:	BCFE	R	R	R	R	R	R	R
		Write:								
		Reset:	0							
\$FE04	Interrupt Status Register 1 (INT1)	Read:	IF6	IF5	IF4	IF3	IF2	IF1	0	0
		Write:	R	R	R	R	R	R	R	R
		Reset:	0	0	0	0	0	0	0	0
\$FE05	Interrupt Status Register 2 (INT2)	Read:	IF14	IF13	IF12	IF11	IF10	IF9	IF8	IF7
		Write:	R	R	R	R	R	R	R	R
		Reset:	0	0	0	0	0	0	0	0
\$FE06	Interrupt Status Register 3 (INT3)	Read:	0	0	0	0	IF18	IF17	IF16	IF15
		Write:	R	R	R	R	R	R	R	R
		Reset:	0	0	0	0	0	0	0	0
			= Unimplemented			= Reserved				

Figure 9-2. SIM I/O Register Summary

9.3 SIM Bus Clock Control and Generation

The bus clock generator provides system clock signals for the CPU and peripherals on the MCU. The system clocks are generated from an incoming clock, CGMOUT, as shown in [Figure 9-3](#). This clock can come from either the oscillator module or from the on-chip PLL. (See [Section 8. Clock Generator Module \(CGM\)](#).)

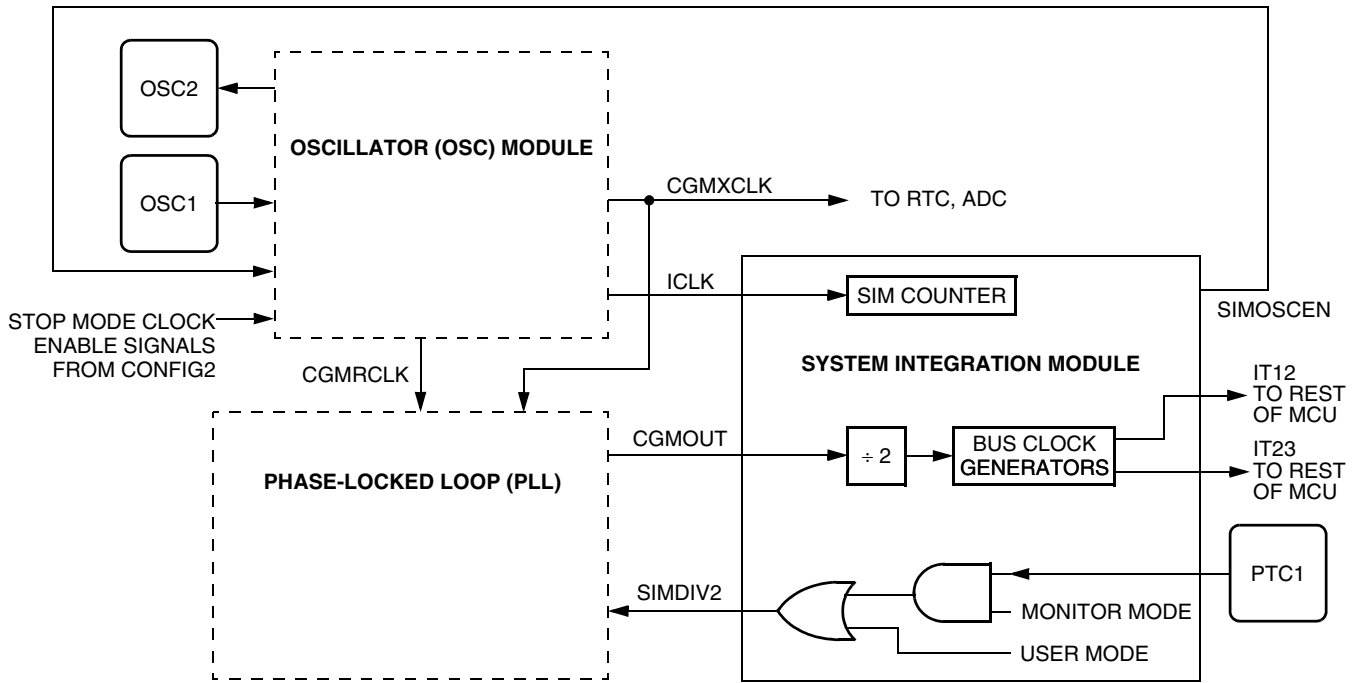


Figure 9-3. CGM Clock Signals

### 9.3.1 Bus Timing

In user mode, the internal bus frequency is either the oscillator output (CGMXCLK) divided by four, CGMXCLK divided by two, or the PLL output (CGMPCLK) divided by four.

### 9.3.2 Clock Start-up from POR or LVI Reset

When the power-on reset module or the low-voltage inhibit module generates a reset, the clocks to the CPU and peripherals are inactive and held in an inactive phase until after the 4096 ICLK cycle POR timeout has completed. The  $\overline{RST}$  pin is driven low by the SIM during this entire period. The IBUS clocks start upon completion of the timeout.

### 9.3.3 Clocks in Stop Mode and Wait Mode

Upon exit from stop mode by an interrupt, break, or reset, the SIM allows ICLK to clock the SIM counter. The CPU and peripheral clocks do not become active until after the stop delay timeout. This timeout is selectable as 4096 or 32 ICLK cycles. (See [9.7.2 Stop Mode](#).)

In wait mode, the CPU clocks are inactive. The SIM also produces two sets of clocks for other modules. Refer to the wait mode subsection of each module to see if the module is active or inactive in wait mode. Some modules can be programmed to be active in wait mode.

## 9.4 Reset and System Initialization

The MCU has these reset sources:

- Power-on reset module (POR)
- External reset pin ( $\overline{\text{RST}}$ )
- Computer operating properly module (COP)
- Low-voltage inhibit module (LVI)
- Illegal opcode
- Illegal address

All of these resets produce the vector \$FFFE:\$FFFF (\$FEFE:\$FEFF in monitor mode) and assert the internal reset signal (IRST). IRST causes all registers to be returned to their default values and all modules to be returned to their reset states.

An internal reset clears the SIM counter (see [9.5 SIM Counter](#)), but an external reset does not. Each of the resets sets a corresponding bit in the SIM reset status register (SRSR). (See [9.8 SIM Registers](#).)



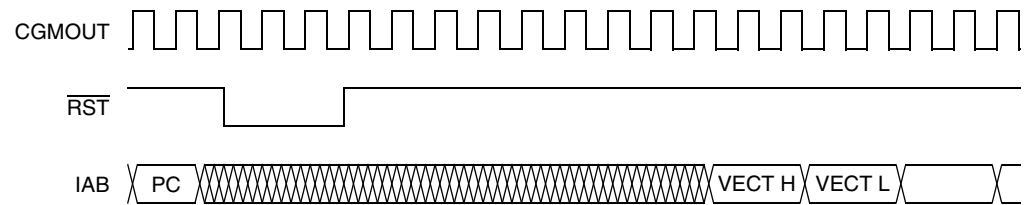
### 9.4.1 External Pin Reset

The  $\overline{\text{RST}}$  pin circuit includes an internal pull-up device. Pulling the asynchronous  $\overline{\text{RST}}$  pin low halts all processing. The PIN bit of the SIM reset status register (SRSR) is set as long as  $\overline{\text{RST}}$  is held low for a minimum of 67 ICLK cycles, assuming that neither the POR nor the LVI was the source of the reset. See [Table 9-2](#) for details.

[Figure 9-4](#) shows the relative timing.

**Table 9-2. PIN Bit Set Timing**

Reset Type	Number of Cycles Required to Set PIN
POR/LVI	4163 (4096 + 64 + 3)
All others	67 (64 + 3)



**Figure 9-4. External Reset Timing**

### 9.4.2 Active Resets from Internal Sources

All internal reset sources actively pull the  $\overline{\text{RST}}$  pin low for 32 ICLK cycles to allow resetting of external peripherals. The internal reset signal IRST continues to be asserted for an additional 32 cycles (see [Figure 9-5](#)). An internal reset can be caused by an illegal address, illegal opcode, COP timeout, LVI, or POR (see [Figure 9-6](#)).

**NOTE:** For LVI or POR resets, the SIM cycles through 4096 + 32 ICLK cycles during which the SIM forces the  $\overline{\text{RST}}$  pin low. The internal reset signal then follows the sequence from the falling edge of  $\overline{\text{RST}}$  shown in [Figure 9-5](#).

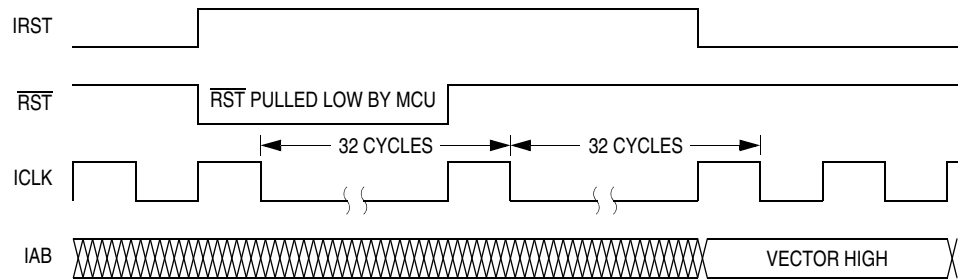


Figure 9-5. Internal Reset Timing

The COP reset is asynchronous to the bus clock.

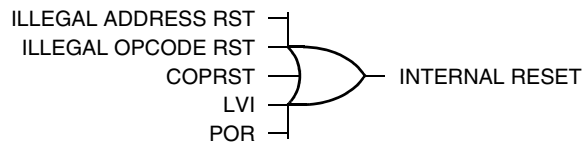


Figure 9-6. Sources of Internal Reset

The active reset feature allows the part to issue a reset to peripherals and other chips within a system built around the MCU.

9.4.2.1 Power-On Reset

When power is first applied to the MCU, the power-on reset module (POR) generates a pulse to indicate that power-on has occurred. The external reset pin ( $\overline{RST}$ ) is held low while the SIM counter counts out 4096 + 32 ICLK cycles. Thirty-two ICLK cycles later, the CPU and memories are released from reset to allow the reset vector sequence to occur.

At power-on, these events occur:

- A POR pulse is generated.
- The internal reset signal is asserted.
- The SIM enables CGMOUT.
- Internal clocks to the CPU and modules are held inactive for 4096 ICLK cycles to allow stabilization of the oscillator.
- The  $\overline{RST}$  pin is driven low during the oscillator stabilization time.
- The POR bit of the SIM reset status register (SRSR) is set and all other bits in the register are cleared.

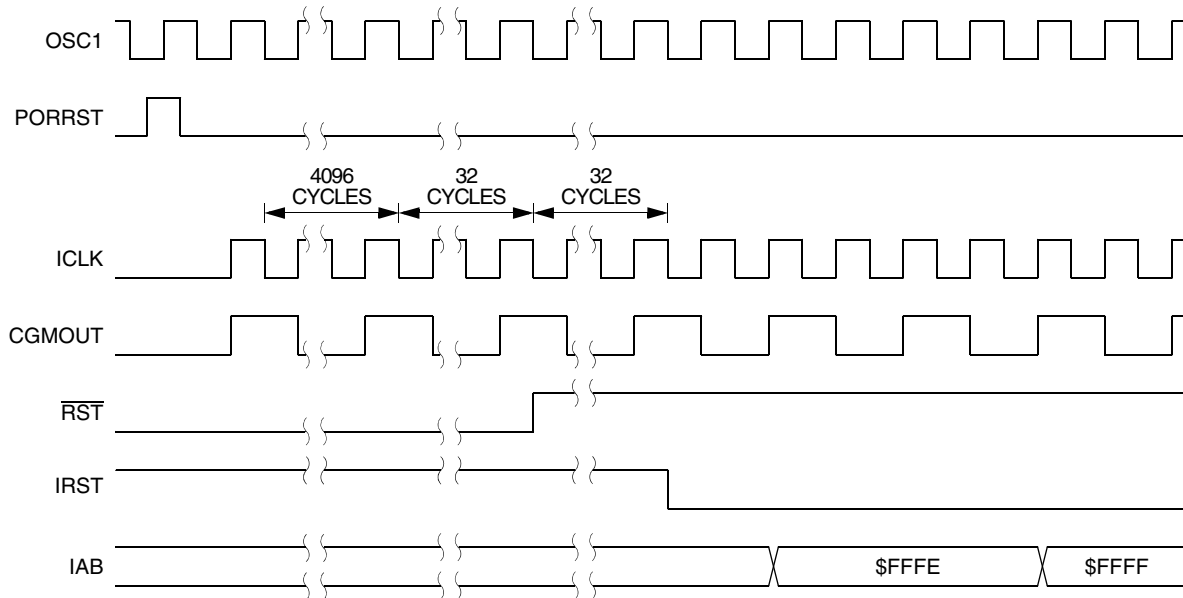


Figure 9-7. POR Recovery

9.4.2.2 Computer Operating Properly (COP) Reset

An input to the SIM is reserved for the COP reset signal. The overflow of the COP counter causes an internal reset and sets the COP bit in the SIM reset status register (SRSR). The SIM actively pulls down the  $\overline{RST}$  pin for all internal reset sources.

To prevent a COP module timeout, write any value to location \$FFFF. Writing to location \$FFFF clears the COP counter and bits 12 through 5 of the SIM counter. The SIM counter output, which occurs at least every  $2^{13} - 2^4$  ICLK cycles, drives the COP counter. The COP should be serviced as soon as possible out of reset to guarantee the maximum amount of time before the first timeout.

The COP module is disabled if the  $\overline{RST}$  pin or the  $\overline{IRQ}$  pin is held at  $V_{TST}$  while the MCU is in monitor mode. The COP module can be disabled only through combinational logic conditioned with the high voltage signal on the  $\overline{RST}$  or the  $\overline{IRQ}$  pin. This prevents the COP from becoming disabled as a result of external noise. During a break state,  $V_{TST}$  on the  $\overline{RST}$  pin disables the COP module.

*9.4.2.3 Illegal Opcode Reset*

The SIM decodes signals from the CPU to detect illegal instructions. An illegal instruction sets the ILOP bit in the SIM reset status register (SRSR) and causes a reset.

If the stop enable bit, STOP, in the mask option register is logic 0, the SIM treats the STOP instruction as an illegal opcode and causes an illegal opcode reset. The SIM actively pulls down the  $\overline{\text{RST}}$  pin for all internal reset sources.

*9.4.2.4 Illegal Address Reset*

An opcode fetch from an unmapped address generates an illegal address reset. The SIM verifies that the CPU is fetching an opcode prior to asserting the ILAD bit in the SIM reset status register (SRSR) and resetting the MCU. A data fetch from an unmapped address does not generate a reset. The SIM actively pulls down the  $\overline{\text{RST}}$  pin for all internal reset sources.

*9.4.2.5 Low-Voltage Inhibit (LVI) Reset*

The low-voltage inhibit module (LVI) asserts its output to the SIM when the  $V_{\text{DD}}$  voltage falls to the LVI trip falling voltage,  $V_{\text{TRIPF}}$ . The LVI bit in the SIM reset status register (SRSR) is set, and the external reset pin ( $\overline{\text{RST}}$ ) is held low while the SIM counter counts out  $4096 + 32$  ICLK cycles. Thirty-two ICLK cycles later, the CPU is released from reset to allow the reset vector sequence to occur. The SIM actively pulls down the  $\overline{\text{RST}}$  pin for all internal reset sources.

*9.4.2.6 Monitor Mode Entry Module Reset (MODRST)*

The monitor mode entry module reset (MODRST) asserts its output to the SIM when monitor mode is entered in the condition where the reset vectors are blank (\$FF). (See [Section 10. Monitor ROM \(MON\)](#).) When MODRST gets asserted, an internal reset occurs. The SIM actively pulls down the  $\overline{\text{RST}}$  pin for all internal reset sources.

## 9.5 SIM Counter

The SIM counter is used by the power-on reset module (POR) and in stop mode recovery to allow the oscillator time to stabilize before enabling the internal bus (IBUS) clocks. The SIM counter also serves as a prescaler for the computer operating properly module (COP). The SIM counter overflow supplies the clock for the COP module. The SIM counter is 12 bits long and is clocked by the falling edge of ICLK.

### 9.5.1 SIM Counter During Power-On Reset

The power-on reset module (POR) detects power applied to the MCU. At power-on, the POR circuit asserts the signal PORRST. Once the SIM is initialized, it enables the clock generation module (CGM) to drive the bus clock state machine.

### 9.5.2 SIM Counter During Stop Mode Recovery

The SIM counter also is used for stop mode recovery. The STOP instruction clears the SIM counter. After an interrupt, break, or reset, the SIM senses the state of the short stop recovery bit, SSREC, in the configuration register 1 (CONFIG1). If the SSREC bit is a logic 1, then the stop recovery is reduced from the normal delay of 4096 ICLK cycles down to 32 ICLK cycles. This is ideal for applications using canned oscillators that do not require long start-up times from stop mode. External crystal applications should use the full stop recovery time, that is, with SSREC cleared.

### 9.5.3 SIM Counter and Reset States

External reset has no effect on the SIM counter. (See [9.7.2 Stop Mode](#) for details.) The SIM counter is free-running after all reset states. (See [9.4.2 Active Resets from Internal Sources](#) for counter control and internal reset recovery sequences.)

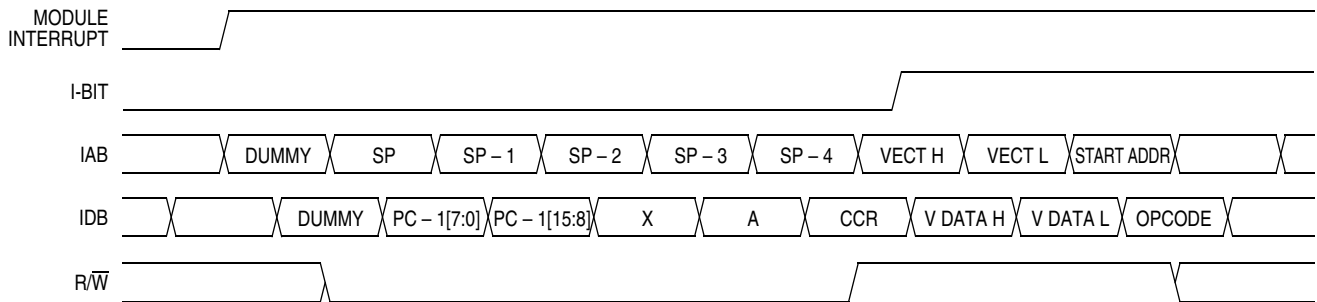
## 9.6 Exception Control

Normal, sequential program execution can be changed in three different ways:

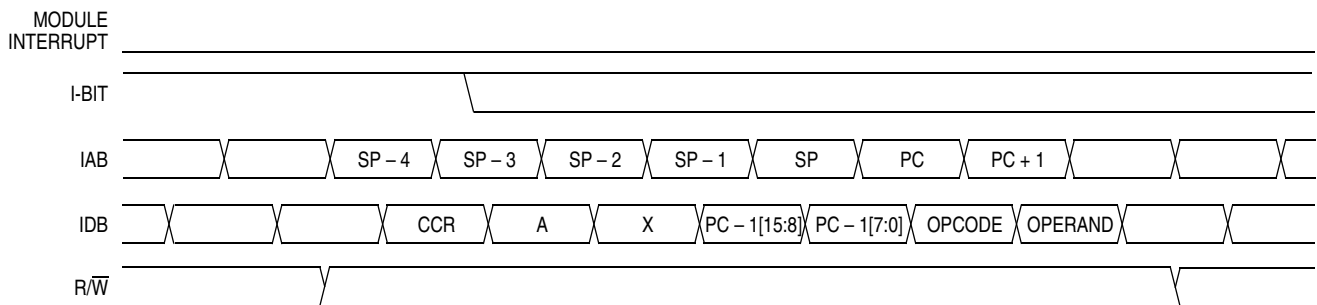
- Interrupts:
  - Maskable hardware CPU interrupts
  - Non-maskable software interrupt instruction (SWI)
- Reset
- Break interrupts

### 9.6.1 Interrupts

At the beginning of an interrupt, the CPU saves the CPU register contents on the stack and sets the interrupt mask (I bit) to prevent additional interrupts. At the end of an interrupt, the RTI instruction recovers the CPU register contents from the stack so that normal processing can resume. **Figure 9-8** shows interrupt entry timing, and **Figure 9-9** shows interrupt recovery timing.

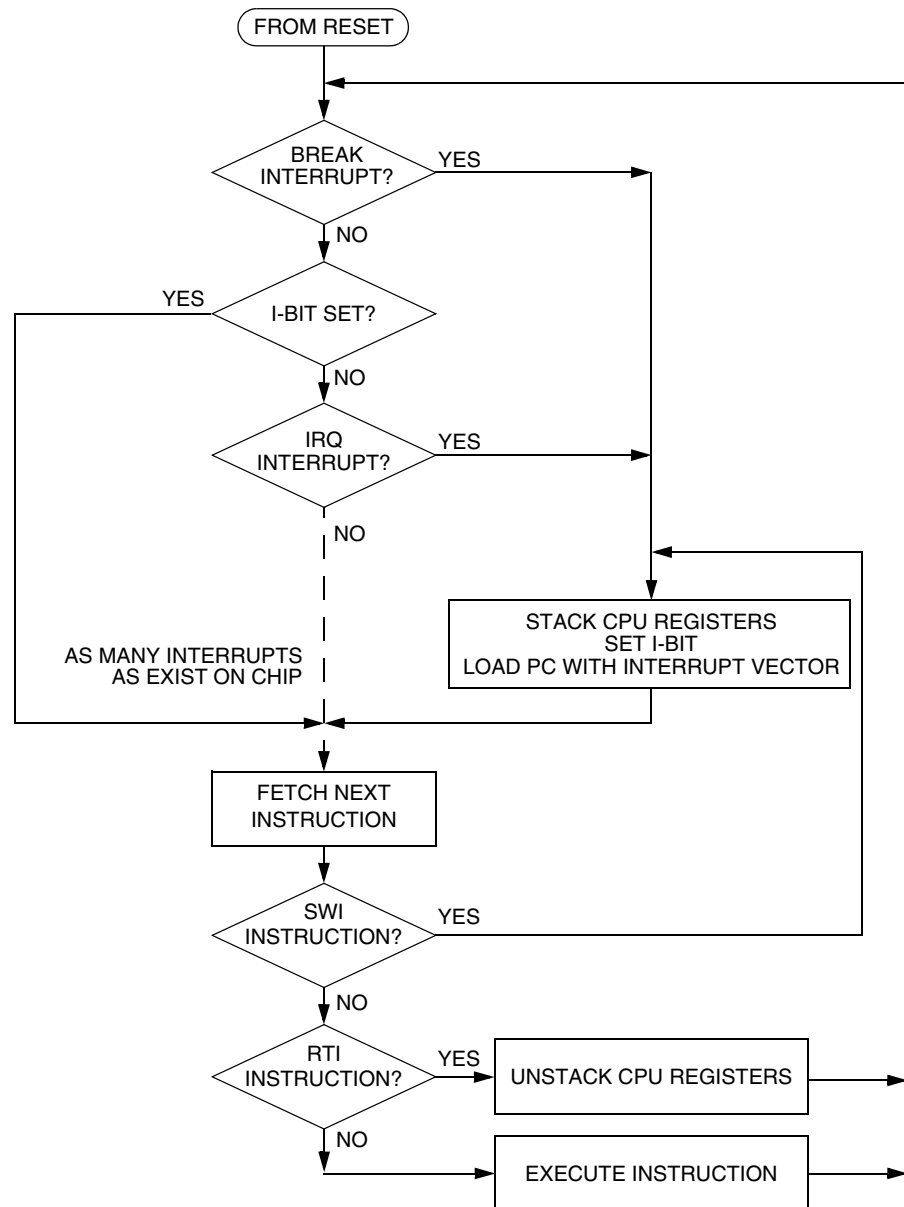


**Figure 9-8. Interrupt Entry Timing**



**Figure 9-9. Interrupt Recovery Timing**

Interrupts are latched, and arbitration is performed in the SIM at the start of interrupt processing. The arbitration result is a constant that the CPU uses to determine which vector to fetch. Once an interrupt is latched by the SIM, no other interrupt can take precedence, regardless of priority, until the latched interrupt is serviced (or the I bit is cleared).  
(See [Figure 9-10.](#))

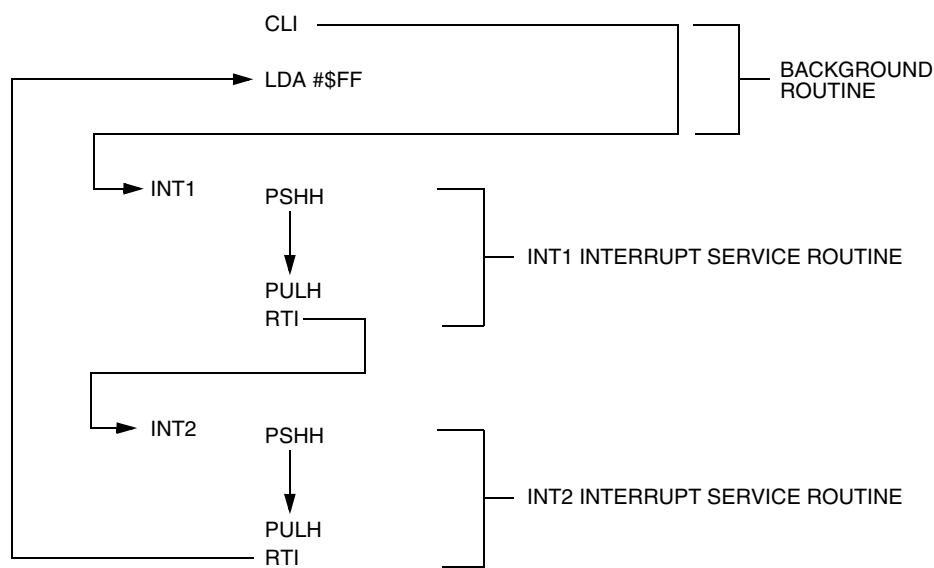


**Figure 9-10. Interrupt Processing**

9.6.1.1 Hardware Interrupts

A hardware interrupt does not stop the current instruction. Processing of a hardware interrupt begins after completion of the current instruction. When the current instruction is complete, the SIM checks all pending hardware interrupts. If interrupts are not masked (I bit clear in the condition code register) and if the corresponding interrupt enable bit is set, the SIM proceeds with interrupt processing; otherwise, the next instruction is fetched and executed.

If more than one interrupt is pending at the end of an instruction execution, the highest priority interrupt is serviced first. **Figure 9-11** demonstrates what happens when two interrupts are pending. If an interrupt is pending upon exit from the original interrupt service routine, the pending interrupt is serviced before the LDA instruction is executed.



**Figure 9-11. Interrupt Recognition Example**

The LDA opcode is prefetched by both the INT1 and INT2 RTI instructions. However, in the case of the INT1 RTI prefetch, this is a redundant operation.

**NOTE:** *To maintain compatibility with the M6805 Family, the H register is not pushed on the stack during interrupt entry. If the interrupt service routine modifies the H register or uses the indexed addressing mode, software should save the H register and then restore it prior to exiting the routine.*



9.6.1.2 SWI Instruction

The SWI instruction is a non-maskable instruction that causes an interrupt regardless of the state of the interrupt mask (I bit) in the condition code register.

**NOTE:** A software interrupt pushes PC onto the stack. A software interrupt does not push PC - 1, as a hardware interrupt does.

9.6.1.3 Interrupt Status Registers

The flags in the interrupt status registers identify maskable interrupt sources. Table 9-3 summarizes the interrupt sources and the interrupt status register flags that they set. The interrupt status registers can be useful for debugging.

9.6.1.4 Interrupt Status Register 1

Address: \$FE04

	Bit 7	6	5	4	3	2	1	Bit 0
Read:	IF6	IF5	IF4	IF3	IF2	IF1	0	0
Write:	R	R	R	R	R	R	R	R
Reset:	0	0	0	0	0	0	0	0

R = Reserved

**Figure 9-12. Interrupt Status Register 1 (INT1)**


IF6–IF1 — Interrupt Flags 6–1

These flags indicate the presence of interrupt requests from the sources shown in Table 9-3.

- 1 = Interrupt request present
- 0 = No interrupt request present

Bit 0 and Bit 1 — Always read 0

Table 9-3. Vector Addresses

Priority	INT Flag	Address	Vector
Lowest 	IF18	\$FFD8	Real Time Clock Vector (High)
		\$FFD9	Real Time Clock Vector (Low)
	IF17	\$FFDA	ADC Conversion Complete Vector (High)
		\$FFDB	ADC Conversion Complete Vector (Low)
	IF16	\$FFDC	Keyboard Vector (High)
		\$FFDD	Keyboard Vector (Low)
	IF15	\$FFDE	MMIIC Vector (High)
		\$FFDF	MMIIC Vector (Low)
	IF14	\$FFE0	SCI Transmit Vector (High)
		\$FFE1	SCI Transmit Vector (Low)
	IF13	\$FFE2	SCI Receive Vector (High)
		\$FFE3	SCI Receive Vector (Low)
	IF12	\$FFE4	SCI Error Vector (High)
		\$FFE5	SCI Error Vector (Low)
	IF11	\$FFE6	SPI Receive Vector (High)
		\$FFE7	SPI Receive Vector (Low)
	IF10	\$FFE8	SPI Transmit Vector (High)
		\$FFE9	SPI Transmit Vector (Low)
	IF9	\$FFEA	TIM2 Overflow Vector (High)
		\$FFEB	TIM2 Overflow Vector (Low)
	IF8	\$FFEC	TIM2 Channel 1 Vector (High)
		\$FFED	TIM2 Channel 1 Vector (Low)
	IF7	\$FFEE	TIM2 Channel 0 Vector (High)
		\$FFEF	TIM2 Channel 0 Vector (Low)
	IF6	\$FFF0	TIM1 Overflow Vector (High)
		\$FFF1	TIM1 Overflow Vector (Low)
	IF5	\$FFF2	TIM1 Channel 1 Vector (High)
		\$FFF3	TIM1 Channel 1 Vector (Low)
	IF4	\$FFF4	TIM1 Channel 0 Vector (High)
		\$FFF5	TIM1 Channel 0 Vector (Low)
	IF3	\$FFF6	PLL Vector (High)
		\$FFF7	PLL Vector (Low)
IF2	\$FFF8	LVI Vector (High)	
	\$FFF9	LVI Vector (Low)	
IF1	\$FFFA	IRQ Vector (High)	
	\$FFFB	IRQ Vector (Low)	
—	\$FFFC	SWI Vector (High)	
	\$FFFD	SWI Vector (Low)	
Highest	—	\$FFFE	Reset Vector (High)
		\$FFFF	Reset Vector (Low)

*9.6.1.5 Interrupt Status Register 2*

Address: \$FE05

	Bit 7	6	5	4	3	2	1	Bit 0
Read:	IF14	IF13	IF12	IF11	IF10	IF9	IF8	IF7
Write:	R	R	R	R	R	R	R	R
Reset:	0	0	0	0	0	0	0	0

R = Reserved

**Figure 9-13. Interrupt Status Register 2 (INT2)**

**IF14–IF7 — Interrupt Flags 14–7**

These flags indicate the presence of interrupt requests from the sources shown in [Table 9-3](#).

- 1 = Interrupt request present
- 0 = No interrupt request present

*9.6.1.6 Interrupt Status Register 3*

Address: \$FE06

	Bit 7	6	5	4	3	2	1	Bit 0
Read:	0	0	0	0	IF18	IF17	IF16	IF15
Write:	R	R	R	R	R	R	R	R
Reset:	0	0	0	0	0	0	0	0

R = Reserved

**Figure 9-14. Interrupt Status Register 3 (INT3)**

**IF18–IF15 — Interrupt Flags 18–15**

These flags indicate the presence of an interrupt request from the source shown in [Table 9-3](#).

- 1 = Interrupt request present
- 0 = No interrupt request present

### 9.6.2 Reset

All reset sources always have equal and highest priority and cannot be arbitrated.

### 9.6.3 Break Interrupts

The break module can stop normal program flow at a software-programmable break point by asserting its break interrupt output. (See [Section 23. Break Module \(BRK\)](#).) The SIM puts the CPU into the break state by forcing it to the SWI vector location. Refer to the break interrupt subsection of each module to see how each module is affected by the break state.

### 9.6.4 Status Flag Protection in Break Mode

The SIM controls whether status flags contained in other modules can be cleared during break mode. The user can select whether flags are protected from being cleared by properly initializing the break clear flag enable bit (BCFE) in the SIM break flag control register (SBFCR).

Protecting flags in break mode ensures that set flags will not be cleared while in break mode. This protection allows registers to be freely read and written during break mode without losing status flag information.

Setting the BCFE bit enables the clearing mechanisms. Once cleared in break mode, a flag remains cleared even when break mode is exited. Status flags with a 2-step clearing mechanism — for example, a read of one register followed by the read or write of another — are protected, even when the first step is accomplished prior to entering break mode. Upon leaving break mode, execution of the second step will clear the flag as normal.

## 9.7 Low-Power Modes

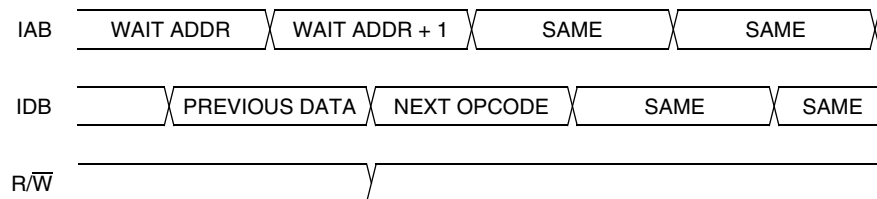
Executing the WAIT or STOP instruction puts the MCU in a low power-consumption mode for standby situations. The SIM holds the CPU in a non-clocked state. The operation of each of these modes is described in the following subsections. Both STOP and WAIT clear the interrupt mask (I) in the condition code register, allowing interrupts to occur.

### 9.7.1 Wait Mode

In wait mode, the CPU clocks are inactive while the peripheral clocks continue to run. **Figure 9-15** shows the timing for wait mode entry.

A module that is active during wait mode can wake up the CPU with an interrupt if the interrupt is enabled. Stacking for the interrupt begins one cycle after the WAIT instruction during which the interrupt occurred. In wait mode, the CPU clocks are inactive. Refer to the wait mode subsection of each module to see if the module is active or inactive in wait mode. Some modules can be programmed to be active in wait mode.

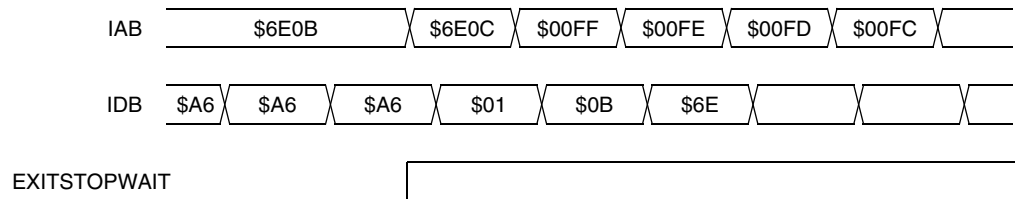
Wait mode also can be exited by a reset or break. A break interrupt during wait mode sets the SIM break stop/wait bit, SBSW, in the SIM break status register (SBSR). If the COP disable bit, COPD, in the mask option register is logic 0, then the computer operating properly module (COP) is enabled and remains active in wait mode.



NOTE: Previous data can be operand data or the WAIT opcode, depending on the last instruction.

**Figure 9-15. Wait Mode Entry Timing**

**Figure 9-16** and **Figure 9-17** show the timing for WAIT recovery.



NOTE: EXITSTOPWAIT =  $\overline{\text{RST}}$  pin OR CPU interrupt OR break interrupt

Figure 9-16. Wait Recovery from Interrupt or Break

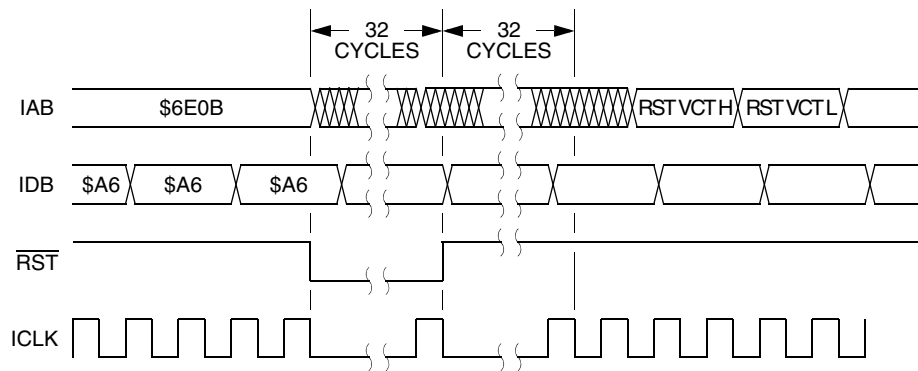


Figure 9-17. Wait Recovery from Internal Reset

### 9.7.2 Stop Mode

In stop mode, the SIM counter is reset and the system clocks are disabled. An interrupt request from a module can cause an exit from stop mode. Stacking for interrupts begins after the selected stop recovery time has elapsed. Reset or break also causes an exit from stop mode.

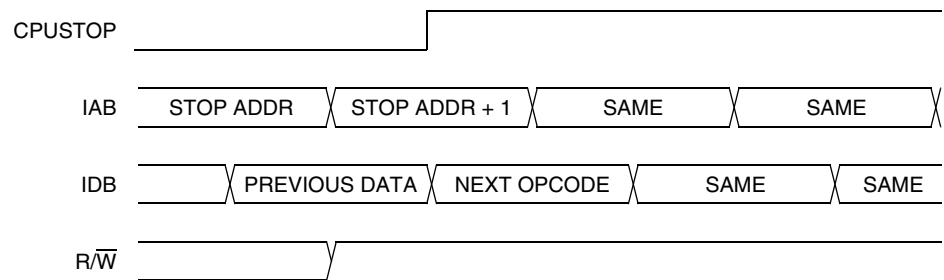
The SIM disables the clock generator module output (CGMOUT) in stop mode, stopping the CPU and peripherals. Stop recovery time is selectable using the SSREC bit in the configuration register 1 (CONFIG1). If SSREC is set, stop recovery is reduced from the normal delay of 4096 ICLK cycles down to 32. This is ideal for applications using canned oscillators that do not require long start-up times from stop mode.

**NOTE:** External crystal applications should use the full stop recovery time by clearing the SSREC bit.

A break interrupt during stop mode sets the SIM break stop/wait bit (SBSW) in the SIM break status register (SBSR).

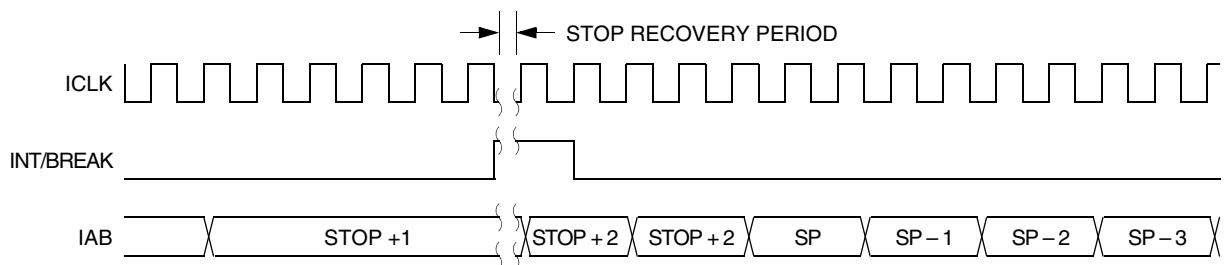
The SIM counter is held in reset from the execution of the STOP instruction until the beginning of stop recovery. It is then used to time the recovery period. **Figure 9-18** shows stop mode entry timing.

**NOTE:** To minimize stop current, all pins configured as inputs should be driven to a logic 1 or logic 0.



NOTE: Previous data can be operand data or the STOP opcode, depending on the last instruction.

**Figure 9-18. Stop Mode Entry Timing**



**Figure 9-19. Stop Mode Recovery from Interrupt or Break**

## 9.8 SIM Registers

The SIM has three memory-mapped registers:

- SIM Break Status Register (SBSR) — \$FE00
- SIM Reset Status Register (SRSR) — \$FE01
- SIM Break Flag Control Register (SBFCR) — \$FE03

9.8.1 SIM Break Status Register

The SIM break status register (SBSR) contains a flag to indicate that a break caused an exit from stop mode or wait mode.

Address: \$FE00

	Bit 7	6	5	4	3	2	1	Bit 0
Read:	R	R	R	R	R	R	SBSW	R
Write:							Note	
Reset:							0	

Note: Writing a logic 0 clears SBSW. 

R
---

 = Reserved

Figure 9-20. SIM Break Status Register (SBSR)

SBSW — Break Wait Bit

This status bit is set when a break interrupt causes an exit from wait mode or stop mode. Clear SBSW by writing a logic 0 to it. Reset clears SBSW.

- 1 = Stop mode or wait mode was exited by break interrupt
- 0 = Stop mode or wait mode was not exited by break interrupt

SBSW can be read within the break interrupt routine. The user can modify the return address on the stack by subtracting 1 from it. The following code is an example.

This code works if the H register has been pushed onto the stack in the break service routine software. This code should be executed at the end of the break service routine software.

```
HIBYTE EQU
LOBYTE EQU
    If not SBSW, do RTI
BRCLR  SBSW,SBSR, RETURN    ;See if wait mode or stop mode was exited by
                             ;break.
    TST   LOBYTE,SP         ;If RETURNLO is not zero,
BNE    DOLO                 ;then just decrement low byte.
DEC    HIBYTE,SP           ;Else deal with high byte, too.
DOLO   DEC   LOBYTE,SP     ;Point to WAIT/STOP opcode.
RETURN PULH                 ;Restore H register.
RTI
```



9.8.2 SIM Reset Status Register

This register contains six flags that show the source of the last reset provided all previous reset status bits have been cleared. Clear the SIM reset status register by reading it. A power-on reset sets the POR bit and clears all other bits in the register.

Address: \$FE01

	Bit 7	6	5	4	3	2	1	Bit 0
Read:	POR	PIN	COP	ILOP	ILAD	0	LVI	0
Write:								
Reset:	1	0	0	0	0	0	0	0


 = Unimplemented

Figure 9-21. SIM Reset Status Register (SRSR)

POR — Power-On Reset Bit

- 1 = Last reset caused by POR circuit
- 0 = Read of SRSR

PIN — External Reset Bit

- 1 = Last reset caused by external reset pin ( $\overline{RST}$ )
- 0 = POR or read of SRSR

COP — Computer Operating Properly Reset Bit

- 1 = Last reset caused by COP counter
- 0 = POR or read of SRSR

ILOP — Illegal Opcode Reset Bit

- 1 = Last reset caused by an illegal opcode
- 0 = POR or read of SRSR

ILAD — Illegal Address Reset Bit (opcode fetches only)

- 1 = Last reset caused by an opcode fetch from an illegal address
- 0 = POR or read of SRSR

LVI — Low-Voltage Inhibit Reset Bit

- 1 = Last reset caused by the LVI circuit
- 0 = POR or read of SRSR

9.8.3 SIM Break Flag Control Register

The SIM break control register contains a bit that enables software to clear status bits while the MCU is in a break state.

Address: \$FE03

	Bit 7	6	5	4	3	2	1	Bit 0
Read:	BCFE	R	R	R	R	R	R	R
Write:								
Reset:	0							

R
---

 = Reserved

Figure 9-22. SIM Break Flag Control Register (SBFCR)

BCFE — Break Clear Flag Enable Bit

This read/write bit enables software to clear status bits by accessing status registers while the MCU is in a break state. To clear status bits during the break state, the BCFE bit must be set.

- 1 = Status bits clearable during break
- 0 = Status bits not clearable during break

## Section 10. Monitor ROM (MON)

### 10.1 Contents

10.2	Introduction .....	164
10.3	Features .....	164
10.4	Functional Description .....	165
10.4.1	Entering Monitor Mode .....	167
10.4.2	Data Format .....	171
10.4.3	Break Signal .....	171
10.4.4	Baud Rate .....	171
10.4.5	Commands .....	172
10.5	Security .....	177
10.6	ROM-Resident Routines .....	179
10.6.1	PRGRNGE .....	181
10.6.2	ERARNGE .....	183
10.6.3	LDRNGE .....	184
10.6.4	MON_PRGRNGE .....	185
10.6.5	MON_ERARNGE .....	186
10.6.6	MON_LDRNGE .....	187
10.6.7	EE_WRITE .....	188
10.6.8	EE_READ .....	191

## 10.2 Introduction

This section describes the monitor ROM (MON) and the monitor mode entry methods. The monitor ROM allows complete testing of the MCU through a single-wire interface with a host computer. Monitor mode entry can be achieved without use of the higher test voltage,  $V_{TST}$ , as long as vector addresses \$FFFE and \$FFFF are blank, thus reducing the hardware requirements for in-circuit programming.

In addition, to simplify user coding, routines are also stored in the monitor ROM area for FLASH memory program /erase and EEPROM emulation.

## 10.3 Features

Features of the monitor ROM include:

- Normal user-mode pin functionality
- One pin dedicated to serial communication between monitor ROM and host computer
- Standard mark/space non-return-to-zero (NRZ) communication with host computer
- Execution of code in RAM or FLASH
- FLASH memory security feature<sup>1</sup>
- FLASH memory programming interface
- Enhanced PLL (phase-locked loop) option to allow use of external 32.768-kHz crystal to generate internal frequency of 2.4576 MHz
- 959 bytes monitor ROM code size (\$FC00–\$FDFF and \$FE10–\$FFCE)
- Monitor mode entry without high voltage,  $V_{TST}$ , if reset vector is blank (\$FFFE and \$FFFF contain \$FF)
- Standard monitor mode entry if high voltage,  $V_{TST}$ , is applied to  $\overline{IRQ}$
- Resident routines for in-circuit programming and EEPROM emulation

1. No security feature is absolutely secure. However, Motorola's strategy is to make reading or copying the FLASH difficult for unauthorized users.

## 10.4 Functional Description

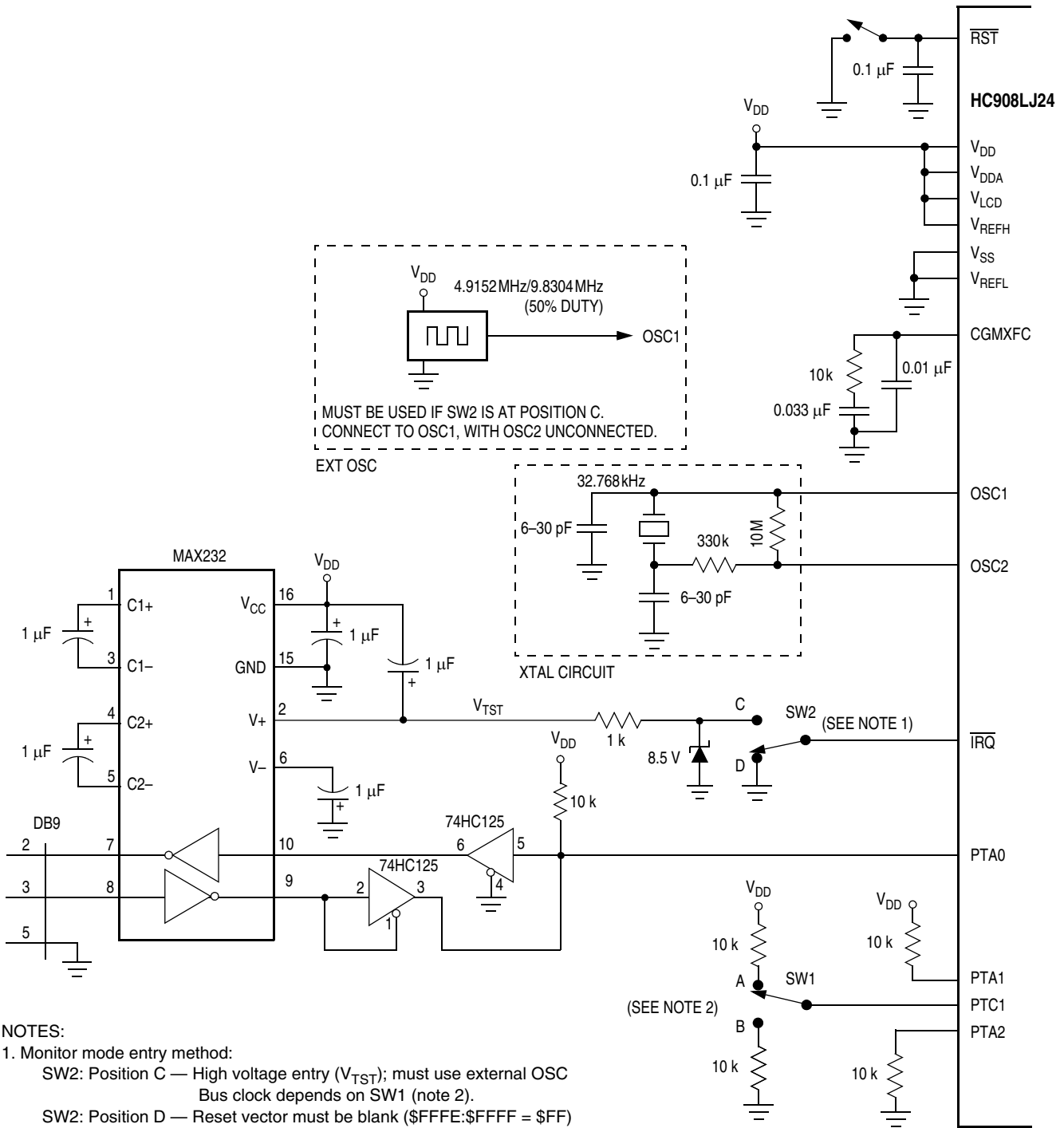
The monitor ROM receives and executes commands from a host computer. **Figure 10-1** shows an example circuit used to enter monitor mode and communicate with a host computer via a standard RS-232 interface.

Simple monitor commands can access any memory address. In monitor mode, the MCU can execute code downloaded into RAM by a host computer while most MCU pins retain normal operating mode functions. All communication between the host computer and the MCU is through the PTA0 pin. A level-shifting and multiplexing interface is required between PTA0 and the host computer. PTA0 is used in a wired-OR configuration and requires a pullup resistor.

The monitor code allows enabling the PLL to generate the internal clock, provided the reset vector is blank, when the device is being clocked by a low-frequency crystal. This entry method, which is enabled when  $\overline{\text{IRQ}}$  is held low out of reset, is intended to support serial communication/programming at 9600 baud in monitor mode by stepping up the external frequency (assumed to be 32.768 kHz) by a fixed amount to generate the desired internal frequency (2.4576 MHz). Since this feature is enabled only when  $\overline{\text{IRQ}}$  is held low out of reset, it cannot be used when the reset vector is non-zero because entry into monitor mode in this case requires  $V_{\text{TST}}$  on  $\overline{\text{IRQ}}$ .

Monitor ROM (MON)

Freescale Semiconductor, Inc.



NOTES:

1. Monitor mode entry method:
  - SW2: Position C — High voltage entry ( $V_{TST}$ ); must use external OSC  
Bus clock depends on SW1 (note 2).
  - SW2: Position D — Reset vector must be blank (\$FFFE:\$FFFF = \$FF)  
Bus clock = 2.4576MHz.
2. Affects high voltage entry to monitor mode only (SW2 at position C):
  - SW1: Position A — Bus clock =  $OSC1 \div 4$
  - SW1: Position B — Bus clock =  $OSC1 \div 2$
5. See [Table 24-4](#) for  $V_{TST}$  voltage level requirements.

Figure 10-1. Monitor Mode Circuit

### 10.4.1 Entering Monitor Mode

**Table 10-1** shows the pin conditions for entering monitor mode. As specified in the table, monitor mode may be entered after a POR and will allow communication at 9600 baud provided one of the following sets of conditions is met:

1. If \$FFFE and \$FFFF do not contain \$FF (programmed state):
  - The external clock is 4.9152 MHz with PTC1 low or 9.8304 MHz with PTC1 high
  - $\overline{\text{IRQ}} = V_{\text{TST}}$  (PLL off)
2. If \$FFFE and \$FFFF both contain \$FF (erased state):
  - The external clock is 9.8304 MHz
  - $\overline{\text{IRQ}} = V_{\text{DD}}$  (this can be implemented through the internal  $\overline{\text{IRQ}}$  pullup; PLL off)
3. If \$FFFE and \$FFFF both contain \$FF (erased state):
  - The external clock is 32.768 kHz (crystal)
  - $\overline{\text{IRQ}} = V_{\text{SS}}$  (this setting initiates the PLL to boost the external 32.768 kHz to an internal bus frequency of 2.4576 MHz)

If  $V_{\text{TST}}$  is applied to  $\overline{\text{IRQ}}$  and PTC1 is low upon monitor mode entry (above condition set 1), the bus frequency is a divide-by-two of the input clock. If PTC1 is high with  $V_{\text{TST}}$  applied to  $\overline{\text{IRQ}}$  upon monitor mode entry, the bus frequency will be a divide-by-four of the input clock. Holding the PTC1 pin low when entering monitor mode causes a bypass of a divide-by-two stage at the oscillator only if  $V_{\text{TST}}$  is applied to  $\overline{\text{IRQ}}$ . In this event, the CGMOUT frequency is equal to the CGMXCLK frequency, and the OSC1 input directly generates internal bus clocks. In this case, the OSC1 signal must have a 50% duty cycle at maximum bus frequency.

If entering monitor mode without high voltage on  $\overline{\text{IRQ}}$  (above condition set 2 or 3, where applied voltage is either  $V_{\text{DD}}$  or  $V_{\text{SS}}$ ), then all port A pin requirements and conditions, including the PTC1 frequency divisor selection, are not in effect. This is to reduce circuit requirements when performing in-circuit programming.

Table 10-1. Monitor Mode Signal Requirements and Options

IRQ	RST	Address \$FFF0/\$FFF4	PTA2	PTA1	PTA0 <sup>(1)</sup>	PTC1	External Clock <sup>(2)</sup>	Bus Frequency	PLL	COP	Baud Rate	Comment
X	GND	X	X	X	X	X	X	0	X	Disabled	0	No operation until reset goes high
V <sub>TST</sub> <sup>(3)</sup>	V <sub>DD</sub> or V <sub>TST</sub>	X	0	1	1	0	4.9152 MHz	2.4576 MHz	OFF	Disabled	9600	PTA1 and PTA2 voltages only required if IRQ = V <sub>TST</sub> . PTC1 determines frequency divider
V <sub>TST</sub> <sup>(3)</sup>	V <sub>DD</sub> or V <sub>TST</sub>	X	0	1	1	1	9.8304 MHz	2.4576 MHz	OFF	Disabled	9600	PTA1 and PTA2 voltages only required if IRQ = V <sub>TST</sub> . PTC1 determines frequency divider
V <sub>DD</sub>	V <sub>DD</sub>	Blank "\$FFFF"	X	X	1	X	9.8304 MHz	2.4576 MHz	OFF	Disabled	9600	External frequency always divided by 4
GND	V <sub>DD</sub>	Blank "\$FFFF"	X	X	1	X	32.768 KHz	2.4576 MHz	ON	Disabled	9600	PLL enabled (BCS set) in monitor code
V <sub>DD</sub> or GND	V <sub>TST</sub>	Blank "\$FFFF"	X	X	X	X	X	—	OFF	Enabled	—	Enters user mode — will encounter an illegal address reset
V <sub>DD</sub> or GND	V <sub>DD</sub> or V <sub>TST</sub>	Not Blank	X	X	X	X	X	—	OFF	Enabled	—	Enters user mode

**Notes:**

1. PTA0 = 1 if serial communication; PTA0 = 0 if parallel communication
2. External clock is derived by a 32.768 KHz crystal or a 4.9152/9.8304 MHz off-chip oscillator
3. Monitor mode entry by IRQ = V<sub>TST</sub>, a 4.9152/9.8304 MHz off-chip oscillator must be used. The MCU internal crystal oscillator circuit is bypassed.



**NOTE:** *If the reset vector is blank and monitor mode is entered, the chip will see an additional reset cycle after the initial POR reset. Once the part has been programmed, the traditional method of applying a voltage,  $V_{TST}$ , to  $\overline{IRQ}$  must be used to enter monitor mode.*

The COP module is disabled in monitor mode based on these conditions:

- If monitor mode was entered as a result of the reset vector being blank (above condition set 2 or 3), the COP is always disabled regardless of the state of  $\overline{IRQ}$  or  $\overline{RST}$ .
- If monitor mode was entered with  $V_{TST}$  on  $\overline{IRQ}$  (condition set 1), then the COP is disabled as long as  $V_{TST}$  is applied to either  $\overline{IRQ}$  or  $\overline{RST}$ .

The second condition states that as long as  $V_{TST}$  is maintained on the  $\overline{IRQ}$  pin after entering monitor mode, or if  $V_{TST}$  is applied to  $\overline{RST}$  after the initial reset to get into monitor mode (when  $V_{TST}$  was applied to  $\overline{IRQ}$ ), then the COP will be disabled. In the latter situation, after  $V_{TST}$  is applied to the  $\overline{RST}$  pin,  $V_{TST}$  can be removed from the  $\overline{IRQ}$  pin in the interest of freeing the  $\overline{IRQ}$  for normal functionality in monitor mode.

**Figure 10-2** shows a simplified diagram of the monitor mode entry when the reset vector is blank and just  $1 \times V_{DD}$  voltage is applied to the  $\overline{IRQ}$  pin. An external oscillator of 9.8304 MHz is required for a baud rate of 9600, as the internal bus frequency is automatically set to the external frequency divided by four.

Enter monitor mode with pin configuration shown in **Figure 10-1** by pulling  $\overline{RST}$  low and then high. The rising edge of  $\overline{RST}$  latches monitor mode. Once monitor mode is latched, the values on the specified pins can change.

Once out of reset, the MCU waits for the host to send eight security bytes. (See **10.5 Security**.) After the security bytes, the MCU sends a break signal (10 consecutive logic 0s) to the host, indicating that it is ready to receive a command.

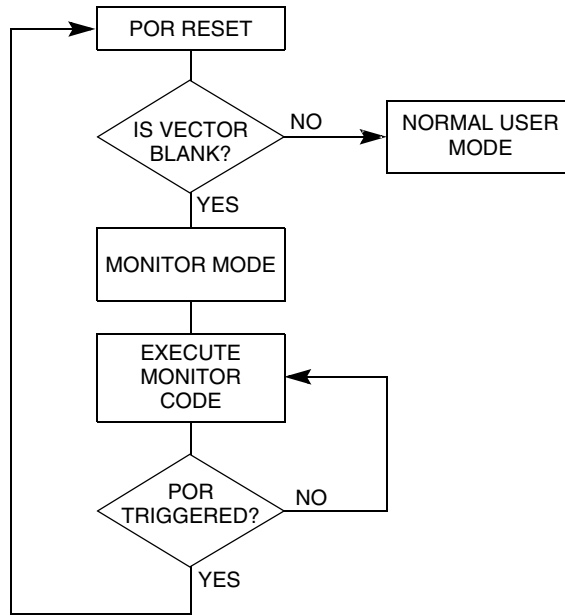


Figure 10-2. Low-Voltage Monitor Mode Entry Flowchart

In monitor mode, the MCU uses different vectors for reset, SWI (software interrupt), and break interrupt than those for user mode. The alternate vectors are in the \$FE page instead of the \$FF page and allow code execution from the internal monitor firmware instead of user code.

**NOTE:** *Exiting monitor mode after it has been initiated by having a blank reset vector requires a power-on reset (POR). Pulling  $\overline{RST}$  low will not exit monitor mode in this situation.*

Table 10-2 summarizes the differences between user mode and monitor mode vectors.

Table 10-2. Mode Differences (Vectors)

Modes	Functions					
	Reset Vector High	Reset Vector Low	Break Vector High	Break Vector Low	SWI Vector High	SWI Vector Low
User	\$FFFE	\$FFFF	\$FFFC	\$FFFD	\$FFFC	\$FFFD
Monitor	\$FEFE	\$FEFF	\$FEFC	\$FEFD	\$FEFC	\$FEFD

### 10.4.2 Data Format

Communication with the monitor ROM is in standard non-return-to-zero (NRZ) mark/space data format. Transmit and receive baud rates must be identical.

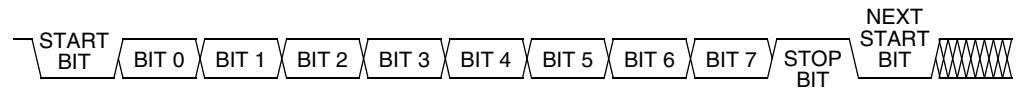


Figure 10-3. Monitor Data Format

### 10.4.3 Break Signal

A start bit (logic 0) followed by nine logic 0 bits is a break signal. When the monitor receives a break signal, it drives the PTA0 pin high for the duration of two bits and then echoes back the break signal.

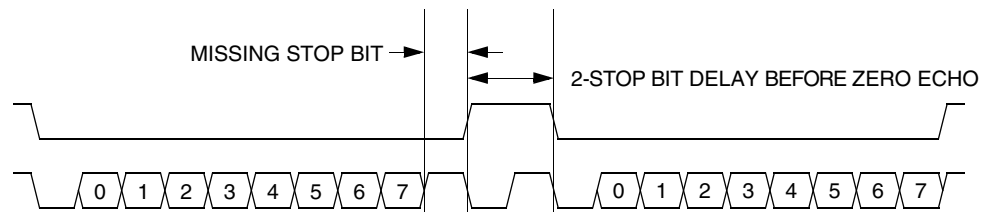


Figure 10-4. Break Transaction

### 10.4.4 Baud Rate

The communication baud rate is controlled by the crystal frequency and the state of the PTC1 pin (when  $\overline{IRQ}$  is set to  $V_{TST}$ ) upon entry into monitor mode. When PTC1 is high, the divide by ratio is 1024. If the PTC1 pin is at logic 0 upon entry into monitor mode, the divide by ratio is 512.

If monitor mode was entered with  $V_{DD}$  on  $\overline{IRQ}$ , then the divide by ratio is set at 1024, regardless of PTC1. If monitor mode was entered with  $V_{SS}$  on  $\overline{IRQ}$ , then the internal PLL steps up the external frequency, presumed to be 32.768 kHz, to 2.4576 MHz. These latter two conditions for monitor mode entry require that the reset vector is blank.

**Table 10-3** lists external frequencies required to achieve a standard baud rate of 9600 BPS. Other standard baud rates can be accomplished using proportionally higher or lower frequency generators. If using a crystal as the clock source, be aware of the upper frequency limit that the internal clock module can handle.

**Table 10-3. Monitor Baud Rate Selection**

External Frequency	$\overline{\text{IRQ}}$	PTC1	Internal Frequency	Baud Rate (BPS)
4.9152 MHz	$V_{\text{TST}}$	0	2.4576 MHz	9600
9.8304 MHz	$V_{\text{TST}}$	1	2.4576 MHz	9600
9.8304 MHz	$V_{\text{DD}}$	X	2.4576 MHz	9600
32.768 kHz	$V_{\text{SS}}$	X	2.4576 MHz	9600

#### 10.4.5 Commands

The monitor ROM firmware uses these commands:

- READ (read memory)
- WRITE (write memory)
- IREAD (indexed read)
- IWRITE (indexed write)
- READSP (read stack pointer)
- RUN (run user program)

The monitor ROM firmware echoes each received byte back to the PTA0 pin for error checking. An 11-bit delay at the end of each command allows the host to send a break character to cancel the command. A delay of two bit times occurs before each echo and before READ, IREAD, or READSP data is returned. The data returned by a read command appears after the echo of the last byte of the command.

**NOTE:** *Wait one bit time after each echo before sending the next byte.*

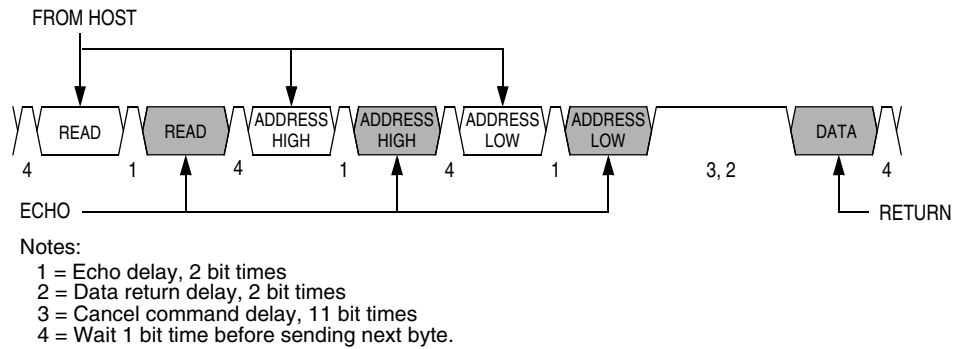


Figure 10-5. Read Transaction

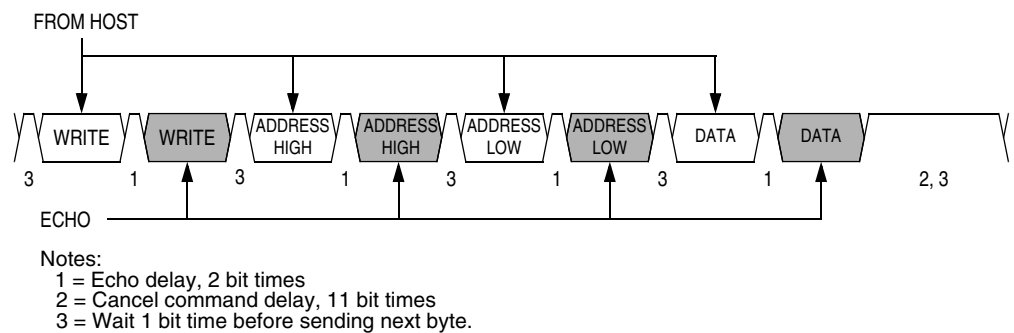


Figure 10-6. Write Transaction

A brief description of each monitor mode command is given in [Table 10-4](#) through [Table 10-9](#).

Table 10-4. READ (Read Memory) Command

<b>Description</b>	Read byte from memory
<b>Operand</b>	2-byte address in high-byte:low-byte order
<b>Data Returned</b>	Returns contents of specified address
<b>Opcode</b>	\$4A
<b>Command Sequence</b>	
<p>SENT TO MONITOR</p> <p>READ ADDRESS HIGH ADDRESS LOW DATA</p> <p>ECHO</p> <p>RETURN</p>	

**Table 10-5. WRITE (Write Memory) Command**

<b>Description</b>	Write byte to memory
<b>Operand</b>	2-byte address in high-byte:low-byte order; low byte followed by data byte
<b>Data Returned</b>	None
<b>Opcode</b>	\$49
<b>Command Sequence</b>	

**Table 10-6. IREAD (Indexed Read) Command**

<b>Description</b>	Read next 2 bytes in memory from last address accessed
<b>Operand</b>	2-byte address in high byte:low byte order
<b>Data Returned</b>	Returns contents of next two addresses
<b>Opcode</b>	\$1A
<b>Command Sequence</b>	

**Table 10-7. IWRITE (Indexed Write) Command**

<b>Description</b>	Write to last address accessed + 1
<b>Operand</b>	Single data byte
<b>Data Returned</b>	None
<b>Opcode</b>	\$19
<b>Command Sequence</b>	

A sequence of IREAD or IWRITE commands can access a block of memory sequentially over the full 64-Kbyte memory map.

**Table 10-8. READSP (Read Stack Pointer) Command**

<b>Description</b>	Reads stack pointer
<b>Operand</b>	None
<b>Data Returned</b>	Returns incremented stack pointer value (SP + 1) in high-byte:low-byte order
<b>Opcode</b>	\$0C
<b>Command Sequence</b>	

Table 10-9. RUN (Run User Program) Command

<b>Description</b>	Executes PULH and RTI instructions
<b>Operand</b>	None
<b>Data Returned</b>	None
<b>Opcode</b>	\$28
<p><b>Command Sequence</b></p>	

The MCU executes the SWI and PSHH instructions when it enters monitor mode. The RUN command tells the MCU to execute the PULH and RTI instructions. Before sending the RUN command, the host can modify the stacked CPU registers to prepare to run the host program. The READSP command returns the incremented stack pointer value, SP + 1. The high and low bytes of the program counter are at addresses SP + 5 and SP + 6.

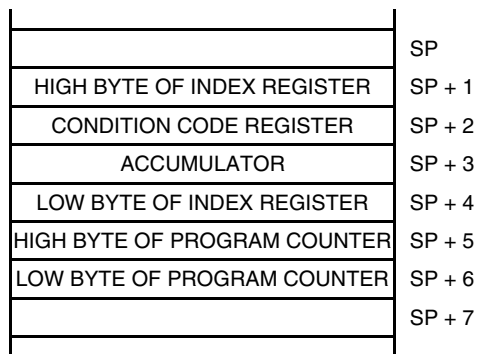


Figure 10-7. Stack Pointer at Monitor Mode Entry



## 10.5 Security

A security feature discourages unauthorized reading of FLASH locations while in monitor mode. The host can bypass the security feature at monitor mode entry by sending eight security bytes that match the bytes at locations \$FFF6–\$FFFD. Locations \$FFF6–\$FFFD contain user-defined data.

**NOTE:** Do not leave locations \$FFF6–\$FFFD blank. For security reasons, program locations \$FFF6–\$FFFD even if they are not used for vectors.

During monitor mode entry, the MCU waits after the power-on reset for the host to send the eight security bytes on pin PTA0. If the received bytes match those at locations \$FFF6–\$FFFD, the host bypasses the security feature and can read all FLASH locations and execute code from FLASH. Security remains bypassed until a power-on reset occurs. If the reset was not a power-on reset, security remains bypassed and security code entry is not required. (See [Figure 10-8.](#))

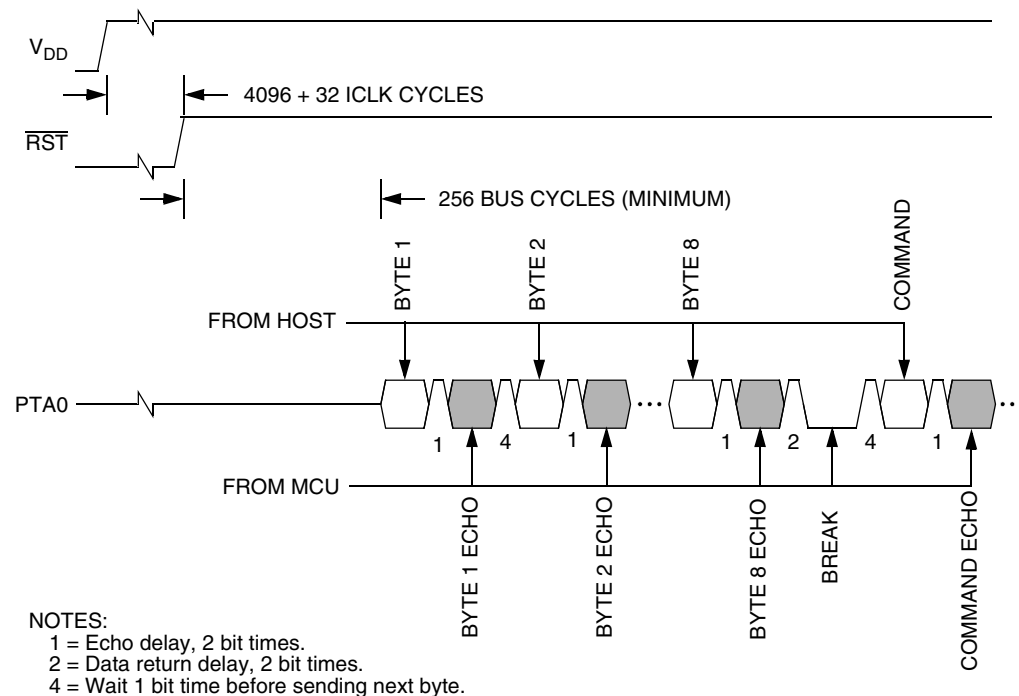


Figure 10-8. Monitor Mode Entry Timing

Upon power-on reset, if the received bytes of the security code do not match the data at locations \$FFF6–\$FFFD, the host fails to bypass the security feature. The MCU remains in monitor mode, but reading a FLASH location returns an invalid value and trying to execute code from FLASH causes an illegal address reset. After receiving the eight security bytes from the host, the MCU transmits a break character, signifying that it is ready to receive a command.

**NOTE:** *The MCU does not transmit a break character until after the host sends the eight security bits.*

To determine whether the security code entered is correct, check to see if bit 6 of RAM address \$40 is set. If it is, then the correct security code has been entered and FLASH can be accessed.

If the security sequence fails, the device should be reset by a power-on reset and brought up in monitor mode to attempt another entry. After failing the security sequence, the FLASH module can also be mass erased by executing an erase routine that was downloaded into internal RAM. The mass erase operation clears the security code locations so that all eight security bytes become \$FF (blank).

## 10.6 ROM-Resident Routines

Eight routines stored in the monitor ROM area (thus ROM-resident) are provided for FLASH memory manipulation. Six of the eight routines are intended to simplify FLASH program, erase, and load operations. The other two routines are intended to simplify the use of the FLASH memory as EEPROM. **Table 10-10** shows a summary of the ROM-resident routines.

**Table 10-10. Summary of ROM-Resident Routines**

Routine Name	Routine Description	Call Address	Stack Used (bytes)
<b>PRGRNGE</b>	Program a range of locations	\$FC06	14
<b>ERARNGE</b>	Erase a page or the entire array	\$FCBE	9
<b>LDRNGE</b>	Loads data from a range of locations	\$FF30	9
<b>MON_PRGRNGE</b>	Program a range of locations in monitor mode	\$FF28	16
<b>MON_ERARNGE</b>	Erase a page or the entire array in monitor mode	\$FF2C	11
<b>MON_LDRNGE</b>	Loads data from a range of locations in monitor mode	\$FF24	11
<b>EE_WRITE</b>	Emulated EEPROM write. Data size ranges from 2 to 15 bytes at a time.	\$FC00	17
<b>EE_READ</b>	Emulated EEPROM read. Data size ranges from 2 to 15 bytes at a time.	\$FC03	15

The routines are designed to be called as stand-alone subroutines in the user program or monitor mode. The parameters that are passed to a routine are in the form of a contiguous data block, stored in RAM. The index register (H:X) is loaded with the address of the first byte of the data block (acting as a pointer), and the subroutine is called (JSR). Using the start address as a pointer, multiple data blocks can be used, any area of RAM be used. A data block has the control and data bytes in a defined order, as shown in **Figure 10-9**.

During the software execution, it does not consume any dedicated RAM location, the run-time heap will extend the system stack, all other RAM location will not be affected.

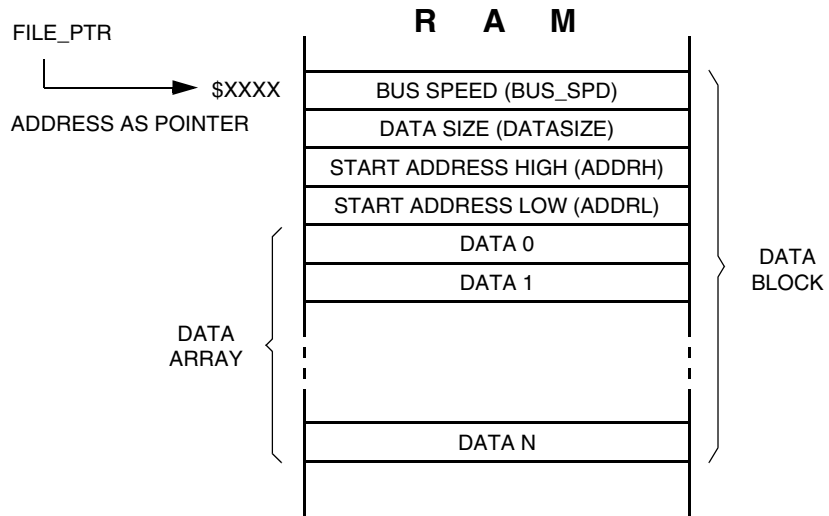


Figure 10-9. Data Block Format for ROM-Resident Routines

The control and data bytes are described below.

- **Bus speed** — This one byte indicates the operating bus speed of the MCU. The value of this byte should be equal to 4 times the bus speed. E.g., for a 4MHz bus, the value is 16 (\$10). This control byte is useful where the MCU clock source is switched between the PLL clock and the crystal clock.
- **Data size** — This one byte indicates the number of bytes in the data array that are to be manipulated. The maximum data array size is 255. Routines EE\_WRITE and EE\_READ are restricted to manipulate a data array between 2 to 15 bytes. Whereas routines ERARNGE and MON\_ERARNGE do not manipulate a data array, thus, this data size byte has no meaning.
- **Start address** — These two bytes, high byte followed by low byte, indicate the start address of the FLASH memory to be manipulated.
- **Data array** — This data array contains data that are to be manipulated. Data in this array are programmed to FLASH memory by the programming routines: PRGRNGE, MON\_PRGRNGE, EE\_WRITE. For the read routines: LDRNGE, MON\_LDRNGE, and EE\_READ, data is read from FLASH and stored in this array.

**10.6.1 PRGRNGE**

PRGRNGE is used to program a range of FLASH locations with data loaded into the data array.

**Table 10-11. PRGRNGE Routine**

<b>Routine Name</b>	PRGRNGE
<b>Routine Description</b>	Program a range of locations
<b>Calling Address</b>	\$FC06
<b>Stack Used</b>	14 bytes
<b>Data Block Format</b>	Bus speed (BUS_SPD) Data size (DATASIZE) Start address high (ADDRH) Start address (ADDRL) Data 1 (DATA1) : Data N (DATAN)

The start location of the FLASH to be programmed is specified by the address ADDRH:ADDRL and the number of bytes from this location is specified by DATASIZE. The maximum number of bytes that can be programmed in one routine call is 255 bytes (max. DATASIZE is 255).

ADDRH:ADDRL do not need to be at a page boundary, the routine handles any boundary misalignment during programming. A check to see that all bytes in the specified range are erased is not performed by this routine prior programming. Nor does this routine do a verification after programming, so there is no return confirmation that programming was successful. User must assure that the range specified is first erased.

The coding example below is to program 64 bytes of data starting at FLASH location \$EF00, with a bus speed of 4.9152 MHz. The coding assumes the data block is already loaded in RAM, with the address pointer, FILE\_PTR, pointing to the first byte of the data block.

Monitor ROM (MON)

```

                                ORG     RAM
                                :
FILE_PTR:
BUS_SPD      DS.B      1      ; Indicates 4x bus frequency
DATASIZE     DS.B      1      ; Data size to be programmed
START_ADDR   DS.W      1      ; FLASH start address
DATAARRAY    DS.B      64     ; Reserved data array

PRGRNGE      EQU       $FC06
FLASH_START  EQU       $EF00

                                ORG     FLASH
INITIALISATION:
MOV          #20,      BUS_SPD
MOV          #64,      DATASIZE
LDHX        #FLASH_START
STHX        START_ADDR
RTS

MAIN:
BSR         INITIALISATION
:
:
LDHX        #FILE_PTR
JSR         PRGRNGE
    
```

Freescale Semiconductor, Inc.

10.6.2 ERARNGE

ERARNGE is used to erase a range of locations in FLASH.

Table 10-12. ERARNGE Routine

<b>Routine Name</b>	ERARNGE
<b>Routine Description</b>	Erase a page or the entire array
<b>Calling Address</b>	\$FCBE
<b>Stack Used</b>	9 bytes
<b>Data Block Format</b>	Bus speed (BUS_SPD) Data size (DATASIZE) Starting address (ADDRH) Starting address (ADDRL)

There are two sizes of erase ranges: a page or the entire array. The ERARNGE will erase the page (128 consecutive bytes) in FLASH specified by the address ADDRH:ADDRL. This address can be any address within the page. Calling ERARNGE with ADDRH:ADDRL equal to \$FFFF will erase the entire FLASH array (mass erase). Therefore, care must be taken when calling this routine to prevent an accidental mass erase.

The ERARNGE routine do not use a data array. The DATASIZE byte is a dummy byte that is also not used.

The coding example below is to perform a page erase, from \$EF00-\$EF7F. The Initialization subroutine is the same as the coding example for PRGRNGE (see [10.6.1 PRGRNGE](#)).

```
ERARNGE      EQU      $FCBE
MAIN:
      BSR      INITIALISATION
      :
      :
      LDHX     #FILE_PTR
      JSR      ERARNGE
      :
```

10.6.3 LDRNGE

LDRNGE is used to load the data array in RAM with data from a range of FLASH locations.

Table 10-13. LDRNGE Routine

<b>Routine Name</b>	LDRNGE
<b>Routine Description</b>	Loads data from a range of locations
<b>Calling Address</b>	\$FF30
<b>Stack Used</b>	9 bytes
<b>Data Block Format</b>	Bus speed (BUS_SPD) Data size (DATASIZE) Starting address (ADDRH) Starting address (ADDRL) Data 1 : Data N

The start location of FLASH from where data is retrieved is specified by the address ADDRH:ADDRL and the number of bytes from this location is specified by DATASIZE. The maximum number of bytes that can be retrieved in one routine call is 255 bytes. The data retrieved from FLASH is loaded into the data array in RAM. Previous data in the data array will be overwritten. User can use this routine to retrieve data from FLASH that was previously programmed.

The coding example below is to retrieve 64 bytes of data starting from \$EF00 in FLASH. The Initialization subroutine is the same as the coding example for PRGRNGE (see [10.6.1 PRGRNGE](#)).

```
LDRNGE      EQU      $FF30
MAIN:
      BSR      INITIALIZATION
      :
      :
      LDHX     #FILE_PTR
      JSR      LDRNGE
      :
```



**10.6.4 MON\_PRGRNGE**

In monitor mode, MON\_PRGRNGE is used to program a range of FLASH locations with data loaded into the data array.

**Table 10-14. MON\_PRGRNGE Routine**

<b>Routine Name</b>	MON_PRGRNGE
<b>Routine Description</b>	Program a range of locations, in monitor mode
<b>Calling Address</b>	\$FC28
<b>Stack Used</b>	16 bytes
<b>Data Block Format</b>	Bus speed Data size Starting address (high byte) Starting address (low byte) Data 1 : Data N

The MON\_PRGRNGE routine is designed to be used in monitor mode. It performs the same function as the PRGRNGE routine (see [10.6.1 PRGRNGE](#)), except that MON\_PRGRNGE returns to the main program via an SWI instruction. After a MON\_PRGRNGE call, the SWI instruction will return the control back to the monitor code.

## 10.6.5 MON\_ERARNGE

In monitor mode, ERARNGE is used to erase a range of locations in FLASH.

Table 10-15. MON\_ERARNGE Routine

<b>Routine Name</b>	MON_ERARNGE
<b>Routine Description</b>	Erase a page or the entire array, in monitor mode
<b>Calling Address</b>	\$FF2C
<b>Stack Used</b>	11 bytes
<b>Data Block Format</b>	Bus speed Data size Starting address (high byte) Starting address (low byte)

The MON\_ERARNGE routine is designed to be used in monitor mode. It performs the same function as the ERARNGE routine (see [10.6.2 ERARNGE](#)), except that MON\_ERARNGE returns to the main program via an SWI instruction. After a MON\_ERARNGE call, the SWI instruction will return the control back to the monitor code.

**10.6.6 MON\_LDRNGE**

In monitor mode, LDRNGE is used to load the data array in RAM with data from a range of FLASH locations.

**Table 10-16. ICP\_LDRNGE Routine**

<b>Routine Name</b>	MON_LDRNGE
<b>Routine Description</b>	Loads data from a range of locations, in monitor mode
<b>Calling Address</b>	\$FF24
<b>Stack Used</b>	11 bytes
<b>Data Block Format</b>	Bus speed Data size Starting address (high byte) Starting address (low byte) Data 1 : Data N

The MON\_LDRNGE routine is designed to be used in monitor mode. It performs the same function as the LDRNGE routine (see [10.6.3 LDRNGE](#)), except that MON\_LDRNGE returns to the main program via an SWI instruction. After a MON\_LDRNGE call, the SWI instruction will return the control back to the monitor code.

10.6.7 EE\_WRITE

EE\_WRITE is used to write a set of data from the data array to FLASH.

Table 10-17. EE\_WRITE Routine

<b>Routine Name</b>	EE_WRITE
<b>Routine Description</b>	Emulated EEPROM write. Data size ranges from 2 to 15 bytes at a time.
<b>Calling Address</b>	\$FC00
<b>Stack Used</b>	17 bytes
<b>Data Block Format</b>	Bus speed (BUS_SPD) Data size (DATASIZE) <sup>(1)</sup> Starting address (ADDRH) <sup>(2)</sup> Starting address (ADDRL) <sup>(1)</sup> Data 1 : Data N

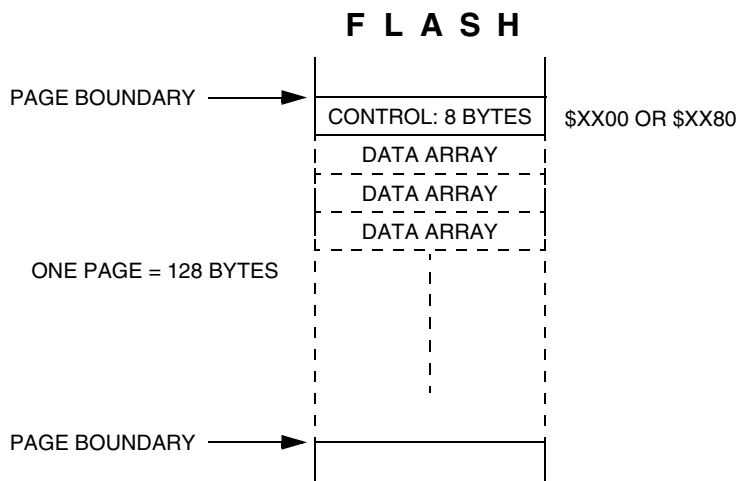
**Notes:**

1. The minimum data size is 2 bytes. The maximum data size is 15 bytes.
2. The start address must be a page boundary start address, e.g. \$xx00 or \$xx80.

The start location of the FLASH to be programmed is specified by the address ADDRH:ADDRL and the number of bytes in the data array is specified by DATASIZE. The minimum number of bytes that can be programmed in one routine call is 2 bytes, the maximum is 15 bytes. ADDRH:ADDRL must always be the start of boundary address (the page start address: \$XX00 or \$0080) and DATASIZE must be the same size when accessing the same page.

In some applications, the user may want to repeatedly store and read a set of data from an area of non-volatile memory. This is easily possible when using an EEPROM array. As the write and erase operations can be executed on a byte basis. For FLASH memory, the minimum erase size is the page — 128 bytes per page for MC68HC908LJ24. If the data array size is less than the page size, writing and erasing to the same page cannot fully utilize the page. Unused locations in the page will be wasted. The EE\_WRITE routine is designed to emulate the properties similar to the EEPROM. Allowing a more efficient use of the FLASH page for data storage.

When the user dedicates a page of FLASH for data storage, and the size of the data array defined, each call of the EE\_WRTIE routine will automatically transfer the data in the data array (in RAM) to the next blank block of locations in the FLASH page. Once a page is filled up, the EE\_WRITE routine automatically erases the page, and starts reuse the page again. In the 128-byte page, an 8-byte control block is used by the routine to monitor the utilization of the page. In effect, only 120 bytes are used for data storage. (see **Figure 10-10**). The page control operations are transparent to the user.



**Figure 10-10. EE\_WRITE FLASH Memory Usage**

When using this routine to store a 2-byte data array, the FLASH page can be programmed 60 times before the an erase is required. In effect, the write/erase endurance is increased by 60 times. When a 15-byte data array is used, the write/erase endurance is increased by 8 times. Due to the FLASH page size limitation, the data array is limited from 2 bytes to 15 bytes.

The coding example below uses the \$EF00–\$EE7F page for data storage. The data array size is 15 bytes, and the bus speed is 4.9152 MHz. The coding assumes the data block is already loaded in RAM, with the address pointer, FILE\_PTR, pointing to the first byte of the data block.

Monitor ROM (MON)

```

                                ORG     RAM
                                :
FILE_PTR:
BUS_SPD      DS.B      1      ; Indicates 4x bus frequency
DATASIZE     DS.B      1      ; Data size to be programmed
START_ADDR   DS.W      1      ; FLASH starting address
DATAARRAY    DS.B      15     ; Reserved data array

EE_WRITE     EQU       $FC00
FLASH_START  EQU       $EF00

                                ORG     FLASH
INITIALISATION:
MOV          #20,        BUS_SPD
MOV          #15,        DATASIZE
LDHX        #FLASH_START
STHX        START_ADDR
RTS

MAIN:
BSR         INITIALISATION
:
:
LHDX       #FILE_PTR
JSR        EE_WRITE
    
```

**NOTE:** *The EE\_WRITE routine is unable to check for incorrect data blocks, such as the FLASH page boundary address and data size. It is the responsibility of the user to ensure the starting address indicated in the data block is at the FLASH page boundary and the data size is 2 to 15. If the FLASH page is already programmed with a data array with a different size, the EE\_WRITE call will be ignored.*

10.6.8 EE\_READ

EE\_READ is used to load the data array in RAM with a set of data from FLASH.

Table 10-18. EE\_READ Routine

<b>Routine Name</b>	EE_READ
<b>Routine Description</b>	Emulated EEPROM read. Data size ranges from 2 to 15 bytes at a time.
<b>Calling Address</b>	\$FC03
<b>Stack Used</b>	15 bytes
<b>Data Block Format</b>	Bus speed (BUS_SPD) Data size (DATASIZE) Starting address (ADDRH) <sup>(1)</sup> Starting address (ADDRL) <sup>(1)</sup> Data 1 : Data N

**Notes:**

1. The start address must be a page boundary start address, e.g. \$xx00 or \$xx80.

The EE\_READ routine reads data stored by the EE\_WRITE routine. An EE\_READ call will retrieve the last data written to a FLASH page and loaded into the data array in RAM. Same as EE\_WRITE, the data size indicated by DATASIZE is 2 to 15, and the start address ADDRH:ADDRL must be the FLASH page boundary address.

The coding example below uses the data stored by the EE\_WRITE coding example (see [10.6.7 EE\\_WRITE](#)). It loads the 15-byte data set stored in the \$EF00-\$EE7F page to the data array in RAM. The initialization subroutine is the same as the coding example for EE\_WRITE (see [10.6.7 EE\\_WRITE](#)).

```
EE_READ      EQU      $FC03

MAIN:
    BSR      INITIALIZATION
    :
    :
    LDHX     #FILE_PTR
    JSR      EE_READ
    :
```

**NOTE:** *The EE\_READ routine is unable to check for incorrect data blocks, such as the FLASH page boundary address and data size. It is the responsibility of the user to ensure the starting address indicated in the data block is at the FLASH page boundary and the data size is 2 to 15. If the FLASH page is programmed with a data array with a different size, the EE\_READ call will be ignored.*



## Section 11. Timer Interface Module (TIM)

### 11.1 Contents

11.2	Introduction	194
11.3	Features	194
11.4	Pin Name Conventions	195
11.5	Functional Description	195
11.5.1	TIM Counter Prescaler	199
11.5.2	Input Capture	199
11.5.3	Output Compare	200
11.5.3.1	Unbuffered Output Compare	200
11.5.3.2	Buffered Output Compare	201
11.5.4	Pulse Width Modulation (PWM)	201
11.5.4.1	Unbuffered PWM Signal Generation	202
11.5.4.2	Buffered PWM Signal Generation	203
11.5.4.3	PWM Initialization	204
11.6	Interrupts	205
11.7	Low-Power Modes	205
11.7.1	Wait Mode	206
11.7.2	Stop Mode	206
11.8	TIM During Break Interrupts	206
11.9	I/O Signals	207
11.9.1	TIM Clock Pins	207
11.9.2	TIM Channel I/O Pins	207
11.10	I/O Registers	208
11.10.1	TIM Status and Control Register	208
11.10.2	TIM Counter Registers	210
11.10.3	TIM Counter Modulo Registers	211
11.10.4	TIM Channel Status and Control Registers	212
11.10.5	TIM Channel Registers	215

## 11.2 Introduction

This section describes the timer interface (TIM) module. The TIM is a two-channel timer that provides a timing reference with input capture, output compare, and pulse-width-modulation functions. **Figure 11-1** is a block diagram of the TIM.

This particular MCU has two timer interface modules which are denoted as TIM1 and TIM2.

## 11.3 Features

Features of the TIM include:

- Two input capture/output compare channels:
  - Rising-edge, falling-edge, or any-edge input capture trigger
  - Set, clear, or toggle output compare action
- Buffered and unbuffered pulse-width-modulation (PWM) signal generation
- Programmable TIM clock input
  - 7-frequency internal bus clock prescaler selection
  - External TIM clock input (bus frequency  $\div 2$  maximum)
- Free-running or modulo up-count operation
- Toggle any channel pin on overflow
- TIM counter stop and reset bits

## 11.4 Pin Name Conventions

The text that follows describes both timers, TIM1 and TIM2. The TIM input/output (I/O) pin names are T[1,2]CH0 (timer channel 0), T[1,2]CH1 (timer channel 1), and T[1,2]CLK (external timer clock), where “1” is used to indicate TIM1 and “2” is used to indicate TIM2. The full names of the TIM I/O pins are listed in **Table 11-1**. The generic pin names appear in the text that follows.

**Table 11-1. Pin Name Conventions**

TIM Generic Pin Names:		T[1,2]CH0	T[1,2]CH1	T[1,2]CLK
Full TIM Pin Names:	TIM1	PTB2/T1CH0	PTB3/T1CH1	PTD4/KBI4/T1CLK
	TIM2	PTB4/T2CH0	PTB5/T2CH1	PTD5/KBI5/T2CLK

**NOTE:** *References to either timer 1 or timer 2 may be made in the following text by omitting the timer number. For example, TCH0 may refer generically to T1CH0 and T2CH0, and TCH1 may refer to T1CH1 and T2CH1.*

*The T1CLK and T2CLK pins are also shared with KBI4 and KBI5 respectively. To avoid erratic behavior, these two pins should never be configured for use as TCLK and KBI inputs simultaneously.*

## 11.5 Functional Description

**Figure 11-1** shows the structure of the TIM. The central component of the TIM is the 16-bit TIM counter that can operate as a free-running counter or a modulo up-counter. The TIM counter provides the timing reference for the input capture and output compare functions. The TIM counter modulo registers, TMODH:TMODL, control the modulo value of the TIM counter. Software can read the TIM counter value at any time without affecting the counting sequence.

The two TIM channels (per timer) are programmable independently as input capture or output compare channels.

Timer Interface Module (TIM)

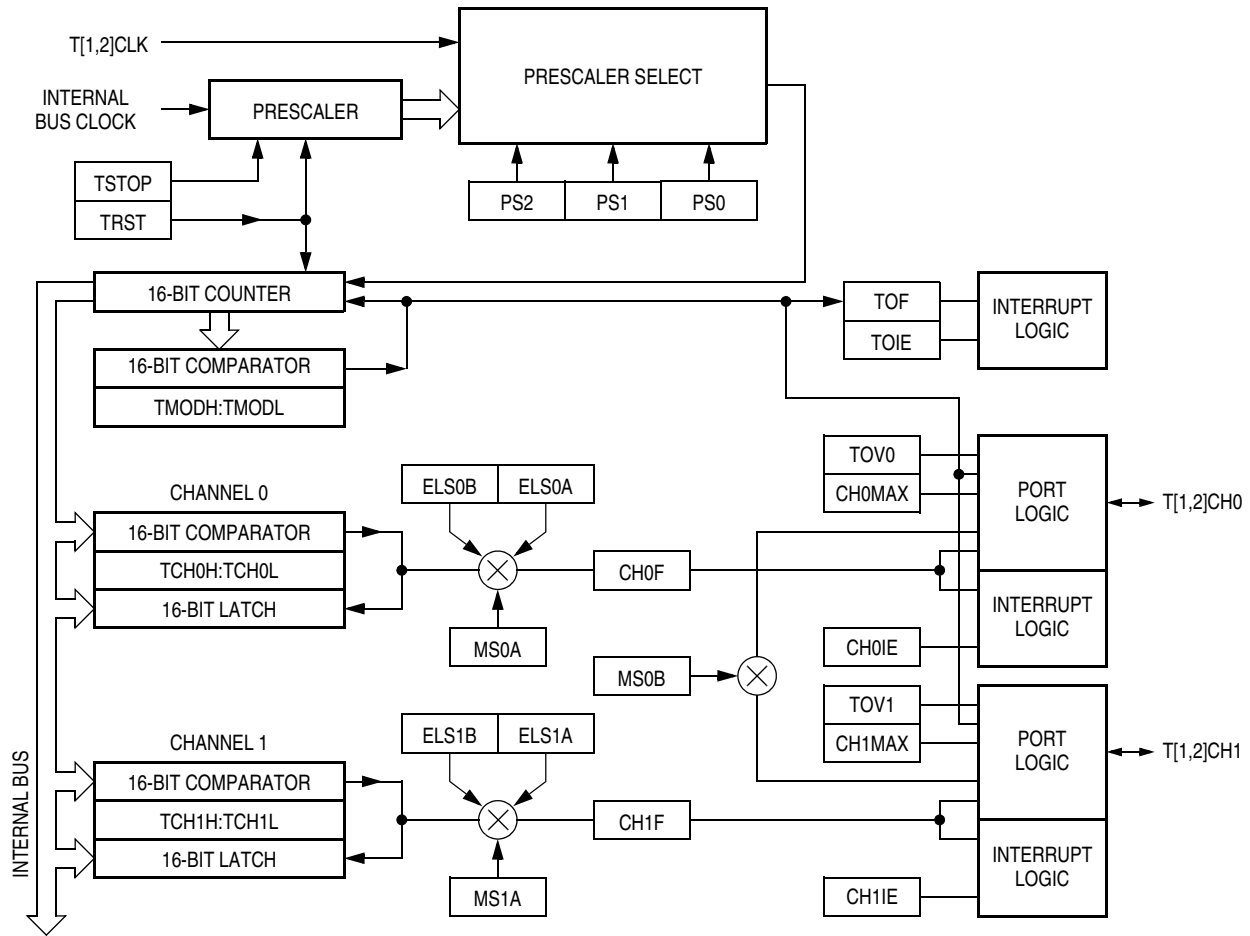


Figure 11-1. TIM Block Diagram

Figure 11-2 summarizes the timer registers.

**NOTE:** References to either timer 1 or timer 2 may be made in the following text by omitting the timer number. For example, TSC may generically refer to both T1SC and T2SC.

Addr.	Register Name	Bit 7	6	5	4	3	2	1	Bit 0	
\$0020	Timer 1 Status and Control Register (T1SC)	Read:	TOF	TOIE	TSTOP	0	0	PS2	PS1	PS0
		Write:	0			TRST				
		Reset:	0	0	1	0	0	0	0	0
\$0021	Timer 1 Counter Register High (T1CNTH)	Read:	Bit 15	14	13	12	11	10	9	Bit 8
		Write:								
		Reset:	0	0	0	0	0	0	0	0
\$0022	Timer 1 Counter Register Low (T1CNTL)	Read:	Bit 7	6	5	4	3	2	1	Bit 0
		Write:								
		Reset:	0	0	0	0	0	0	0	0
\$0023	Timer 1 Counter Modulo Register High (T1MODH)	Read:	Bit 15	14	13	12	11	10	9	Bit 8
		Write:								
		Reset:	1	1	1	1	1	1	1	1
\$0024	Timer 1 Counter Modulo Register Low (T1MODL)	Read:	Bit 7	6	5	4	3	2	1	Bit 0
		Write:								
		Reset:	1	1	1	1	1	1	1	1
\$0025	Timer 1 Channel 0 Status and Control Register (T1SC0)	Read:	CH0F	CH0IE	MS0B	MS0A	ELS0B	ELS0A	TOV0	CH0MAX
		Write:	0							
		Reset:	0	0	0	0	0	0	0	0
\$0026	Timer 1 Channel 0 Register High (T1CH0H)	Read:	Bit 15	14	13	12	11	10	9	Bit 8
		Write:								
		Reset:	Indeterminate after reset							
\$0027	Timer 1 Channel 0 Register Low (T1CH0L)	Read:	Bit 7	6	5	4	3	2	1	Bit 0
		Write:								
		Reset:	Indeterminate after reset							
\$0028	Timer 1 Channel 1 Status and Control Register (T1SC1)	Read:	CH1F	CH1IE	0	MS1A	ELS1B	ELS1A	TOV1	CH1MAX
		Write:	0							
		Reset:	0	0	0	0	0	0	0	0

= Unimplemented

**Figure 11-2. TIM I/O Register Summary (Sheet 1 of 3)**

Freescale Semiconductor, Inc.

Timer Interface Module (TIM)

Addr.	Register Name	Bit 7	6	5	4	3	2	1	Bit 0	
\$0029	Timer 1 Channel 1 Register High (T1CH1H)	Read:	Bit 15	14	13	12	11	10	9	Bit 8
		Write:								
		Reset:	Indeterminate after reset							
\$002A	Timer 1 Channel 1 Register Low (T1CH1L)	Read:	Bit 7	6	5	4	3	2	1	Bit 0
		Write:								
		Reset:	Indeterminate after reset							
\$002B	Timer 2 Status and Control Register (T2SC)	Read:	TOF	TOIE	TSTOP	0	0	PS2	PS1	PS0
		Write:	0			TRST				
		Reset:	0	0	1	0	0	0	0	0
\$002C	Timer 2 Counter Register High (T2CNTH)	Read:	Bit 15	14	13	12	11	10	9	Bit 8
		Write:								
		Reset:	0	0	0	0	0	0	0	0
\$002D	Timer 2 Counter Register Low (T2CNTL)	Read:	Bit 7	6	5	4	3	2	1	Bit 0
		Write:								
		Reset:	0	0	0	0	0	0	0	0
\$002E	Timer 2 Counter Modulo Register High (T2MODH)	Read:	Bit 15	14	13	12	11	10	9	Bit 8
		Write:								
		Reset:	1	1	1	1	1	1	1	1
\$002F	Timer 2 Counter Modulo Register Low (T2MODL)	Read:	Bit 7	6	5	4	3	2	1	Bit 0
		Write:								
		Reset:	1	1	1	1	1	1	1	1
\$0030	Timer 2 Channel 0 Status and Control Register (T2SC0)	Read:	CH0F	CH0IE	MS0B	MS0A	ELS0B	ELS0A	TOV0	CH0MAX
		Write:	0							
		Reset:	0	0	0	0	0	0	0	0
\$0031	Timer 2 Channel 0 Register High (T2CH0H)	Read:	Bit 15	14	13	12	11	10	9	Bit 8
		Write:								
		Reset:	Indeterminate after reset							


 = Unimplemented

Figure 11-2. TIM I/O Register Summary (Sheet 2 of 3)

Addr.	Register Name	Bit 7	6	5	4	3	2	1	Bit 0	
\$0032	Timer 2 Channel 0 Register Low (T2CH0L)	Read:	Bit 7	6	5	4	3	2	1	Bit 0
		Write:								
		Reset:	Indeterminate after reset							
\$0033	Timer 2 Channel 1 Status and Control Register (T2SC1)	Read:	CH1F	CH1IE	0	MS1A	ELS1B	ELS1A	TOV1	CH1MAX
		Write:	0							
		Reset:	0	0	0	0	0	0	0	0
\$0034	Timer 2 Channel 1 Register High (T2CH1H)	Read:	Bit 15	14	13	12	11	10	9	Bit 8
		Write:								
		Reset:	Indeterminate after reset							
\$0035	Timer 2 Channel 1 Register Low (T2CH1L)	Read:	Bit 7	6	5	4	3	2	1	Bit 0
		Write:								
		Reset:	Indeterminate after reset							


 = Unimplemented

Figure 11-2. TIM I/O Register Summary (Sheet 3 of 3)

### 11.5.1 TIM Counter Prescaler

The TIM clock source can be one of the seven prescaler outputs or the TIM clock pin, TCLK. The prescaler generates seven clock rates from the internal bus clock. The prescaler select bits, PS[2:0], in the TIM status and control register select the TIM clock source.

### 11.5.2 Input Capture

With the input capture function, the TIM can capture the time at which an external event occurs. When an active edge occurs on the pin of an input capture channel, the TIM latches the contents of the TIM counter into the TIM channel registers, TCHxH:TCHxL. The polarity of the active edge is programmable. Input captures can generate TIM CPU interrupt requests.

### 11.5.3 Output Compare

With the output compare function, the TIM can generate a periodic pulse with a programmable polarity, duration, and frequency. When the counter reaches the value in the registers of an output compare channel, the TIM can set, clear, or toggle the channel pin. Output compares can generate TIM CPU interrupt requests.

#### 11.5.3.1 Unbuffered Output Compare

Any output compare channel can generate unbuffered output compare pulses as described in [11.5.3 Output Compare](#). The pulses are unbuffered because changing the output compare value requires writing the new value over the old value currently in the TIM channel registers.

An unsynchronized write to the TIM channel registers to change an output compare value could cause incorrect operation for up to two counter overflow periods. For example, writing a new value before the counter reaches the old value but after the counter reaches the new value prevents any compare during that counter overflow period. Also, using a TIM overflow interrupt routine to write a new, smaller output compare value may cause the compare to be missed. The TIM may pass the new value before it is written.

Use the following methods to synchronize unbuffered changes in the output compare value on channel x:

- When changing to a smaller value, enable channel x output compare interrupts and write the new value in the output compare interrupt routine. The output compare interrupt occurs at the end of the current output compare pulse. The interrupt routine has until the end of the counter overflow period to write the new value.
- When changing to a larger output compare value, enable TIM overflow interrupts and write the new value in the TIM overflow interrupt routine. The TIM overflow interrupt occurs at the end of the current counter overflow period. Writing a larger value in an output compare interrupt routine (at the end of the current pulse) could cause two output compares to occur in the same counter overflow period.



### 11.5.3.2 Buffered Output Compare

Channels 0 and 1 can be linked to form a buffered output compare channel whose output appears on the TCH0 pin. The TIM channel registers of the linked pair alternately control the output.

Setting the MS0B bit in TIM channel 0 status and control register (TSC0) links channel 0 and channel 1. The output compare value in the TIM channel 0 registers initially controls the output on the TCH0 pin. Writing to the TIM channel 1 registers enables the TIM channel 1 registers to synchronously control the output after the TIM overflows. At each subsequent overflow, the TIM channel registers (0 or 1) that control the output are the ones written to last. TSC0 controls and monitors the buffered output compare function, and TIM channel 1 status and control register (TSC1) is unused. While the MS0B bit is set, the channel 1 pin, TCH1, is available as a general-purpose I/O pin.

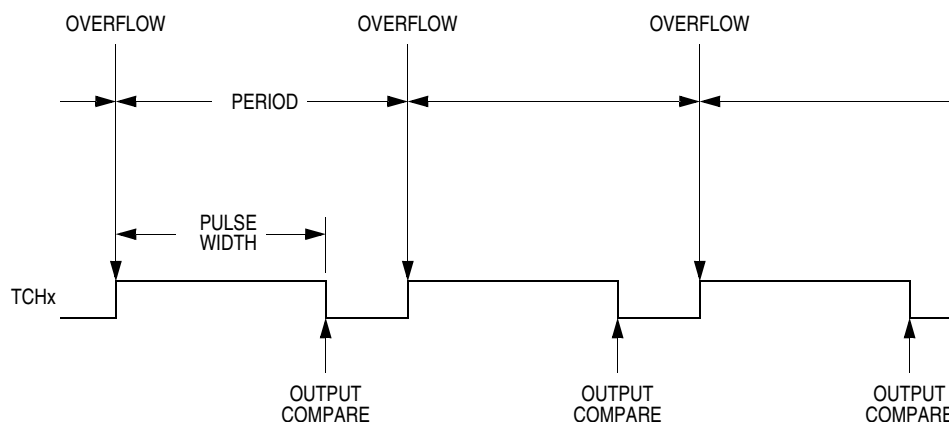
**NOTE:** *In buffered output compare operation, do not write new output compare values to the currently active channel registers. User software should track the currently active channel to prevent writing a new value to the active channel. Writing to the active channel registers is the same as generating unbuffered output compares.*

### 11.5.4 Pulse Width Modulation (PWM)

By using the toggle-on-overflow feature with an output compare channel, the TIM can generate a PWM signal. The value in the TIM counter modulo registers determines the period of the PWM signal. The channel pin toggles when the counter reaches the value in the TIM counter modulo registers. The time between overflows is the period of the PWM signal.

As **Figure 11-3** shows, the output compare value in the TIM channel registers determines the pulse width of the PWM signal. The time between overflow and output compare is the pulse width. Program the TIM to clear the channel pin on output compare if the state of the PWM pulse is logic 1. Program the TIM to set the pin if the state of the PWM pulse is logic 0.

The value in the TIM counter modulo registers and the selected prescaler output determines the frequency of the PWM output. The frequency of an 8-bit PWM signal is variable in 256 increments. Writing \$00FF (255) to the TIM counter modulo registers produces a PWM period of 256 times the internal bus clock period if the prescaler select value is \$000. See [11.10.1 TIM Status and Control Register](#).



**Figure 11-3. PWM Period and Pulse Width**

The value in the TIM channel registers determines the pulse width of the PWM output. The pulse width of an 8-bit PWM signal is variable in 256 increments. Writing \$0080 (128) to the TIM channel registers produces a duty cycle of 128/256 or 50%.

#### 11.5.4.1 Unbuffered PWM Signal Generation

Any output compare channel can generate unbuffered PWM pulses as described in [11.5.4 Pulse Width Modulation \(PWM\)](#). The pulses are unbuffered because changing the pulse width requires writing the new pulse width value over the old value currently in the TIM channel registers.

An unsynchronized write to the TIM channel registers to change a pulse width value could cause incorrect operation for up to two PWM periods. For example, writing a new value before the counter reaches the old value but after the counter reaches the new value prevents any compare during that PWM period. Also, using a TIM overflow interrupt routine to write a new, smaller pulse width value may cause the compare to be missed. The TIM may pass the new value before it is written.

Use the following methods to synchronize unbuffered changes in the PWM pulse width on channel x:

- When changing to a shorter pulse width, enable channel x output compare interrupts and write the new value in the output compare interrupt routine. The output compare interrupt occurs at the end of the current pulse. The interrupt routine has until the end of the PWM period to write the new value.
- When changing to a longer pulse width, enable TIM overflow interrupts and write the new value in the TIM overflow interrupt routine. The TIM overflow interrupt occurs at the end of the current PWM period. Writing a larger value in an output compare interrupt routine (at the end of the current pulse) could cause two output compares to occur in the same PWM period.

**NOTE:** *In PWM signal generation, do not program the PWM channel to toggle on output compare. Toggling on output compare prevents reliable 0% duty cycle generation and removes the ability of the channel to self-correct in the event of software error or noise. Toggling on output compare also can cause incorrect PWM signal generation when changing the PWM pulse width to a new, much larger value.*

#### 11.5.4.2 Buffered PWM Signal Generation

Channels 0 and 1 can be linked to form a buffered PWM channel whose output appears on the TCH0 pin. The TIM channel registers of the linked pair alternately control the pulse width of the output.

Setting the MS0B bit in TIM channel 0 status and control register (TSC0) links channel 0 and channel 1. The TIM channel 0 registers initially control the pulse width on the TCH0 pin. Writing to the TIM channel 1 registers enables the TIM channel 1 registers to synchronously control the pulse width at the beginning of the next PWM period. At each subsequent overflow, the TIM channel registers (0 or 1) that control the pulse width are the ones written to last. TSC0 controls and monitors the buffered PWM function, and TIM channel 1 status and control register (TSC1) is unused. While the MS0B bit is set, the channel 1 pin, TCH1, is available as a general-purpose I/O pin.

**NOTE:** *In buffered PWM signal generation, do not write new pulse width values to the currently active channel registers. User software should track the currently active channel to prevent writing a new value to the active channel. Writing to the active channel registers is the same as generating unbuffered PWM signals.*

#### 11.5.4.3 PWM Initialization

To ensure correct operation when generating unbuffered or buffered PWM signals, use the following initialization procedure:

1. In the TIM status and control register (TSC):
  - a. Stop the TIM counter by setting the TIM stop bit, TSTOP.
  - b. Reset the TIM counter and prescaler by setting the TIM reset bit, TRST.
2. In the TIM counter modulo registers (TMODH:TMODL), write the value for the required PWM period.
3. In the TIM channel x registers (TCHxH:TCHxL), write the value for the required pulse width.
4. In TIM channel x status and control register (TSCx):
  - a. Write 0:1 (for unbuffered output compare or PWM signals) or 1:0 (for buffered output compare or PWM signals) to the mode select bits, MSxB:MSxA. (See [Table 11-3.](#))
  - b. Write 1 to the toggle-on-overflow bit, TOVx.
  - c. Write 1:0 (to clear output on compare) or 1:1 (to set output on compare) to the edge/level select bits, ELSxB:ELSxA. The output action on compare must force the output to the complement of the pulse width level. (See [Table 11-3.](#))

**NOTE:** *In PWM signal generation, do not program the PWM channel to toggle on output compare. Toggling on output compare prevents reliable 0% duty cycle generation and removes the ability of the channel to self-correct in the event of software error or noise. Toggling on output compare can also cause incorrect PWM signal generation when changing the PWM pulse width to a new, much larger value.*

5. In the TIM status control register (TSC), clear the TIM stop bit, TSTOP.

Setting MS0B links channels 0 and 1 and configures them for buffered PWM operation. The TIM channel 0 registers (TCH0H:TCH0L) initially control the buffered PWM output. TIM channel 0 status and control register (TSC0) controls and monitors the PWM signal from the linked channels.

Clearing the toggle-on-overflow bit, TOVx, inhibits output toggles on TIM overflows. Subsequent output compares try to force the output to a state it is already in and have no effect. The result is a 0% duty cycle output.

Setting the channel x maximum duty cycle bit (CHxMAX) and setting the TOVx bit generates a 100% duty cycle output. (See [11.10.4 TIM Channel Status and Control Registers](#).)

## 11.6 Interrupts

The following TIM sources can generate interrupt requests:

- TIM overflow flag (TOF) — The TOF bit is set when the TIM counter reaches the modulo value programmed in the TIM counter modulo registers. The TIM overflow interrupt enable bit, TOIE, enables TIM overflow CPU interrupt requests. TOF and TOIE are in the TIM status and control register.
- TIM channel flags (CH1F:CH0F) — The CHxF bit is set when an input capture or output compare occurs on channel x. Channel x TIM CPU interrupt requests are controlled by the channel x interrupt enable bit, CHxIE. Channel x TIM CPU interrupt requests are enabled when CHxIE = 1. CHxF and CHxIE are in the TIM channel x status and control register.

## 11.7 Low-Power Modes

The WAIT and STOP instructions put the MCU in low power-consumption standby modes.

### 11.7.1 Wait Mode

The TIM remains active after the execution of a WAIT instruction. In wait mode, the TIM registers are not accessible by the CPU. Any enabled CPU interrupt request from the TIM can bring the MCU out of wait mode.

If TIM functions are not required during wait mode, reduce power consumption by stopping the TIM before executing the WAIT instruction.

### 11.7.2 Stop Mode

The TIM is inactive after the execution of a STOP instruction. The STOP instruction does not affect register conditions or the state of the TIM counter. TIM operation resumes when the MCU exits stop mode after an external interrupt.

## 11.8 TIM During Break Interrupts

A break interrupt stops the TIM counter.

The system integration module (SIM) controls whether status bits in other modules can be cleared during the break state. The BCFE bit in the SIM break flag control register (SBFCR) enables software to clear status bits during the break state. (See [9.8.3 SIM Break Flag Control Register](#).)

To allow software to clear status bits during a break interrupt, write a logic 1 to the BCFE bit. If a status bit is cleared during the break state, it remains cleared when the MCU exits the break state.

To protect status bits during the break state, write a logic 0 to the BCFE bit. With BCFE at logic 0 (its default state), software can read and write I/O registers during the break state without affecting status bits. Some status bits have a 2-step read/write clearing procedure. If software does the first step on such a bit before the break, the bit cannot change during the break state as long as BCFE is at logic 0. After the break, doing the second step clears the status bit.

## 11.9 I/O Signals

Port B shares four of its pins with the TIM channel I/O pins: T1CH0, T1CH1, T2CH0, and T2CH1.

Port D shares two of its pins with the TIM clock input pins: T1CLK and T2CLK

### 11.9.1 TIM Clock Pins (PTD4/KBI4/T1CLK, PTD5/KBI5/T2CLK)

T[1,2]CLK is an external clock input that can be the clock source for the TIM[1,2] counter instead of the prescaled internal bus clock. Select the T[1,2]CLK input by writing logic 1's to the three prescaler select bits, PS[2:0]. (See [11.10.1 TIM Status and Control Register](#).) The minimum T[1,2]CLK pulse width,  $T[1,2]CLK_{LMIN}$  or  $T[1,2]CLK_{HMIN}$ , is:

$$\frac{1}{\text{bus frequency}} + t_{SU}$$

The maximum T[1,2]CLK frequency is:

$$\text{bus frequency} \div 2$$

T1CLK and T2CLK are available as standard I/Os or KBI pins when not used as the TIM clock inputs.

### 11.9.2 TIM Channel I/O Pins (PTB2/T1CH0, PTB3/T1CH1, PTB4/T2CH0, PTB5/T2CH1)

Each channel I/O pin is programmable independently as an input capture pin or an output compare pin. T1CH0 and T2CH0 can be configured as buffered output compare or buffered PWM pins.

Timer Interface Module (TIM)

11.10 I/O Registers

**NOTE:** References to either timer 1 or timer 2 may be made in the following text by omitting the timer number. For example, TSC may generically refer to both T1SC AND T2SC.

These I/O registers control and monitor operation of the TIM:

- TIM status and control register (TSC)
- TIM counter registers (TCNTH:TCNTL)
- TIM counter modulo registers (TMODH:TMODL)
- TIM channel status and control registers (TSC0, TSC1)
- TIM channel registers (TCH0H:TCH0L, TCH1H:TCH1L)

11.10.1 TIM Status and Control Register

The TIM status and control register (TSC):

- Enables TIM overflow interrupts
- Flags TIM overflows
- Stops the TIM counter
- Resets the TIM counter
- Prescales the TIM counter clock

Address: T1SC, \$0020 and T2SC, \$002B

	Bit 7	6	5	4	3	2	1	Bit 0
Read:	TOF	TOIE	TSTOP	0	0	PS2	PS1	PS0
Write:	0			TRST				
Reset:	0	0	1	0	0	0	0	0


 = Unimplemented

Figure 11-4. TIM Status and Control Register (TSC)



**TOF — TIM Overflow Flag Bit**

This read/write flag is set when the TIM counter reaches the modulo value programmed in the TIM counter modulo registers. Clear TOF by reading the TIM status and control register when TOF is set and then writing a logic 0 to TOF. If another TIM overflow occurs before the clearing sequence is complete, then writing logic 0 to TOF has no effect. Therefore, a TOF interrupt request cannot be lost due to inadvertent clearing of TOF. Reset clears the TOF bit. Writing a logic 1 to TOF has no effect.

1 = TIM counter has reached modulo value

0 = TIM counter has not reached modulo value

**TOIE — TIM Overflow Interrupt Enable Bit**

This read/write bit enables TIM overflow interrupts when the TOF bit becomes set. Reset clears the TOIE bit.

1 = TIM overflow interrupts enabled

0 = TIM overflow interrupts disabled

**TSTOP — TIM Stop Bit**

This read/write bit stops the TIM counter. Counting resumes when TSTOP is cleared. Reset sets the TSTOP bit, stopping the TIM counter until software clears the TSTOP bit.

1 = TIM counter stopped

0 = TIM counter active

**NOTE:** *Do not set the TSTOP bit before entering wait mode if the TIM is required to exit wait mode.*

**TRST — TIM Reset Bit**

Setting this write-only bit resets the TIM counter and the TIM prescaler. Setting TRST has no effect on any other registers. Counting resumes from \$0000. TRST is cleared automatically after the TIM counter is reset and always reads as logic 0. Reset clears the TRST bit.

1 = Prescaler and TIM counter cleared

0 = No effect

**NOTE:** *Setting the TSTOP and TRST bits simultaneously stops the TIM counter at a value of \$0000.*

PS[2:0] — Prescaler Select Bits

These read/write bits select one of the seven prescaler outputs as the input to the TIM counter as Table 11-2 shows. Reset clears the PS[2:0] bits.

Table 11-2. Prescaler Selection

PS2	PS1	PS0	TIM Clock Source
0	0	0	Internal bus clock ÷ 1
0	0	1	Internal bus clock ÷ 2
0	1	0	Internal bus clock ÷ 4
0	1	1	Internal bus clock ÷ 8
1	0	0	Internal bus clock ÷ 16
1	0	1	Internal bus clock ÷ 32
1	1	0	Internal bus clock ÷ 64
1	1	1	TCLK

11.10.2 TIM Counter Registers

The two read-only TIM counter registers contain the high and low bytes of the value in the TIM counter. Reading the high byte (TCNTH) latches the contents of the low byte (TCNTL) into a buffer. Subsequent reads of TCNTH do not affect the latched TCNTL value until TCNTL is read. Reset clears the TIM counter registers. Setting the TIM reset bit (TRST) also clears the TIM counter registers.

**NOTE:** *If you read TCNTH during a break interrupt, be sure to unlatch TCNTL by reading TCNTL before exiting the break interrupt. Otherwise, TCNTL retains the value latched during the break.*

Address: T1CNTH, \$0021 and T2CNTH, \$002C

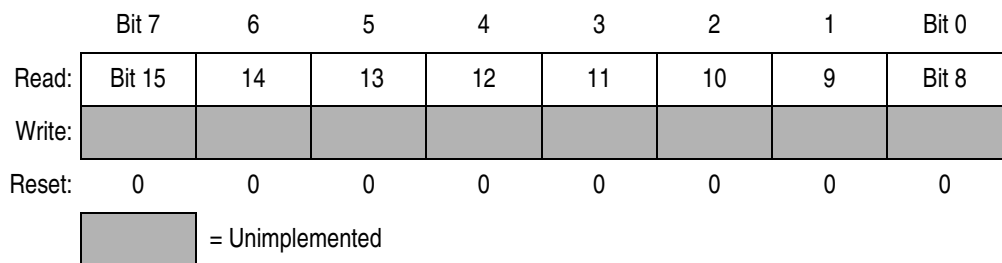



Figure 11-5. TIM Counter Registers High (TCNTH)

Address: T1CNTL, \$0022 and T2CNTL, \$002D

	Bit 7	6	5	4	3	2	1	Bit 0
Read:	Bit 7	6	5	4	3	2	1	Bit 0
Write:								
Reset:	0	0	0	0	0	0	0	0

 = Unimplemented

**Figure 11-6. TIM Counter Registers Low (TCNTL)**

### 11.10.3 TIM Counter Modulo Registers

The read/write TIM modulo registers contain the modulo value for the TIM counter. When the TIM counter reaches the modulo value, the overflow flag (TOF) becomes set, and the TIM counter resumes counting from \$0000 at the next timer clock. Writing to the high byte (TMODH) inhibits the TOF bit and overflow interrupts until the low byte (TMODL) is written. Reset sets the TIM counter modulo registers.

Address: T1MODH, \$0023 and T2MODH, \$002E

	Bit 7	6	5	4	3	2	1	Bit 0
Read:	Bit 15	14	13	12	11	10	9	Bit 8
Write:								
Reset:	1	1	1	1	1	1	1	1

**Figure 11-7. TIM Counter Modulo Register High (TMODH)**

Address: T1MODL, \$0024 and T2MODL, \$002F

	Bit 7	6	5	4	3	2	1	Bit 0
Read:	Bit 7	6	5	4	3	2	1	Bit 0
Write:								
Reset:	1	1	1	1	1	1	1	1

**Figure 11-8. TIM Counter Modulo Register Low (TMODL)**

**NOTE:** *Reset the TIM counter before writing to the TIM counter modulo registers.*

11.10.4 TIM Channel Status and Control Registers

Each of the TIM channel status and control registers:

- Flags input captures and output compares
- Enables input capture and output compare interrupts
- Selects input capture, output compare, or PWM operation
- Selects high, low, or toggling output on output compare
- Selects rising edge, falling edge, or any edge as the active input capture trigger
- Selects output toggling on TIM overflow
- Selects 0% and 100% PWM duty cycle
- Selects buffered or unbuffered output compare/PWM operation

Address: T1SC0, \$0025 and T2SC0, \$0030

	Bit 7	6	5	4	3	2	1	Bit 0
Read:	CH0F	CH0IE	MS0B	MS0A	ELS0B	ELS0A	TOV0	CH0MAX
Write:	0							
Reset:	0	0	0	0	0	0	0	0

Figure 11-9. TIM Channel 0 Status and Control Register (TSC0)

Address: T1SC1, \$0028 and T2SC1, \$0033

	Bit 7	6	5	4	3	2	1	Bit 0
Read:	CH1F	CH1IE	0	MS1A	ELS1B	ELS1A	TOV1	CH1MAX
Write:	0							
Reset:	0	0	0	0	0	0	0	0

= Unimplemented

Figure 11-10. TIM Channel 1 Status and Control Register (TSC1)

**CHxF — Channel x Flag Bit**

When channel x is an input capture channel, this read/write bit is set when an active edge occurs on the channel x pin. When channel x is an output compare channel, CHxF is set when the value in the TIM counter registers matches the value in the TIM channel x registers.

When TIM CPU interrupt requests are enabled (CHxIE = 1), clear CHxF by reading TIM channel x status and control register with CHxF set and then writing a logic 0 to CHxF. If another interrupt request occurs before the clearing sequence is complete, then writing logic 0 to CHxF has no effect. Therefore, an interrupt request cannot be lost due to inadvertent clearing of CHxF.

Reset clears the CHxF bit. Writing a logic 1 to CHxF has no effect.

- 1 = Input capture or output compare on channel x
- 0 = No input capture or output compare on channel x

**CHxIE — Channel x Interrupt Enable Bit**

This read/write bit enables TIM CPU interrupt service requests on channel x.

Reset clears the CHxIE bit.

- 1 = Channel x CPU interrupt requests enabled
- 0 = Channel x CPU interrupt requests disabled

**MSxB — Mode Select Bit B**

This read/write bit selects buffered output compare/PWM operation. MSxB exists only in the TIM1 channel 0 and TIM2 channel 0 status and control registers.

Setting MS0B disables the channel 1 status and control register and reverts TCH1 to general-purpose I/O.

Reset clears the MSxB bit.

- 1 = Buffered output compare/PWM operation enabled
- 0 = Buffered output compare/PWM operation disabled

**MSxA — Mode Select Bit A**

When ELSxB:ELSxA  $\neq$  0:0, this read/write bit selects either input capture operation or unbuffered output compare/PWM operation.

See [Table 11-3](#).

- 1 = Unbuffered output compare/PWM operation
- 0 = Input capture operation

When ELSxB:ELSxA = 0:0, this read/write bit selects the initial output level of the TCHx pin. See [Table 11-3](#). Reset clears the MSxA bit.

- 1 = Initial output level low
- 0 = Initial output level high

**NOTE:** Before changing a channel function by writing to the MSxB or MSxA bit, set the TSTOP and TRST bits in the TIM status and control register (TSC).

ELSxB and ELSxA — Edge/Level Select Bits

When channel x is an input capture channel, these read/write bits control the active edge-sensing logic on channel x.

When channel x is an output compare channel, ELSxB and ELSxA control the channel x output behavior when an output compare occurs.

When ELSxB and ELSxA are both clear, channel x is not connected to an I/O port, and pin TCHx is available as a general-purpose I/O pin. [Table 11-3](#) shows how ELSxB and ELSxA work. Reset clears the ELSxB and ELSxA bits.

**Table 11-3. Mode, Edge, and Level Selection**

MSxB:MSxA	ELSxB:ELSxA	Mode	Configuration
X0	00	Output preset	Pin under port control; initial output level high
X1	00		Pin under port control; initial output level low
00	01	Input capture	Capture on rising edge only
00	10		Capture on falling edge only
00	11		Capture on rising or falling edge
01	01	Output compare or PWM	Toggle output on compare
01	10		Clear output on compare
01	11		Set output on compare
1X	01	Buffered output compare or buffered PWM	Toggle output on compare
1X	10		Clear output on compare
1X	11		Set output on compare

**NOTE:** Before enabling a TIM channel register for input capture operation, make sure that the TCHx pin is stable for at least two bus clocks. User software should also clear CHxF before setting CHxIE to avoid any false interrupts.

**TOVx — Toggle On Overflow Bit**

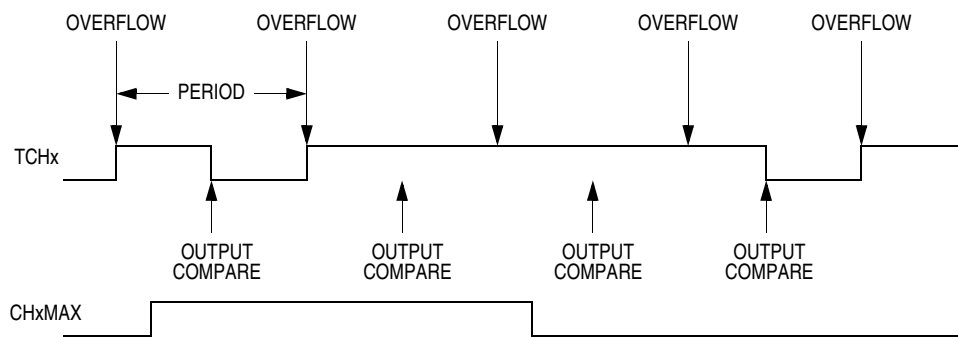
When channel x is an output compare channel, this read/write bit controls the behavior of the channel x output when the TIM counter overflows. When channel x is an input capture channel, TOVx has no effect. Reset clears the TOVx bit.

- 1 = Channel x pin toggles on TIM counter overflow
- 0 = Channel x pin does not toggle on TIM counter overflow

**NOTE:** When TOVx is set, a TIM counter overflow takes precedence over a channel x output compare if both occur at the same time.

**CHxMAX — Channel x Maximum Duty Cycle Bit**

When the TOVx bit is at logic 1, setting the CHxMAX bit forces the duty cycle of buffered and unbuffered PWM signals to 100%. As **Figure 11-11** shows, the CHxMAX bit takes effect in the cycle after it is set or cleared. The output stays at the 100% duty cycle level until the cycle after CHxMAX is cleared.



**Figure 11-11. CHxMAX Latency**

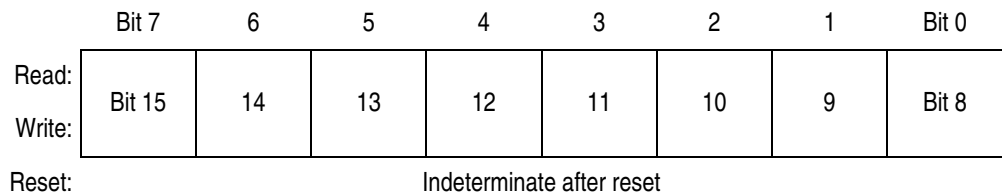
**11.10.5 TIM Channel Registers**

These read/write registers contain the captured TIM counter value of the input capture function or the output compare value of the output compare function. The state of the TIM channel registers after reset is unknown.

In input capture mode ( $MSxB:MSxA = 0:0$ ), reading the high byte of the TIM channel x registers (TCHxH) inhibits input captures until the low byte (TCHxL) is read.

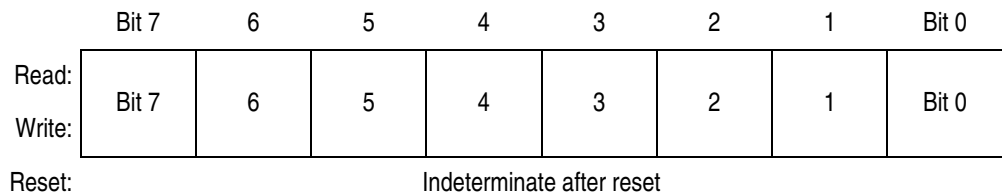
In output compare mode ( $MSxB:MSxA \neq 0:0$ ), writing to the high byte of the TIM channel x registers (TCHxH) inhibits output compares until the low byte (TCHxL) is written.

Address: T1CH0H, \$0026 and T2CH0H, \$0031



**Figure 11-12. TIM Channel 0 Register High (TCH0H)**

Address: T1CH0L, \$0027 and T2CH0L \$0032



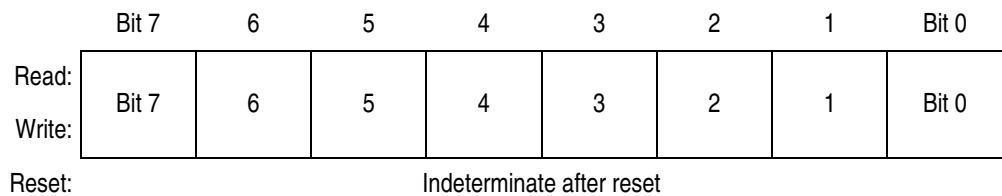
**Figure 11-13. TIM Channel 0 Register Low (TCH0L)**

Address: T1CH1H, \$0029 and T2CH1H, \$0034



**Figure 11-14. TIM Channel 1 Register High (TCH1H)**

Address: T1CH1L, \$002A and T2CH1L, \$0035



**Figure 11-15. TIM Channel 1 Register Low (TCH1L)**



## Section 12. Real Time Clock (RTC)

### 12.1 Contents

12.2	Introduction	218
12.3	Features	218
12.4	I/O Pins	219
12.5	Functional Description	221
12.5.1	Time Functions	223
12.5.2	Calendar Functions	223
12.5.3	Alarm Functions	223
12.5.4	Chronograph Functions	223
12.5.5	Timebase Interrupts	224
12.6	RTC Interrupts	224
12.7	RTC Clock Calibration and Compensation	225
12.7.1	Calibration Error	226
12.8	RTC Register and Bit Write Protection	227
12.9	Low-Power Modes	229
12.9.1	Wait Mode	229
12.9.2	Stop Mode	230
12.10	RTC Registers	230
12.10.1	RTC Calibration Control Register (RTCCOMR)	231
12.10.2	RTC Calibration Data Register (RTCCDAT)	233
12.10.3	RTC Control Register 1 (RTCCR1)	234
12.10.4	RTC Control Register 2 (RTCCR2)	235
12.10.5	RTC Status Register (RTCSR)	237
12.10.6	Alarm Minute and Hour Registers (ALMR and ALHR)	240
12.10.7	Second Register (SECR)	241
12.10.8	Minute Register (MINR)	241
12.10.9	Hour Register (HRR)	242

12.10.10 Day Register (DAYR) .....	242
12.10.11 Month Register (MTHR) .....	243
12.10.12 Year Register (YRR) .....	243
12.10.13 Day-Of-Week Register (DOWR) .....	244
12.10.14 Chronograph Data Register (CHRR) .....	244

## 12.2 Introduction

This section describes the real time clock (RTC) module. The RTC provides real time clock and calendar functions with automatic leap year adjustments. Other functions include alarm interrupt, periodic interrupts, and a chronograph timer.

**NOTE:** *This module is designed for a 32.768-kHz oscillator.*

## 12.3 Features

Features of the RTC module include:

- 32.768 kHz clock input with frequency compensation
- Counter registers for:
  - Second
  - Minute
  - Hour
  - Day
  - Day-of-week
  - Month
  - Year
- Day counter with automatic month and leap year adjustment
- 1/100 seconds chronograph counter
- Seven periodic interrupts
- Alarm interrupt

12.4 I/O Pins

Two RTC clock calibration pins are shared with standard port I/O pins.

Table 12-1. Pin Name Conventions

RTC Generic Pin Name	Full MCU Pin Name	Pin Selected for RTC Function by Bits in RTCCOMR (\$0040)
CALIN	PTD0/ $\overline{SS}$ /CALIN	AUTOCAL
CALOUT	PTD3/SPSCK/CALOUT <sup>(1)</sup>	OUTF[1:0]

Notes:

1. Do not enable the SPI function if the pin is used for RTC calibration.

Addr.	Register Name	Bit 7	6	5	4	3	2	1	Bit 0	
\$0040	RTC Calibration Control Register (RTCCOMR)	Read:	0	0	CAL	AUTOCAL	OUTF1	OUTF0	0	0
		Write:	R	R					RTCWE1	RTCWE0
		Reset:	0	0	0	0	0	0	0	0
\$0041	RTC Calibration Data Register (RTCCDAT)	Read:	EOVL	0	E5	E4	E3	E2	E1	E0
		Write:								
		Reset:	U	0	U	U	U	U	U	U
\$0042	RTC Control Register 1 (RTCCR1)	Read:	ALMIE	CHRIE	DAYIE	HRIE	MINIE	SECIE	TB1IE	TB2IE
		Write:								
		Reset:	0	0	0	0	0	0	0	0
\$0043	RTC Control Register 2 (RTCCR2)	Read:	COMEN	0	CHRE	RTCE	TBH	0	0	0
		Write:		CHRCLR						
		Reset:	U	0	0	0 <sup>††</sup>	0	0	0	0
\$0044	RTC Status Register (RTCSR)	Read:	ALMF	CHRF	DAYF	HRF	MINF	SECF	TB1F	TB2F
		Write:								
		Reset:	0	0	0	0	0	0	0	0
\$0045	Alarm Minute Register (ALMR)	Read:	0	0	AM5	AM4	AM3	AM2	AM1	AM0
		Write:								
		Reset:	0	0	U	U	U	U	U	U

†† Reset by POR only.

U = Unaffected       = Unimplemented      R = Reserved

Figure 12-1. RTC I/O Register Summary

Real Time Clock (RTC)

\$0046	Alarm Hour Register (ALHR)	Read:	0	0	0	AH4	AH3	AH2	AH1	AH0
		Write:								
		Reset:	0	0	0	U	U	U	U	U
\$0047	Second Register (SECR)	Read:	0	0	SEC5	SEC4	SEC3	SEC2	SEC1	SEC0
		Write:								
		Reset:	0	0	U	U	U	U	U	U
\$0048	Minute Register (MINR)	Read:	0	0	MIN5	MIN4	MIN3	MIN2	MIN1	MIN0
		Write:								
		Reset:	0	0	U	U	U	U	U	U
\$0049	Hour Register (HRR)	Read:	0	0	0	HR4	HR3	HR2	HR1	HR0
		Write:								
		Reset:	0	0	0	U	U	U	U	U
\$004A	Day Register (DAYR)	Read:	0	0	0	DAY4	DAY3	DAY2	DAY1	DAY0
		Write:								
		Reset:	0	0	0	U	U	U	U	U
\$004B	Month Register (MTHR)	Read:	0	0	0	0	MTH3	MTH2	MTH1	MTH0
		Write:								
		Reset:	0	0	0	0	U	U	U	U
\$004C	Year Register (YRR)	Read:								
		Write:	YR7	YR6	YR5	YR4	YR3	YR2	YR1	YR0
		Reset:	U	U	U	U	U	U	U	U
\$004D	Day-Of-Week Register (DOWR)	Read:	0	0	0	0	0	DOW2	DOW1	DOW0
		Write:								
		Reset:	0	0	0	0	0	0	U	U
\$004E	Chronograph Data Register (CHRR)	Read:	0	CHR6	CHR5	CHR4	CHR3	CHR2	CHR1	CHR0
		Write:								
		Reset:	0	0	0	0	0	0	0	0

U = Unaffected       = Unimplemented      R = Reserved

Figure 12-1. RTC I/O Register Summary

## 12.5 Functional Description

The RTC module provides clock indications in seconds, minutes, and hours; calendar indications in day-of-week, day-of-month, month, and year; with automatic adjustment for month and leap year. Reading the clock and calendar registers return the current time and date. Writing to these registers set the time and date, and the counters will continue to count from the new settings.

The alarm interrupt is set for the hour and minute. When the hour and minute counters matches the time set in the alarm hour and minute registers, the alarm flag is set. The alarm can be configured to generate a CPU interrupt request.

A 1/100 seconds chronograph counter is provided for timing applications. This counter can be independently enabled or disabled, and cleared at any time.

RTC module interrupts include the alarm interrupt and seven periodic interrupts from the clock and chronograph counters.

A frequency compensation mechanism is built into this RTC module to allow adjustments made to the RTC clock when a less accurate 32.768kHz crystal is used.

The 1-Hz clock that drives the clock and calendar could make use of the built-in compensation mechanism for crystal frequency error compensation so that the 1-Hz clock could be made more accurate than the frequency accuracy of the crystal that drive the module. The compensation value can be provided by application software or acquire automatically during calibration operation of the module.

**Figure 12-2** shows the structure of the RTC module.

Real Time Clock (RTC)

Freescale Semiconductor, Inc.

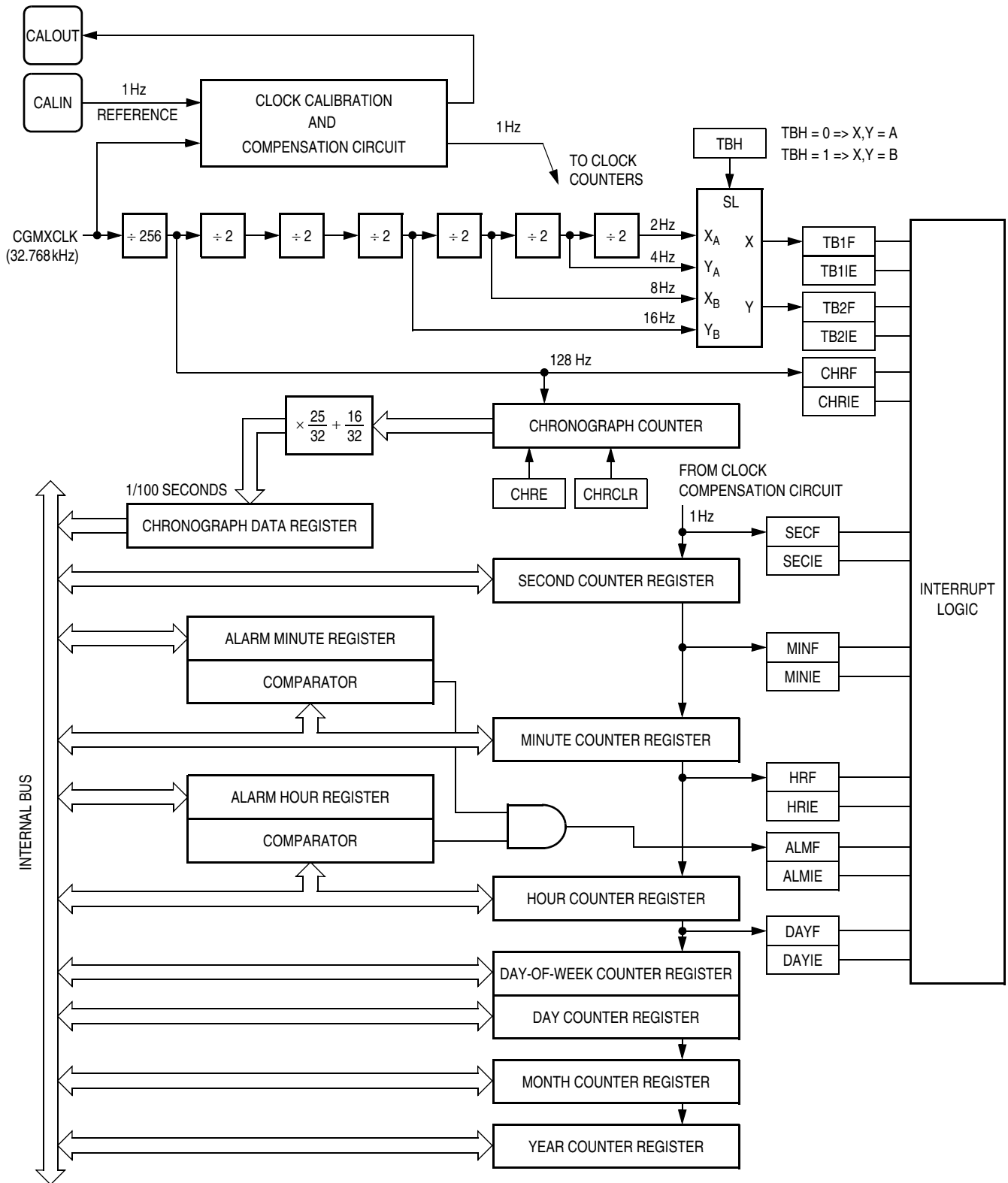


Figure 12-2. RTC Block Diagram

### 12.5.1 Time Functions

Real time clock functions are provided by the second, minute, and hour counter registers. All three clock counters are able to generate interrupts on every counter increment, providing periodic interrupts for the second (SECF), minute (MINF), and hour (HRF). A CPU interrupt request is generated if the corresponding enable bit (SECIE, MINIE, and HRIE) is also set.

### 12.5.2 Calendar Functions

Calendar functions are provided by the day, day-of-week, month, and year counter registers. The roll over of the day counter is automatically adjusted for the month and leap years. The setting for the year counter ranges from 1901 to 2099.

The day flag (DAYF) is set on every increment of the day counter. A CPU interrupt request is generated if the day interrupt enable bit (DAYIE) is also set.

### 12.5.3 Alarm Functions

An alarm function is provided for the minute and hour counters. When minute counter matches the value stored in the alarm minute register, and the hour counter matches the value stored in the alarm hour register, the alarm flag (ALMF) will be set. A CPU interrupt request is generated if the alarm interrupt enable bit (ALMIE) is also set.

### 12.5.4 Chronograph Functions

The chronograph function is provided by a counter clocked at 128Hz (CGMXCLK/256). This counter can be started, stopped, and cleared at any time. The value of this chronograph counter is converted to 100Hz resolution and stored in the chronograph data register. Hence, the value in the chronograph register counts from 0 to 99 (and rolls over), with each increment representing 1/100th of a second (10ms).

The value in the chronograph data register satisfies the following equation:

$$\frac{(128\text{Hz counter value} \times 25) + 16}{32}$$

The accuracy of the chronograph counter is  $\pm 5\text{ms}$  (max).

### 12.5.5 Timebase Interrupts

In addition to the second, minute, hour, and day periodic interrupts generated by the clock functions, the divider circuits generates four periodic clocks, separated into two groups: 2Hz and 4Hz; 8Hz and 16Hz. The TBH bit in the RTC control register 2 (RTCCR2) selects the group for the timebase interrupts, indicated by TB1F and TB2F flags. A CPU interrupt request is generated if the corresponding enable bits (TB1IE and TB2IE) are also set.

## 12.6 RTC Interrupts

The RTC has one alarm interrupt and seven periodic interrupts:

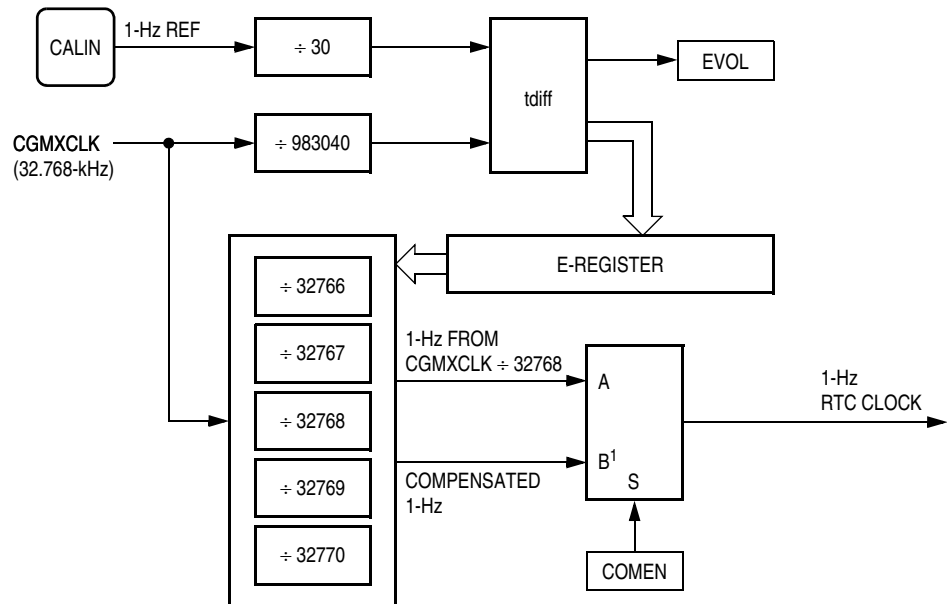
- Alarm interrupt
- Periodic interrupts:
  - Second
  - Minute
  - Hour
  - Day
  - 1/128 seconds (chronograph)
  - Timebase 1 and 2:
    - 1/2 seconds and 1/4 seconds, or
    - 1/8 seconds and 1/16 seconds

A CPU interrupt request is generated if the corresponding interrupt enable bits are also set.



## 12.7 RTC Clock Calibration and Compensation

The RTC module is built with a calibration and compensation circuit for the CGMXCLK. The circuit is used to compensate frequency errors of the 32.768kHz crystal so that a more accurate 1-Hz RTC clock can be achieved. Using this method, it is possible to use a less expensive crystal. If the crystal temperature profile and the current temperature is known, the calibration circuit can also be used to compensate crystal frequency errors due to ambient temperature change and crystal aging. The circuit provides a  $\pm 60$ ppm compensation range, which is suitable for common 30ppm crystals, and can achieve a compensated RTC clock accuracy between  $-3$ ppm and  $+2$ ppm.



**Figure 12-3. RTC Clock Calibration and Compensation**

The automatic calibration process works by comparing an external 1-Hz (1 ppm) signal driven into the CALIN pin, with the CGMXCLK signal driven by the 32.768kHz crystal. The calibration is started by setting the CAL bit followed by the AUTOCAL bit in the RTC calibration register (RTCCOMR). During calibration, the tdiff block compares the time difference between the two clock sources for 15 seconds. This time difference is expressed in the number of CGMXCLK clock cycles and stored in two's complement format in the 6-bit E-register (the RTC calibration data register, RTCCDAT).

A negative E-value indicates the number of CGMXCLK cycles that needs to be subtracted, because the CGMXCLK is slower than the ideal 32.768kHz; 32768 CGMXCLK cycles will be more longer than 1-second.

A positive E-value indicates the number of CGMXCLK cycles that needs to be added, because the CGMXCLK is faster than the ideal 32.768kHz; 32768 CGMXCLK cycles will be more shorter than 1-second.

If the time difference is more than 31 CGMXCLK cycles, the E-register will overflow, causing the EVOL flag to be set. The maximum (+30) or minimum (-30) value will remain in the E-register.

After calibration, with the E-value stored in the calibration data register, clock compensation is only enabled when the COMEN bit is set in RTCCR2. As the E-value is the time difference for 15 seconds, the CGMXCLK is modified for every 15-second intervals. The CGMXCLK additions and subtractions are simulated using programmable dividers, therefore, the compensated clock does not have the same period within the 15-second, but is consistent for every 15-second periods. See [Table 12-2](#) and [Figure 12-4](#).

### 12.7.1 Calibration Error

During clock calibration, the reference signal to the CALIN pin is not synchronized to the CGMXCLK being measured. A maximum inaccuracy of minus  $1.5 \times$ CGMXCLK period or plus  $1 \times$ CGMXCLK period will be introduced to the time difference measured.

**Table 12-2. Compensation Algorithm for Different Values of E**

E	Period A		Period B	
	Number of CGMXCLK Cycles	CGMXCLK Divider A	Number of CGMXCLK Cycles	CGMXCLK Divider B
$-30 \leq E \leq -16$	$( E  - 15) \times 32766$	32766	$(30 -  E ) \times 32767$	32767
$-15 \leq E \leq -1$	$ E  \times 32767$	32767	$(15 -  E ) \times 32768$	32768
$E = 0$	No compensation is required: Divider is 32768 throughout.			
$1 \leq E \leq 15$	$ E  \times 32769$	32769	$(15 -  E ) \times 32768$	32769
$16 \leq E \leq 30$	$( E  - 15) \times 32770$	32770	$(30 -  E ) \times 32769$	32769

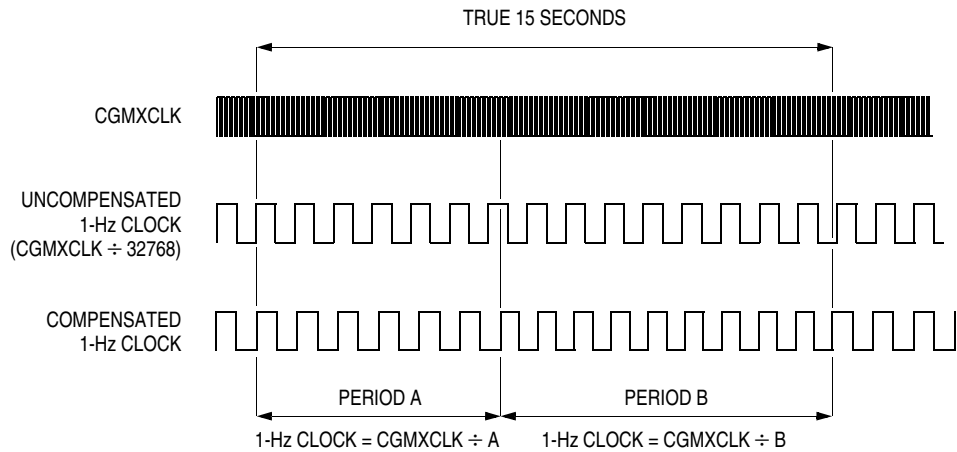


Figure 12-4. 1-Hz Clock Compensation

## 12.8 RTC Register and Bit Write Protection

A write-protect mechanism is implemented to prevent accidental writes to the RTC clock registers, calendar registers, and other control bits. The protected RTC registers and bits are listed in [Table 12-3](#).

Table 12-3. Write-Protected RTC Registers and Bits

Register	Bit
RTC Control Register 1	CAL
	AUTOCAL
	OUTF[1:0]
RTC Control Register 2	COMEN
	RTCE
Second Register	(All Bits)
Minute Register	(All Bits)
Hour Register	(All Bits)
Day-Of-Week Register	(All Bits)
Day Register	(All Bits)
Month Register	(All Bits)
Year Register	(All Bits)

The mechanism uses the RTCWE[1:0] bits in the RTC calibration control register (RTCCOMR) in a state machine, which requires a bit-write sequence to disable the write-protection. A block diagram of the state machine is shown in [Figure 12-5](#).

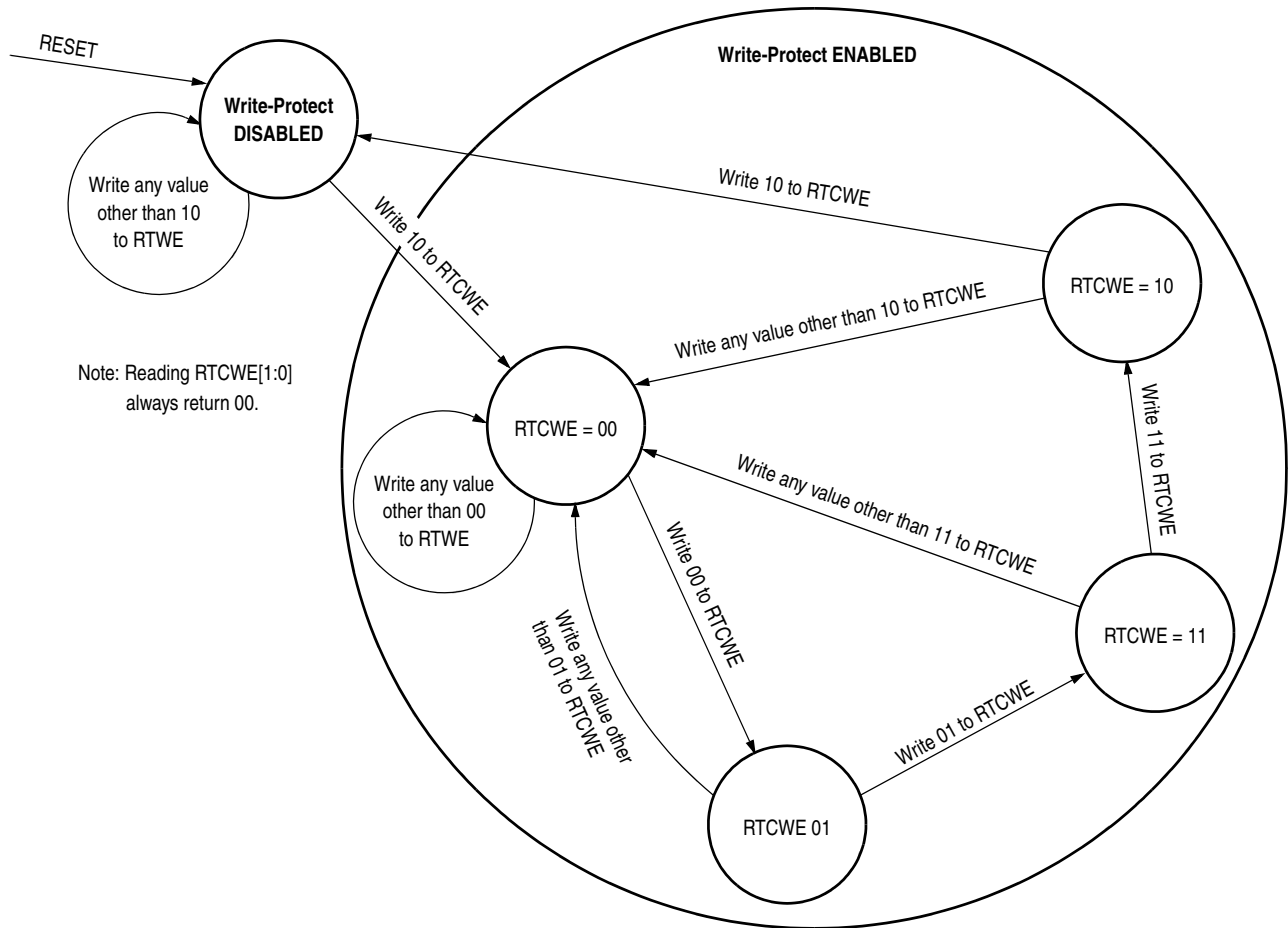


Figure 12-5. RTC Write Protect State Diagram

After a reset, the write-protect mechanism is disabled, allowing the user code to calibrate the RTC clock, set the time in the clock registers, and set the date in the calendar registers.

To enable write-protect after reset or write-protect is disabled execute the following code:

```
RTCWE1 EQU 1 ;RTCWE1 bit
RTCWE0 EQU 0 ;RTCWE0 bit
```

```
RTCWE_REQU    $40    ;RTCCOMR register
...
RTC_WRTIE_PROTECT    BSET  RTCWE1,RTCWE_R ;write %10
                    BSET  RTCWE1,RTCWE_R ;write %10 again
...
```

To disable write-protect after write-protect is enabled execute the following code:

```
RTCWE1 EQU    1    ;RTCWE1 bit
RTCWE0 EQU    0    ;RTCWE0 bit
RTCWE_REQU    $40    ;RTCCOMR register
...
RTC_WRITE_ENABLE    BSET  RTCWE1,RTCWE_R ;write %10 twice to
                    BSET  RTCWE1,RTCWE_R ;ensure protected
...
                    BCLR  RTCWE1,RTCWE_R ;write %00
                    BSET  RTCWE0,RTCWE_R ;write %01
                    LDA   RTCWE_R
                    ORA   #%00000011
                    STA   RTCWE_R      ;write %11
                    BSET  RTCWE1,RTCWE_R ;write %10
...
; Write-protect is disabled, RTC registers/bits can be written.
...
; Protect register/bits again after write access.
RTC_WRTIE_PROTECT    BSET  RTCWE1,RTCWE_R ;write %10
                    BSET  RTCWE1,RTCWE_R ;write %10 again
...
```

## 12.9 Low-Power Modes

The STOP and WAIT instructions put the MCU in low power-consumption standby modes.

### 12.9.1 Wait Mode

The RTC module continues normal operation in wait mode. Any enabled CPU interrupt request from the RTC can bring the MCU out of wait mode. If the RTC is not required to bring the MCU out of wait mode, power down the RTC by clearing the RTCE bit before executing the WAIT instruction.

### 12.9.2 Stop Mode

For continuous RTC operation in stop mode, the oscillator stop mode enable bit (STOP\_XCLKEN in CONFIG2 register) must be set before executing the STOP instruction. When STOP\_XCLKEN is set, CGMXCLK continues to drive the RTC module, and any enabled CPU interrupt request from the RTC can bring the MCU out of stop mode.

If STOP\_XCLKEN bit is cleared, the RTC module is inactive after the execution of a STOP instruction. The STOP instruction does not affect RTC register states. RTC module operation resumes after an external interrupt. To further reduce power consumption, the RTC module should be powered-down by clearing the RTCE bit before executing the STOP instruction.

## 12.10 RTC Registers

The RTC module has fifteen memory-mapped registers:

- RTC calibration control register (RTCCOMR)
- RTC calibration data register (RTCCDAT)
- RTC control register 1 (RTCCR1)
- RTC control register 2 (RTCCR2)
- RTC status register (RTCSR)
- Alarm minute and hour registers (ALMR and ALHR)
- Second register (SECR)
- Minute register (MINR)
- Hour register (HRR)
- Day register (DAY)
- Month register (MTHR)
- Year register (YRR)
- Day of the week register (DOWR)
- Chronograph data register (CHRR)

12.10.1 RTC Calibration Control Register (RTCCOMR)

The RTC calibration control register (RTCCOMR) contains control bits for RTC calibration, output option for the CALOUT pin, and registers/bits write-protect enable.

Address: \$0040

Read:	0	0	CAL*	AUTOCAL*	OUTF1*	OUTF0*	0	0
Write:	R	R					RTCWE1	RTCWE0
Reset:	0	0	0	0	0	0	0	0

\* CAL, AUTOCAL, and OUTF{1:0} bits are write-protected; unprotect by a write sequence to RTCWE[1:0].

Figure 12-6. RTC Calibration Control Register (RTCCOMR)

CAL — RTC Calibration Mode

This read/write bit enables the RTC calibration circuit. The CAL bit is cleared automatically after completion of automatic calibration if AUTOCAL is also set when CAL bit is set.

- 1 = RTC calibration mode enabled
- 0 = RTC calibration mode disabled

AUTOCAL — RTC Automatic Calibration Enable

This read/write bit enables the CALIN pin to accept an incoming 1-Hz signal and calibration circuits for RTC automatic calibration. This bit can only be set when the CAL bit is set. After calibration (approx. 15 seconds), the AUTOCAL bit is automatically cleared.

- 1 = RTC automatic calibration enabled
- 0 = RTC automatic calibration disabled

**NOTE:** *RTC clock and calendar functions are not affected when calibration is enabled.*

OUTF[1:0] — Calibration Mode CALOUT Pin Output Selection

These two bits select the output option for the CALOUT pin. When CAL = 0, OUTF[1:0] is always 00.

**Table 12-4. CALOUT Pin Output Option**

OUTF[1:0]	CALOUT Pin Output
00	CALOUT pin is disconnected.
01	CALOUT pin outputs compensated 1-Hz.
10	CALOUT pin outputs CGMXCLK clock.
11	Reserved

RTCWE[1:0] — RTC Module Write Enable

These two write-only bits control the write-protect function of several RTC registers and bits. After a reset, write-protect is disabled, allowing full write access to RTC registers and bits. These two bits always read as 0.

To enable write-protect, perform the following sequence:

1. Write %10 to RTCWE[1:0] bits
2. Write %10 to RTCWE[1:0] bits

To disable write-protect, perform the following sequence:

1. Write %00 to RTCWE[1:0] bits
2. Write %01 to RTCWE[1:0] bits
3. Write %11 to RTCWE[1:0] bits
4. Write %10 to RTCWE[1:0] bits

To disable write-protect from an unsure protection state, first perform the enable write-protect sequence, followed by the disable write-protect sequence.



12.10.2 RTC Calibration Data Register (RTCCDAT)

The RTC calibration data register (RTCCDAT) contains the RTC calibration data.

Address: \$0041

Read:	EOVL	0	E5	E4	E3	E2	E1	E0
Write:								
Reset:	U	0	U	U	U	U	U	U

Figure 12-7. RTC Calibration Data Register (RTCCDAT)

EOVL — E Register Overflow

This read-only bit indicates that the time difference recorded between CALIN and CGMXCLK after 15 seconds during the last automatic calibration had exceeded 31 CGMXCLK cycles. Clear this flag by writing to the E register after the CAL bit is set. Setting the AUTOCAL bit will also clear this flag, but subsequent automatic calibration may set this flag again.

- 1 = E register overflow detected during the last automatic calibration
- 0 = No E register overflow detected during last automatic calibration

E[5:0] — RTC Compensation Value (E register)

E[5:0] is a two’s complement number which indicates the number of CGMXCLK cycles the RTC requires to compensate for a 15 second duration. If the compensation exceeds the limit of ±31 CGMXCLK cycles, the E[5:0] bits remain at the maximum value of -30 (%100010) or +30 (%011110), and the EOVL flag will be set.

When compensation is enabled (COMEN = 1): If E is negative, an E number of cycles will be subtracted from the 491520 CGMXCLK cycles (32768 × 15).

When compensation is enabled (COMEN = 1): If E is positive, an E number of cycles will be added to the 491520 CGMXCLK cycles (32768 × 15).

E[5:0] is written by the RTC compensation circuit during automatic calibration (AUTOCAL = 1). User can only write to E[5:0] when AUTOCAL = 0 and CAL = 1. Reset has no effect on E[1:0] bits.

12.10.3 RTC Control Register 1 (RTCCR1)

The RTC control register 1 (RTCCR1) contains the eight interrupt enable bits for RTC interrupt functions.

Address: \$0042

Read:	ALMIE	CHRIE	DAYIE	HRIE	MINIE	SECIE	TB1IE	TB2IE
Write:								
Reset:	0	0	0	0	0	0	0	0

Figure 12-8. RTC Control Register 1 (RTCCR1)

ALMIE — Alarm Interrupt Enable

This read/write bit enables the alarm flag, ALMF, to generate CPU interrupt requests. Reset clears the ALMIE bit.

- 1 = ALMF enabled to generate CPU interrupt
- 0 = ALMF not enabled to generate CPU interrupt

CHRIE — Chronograph Interrupt Enable

This read/write bit enables the chronograph flag, CHRFB, to generate CPU interrupt requests. Reset clears the CHRIE bit.

- 1 = CHRFB enabled to generate CPU interrupt
- 0 = CHRFB not enabled to generate CPU interrupt

DAYIE — Day Interrupt Enable

This read/write bit enables the day flag, DAYF, to generate CPU interrupt requests. Reset clears the DAYIE bit.

- 1 = DAYF enabled to generate CPU interrupt
- 0 = DAYF not enabled to generate CPU interrupt

HRIE — Hour Interrupt Enable

This read/write bit enables the hour flag, HRF, to generate CPU interrupt requests. Reset clears the HRIE bit.

- 1 = HRF enabled to generate CPU interrupt
- 0 = HRF not enabled to generate CPU interrupt

MINIE — Minute Interrupt Enable

This read/write bit enables the minute flag, MINF, to generate CPU interrupt requests. Reset clears the MINIE bit.

- 1 = MINF enabled to generate CPU interrupt
- 0 = MINF not enabled to generate CPU interrupt

**SECIE — Second Interrupt Enable**

This read/write bit enables the second flag, SECF, to generate CPU interrupt requests. Reset clears the SECIE bit.

- 1 = SECF enabled to generate CPU interrupt
- 0 = SECF not enabled to generate CPU interrupt

**TB1IE — Timebase 1 Interrupt Enable**

This read/write bit enables the timebase1 flag, TB1F, to generate CPU interrupt requests. Reset clears the TB1IE bit.

- 1 = TB1F enabled to generate CPU interrupt
- 0 = TB1F not enabled to generate CPU interrupt

**TB2IE — Timebase 2 Interrupt Enable**

This read/write bit enables the timebase2 flag, TB2F, to generate CPU interrupt requests. Reset clears the TB2IE bit.

- 1 = TB2F enabled to generate CPU interrupt
- 0 = TB2F not enabled to generate CPU interrupt

**12.10.4 RTC Control Register 2 (RTCCR2)**

The RTC control register 2 (RTCCR2) contains control and clock selection bits for RTC operation.

Address: \$0043

Read:	COMEN*	0	CHRE	RTCE*	TBH	0	0	0
Write:	COMEN*	CHRCLR	CHRE	RTCE*	TBH			
Reset:	U	0	0	0 <sup>††</sup>	0	0	0	0

= Unimplemented

<sup>††</sup> Reset by POR only.

\* COMEN and RTCE bits are write-protected; unprotect by a write sequence to RTCWE[1:0] in RTCCOMR.

**Figure 12-9. RTC Control Register 2 (RTCCR2)**

**COMEN — RTC Compensation Enable**

This read/write bit enables the clock compensation mechanism for CGMXCLK frequency errors. Reset has no effect on COMEN bit.

- 1 = Compensation mechanism enabled
- 0 = Compensation mechanism not enabled

**NOTE:** *With compensation enabled, the RTC clock and calendar register updates may not be synchronized to the timebase and chronograph clocks, since their clocks are derived from the uncompensated CGMXCLK.*

Hence, time intervals for timebase ticks may not align with the RTC clock and calendar register updates.

#### CHRCLR — Chronograph counter clear

Setting this write-only bit resets the chronograph counter and the chronograph data register (CHRR). Setting CHRCLR has no effect on any other registers. Counting resumes from \$00. CHRCLR is cleared automatically after the chronograph counter is reset and always reads as logic 0. Reset clears the CHRCLR bit.

- 1 = Chronograph counter cleared
- 0 = No effect

#### CHRE — Chronograph Enable

This read/write bit enables the chronograph counter. When the chronograph counter is disabled (CHRE = 0), the value in the chronograph data register is held at the count value. Reset clears the CHRE bit.

- 1 = Chronograph counter enabled
- 0 = Chronograph counter disabled

#### RTCE — Real Time Clock Enable

This read/write bit enables the entire RTC module, allowing all RTC and chronograph operations. Disabling the RTC module does not affect the contents in the RTC registers. Reset clears the RTCE bit.

- 1 = RTC module enabled
- 0 = RTC module disabled

#### TBH — Timebase High Frequency Select

This read/write bit selects the timebase interrupt period for TB1 and TB2. Reset clears the TBH bit.


- 1 = TB1 interrupt is 0.125s; TB2 interrupt is 0.0625s
- 0 = TB1 interrupt is 0.5s; TB2 interrupt is 0.25s

### 12.10.5 RTC Status Register (RTCSR)

The RTC status register contains eight status flags. When a flag is set and the corresponding interrupt enable bit is also set, a CPU interrupt request is generated.

Address: \$0044

Read:	ALMF	CHRF	DAYF	HRF	MINF	SECF	TB1F	TB2F
Write:								
Reset:	0	0	0	0	0	0	0	0

 = Unimplemented

**Figure 12-10. RTC Status Register (RTCSR)**

#### ALMF — Alarm Flag

This clearable, read-only bit is set when the value in the RTC hour and minute counters matches the value in the alarm hour and alarm minute registers. When the ALMIE bit in RTCCR1 is set, ALMF generates a CPU interrupt request. In normal operation, clear the ALMF bit by reading RTCSR with ALMF set and then reading the alarm hour register (ALHR). Reset clears ALMF.

1 = RTC hour and minute counters matches the alarm hour and minute registers

0 = No matching between hour and minute counters and alarm hour and minute registers

#### CHRF — Chronograph Flag

This clearable, read-only bit is set on every tick of the chronograph counter (every counter count). The tick is on every 1/128 seconds (see [12.5.4 Chronograph Functions](#)). When the CHRIE bit in RTCCR1 is set, CHRF generates a CPU interrupt request. In normal operation, clear the CHRF bit by reading RTCSR with CHRF set and then reading the chronograph data register (CHRR). Reset clears CHRF.

1 = A chronograph counter tick has occurred

0 = No chronograph counter tick has occurred

**DAYF — Day Flag**

This clearable, read-only bit is set on every increment of the day counter. When the DAYIE bit in RTCCR1 is set, DAYF generates a CPU interrupt request. In normal operation, clear the DAYF bit by reading RTCSR with DAYF set and then reading the day register (DAYR). Reset clears DAYF.

- 1 = Day counter incremented
- 0 = No day counter incremented

**HRF — Hour Flag**

This clearable, read-only bit is set on every increment of the hour counter. When the HRIE bit in RTCCR1 is set, HRF generates a CPU interrupt request. In normal operation, clear the HRF bit by reading RTCSR with HRF set and then reading the hour register (HRR). Reset clears HRF.

- 1 = Hour counter incremented
- 0 = No hour counter incremented

**MINF — Minute Flag**

This clearable, read-only bit is set on every increment of the minute counter. When the MINIE bit in RTCCR1 is set, MINF generates a CPU interrupt request. In normal operation, clear the MINF bit by reading RTCSR with MINF set and then reading the minute register (MINR). Reset clears MINF.

- 1 = Minute counter incremented
- 0 = No minute counter incremented

**SECF — Second Flag**

This clearable, read-only bit is set on every increment of the second counter. When the SECIE bit in RTCCR1 is set, SECF generates a CPU interrupt request. In normal operation, clear the SECF bit by reading RTCSR with SECF set and then reading the second register (SECR). Reset clears SECF.

- 1 = Second counter incremented
- 0 = No second counter incremented

**TB1F — Timebase 1 Flag**

This clearable, read-only bit is set on every tick of the timebase 1 counter (every 0.5 or 0.125 seconds). When the TB1IE bit in RTCCR1 is set, TB1F generates a CPU interrupt request. In normal operation, clear the TB1F bit by reading RTCSR with TB1F set and then reading the chronograph data register (CHRR). Reset clears TB1F.

1 = A timebase 1 tick has occurred

0 = No timebase 1 tick has occurred

**NOTE:** *Timebase 1 is not synchronized to the compensated RTC 1-Hz clock. Hence, time intervals for timebase ticks may not align with the RTC clock and calendar register updates.*

**TB2F — Timebase 2 Flag**

This clearable, read-only bit is set on every tick of the timebase 2 counter (every 0.25 or 0.0625 seconds). When the TB2IE bit in RTCCR1 is set, TB2F generates a CPU interrupt request. In normal operation, clear the TB2F bit by reading RTCSR with TB2F set and then reading the chronograph register (CHRR). Reset clears TB2F.

1 = A timebase 2 tick has occurred

0 = No timebase 2 tick has occurred

**NOTE:** *Timebase 2 is not synchronized to the compensated RTC 1-Hz clock. Hence, time intervals for timebase ticks may not align with the RTC clock and calendar register updates.*

Real Time Clock (RTC)

12.10.6 Alarm Minute and Hour Registers (ALMR and ALHR)

These read/write registers contain the alarm minute and hour values for the hour and minute alarm function. When the hour counter matches the value in the alarm hour register (ALHR) and the minute counter matches the value in the alarm minute register (ALMR), the alarm flag, ALMF, is set. When ALMF is set and the alarm interrupt enable bit, ALMIE, is also set, a CPU interrupt request is generated.

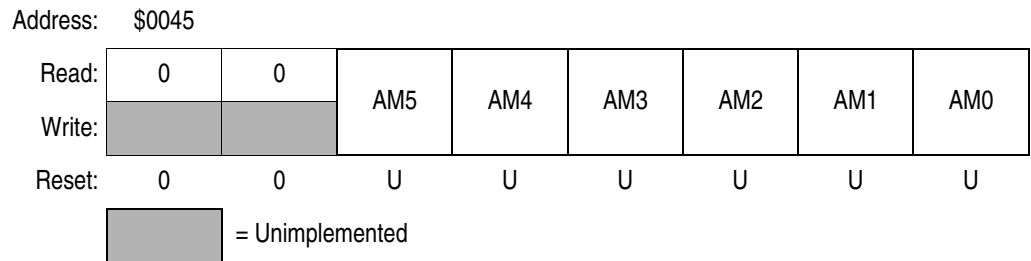


Figure 12-11. Alarm Minute Register (ALMR)

**NOTE:** Writing values other than 0 to 59, to ALMR is possible, but the alarm flag will never be set.

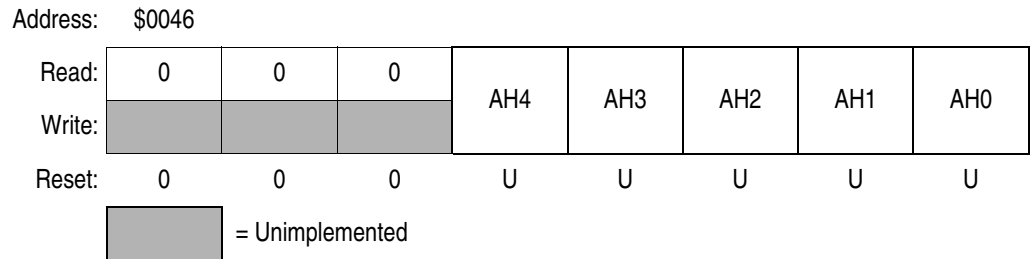


Figure 12-12. Alarm Hour Register (ALHR)

**NOTE:** Writing values other than 0 to 23, to ALHR is possible, but the alarm flag will never be set.

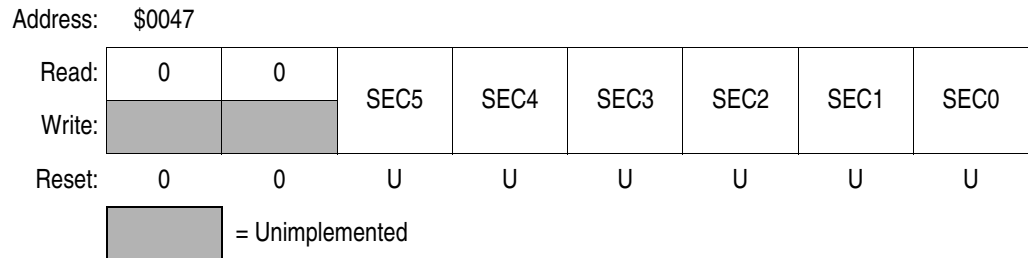
Freescale Semiconductor, Inc.



### 12.10.7 Second Register (SECR)

This read/write register contains the current value of the second counter. This register can be read at any time without affecting the counter count. Writing to this register loads the value to the second counter and the counter continues to count from this new value.

The second counter rolls over to 0 (\$00) after reaching 59 (\$4B). Writing a value other than 0 to 59 to this register has no effect.



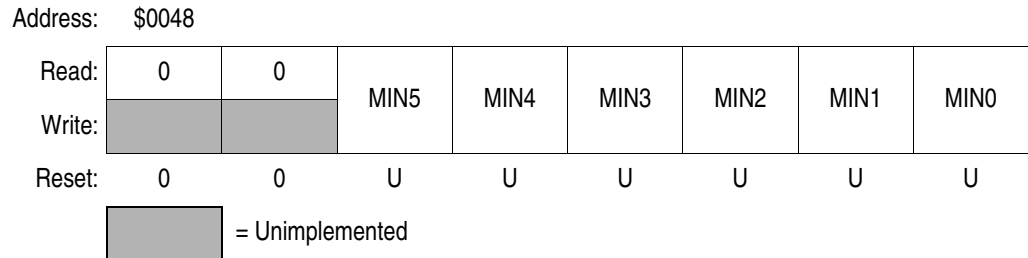
This register is write-protected; unprotect by a write sequence to RTCWE[1:0] in RTCCOMR.

**Figure 12-13. Second Register (SECR)**

### 12.10.8 Minute Register (MINR)

This read/write register contains the current value of the minute counter. This register can be read at any time without affecting the counter count. Writing to this register loads the value to the minute counter and the counter continues to count from this new value.

The minute counter rolls over to 0 (\$00) after reaching 59 (\$4B). Writing a value other than 0 to 59 to this register has no effect.



This register is write-protected; unprotect by a write sequence to RTCWE[1:0] in RTCCOMR.

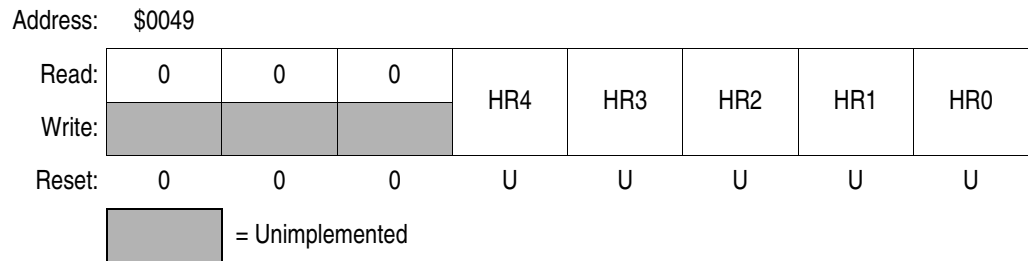
**Figure 12-14. Minute Register (MINR)**

Real Time Clock (RTC)

12.10.9 Hour Register (HRR)

This read/write register contains the current value of the hour counter. This register can be read at any time without affecting the counter count. Writing to this register loads the value to the hour counter and the counter continues to count from this new value.

The hour counter rolls over to 0 (\$00) after reaching 23 (\$17). Writing a value other than 0 to 23 to this register has no effect.



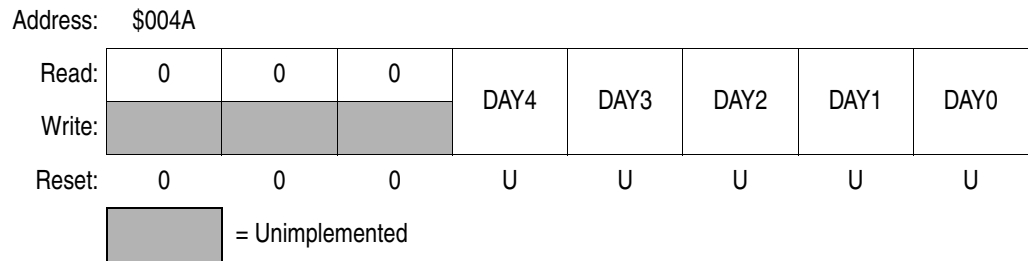
This register is write-protected; unprotect by a write sequence to RTCWE[1:0] in RTCCOMR.

Figure 12-15. Hour Register (HRR)

12.10.10 Day Register (DAYR)

This read/write register contains the current value of the day-of-month counter. This register can be read at any time without affecting the counter count. Writing to this register loads the value to the day counter and the counter continues to count from this new value.

The day counter rolls over to 1 (\$01) after reaching 28 (\$1B), 29 (\$1C), 30 (\$1D), or 31 (\$1E), depending on the value in the month and year registers. Writing a value that is not valid for the month and year to this register has no effect.



This register is write-protected; unprotect by a write sequence to RTCWE[1:0] in RTCCOMR.

Figure 12-16. Day Register (DAYR)


**12.10.11 Month Register (MTHR)**

This read/write register contains the current value of the month counter. This register can be read at any time without affecting the counter count. Writing to this register loads the value to the month counter and the counter continues to count from this new value.

The month counter rolls over to 1 (\$01) after reaching 12 (\$0B). Writing a value other than 1 to 12 to this register has no effect.

Address: \$004B

Read:	0	0	0	0	MTH3	MTH2	MTH1	MTH0
Write:								
Reset:	0	0	0	0	U	U	U	U

 = Unimplemented

This register is write-protected; unprotect by a write sequence to RTCWE[1:0] in RTCCOMR.

**Figure 12-17. Month Register (MTHR)**

**12.10.12 Year Register (YRR)**

This read/write register contains the current value of the year counter. This register can be read at any time without affecting the counter count. Writing to this register loads the value to the year counter and the counter continues to count from this new value.

The value stored in this register is a two's complement representation of the year, relative to 2000. For example, the year 2008 is represented by 8 (\$08), and the year 1979 is presented by -11 (\$F5). The range of this register is only valid for -99 to +99.

Address: \$004C

Read:	YR7	YR6	YR5	YR4	YR3	YR2	YR1	YR0
Write:								
Reset:	U	U	U	U	U	U	U	U

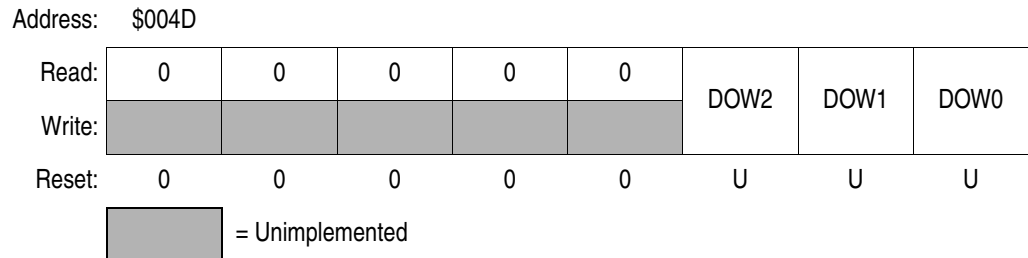
This register is write-protected; unprotect by a write sequence to RTCWE[1:0] in RTCCOMR.

**Figure 12-18. Year Register (YRR)**

12.10.13 Day-Of-Week Register (DOWR)

This read/write register contains the current value of the day-of-week counter. This register can be read at any time without affecting the counter count. Writing to this register loads the value to the day-of-week counter and the counter continues to count from this new value.

The day-of-week counter value rolls over to 0 (\$00) after reaching 6 (\$06). Writing a value other than 0 to 6 to this register has no effect.



This register is write-protected; unprotect by a write sequence to RTCWE[1:0] in RTCCOMR.

Figure 12-19. Day-Of-Week Register (DOWR)

12.10.14 Chronograph Data Register (CHRR)

This read-only chronograph data register contains the value in the chronograph counter. Reset clears the chronograph data register. Setting the chronograph counter reset bit (CHRCLR) also clears the chronograph data register.

The chronograph data register has a resolution of 1/100 seconds. The chronograph counter value rolls over to \$00 after reaching \$63.

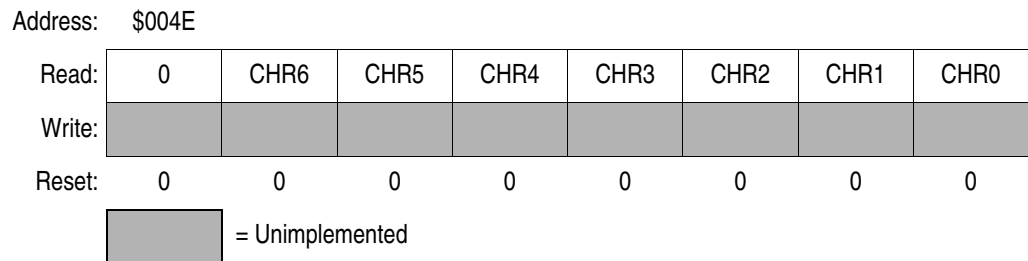


Figure 12-20. Chronograph Data Register (CHRR)

**NOTE:** *The chronograph counter is not synchronized to the compensated RTC 1-Hz clock. Hence, chronograph ticks may not align with the RTC clock and calendar register updates.*

## Section 13. Infrared Serial Communications Interface Module (IRSCI)

### 13.1 Contents

13.2	Introduction . . . . .	246
13.3	Features . . . . .	247
13.4	Pin Name Conventions . . . . .	249
13.5	IRSCI Module Overview . . . . .	249
13.6	Infrared Functional Description . . . . .	250
13.6.1	Infrared Transmit Encoder . . . . .	251
13.6.2	Infrared Receive Decoder . . . . .	251
13.7	SCI Functional Description . . . . .	252
13.7.1	Data Format . . . . .	253
13.7.2	Transmitter . . . . .	254
13.7.2.1	Character Length . . . . .	255
13.7.2.2	Character Transmission . . . . .	255
13.7.2.3	Break Characters . . . . .	256
13.7.2.4	Idle Characters . . . . .	256
13.7.2.5	Transmitter Interrupts . . . . .	257
13.7.3	Receiver . . . . .	257
13.7.3.1	Character Length . . . . .	257
13.7.3.2	Character Reception . . . . .	259
13.7.3.3	Data Sampling . . . . .	259
13.7.3.4	Framing Errors . . . . .	261
13.7.3.5	Baud Rate Tolerance . . . . .	261
13.7.3.6	Receiver Wakeup . . . . .	264
13.7.3.7	Receiver Interrupts . . . . .	265
13.7.3.8	Error Interrupts . . . . .	265
13.8	Low-Power Modes . . . . .	266
13.8.1	Wait Mode . . . . .	266
13.8.2	Stop Mode . . . . .	266

13.9	SCI During Break Module Interrupts . . . . .	267
13.10	I/O Signals . . . . .	267
13.10.1	PTB0/TxD (Transmit Data) . . . . .	267
13.10.2	PTB1/RxD (Receive Data) . . . . .	267
13.11	I/O Registers . . . . .	268
13.11.1	SCI Control Register 1 . . . . .	269
13.11.2	SCI Control Register 2 . . . . .	271
13.11.3	SCI Control Register 3 . . . . .	274
13.11.4	SCI Status Register 1 . . . . .	276
13.11.5	SCI Status Register 2 . . . . .	280
13.11.6	SCI Data Register . . . . .	281
13.11.7	SCI Baud Rate Register . . . . .	282
13.11.8	SCI Infrared Control Register . . . . .	285

## 13.2 Introduction

This section describes the infrared serial communications interface (IRSCI) module which allows high-speed asynchronous communications with peripheral devices and other MCUs. This IRSCI consists of an SCI module for conventional SCI functions and a software programmable infrared encoder/decoder sub-module for encoding/decoding the serial data for connection to infrared LEDs in remote control applications.

**NOTE:** *References to DMA (direct-memory access) and associated functions are only valid if the MCU has a DMA module. This MCU does not have the DMA function. Any DMA-related register bits should be left in their reset state for normal MCU operation.*

### 13.3 Features

Features of the SCI module include the following:

- Full duplex operation
- Standard mark/space non-return-to-zero (NRZ) format
- Programmable 8-bit or 9-bit character length
- Separately enabled transmitter and receiver
- Separate receiver and transmitter CPU interrupt requests
- Two receiver wakeup methods:
  - Idle line wakeup
  - Address mark wakeup
- Interrupt-driven operation with eight interrupt flags:
  - Transmitter empty
  - Transmission complete
  - Receiver full
  - Idle receiver input
  - Receiver overrun
  - Noise error
  - Framing error
  - Parity error
- Receiver framing error detection
- Hardware parity checking
- 1/16 bit-time noise detection

Features of the infrared (IR) sub-module include the following:

- IR sub-module enable/disable for infrared SCI or conventional SCI on TxD and RxD pins
- Software selectable infrared modulation/demodulation (3/16, 1/16 or 1/32 width pulses)

Infrared Serial Communications

Freescale Semiconductor, Inc.

Addr.	Register Name	Bit 7	6	5	4	3	2	1	Bit 0	
\$0013	SCI Control Register 1 (SCC1)	Read:	LOOPS	ENSCI	0	M	WAKE	ILTY	PEN	PTY
		Write:								
		Reset:	0	0	0	0	0	0	0	0
\$0014	SCI Control Register 2 (SCC2)	Read:	SCTIE	TCIE	SCRIE	ILIE	TE	RE	RWU	SBK
		Write:								
		Reset:	0	0	0	0	0	0	0	0
\$0015	SCI Control Register 3 (SCC3)	Read:	R8	T8	DMARE	DMATE	ORIE	NEIE	FEIE	PEIE
		Write:								
		Reset:	U	U	0	0	0	0	0	0
\$0016	SCI Status Register 1 (SCS1)	Read:	SCTE	TC	SCRf	IDLE	OR	NF	FE	PE
		Write:								
		Reset:	1	1	0	0	0	0	0	0
\$0017	SCI Status Register 2 (SCS2)	Read:	0	0	0	0	0	0	BKF	RPF
		Write:								
		Reset:	0	0	0	0	0	0	0	0
\$0018	SCI Data Register (SCDR)	Read:	R7	R6	R5	R4	R3	R2	R1	R0
		Write:	T7	T6	T5	T4	T3	T2	T1	T0
		Reset:	Unaffected by reset							
\$0019	SCI Baud Rate Register (SCBR)	Read:	CKS	0	SCP1	SCP0	R	SCR2	SCR1	SCR0
		Write:								
		Reset:	0	0	0	0	0	0	0	0
\$001A	SCI Infrared Control Register (SCIRCR)	Read:	R	0	0	0	R	TNP1	TNP0	IREN
		Write:								
		Reset:	0	0	0	0	0	0	0	0

= Unimplemented   
 R = Reserved   
 U = Unaffected

**Figure 13-1. IRSCI I/O Registers Summary**



### 13.4 Pin Name Conventions

The generic names of the IRSCI I/O pins are:

- RxD (receive data)
- TxD (transmit data)

IRSCI I/O (input/output) lines are implemented by sharing parallel I/O port pins. The full name of an IRSCI input or output reflects the name of the shared port pin. **Table 13-1** shows the full names and the generic names of the IRSCI I/O pins.

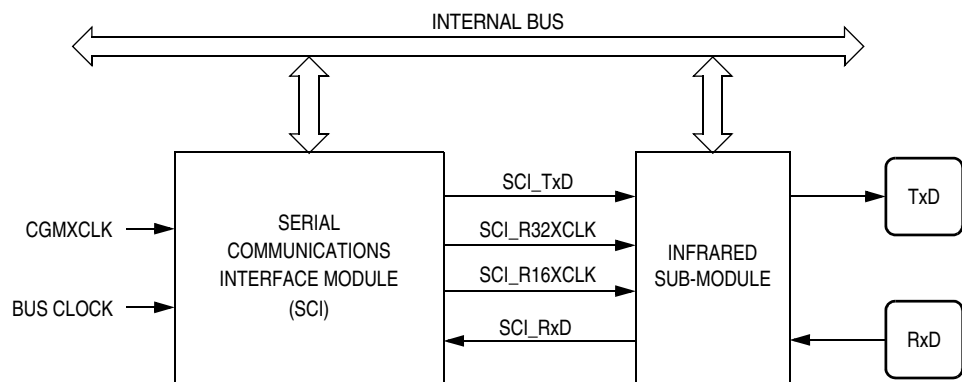
The generic pin names appear in the text of this section.

**Table 13-1. Pin Name Conventions**

<b>Generic Pin Names:</b>	RxD	TxD
<b>Full Pin Names:</b>	PTB1/RxD	PTB0/TxD

### 13.5 IRSCI Module Overview

The IRSCI consists of a serial communications interface (SCI) and a infrared interface sub-module as shown in **Figure 13-2**.



**Figure 13-2. IRSCI Block Diagram**

The SCI module provides serial data transmission and reception, with a programmable baud rate clock based on the bus clock or the CGMXCLK.

The infrared sub-module receives two clock sources from the SCI module: SCI\_R16XCLK and SCI\_R32XCLK. Both reference clocks are used to generate the narrow pulses during data transmission. The SCI\_R16XCLK and SCI\_R32XCLK are internal clocks with frequencies that are 16 and 32 times the baud rate respectively. Both SCI\_R16XCLK and SCI\_R32XCLK clocks are used for transmitting data. The SCI\_R16XCLK clock is used only for receiving data.

**NOTE:** For proper SCI function (transmit or receive), the bus clock **MUST** be programmed to at least 32 times that of the selected baud rate. When the infrared sub-module is disabled, signals on the TxD and RxD pins pass through unchanged to the SCI module.

### 13.6 Infrared Functional Description

Figure 13-3 shows the structure of the infrared sub-module.

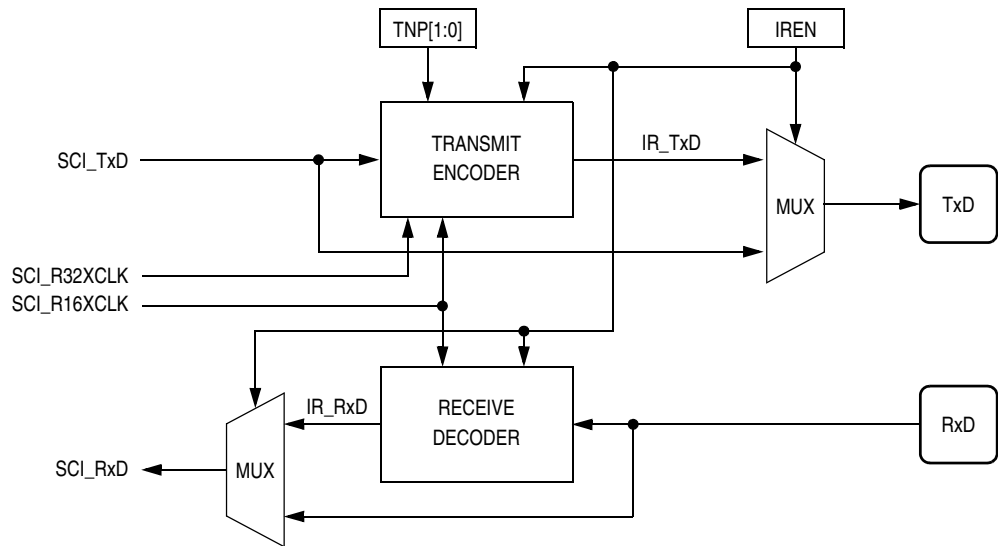


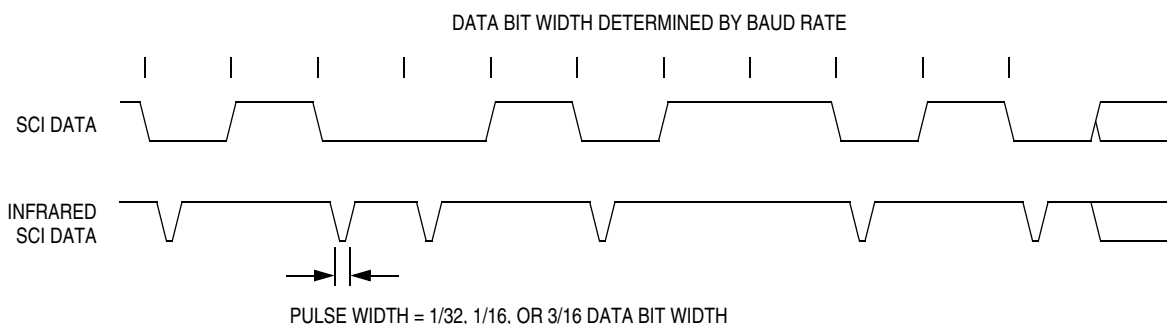
Figure 13-3. Infrared Sub-Module Diagram

The infrared sub-module provides the capability of transmitting narrow pulses to an infrared LED and receiving narrow pulses and transforming them to serial bits, which are sent to the SCI module. The infrared sub-module receives two clocks from the SCI. One of these two clocks is selected as the base clock to generate the 3/16, 1/16, or 1/32 bit width narrow pulses during transmission.

The sub-module consists of two main blocks: the transmit encoder and the receive decoder. When transmitting data, the SCI data stream is encoded by the infrared sub-module. For every "0" bit, a narrow "low" pulse is transmitted; no pulse is transmitted for "1" bits. When receiving data, the infrared pulses should be detected using an infrared photo diode for conversion to CMOS voltage levels before connecting to the RxD pin for the infrared decoder. The SCI data stream is reconstructed by stretching the "0" pulses.

## 13.6.1 Infrared Transmit Encoder

The infrared transmit encoder converts the "0" bits in the serial data stream from the SCI module to narrow "low" pulses, to the TxD pin. The narrow pulse is sent with a duration of  $1/32$ ,  $1/16$ , or  $3/16$  of a data bit width. When two consecutive zeros are sent, the two consecutive narrow pulses will be separated by a time equal to a data bit width.



**Figure 13-4. Infrared SCI Data Example**

## 13.6.2 Infrared Receive Decoder

The infrared receive decoder converts low narrow pulses from the RxD pin to standard SCI data bits. The reference clock, SCI\_R16XCLK, clocks a four bit internal counter which counts from 0 to 15. An incoming pulse starts the internal counter and a "0" is sent out to the IR\_RxD output. Subsequent incoming pulses are ignored when the counter count is between 0 and 7; IR\_RxD remains "0". Once the counter passes 7, an incoming pulse will reset the counter; IR\_RxD remains "0". When the counter reaches 15, the IR\_RxD output returns to "1", the counter stops and waits for further pulses. A pulse is interpreted as jitter if it arrives shortly after the counter reaches 15; IR\_RxD remains "1".

13.7 SCI Functional Description

Figure 13-5 shows the structure of the SCI.

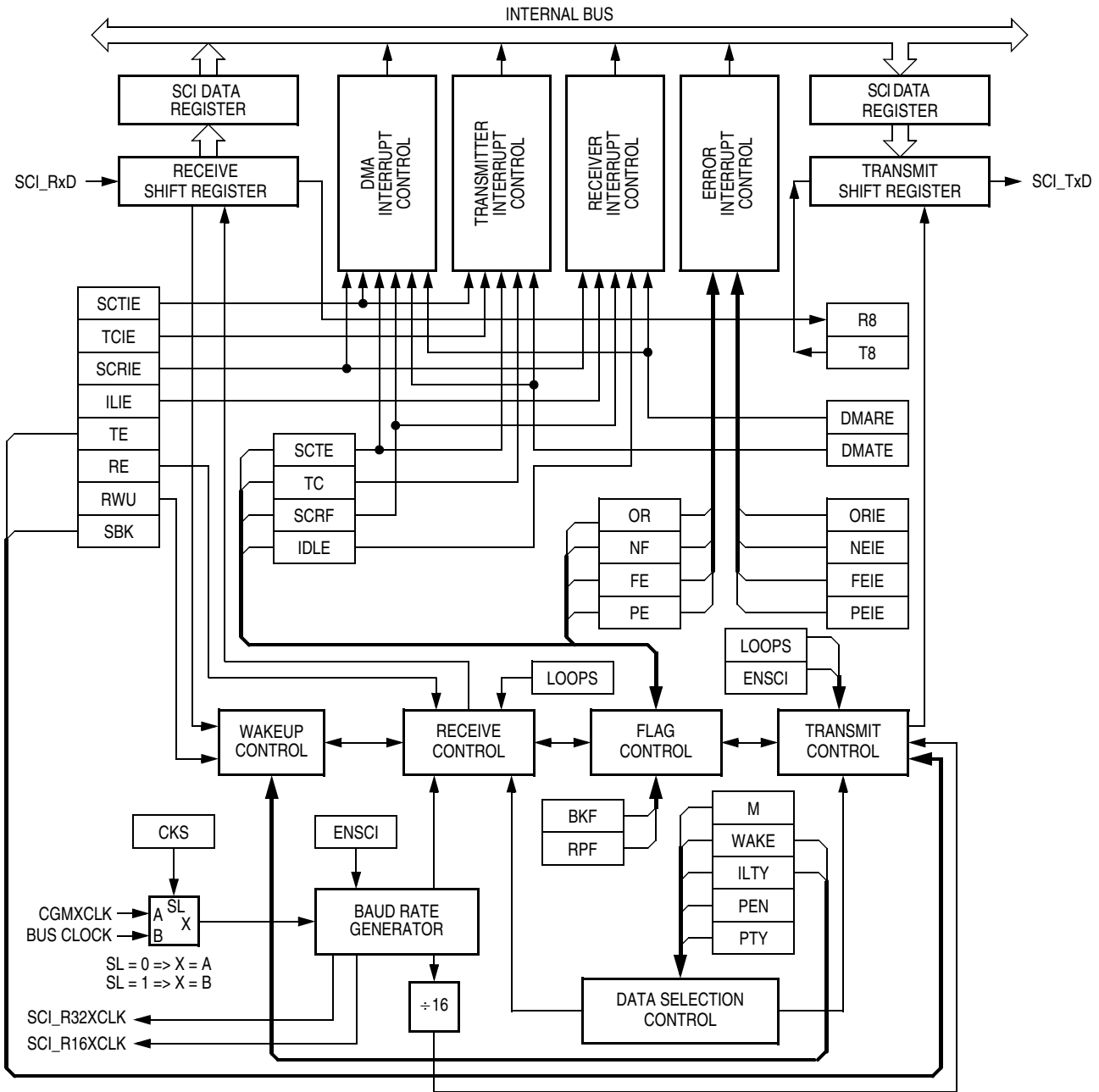


Figure 13-5. SCI Module Block Diagram

The SCI allows full-duplex, asynchronous, NRZ serial communication between the MCU and remote devices, including other MCUs. The transmitter and receiver of the SCI operate independently, although they use the same baud rate generator. During normal operation, the CPU monitors the status of the SCI, writes the data to be transmitted, and processes received data.

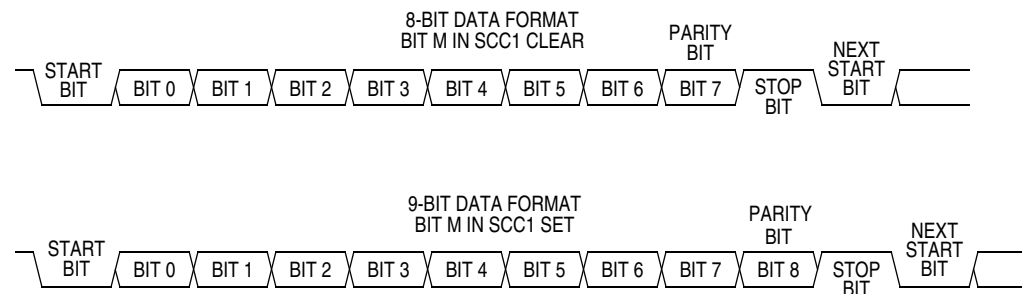
**NOTE:** For SCI operations, the IR sub-module is transparent to the SCI module. Data at going out of the SCI transmitter and data going into the SCI receiver is always in SCI format. It makes no difference to the SCI module whether the IR sub-module is enabled or disabled.

**NOTE:** This SCI module is a standard HC08 SCI module with the following modifications:

- A control bit, *CKS*, is added to the SCI baud rate control register to select between two input clocks for baud rate clock generation
- The *TXINV* bit is removed from the SCI control register 1

### 13.7.1 Data Format

The SCI uses the standard non-return-to-zero mark/space data format illustrated in [Figure 13-6](#).



**Figure 13-6. SCI Data Formats**

13.7.2 Transmitter

Figure 13-7 shows the structure of the SCI transmitter.

The baud rate clock source for the SCI can be selected by the CKS bit, in the SCI baud rate register (see 13.11.7 SCI Baud Rate Register).

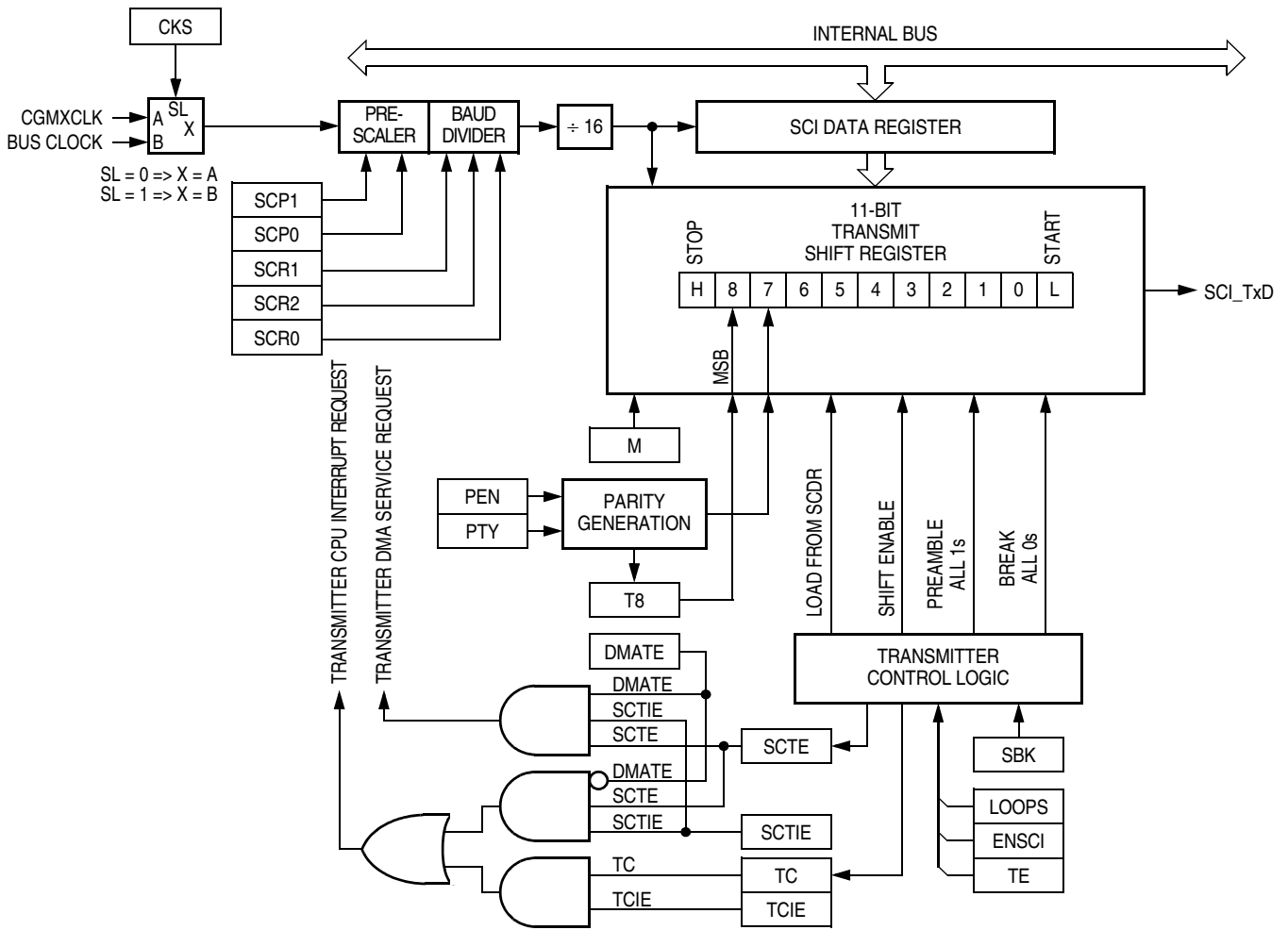


Figure 13-7. SCI Transmitter

## 13.7.2.1 Character Length

The transmitter can accommodate either 8-bit or 9-bit data. The state of the M bit in SCI control register 1 (SCC1) determines character length. When transmitting 9-bit data, bit T8 in SCI control register 3 (SCC3) is the ninth bit (bit 8).

## 13.7.2.2 Character Transmission

During an SCI transmission, the transmit shift register shifts a character out to the TxD pin. The SCI data register (SCDR) is the write-only buffer between the internal data bus and the transmit shift register. To initiate an SCI transmission:

1. Enable the SCI by writing a logic 1 to the enable SCI bit (ENSCI) in SCI control register 1 (SCC1).
2. Enable the transmitter by writing a logic 1 to the transmitter enable bit (TE) in SCI control register 2 (SCC2).
3. Clear the SCI transmitter empty bit by first reading SCI status register 1 (SCS1) and then writing to the SCDR.
4. Repeat step 3 for each subsequent transmission.

At the start of a transmission, transmitter control logic automatically loads the transmit shift register with a preamble of logic 1s. After the preamble shifts out, control logic transfers the SCDR data into the transmit shift register. A logic 0 start bit automatically goes into the least significant bit position of the transmit shift register. A logic 1 stop bit goes into the most significant bit position.

The SCI transmitter empty bit, SCTE, in SCS1 becomes set when the SCDR transfers a byte to the transmit shift register. The SCTE bit indicates that the SCDR can accept new data from the internal data bus. If the SCI transmit interrupt enable bit, SCTIE, in SCC2 is also set, the SCTE bit generates a transmitter interrupt request.

When the transmit shift register is not transmitting a character, the TxD pin goes to the idle condition, logic 1. If at any time software clears the ENSCI bit in SCI control register 1 (SCC1), the transmitter and receiver relinquish control of the port pins.

### 13.7.2.3 Break Characters

Writing a logic 1 to the send break bit, SBK, in SCC2 loads the transmit shift register with a break character. A break character contains all logic 0s and has no start, stop, or parity bit. Break character length depends on the M bit in SCC1. As long as SBK is at logic 1, transmitter logic continuously loads break characters into the transmit shift register. After software clears the SBK bit, the shift register finishes transmitting the last break character and then transmits at least one logic 1. The automatic logic 1 at the end of a break character guarantees the recognition of the start bit of the next character.

The SCI recognizes a break character when a start bit is followed by eight or nine logic 0 data bits and a logic 0 where the stop bit should be.

Receiving a break character has the following effects on SCI registers:

- Sets the framing error bit (FE) in SCS1
- Sets the SCI receiver full bit (SCRF) in SCS1
- Clears the SCI data register (SCDR)
- Clears the R8 bit in SCC3
- Sets the break flag bit (BKF) in SCS2
- May set the overrun (OR), noise flag (NF), parity error (PE), or reception in progress flag (RPF) bits

### 13.7.2.4 Idle Characters

An idle character contains all logic 1s and has no start, stop, or parity bit. Idle character length depends on the M bit in SCC1. The preamble is a synchronizing idle character that begins every transmission.

If the TE bit is cleared during a transmission, the TxD pin becomes idle after completion of the transmission in progress. Clearing and then setting the TE bit during a transmission queues an idle character to be sent after the character currently being transmitted.



**NOTE:** *When queueing an idle character, return the TE bit to logic 1 before the stop bit of the current character shifts out to the TxD pin. Setting TE after the stop bit appears on TxD causes data previously written to the SCDR to be lost.*

*Toggle the TE bit for a queued idle character when the SCTE bit becomes set and just before writing the next byte to the SCDR.*

### 13.7.2.5 Transmitter Interrupts

The following conditions can generate CPU interrupt requests from the SCI transmitter:

- SCI transmitter empty (SCTE) — The SCTE bit in SCS1 indicates that the SCDR has transferred a character to the transmit shift register. SCTE can generate a transmitter CPU interrupt request. Setting the SCI transmit interrupt enable bit, SCTIE, in SCC2 enables the SCTE bit to generate transmitter CPU interrupt requests.
- Transmission complete (TC) — The TC bit in SCS1 indicates that the transmit shift register and the SCDR are empty and that no break or idle character has been generated. The transmission complete interrupt enable bit, TCIE, in SCC2 enables the TC bit to generate transmitter CPU interrupt requests.

## 13.7.3 Receiver

**Figure 13-8** shows the structure of the SCI receiver.

### 13.7.3.1 Character Length

The receiver can accommodate either 8-bit or 9-bit data. The state of the M bit in SCI control register 1 (SCC1) determines character length. When receiving 9-bit data, bit R8 in SCI control register 2 (SCC2) is the ninth bit (bit 8). When receiving 8-bit data, bit R8 is a copy of the eighth bit (bit 7).

Infrared Serial Communications

Freescale Semiconductor, Inc.

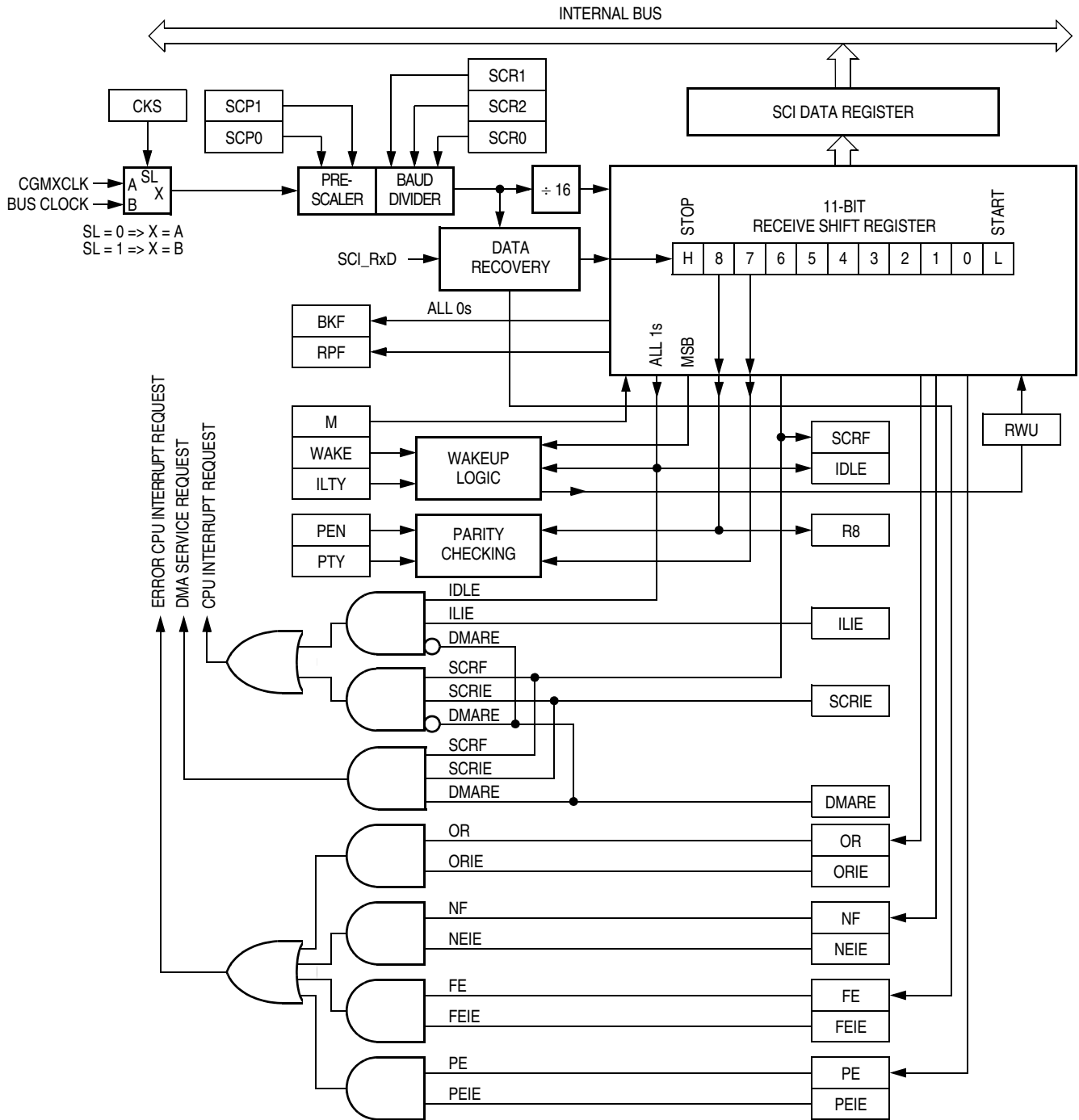


Figure 13-8. SCI Receiver Block Diagram

13.7.3.2 Character Reception

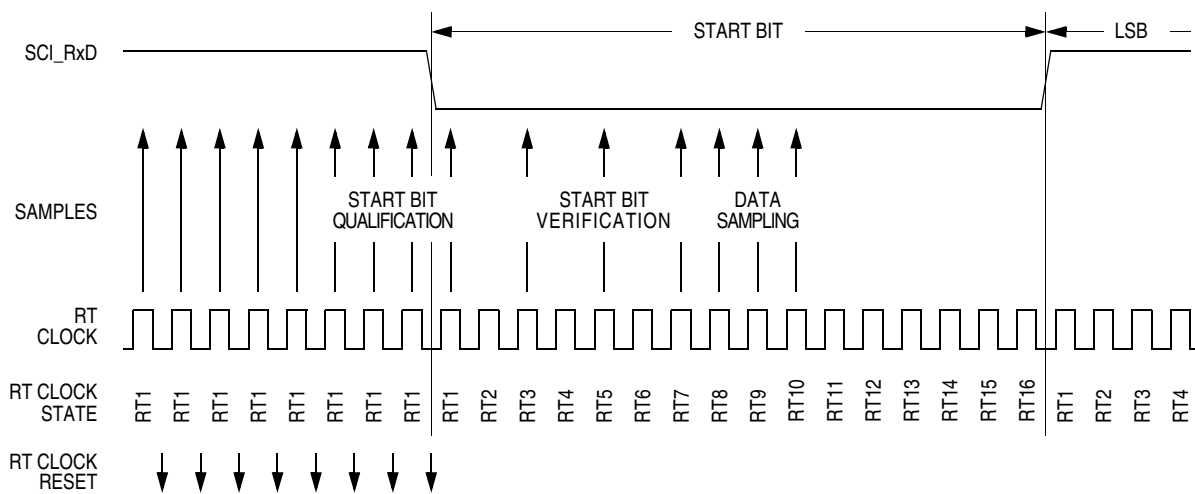
During an SCI reception, the receive shift register shifts characters in from the RxD pin. The SCI data register (SCDR) is the read-only buffer between the internal data bus and the receive shift register.

After a complete character shifts into the receive shift register, the data portion of the character transfers to the SCDR. The SCI receiver full bit, SCRF, in SCI status register 1 (SCS1) becomes set, indicating that the received byte can be read. If the SCI receive interrupt enable bit, SCRIE, in SCC2 is also set, the SCRF bit generates a receiver CPU interrupt request.

13.7.3.3 Data Sampling

The receiver samples the RxD pin at the RT clock rate. The RT clock is an internal signal with a frequency 16 times the baud rate. To adjust for baud rate mismatch, the RT clock is resynchronized at the following times (see **Figure 13-9**):

- After every start bit
- After the receiver detects a data bit change from logic 1 to logic 0 (after the majority of data bit samples at RT8, RT9, and RT10 returns a valid logic 1 and the majority of the next RT8, RT9, and RT10 samples returns a valid logic 0)



**Figure 13-9. Receiver Data Sampling**

To locate the start bit, data recovery logic does an asynchronous search for a logic 0 preceded by three logic 1s. When the falling edge of a possible start bit occurs, the RT clock begins to count to 16.

To verify the start bit and to detect noise, data recovery logic takes samples at RT3, RT5, and RT7. **Table 13-2** summarizes the results of the start bit verification samples.

**Table 13-2. Start Bit Verification**

RT3, RT5, and RT7 Samples	Start Bit Verification	Noise Flag
000	Yes	0
001	Yes	1
010	Yes	1
011	No	0
100	Yes	1
101	No	0
110	No	0
111	No	0

If start bit verification is not successful, the RT clock is reset and a new search for a start bit begins.

To determine the value of a data bit and to detect noise, recovery logic takes samples at RT8, RT9, and RT10. **Table 13-3** summarizes the results of the data bit samples.

**Table 13-3. Data Bit Recovery**

RT8, RT9, and RT10 Samples	Data Bit Determination	Noise Flag
000	0	0
001	0	1
010	0	1
011	1	1
100	0	1
101	1	1
110	1	1
111	1	0

**NOTE:** *The RT8, RT9, and RT10 samples do not affect start bit verification. If any or all of the RT8, RT9, and RT10 start bit samples are logic 1s following a successful start bit verification, the noise flag (NF) is set and the receiver assumes that the bit is a start bit.*

To verify a stop bit and to detect noise, recovery logic takes samples at RT8, RT9, and RT10. **Table 13-4** summarizes the results of the stop bit samples.

**Table 13-4. Stop Bit Recovery**

RT8, RT9, and RT10 Samples	Framing Error Flag	Noise Flag
000	1	0
001	1	1
010	1	1
011	0	1
100	1	1
101	0	1
110	0	1
111	0	0

### 13.7.3.4 Framing Errors

If the data recovery logic does not detect a logic 1 where the stop bit should be in an incoming character, it sets the framing error bit, FE, in SCS1. The FE flag is set at the same time that the SCRF bit is set. A break character that has no stop bit also sets the FE bit.

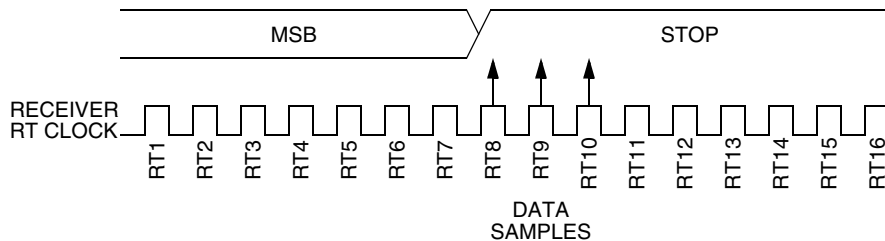
### 13.7.3.5 Baud Rate Tolerance

A transmitting device may be operating at a baud rate below or above the receiver baud rate. Accumulated bit time misalignment can cause one of the three stop bit data samples to fall outside the actual stop bit. Then a noise error occurs. If more than one of the samples is outside the stop bit, a framing error occurs. In most applications, the baud rate tolerance is much more than the degree of misalignment that is likely to occur.

As the receiver samples an incoming character, it resynchronizes the RT clock on any valid falling edge within the character. Resynchronization within characters corrects misalignments between transmitter bit times and receiver bit times.

**Slow Data Tolerance**

**Figure 13-10** shows how much a slow received character can be misaligned without causing a noise error or a framing error. The slow stop bit begins at RT8 instead of RT1 but arrives in time for the stop bit data samples at RT8, RT9, and RT10.



**Figure 13-10. Slow Data**

For an 8-bit character, data sampling of the stop bit takes the receiver 9 bit times × 16 RT cycles + 10 RT cycles = 154 RT cycles.

With the misaligned character shown in **Figure 13-10**, the receiver counts 154 RT cycles at the point when the count of the transmitting device is 9 bit times × 16 RT cycles + 3 RT cycles = 147 RT cycles.

The maximum percent difference between the receiver count and the transmitter count of a slow 8-bit character with no errors is

$$\left| \frac{154 - 147}{154} \right| \times 100 = 4.54\%$$

For a 9-bit character, data sampling of the stop bit takes the receiver 10 bit times × 16 RT cycles + 10 RT cycles = 170 RT cycles.

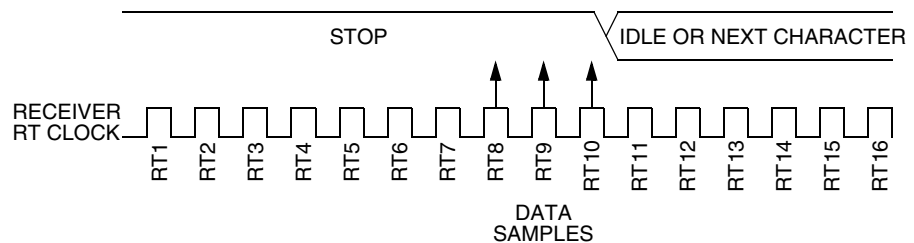
With the misaligned character shown in **Figure 13-10**, the receiver counts 170 RT cycles at the point when the count of the transmitting device is 10 bit times × 16 RT cycles + 3 RT cycles = 163 RT cycles.

The maximum percent difference between the receiver count and the transmitter count of a slow 9-bit character with no errors is

$$\left| \frac{170 - 163}{170} \right| \times 100 = 4.12\%$$

**Fast Data Tolerance**

**Figure 13-11** shows how much a fast received character can be misaligned without causing a noise error or a framing error. The fast stop bit ends at RT10 instead of RT16 but is still there for the stop bit data samples at RT8, RT9, and RT10.



**Figure 13-11. Fast Data**

For an 8-bit character, data sampling of the stop bit takes the receiver 9 bit times × 16 RT cycles + 10 RT cycles = 154 RT cycles.

With the misaligned character shown in **Figure 13-11**, the receiver counts 154 RT cycles at the point when the count of the transmitting device is 10 bit times × 16 RT cycles = 160 RT cycles.

The maximum percent difference between the receiver count and the transmitter count of a fast 8-bit character with no errors is

$$\left| \frac{154 - 160}{154} \right| \times 100 = 3.90\%$$

For a 9-bit character, data sampling of the stop bit takes the receiver 10 bit times × 16 RT cycles + 10 RT cycles = 170 RT cycles.

With the misaligned character shown in **Figure 13-11**, the receiver counts 170 RT cycles at the point when the count of the transmitting device is 11 bit times × 16 RT cycles = 176 RT cycles.

The maximum percent difference between the receiver count and the transmitter count of a fast 9-bit character with no errors is

$$\left| \frac{170 - 176}{170} \right| \times 100 = 3.53\%$$

### 13.7.3.6 Receiver Wakeup

So that the MCU can ignore transmissions intended only for other receivers in multiple-receiver systems, the receiver can be put into a standby state. Setting the receiver wakeup bit, RWU, in SCC2 puts the receiver into a standby state during which receiver interrupts are disabled.

Depending on the state of the WAKE bit in SCC1, either of two conditions on the RxD pin can bring the receiver out of the standby state:

- Address mark — An address mark is a logic 1 in the most significant bit position of a received character. When the WAKE bit is set, an address mark wakes the receiver from the standby state by clearing the RWU bit. The address mark also sets the SCI receiver full bit, SCRF. Software can then compare the character containing the address mark to the user-defined address of the receiver. If they are the same, the receiver remains awake and processes the characters that follow. If they are not the same, software can set the RWU bit and put the receiver back into the standby state.
- Idle input line condition — When the WAKE bit is clear, an idle character on the RxD pin wakes the receiver from the standby state by clearing the RWU bit. The idle character that wakes the receiver does not set the receiver idle bit, IDLE, or the SCI receiver full bit, SCRF. The idle line type bit, ILTY, determines whether the receiver begins counting logic 1s as idle character bits after the start bit or after the stop bit.

**NOTE:** *Clearing the WAKE bit after the RxD pin has been idle may cause the receiver to wake up immediately.*



### 13.7.3.7 Receiver Interrupts

The following sources can generate CPU interrupt requests from the SCI receiver:

- SCI receiver full (SCRF) — The SCRF bit in SCS1 indicates that the receive shift register has transferred a character to the SCDR. SCRF can generate a receiver interrupt request. Setting the SCI receive interrupt enable bit, SCRIE, in SCC2 enables the SCRF bit to generate receiver CPU interrupts.
- Idle input (IDLE) — The IDLE bit in SCS1 indicates that 10 or 11 consecutive logic 1s shifted in from the RxD pin. The idle line interrupt enable bit, ILIE, in SCC2 enables the IDLE bit to generate CPU interrupt requests.

### 13.7.3.8 Error Interrupts

The following receiver error flags in SCS1 can generate CPU interrupt requests:

- Receiver overrun (OR) — The OR bit indicates that the receive shift register shifted in a new character before the previous character was read from the SCDR. The previous character remains in the SCDR, and the new character is lost. The overrun interrupt enable bit, ORIE, in SCC3 enables OR to generate SCI error CPU interrupt requests.
- Noise flag (NF) — The NF bit is set when the SCI detects noise on incoming data or break characters, including start, data, and stop bits. The noise error interrupt enable bit, NEIE, in SCC3 enables NF to generate SCI error CPU interrupt requests.
- Framing error (FE) — The FE bit in SCS1 is set when a logic 0 occurs where the receiver expects a stop bit. The framing error interrupt enable bit, FEIE, in SCC3 enables FE to generate SCI error CPU interrupt requests.
- Parity error (PE) — The PE bit in SCS1 is set when the SCI detects a parity error in incoming data. The parity error interrupt enable bit, PEIE, in SCC3 enables PE to generate SCI error CPU interrupt requests.

## 13.8 Low-Power Modes

The WAIT and STOP instructions put the MCU in low power-consumption standby modes.

### 13.8.1 Wait Mode

The SCI module remains active after the execution of a WAIT instruction. In wait mode, the SCI module registers are not accessible by the CPU. Any enabled CPU interrupt request from the SCI module can bring the MCU out of wait mode.

If SCI module functions are not required during wait mode, reduce power consumption by disabling the module before executing the WAIT instruction.

Refer to [9.7 Low-Power Modes](#) for information on exiting wait mode.

### 13.8.2 Stop Mode

The SCI module is inactive after the execution of a STOP instruction. The STOP instruction does not affect SCI register states. SCI module operation resumes after an external interrupt.

Because the internal clock is inactive during stop mode, entering stop mode during an SCI transmission or reception results in invalid data.

Refer to [9.7 Low-Power Modes](#) for information on exiting stop mode.

## 13.9 SCI During Break Module Interrupts

The system integration module (SIM) controls whether status bits in other modules can be cleared during interrupts generated by the break module. The BCFE bit in the SIM break flag control register (SBFCR) enables software to clear status bits during the break state.

To allow software to clear status bits during a break interrupt, write a logic 1 to the BCFE bit. If a status bit is cleared during the break state, it remains cleared when the MCU exits the break state.

To protect status bits during the break state, write a logic 0 to the BCFE bit. With BCFE at logic 0 (its default state), software can read and write I/O registers during the break state without affecting status bits. Some status bits have a two-step read/write clearing procedure. If software does the first step on such a bit before the break, the bit cannot change during the break state as long as BCFE is at logic 0. After the break, doing the second step clears the status bit.

### 13.10 I/O Signals

The two IRSCI I/O pins are:

- PTB0/TxD — Transmit data
- PTB1/RxD — Receive data

#### 13.10.1 PTB0/TxD (Transmit Data)

The PTB0/TxD pin is the serial data (standard or infrared) output from the SCI transmitter. The IRSCI shares the PTB0/TxD pin with port B. When the IRSCI is enabled, the PTB0/TxD pin is an output regardless of the state of the DDRB0 bit in data direction register B (DDRB). TxD pin has high current (15mA) sink capability when the LEDB0 bit is set in the port B LED control register (\$000C).

#### 13.10.2 PTB1/RxD (Receive Data)

The PTB1/RxD pin is the serial data input to the IRSCI receiver. The IRSCI shares the PTB1/RxD pin with port B. When the IRSCI is enabled, the PTB1/RxD pin is an input regardless of the state of the DDRB1 bit in data direction register B (DDRB).

Table 13-5 shows a summary of I/O pin functions when the SCI is enabled.

Table 13-5. SCI Pin Functions (Standard and Infrared)

SCC1 [ENSCI]	SCIRCR [IREN]	SCC2 [TE]	SCC2 [RE]	TxD Pin	RxD Pin
1	0	0	0	Hi-Z <sup>(1)</sup>	Input ignored (terminate externally)
1	0	0	1	Hi-Z <sup>(1)</sup>	Input sampled, pin should idle high
1	0	1	0	Output SCI (idle high)	Input ignored (terminate externally)
1	0	1	1	Output SCI (idle high)	Input sampled, pin should idle high
1	1	0	0	Hi-Z <sup>(1)</sup>	Input ignored (terminate externally)
1	1	0	1	Hi-Z <sup>(1)</sup>	Input sampled, pin should idle high
1	1	1	0	Output IR SCI (idle high)	Input ignored (terminate externally)
1	1	1	1	Output IR SCI (idle high)	Input sampled, pin should idle high
0	X	X	X	Pins under port control (standard I/O port)	

**Notes:**

1. After completion of transmission in progress.

### 13.11 I/O Registers

The following I/O registers control and monitor SCI operation:

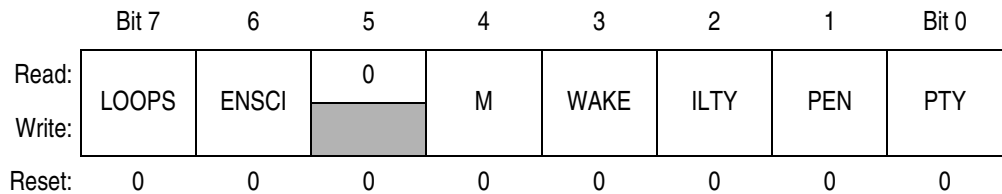
- SCI control register 1 (SCC1)
- SCI control register 2 (SCC2)
- SCI control register 3 (SCC3)
- SCI status register 1 (SCS1)
- SCI status register 2 (SCS2)
- SCI data register (SCDR)
- SCI baud rate register (SCBR)
- SCI infrared control register (SCIRCR)

**13.11.1 SCI Control Register 1**

SCI control register 1:

- Enables loop mode operation
- Enables the SCI
- Controls output polarity
- Controls character length
- Controls SCI wakeup method
- Controls idle character detection
- Enables parity function
- Controls parity type

Address: \$0013



**Figure 13-12. SCI Control Register 1 (SCC1)**

**LOOPS — Loop Mode Select Bit**

This read/write bit enables loop mode operation for the SCI only. In loop mode the RxD pin is disconnected from the SCI, and the transmitter output goes into the receiver input. Both the transmitter and the receiver must be enabled to use loop mode. The infrared encoder/decoder is not in the loop. Reset clears the LOOPS bit.

- 1 = Loop mode enabled
- 0 = Normal operation enabled

**ENSCI — Enable SCI Bit**

This read/write bit enables the SCI and the SCI baud rate generator. Clearing ENSCI sets the SCTE and TC bits in SCI status register 1 and disables transmitter interrupts. Reset clears the ENSCI bit.

- 1 = SCI enabled
- 0 = SCI disabled

**M** — Mode (Character Length) Bit

This read/write bit determines whether SCI characters are eight or nine bits long. (See [Table 13-6](#).) The ninth bit can serve as an extra stop bit, as a receiver wakeup signal, or as a parity bit. Reset clears the M bit.

- 1 = 9-bit SCI characters
- 0 = 8-bit SCI characters

**WAKE** — Wakeup Condition Bit

This read/write bit determines which condition wakes up the SCI: a logic 1 (address mark) in the most significant bit position of a received character or an idle condition on the RxD pin. Reset clears the WAKE bit.

- 1 = Address mark wakeup
- 0 = Idle line wakeup

**ILTY** — Idle Line Type Bit

This read/write bit determines when the SCI starts counting logic 1s as idle character bits. The counting begins either after the start bit or after the stop bit. If the count begins after the start bit, then a string of logic 1s preceding the stop bit may cause false recognition of an idle character. Beginning the count after the stop bit avoids false idle character recognition, but requires properly synchronized transmissions. Reset clears the ILTY bit.

- 1 = Idle character bit count begins after stop bit
- 0 = Idle character bit count begins after start bit

**PEN** — Parity Enable Bit

This read/write bit enables the SCI parity function. (See [Table 13-6](#).) When enabled, the parity function inserts a parity bit in the most significant bit position. (See [Figure 13-6](#).) Reset clears the PEN bit.

- 1 = Parity function enabled
- 0 = Parity function disabled

**PTY — Parity Bit**

This read/write bit determines whether the SCI generates and checks for odd parity or even parity. (See [Table 13-6.](#)) Reset clears the PTY bit.

- 1 = Odd parity
- 0 = Even parity

**NOTE:** *Changing the PTY bit in the middle of a transmission or reception can generate a parity error.*

**Table 13-6. Character Format Selection**

Control Bits		Character Format				
M	PEN:PTY	Start Bits	Data Bits	Parity	Stop Bits	Character Length
0	0X	1	8	None	1	10 bits
1	0X	1	9	None	1	11 bits
0	10	1	7	Even	1	10 bits
0	11	1	7	Odd	1	10 bits
1	10	1	8	Even	1	11 bits
1	11	1	8	Odd	1	11 bits

**13.11.2 SCI Control Register 2**

SCI control register 2:

- Enables the following CPU interrupt requests:
  - Enables the SCTE bit to generate transmitter CPU interrupt requests
  - Enables the TC bit to generate transmitter CPU interrupt requests
  - Enables the SCRF bit to generate receiver CPU interrupt requests
  - Enables the IDLE bit to generate receiver CPU interrupt requests
- Enables the transmitter
- Enables the receiver
- Enables SCI wakeup
- Transmits SCI break characters

Address: \$0014

	Bit 7	6	5	4	3	2	1	Bit 0
Read:	SCTIE	TCIE	SCRIE	ILIE	TE	RE	RWU	SBK
Write:								
Reset:	0	0	0	0	0	0	0	0

**Figure 13-13. SCI Control Register 2 (SCC2)**

**SCTIE — SCI Transmit Interrupt Enable Bit**

This read/write bit enables the SCTE bit to generate SCI transmitter CPU interrupt requests. Reset clears the SCTIE bit.

- 1 = SCTE enabled to generate CPU interrupt
- 0 = SCTE not enabled to generate CPU interrupt

**TCIE — Transmission Complete Interrupt Enable Bit**

This read/write bit enables the TC bit to generate SCI transmitter CPU interrupt requests. Reset clears the TCIE bit.

- 1 = TC enabled to generate CPU interrupt requests
- 0 = TC not enabled to generate CPU interrupt requests

**SCRIE — SCI Receive Interrupt Enable Bit**

This read/write bit enables the SCRF bit to generate SCI receiver CPU interrupt requests. Reset clears the SCRIE bit.

- 1 = SCRF enabled to generate CPU interrupt
- 0 = SCRF not enabled to generate CPU interrupt

**ILIE — Idle Line Interrupt Enable Bit**

This read/write bit enables the IDLE bit to generate SCI receiver CPU interrupt requests. Reset clears the ILIE bit.

- 1 = IDLE enabled to generate CPU interrupt requests
- 0 = IDLE not enabled to generate CPU interrupt requests

**TE — Transmitter Enable Bit**

Setting this read/write bit begins the transmission by sending a preamble of 10 or 11 logic 1s from the transmit shift register to the TxD pin. If software clears the TE bit, the transmitter completes any transmission in progress before the TxD returns to the idle condition



(logic 1). Clearing and then setting TE during a transmission queues an idle character to be sent after the character currently being transmitted. Reset clears the TE bit.

- 1 = Transmitter enabled
- 0 = Transmitter disabled

**NOTE:** *Writing to the TE bit is not allowed when the enable SCI bit (ENSCI) is clear. ENSCI is in SCI control register 1.*

#### RE — Receiver Enable Bit

Setting this read/write bit enables the receiver. Clearing the RE bit disables the receiver but does not affect receiver interrupt flag bits. Reset clears the RE bit.

- 1 = Receiver enabled
- 0 = Receiver disabled

**NOTE:** *Writing to the RE bit is not allowed when the enable SCI bit (ENSCI) is clear. ENSCI is in SCI control register 1.*

#### RWU — Receiver Wakeup Bit

This read/write bit puts the receiver in a standby state during which receiver interrupts are disabled. The WAKE bit in SCC1 determines whether an idle input or an address mark brings the receiver out of the standby state and clears the RWU bit. Reset clears the RWU bit.

- 1 = Standby state
- 0 = Normal operation

#### SBK — Send Break Bit

Setting and then clearing this read/write bit transmits a break character followed by a logic 1. The logic 1 after the break character guarantees recognition of a valid start bit. If SBK remains set, the transmitter continuously transmits break characters with no logic 1s between them. Reset clears the SBK bit.

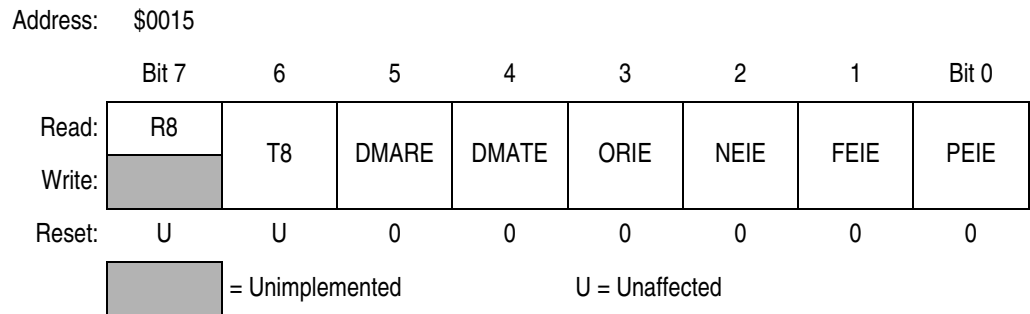
- 1 = Transmit break characters
- 0 = No break characters being transmitted

**NOTE:** *Do not toggle the SBK bit immediately after setting the SCTE bit. Toggling SBK before the preamble begins causes the SCI to send a break character instead of a preamble.*

13.11.3 SCI Control Register 3

SCI control register 3:

- Stores the ninth SCI data bit received and the ninth SCI data bit to be transmitted
- Enables the following interrupts:
  - Receiver overrun interrupts
  - Noise error interrupts
  - Framing error interrupts
  - Parity error interrupts



**Figure 13-14. SCI Control Register 3 (SCC3)**

**R8 — Received Bit 8**

When the SCI is receiving 9-bit characters, R8 is the read-only ninth bit (bit 8) of the received character. R8 is received at the same time that the SCDR receives the other 8 bits.

When the SCI is receiving 8-bit characters, R8 is a copy of the eighth bit (bit 7). Reset has no effect on the R8 bit.

**T8 — Transmitted Bit 8**

When the SCI is transmitting 9-bit characters, T8 is the read/write ninth bit (bit 8) of the transmitted character. T8 is loaded into the transmit shift register at the same time that the SCDR is loaded into the transmit shift register. Reset has no effect on the T8 bit.

## DMARE — DMA Receive Enable Bit

**CAUTION:** *The DMA module is not included on this MCU. Writing a logic 1 to DMARE or DMATE may adversely affect MCU performance.*

1 = DMA not enabled to service SCI receiver DMA service requests generated by the SCRF bit (SCI receiver CPU interrupt requests enabled)

0 = DMA not enabled to service SCI receiver DMA service requests generated by the SCRF bit (SCI receiver CPU interrupt requests enabled)

## DMATE — DMA Transfer Enable Bit

**CAUTION:** *The DMA module is not included on this MCU. Writing a logic 1 to DMARE or DMATE may adversely affect MCU performance.*

1 = SCTE DMA service requests enabled; SCTE CPU interrupt requests disabled

0 = SCTE DMA service requests disabled; SCTE CPU interrupt requests enabled

## ORIE — Receiver Overrun Interrupt Enable Bit

This read/write bit enables SCI error CPU interrupt requests generated by the receiver overrun bit, OR. Reset clears ORIE.

1 = SCI error CPU interrupt requests from OR bit enabled

0 = SCI error CPU interrupt requests from OR bit disabled

## NEIE — Receiver Noise Error Interrupt Enable Bit

This read/write bit enables SCI error CPU interrupt requests generated by the noise error bit, NE. Reset clears NEIE.

1 = SCI error CPU interrupt requests from NE bit enabled

0 = SCI error CPU interrupt requests from NE bit disabled

## FEIE — Receiver Framing Error Interrupt Enable Bit

This read/write bit enables SCI error CPU interrupt requests generated by the framing error bit, FE. Reset clears FEIE.

1 = SCI error CPU interrupt requests from FE bit enabled

0 = SCI error CPU interrupt requests from FE bit disabled

PEIE — Receiver Parity Error Interrupt Enable Bit

This read/write bit enables SCI error CPU interrupt requests generated by the parity error bit, PE. (See 13.11.4 SCI Status Register 1.) Reset clears PEIE.

- 1 = SCI error CPU interrupt requests from PE bit enabled
- 0 = SCI error CPU interrupt requests from PE bit disabled

13.11.4 SCI Status Register 1

SCI status register 1 contains flags to signal these conditions:

- Transfer of SCDR data to transmit shift register complete
- Transmission complete
- Transfer of receive shift register data to SCDR complete
- Receiver input idle
- Receiver overrun
- Noisy data
- Framing error
- Parity error

Address: \$0016

	Bit 7	6	5	4	3	2	1	Bit 0
Read:	SCTE	TC	SCRF	IDLE	OR	NF	FE	PE
Write:								
Reset:	1	1	0	0	0	0	0	0

= Unimplemented

Figure 13-15. SCI Status Register 1 (SCS1)

SCTE — SCI Transmitter Empty Bit

This clearable, read-only bit is set when the SCDR transfers a character to the transmit shift register. SCTE can generate an SCI transmitter CPU interrupt request. When the SCTIE bit in SCC2 is set, SCTE generates an SCI transmitter CPU interrupt request. In normal

operation, clear the SCTE bit by reading SCS1 with SCTE set and then writing to SCDR. Reset sets the SCTE bit.

- 1 = SCDR data transferred to transmit shift register
- 0 = SCDR data not transferred to transmit shift register

## TC — Transmission Complete Bit

This read-only bit is set when the SCTE bit is set, and no data, preamble, or break character is being transmitted. TC generates an SCI transmitter CPU interrupt request if the TCIE bit in SCC2 is also set. TC is automatically cleared when data, preamble or break is queued and ready to be sent. There may be up to 1.5 transmitter clocks of latency between queueing data, preamble, and break and the transmission actually starting. Reset sets the TC bit.

- 1 = No transmission in progress
- 0 = Transmission in progress

## SCRF — SCI Receiver Full Bit

This clearable, read-only bit is set when the data in the receive shift register transfers to the SCI data register. SCRF can generate an SCI receiver CPU interrupt request. When the SCRIE bit in SCC2 is set, SCRF generates a CPU interrupt request. In normal operation, clear the SCRF bit by reading SCS1 with SCRF set and then reading the SCDR. Reset clears SCRF.

- 1 = Received data available in SCDR
- 0 = Data not available in SCDR

## IDLE — Receiver Idle Bit

This clearable, read-only bit is set when 10 or 11 consecutive logic 1s appear on the receiver input. IDLE generates an SCI receiver CPU interrupt request if the ILIE bit in SCC2 is also set. Clear the IDLE bit by reading SCS1 with IDLE set and then reading the SCDR. After the receiver is enabled, it must receive a valid character that sets the SCRF bit before an idle condition can set the IDLE bit. Also, after the IDLE bit has been cleared, a valid character must again set the SCRF bit before an idle condition can set the IDLE bit. Reset clears the IDLE bit.

- 1 = Receiver input idle
- 0 = Receiver input active (or idle since the IDLE bit was cleared)

## OR — Receiver Overrun Bit

This clearable, read-only bit is set when software fails to read the SCDR before the receive shift register receives the next character. The OR bit generates an SCI error CPU interrupt request if the ORIE bit in SCC3 is also set. The data in the shift register is lost, but the data already in the SCDR is not affected. Clear the OR bit by reading SCS1 with OR set and then reading the SCDR. Reset clears the OR bit.

1 = Receive shift register full and SCRF = 1

0 = No receiver overrun

Software latency may allow an overrun to occur between reads of SCS1 and SCDR in the flag-clearing sequence. **Figure 13-16** shows the normal flag-clearing sequence and an example of an overrun caused by a delayed flag-clearing sequence. The delayed read of SCDR does not clear the OR bit because OR was not set when SCS1 was read. Byte 2 caused the overrun and is lost. The next flag-clearing sequence reads byte 3 in the SCDR instead of byte 2.

In applications that are subject to software latency or in which it is important to know which byte is lost due to an overrun, the flag-clearing routine can check the OR bit in a second read of SCS1 after reading the data register.

## NF — Receiver Noise Flag Bit

This clearable, read-only bit is set when the SCI detects noise on the RxD pin. NF generates an SCI error CPU interrupt request if the NEIE bit in SCC3 is also set. Clear the NF bit by reading SCS1 and then reading the SCDR. Reset clears the NF bit.

1 = Noise detected

0 = No noise detected

## FE — Receiver Framing Error Bit

This clearable, read-only bit is set when a logic 0 is accepted as the stop bit. FE generates an SCI error CPU interrupt request if the FEIE bit in SCC3 also is set. Clear the FE bit by reading SCS1 with FE set and then reading the SCDR. Reset clears the FE bit.

1 = Framing error detected

0 = No framing error detected

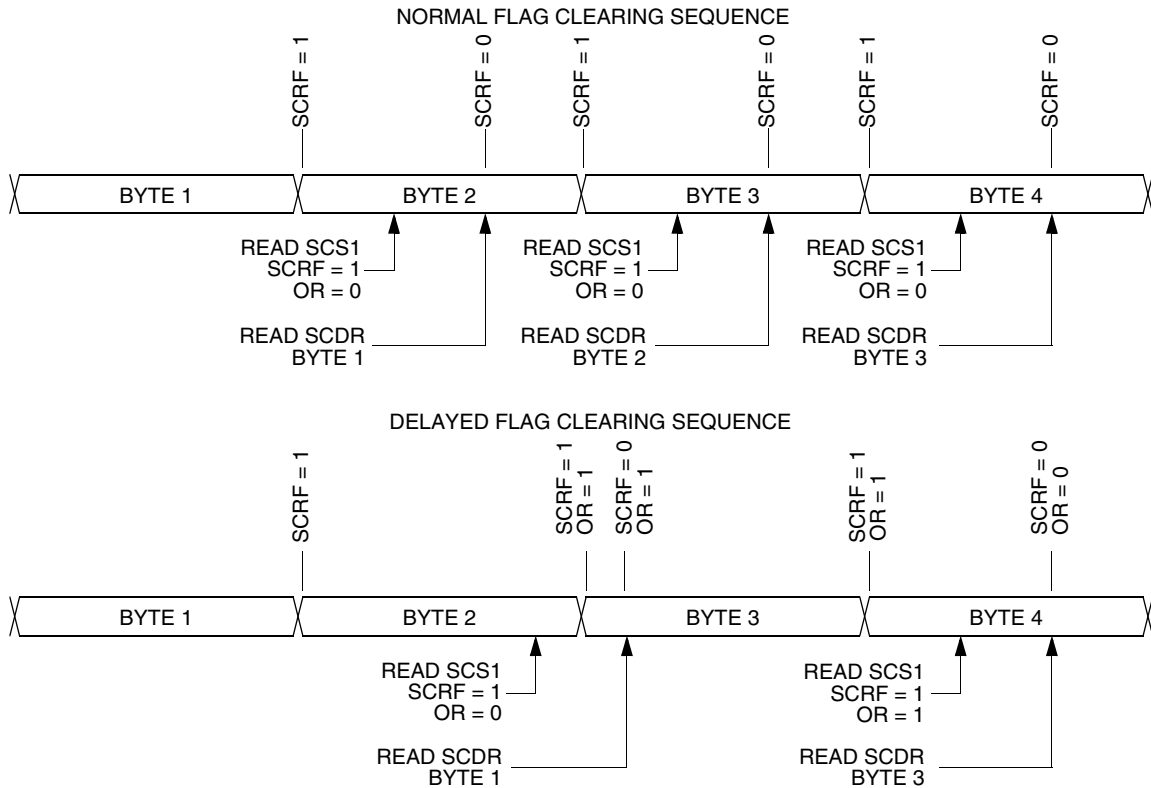


Figure 13-16. Flag Clearing Sequence

PE — Receiver Parity Error Bit

This clearable, read-only bit is set when the SCI detects a parity error in incoming data. PE generates an SCI error CPU interrupt request if the PEIE bit in SCC3 is also set. Clear the PE bit by reading SCS1 with PE set and then reading the SCDR. Reset clears the PE bit.

- 1 = Parity error detected
- 0 = No parity error detected

13.11.5 SCI Status Register 2 (SCS2)

SCI status register 2 contains flags to signal the following conditions:

- Break character detected
- Incoming data

Address: \$0017

	Bit 7	6	5	4	3	2	1	Bit 0
Read:	0	0	0	0	0	0	BKF	RPF
Write:								
Reset:	0	0	0	0	0	0	0	0


 = Unimplemented

Figure 13-17. SCI Status Register 2 (SCS2)

BKF — Break Flag Bit

This clearable, read-only bit is set when the SCI detects a break character on the RxD pin. In SCS1, the FE and SCRF bits are also set. In 9-bit character transmissions, the R8 bit in SCC3 is cleared. BKF does not generate a CPU interrupt request. Clear BKF by reading SCS2 with BKF set and then reading the SCDR. Once cleared, BKF can become set again only after logic 1s again appear on the RxD pin followed by another break character. Reset clears the BKF bit.

- 1 = Break character detected
- 0 = No break character detected

RPF — Reception in Progress Flag Bit

This read-only bit is set when the receiver detects a logic 0 during the RT1 time period of the start bit search. RPF does not generate an interrupt request. RPF is reset after the receiver detects false start bits (usually from noise or a baud rate mismatch) or when the receiver detects an idle character. Polling RPF before disabling the SCI module or entering stop mode can show whether a reception is in progress.

- 1 = Reception in progress
- 0 = No reception in progress



**13.11.6 SCI Data Register**

The SCI data register is the buffer between the internal data bus and the receive and transmit shift registers. Reset has no effect on data in the SCI data register.

Address: \$0018

	Bit 7	6	5	4	3	2	1	Bit 0
Read:	R7	R6	R5	R4	R3	R2	R1	R0
Write:	T7	T6	T5	T4	T3	T2	T1	T0
Reset:	Unaffected by reset							

**Figure 13-18. SCI Data Register (SCDR)**

R7/T7–R0/T0 — Receive/Transmit Data Bits

Reading the SCDR accesses the read-only received data bits, R7–R0. Writing to the SCDR writes the data to be transmitted, T7–T0. Reset has no effect on the SCDR.

**NOTE:** *Do not use read/modify/write instructions on the SCI data register.*

13.11.7 SCI Baud Rate Register

The baud rate register selects the baud rate for both the receiver and the transmitter.

Address: \$0019

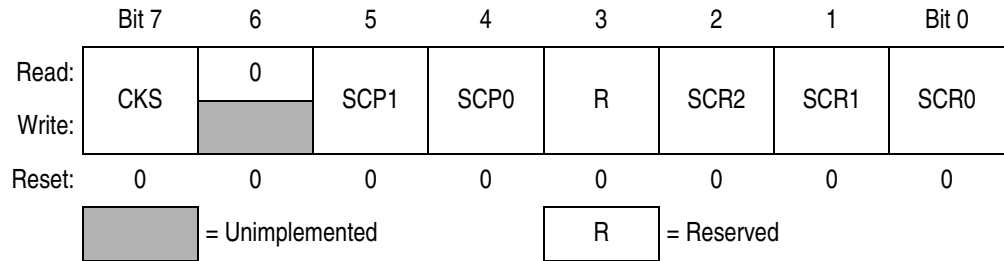


Figure 13-19. SCI Baud Rate Register (SCBR)

CKS — Baud Clock Input Select

This read/write bit selects the source clock for the baud rate generator. Reset clears the CKS bit, selecting CGMXCLK.

- 1 = Bus clock drives the baud rate generator
- 0 = CGMXCLK drives the baud rate generator

SCP1 and SCP0 — SCI Baud Rate Prescaler Bits

These read/write bits select the baud rate prescaler divisor as shown in Table 13-7. Reset clears SCP1 and SCP0.

Table 13-7. SCI Baud Rate Prescaling

SCP1 and SCP0	Prescaler Divisor (PD)
00	1
01	3
10	4
11	13

SCR2–SCR0 — SCI Baud Rate Select Bits

These read/write bits select the SCI baud rate divisor as shown in Table 13-8. Reset clears SCR2–SCR0.

**Table 13-8. SCI Baud Rate Selection**

SCR2, SCR1, and SCR0	Baud Rate Divisor (BD)
000	1
001	2
010	4
011	8
100	16
101	32
110	64
111	128

Use this formula to calculate the SCI baud rate:

$$\text{baud rate} = \frac{\text{SCI clock source}}{16 \times \text{PD} \times \text{BD}}$$

where:

SCI clock source =  $f_{\text{BUS}}$  or CGMXCLK

(selected by CKS bit)

PD = prescaler divisor

BD = baud rate divisor

**Table 13-9** shows the SCI baud rates that can be generated with a 4.9152-MHz bus clock when  $f_{\text{BUS}}$  is selected as SCI clock source.

Table 13-9. SCI Baud Rate Selection Examples

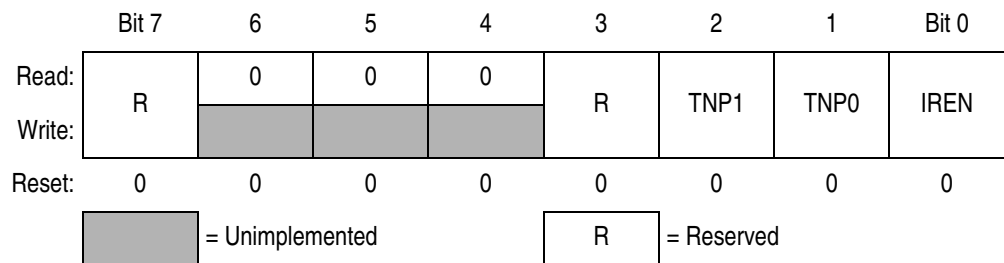
SCP1 and SCP0	Prescaler Divisor (PD)	SCR2, SCR1, and SCR0	Baud Rate Divisor (BD)	Baud Rate (f <sub>BUS</sub> = 4.9152 MHz)
00	1	000	1	—
00	1	001	2	—
00	1	010	4	76800
00	1	011	8	38400
00	1	100	16	19200
00	1	101	32	9600
00	1	110	64	4800
00	1	111	128	2400
01	3	000	1	—
01	3	001	2	51200
01	3	010	4	25600
01	3	011	8	12800
01	3	100	16	6400
01	3	101	32	3200
01	3	110	64	1600
01	3	111	128	800
10	4	000	1	76800
10	4	001	2	38400
10	4	010	4	19200
10	4	011	8	9600
10	4	100	16	4800
10	4	101	32	2400
10	4	110	64	1200
10	4	111	128	600
11	13	000	1	23632
11	13	001	2	11816
11	13	010	4	5908
11	13	011	8	2954
11	13	100	16	1477
11	13	101	32	739
11	13	110	64	369
11	13	111	128	185

**13.11.8 SCI Infrared Control Register**

The infrared control register contains the control bits for the infrared sub-module.

- Enables the infrared sub-module
- Selects the infrared transmitter narrow pulse width

Address: \$001A



**Figure 13-20. SCI Infrared Control Register (SCIRCR)**

**TNP1 and TNP0 — Transmitter Narrow Pulse Bits**

These read/write bits select the infrared transmitter narrow pulse width as shown in [Table 13-10](#). Reset clears TNP1 and TNP0.

**Table 13-10. Infrared Narrow Pulse Selection**

TNP1 and TNP0	Prescaler Divisor (PD)
00	SCI transmits a 3/16 narrow pulse
01	SCI transmits a 1/16 narrow pulse
10	SCI transmits a 1/32 narrow pulse
11	

**IREN — Infrared Enable Bit**

This read/write bit enables the infrared sub-module for encoding and decoding the SCI data stream. When this bit is clear, the infrared sub-module is disabled. Reset clears the IREN bit.

- 1 = Infrared sub-module enabled
- 0 = Infrared sub-module disabled



## Section 14. Serial Peripheral Interface Module (SPI)

### 14.1 Contents

14.2	Introduction	288
14.3	Features	288
14.4	Pin Name Conventions and I/O Register Addresses	289
14.5	Functional Description	290
14.5.1	Master Mode	291
14.5.2	Slave Mode	292
14.6	Transmission Formats	293
14.6.1	Clock Phase and Polarity Controls	293
14.6.2	Transmission Format When CPHA = 0	294
14.6.3	Transmission Format When CPHA = 1	296
14.6.4	Transmission Initiation Latency	297
14.7	Queuing Transmission Data	299
14.8	Error Conditions	300
14.8.1	Overflow Error	300
14.8.2	Mode Fault Error	302
14.9	Interrupts	304
14.10	Resetting the SPI	306
14.11	Low-Power Modes	307
14.11.1	Wait Mode	307
14.11.2	Stop Mode	307
14.12	SPI During Break Interrupts	308
14.13	I/O Signals	308
14.13.1	MISO (Master In/Slave Out)	309
14.13.2	MOSI (Master Out/Slave In)	309

14.13.3 SPSCK (Serial Clock).....310  
 14.13.4  $\overline{SS}$  (Slave Select) .....310  
 14.13.5 CGND (Clock Ground) .....311  
 14.14 I/O Registers.....312  
 14.14.1 SPI Control Register.....312  
 14.14.2 SPI Status and Control Register .....314  
 14.14.3 SPI Data Register.....317

**14.2 Introduction**

This section describes the serial peripheral interface (SPI) module, which allows full-duplex, synchronous, serial communications with peripheral devices.

**14.3 Features**

Features of the SPI module include the following:

- Full-duplex operation
- Master and slave modes
- Double-buffered operation with separate transmit and receive registers
- Four master mode frequencies (maximum = bus frequency  $\div$  2)
- Maximum slave mode frequency = bus frequency
- Serial clock with programmable polarity and phase
- Two separately enabled interrupts:
  - SPRF (SPI receiver full)
  - SPTE (SPI transmitter empty)
- Mode fault error flag with CPU interrupt capability
- Overflow error flag with CPU interrupt capability
- Programmable wired-OR mode



### 14.4 Pin Name Conventions and I/O Register Addresses

The text that follows describes the SPI. The SPI I/O pin names are  $\overline{SS}$  (slave select), SPSCCK (SPI serial clock), CGND (clock ground), MOSI (master out slave in), and MISO (master in/slave out). The SPI shares four I/O pins with four parallel I/O ports.

The full names of the SPI I/O pins are shown in [Table 14-1](#). The generic pin names appear in the text that follows.

**Table 14-1. Pin Name Conventions**

SPI Generic Pin Names:		MISO	MOSI	$\overline{SS}$	SPSCCK	CGND
Full SPI Pin Names:	SPI	PTD1/MISO	PTD2/MOSI	PTD0/ $\overline{SS}$ CALIN	PTD3/SPSCCK/ CALOUT	V <sub>SS</sub>

**NOTE:** The  $\overline{SS}$  and SPSCCK pins are also shared with CALIN and CALOUT respectively. To avoid erratic behavior, these two pins should never be configured for use as SPI and RTC calibration simultaneously.

[Figure 14-1](#) summarizes the SPI I/O registers.

Addr.	Register Name	Bit 7	6	5	4	3	2	1	Bit 0	
\$0010	SPI Control Register (SPCR)	Read:	SPRIE	R	SPMSTR	CPOL	CPHA	SPWOM	SPE	SPTIE
		Write:								
		Reset:	0	0	1	0	1	0	0	0
\$0011	SPI Status and Control Register (SPSCR)	Read:	SPRF	ERRIE	OVRF	MODF	SPTIE	MODFEN	SPR1	SPR0
		Write:								
		Reset:	0	0	0	0	1	0	0	0
\$0012	SPI Data Register (SPDR)	Read:	R7	R6	R5	R4	R3	R2	R1	R0
		Write:	T7	T6	T5	T4	T3	T2	T1	T0
		Reset:	Unaffected by reset							

= Unimplemented
  = Reserved

**Figure 14-1. SPI I/O Register Summary**

14.5 Functional Description

Figure 14-2 shows the structure of the SPI module.

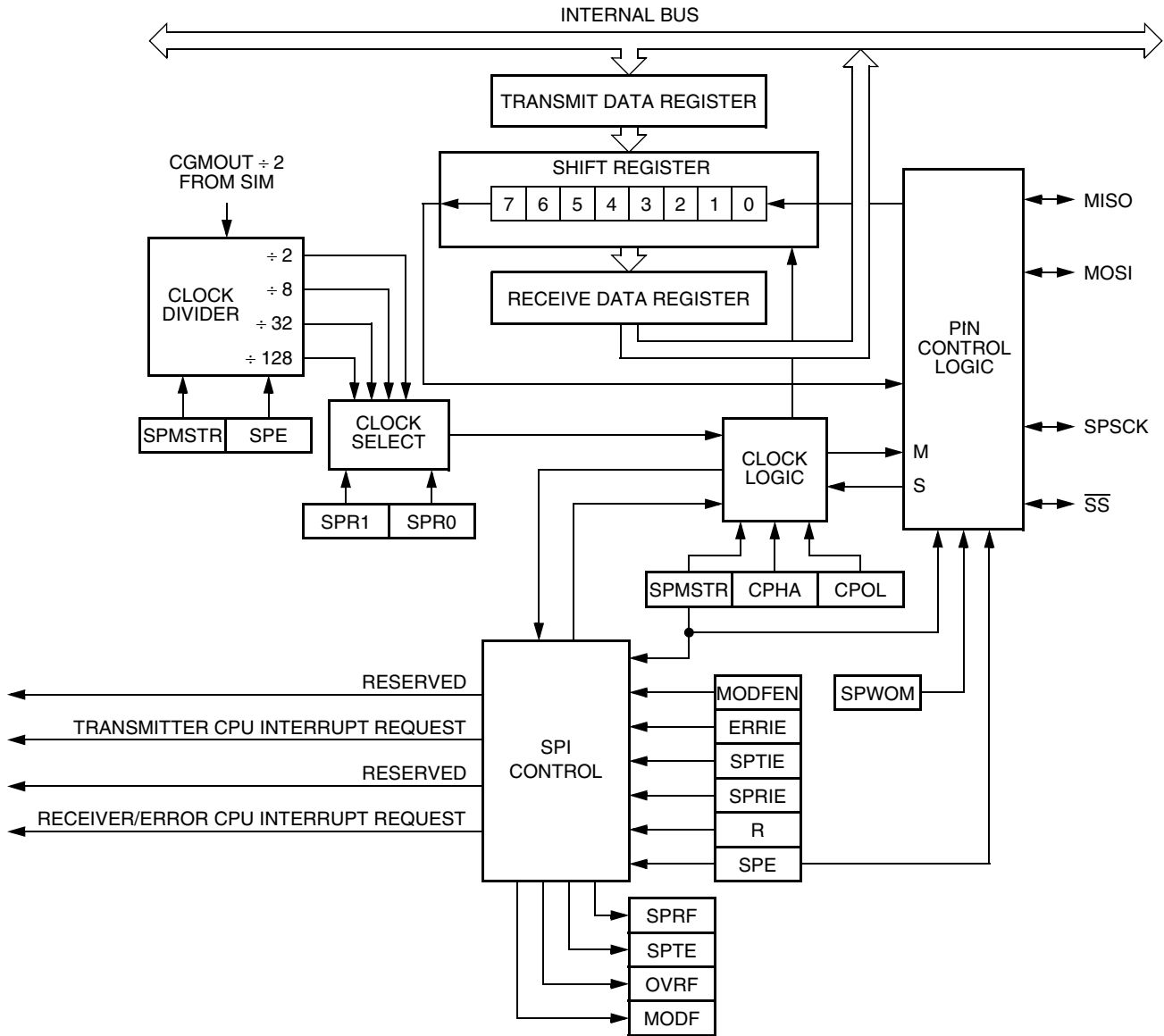


Figure 14-2. SPI Module Block Diagram

The SPI module allows full-duplex, synchronous, serial communication between the MCU and peripheral devices, including other MCUs. Software can poll the SPI status flags or SPI operation can be interrupt-driven.

The following paragraphs describe the operation of the SPI module.

14.5.1 Master Mode

The SPI operates in master mode when the SPI master bit, SPMSTR, is set.

**NOTE:** *Configure the SPI modules as master or slave before enabling them. Enable the master SPI before enabling the slave SPI. Disable the slave SPI before disabling the master SPI. (See [14.14.1 SPI Control Register](#).)*

Only a master SPI module can initiate transmissions. Software begins the transmission from a master SPI module by writing to the transmit data register. If the shift register is empty, the byte immediately transfers to the shift register, setting the SPI transmitter empty bit, SPTE. The byte begins shifting out on the MOSI pin under the control of the serial clock. (See [Figure 14-3](#).)

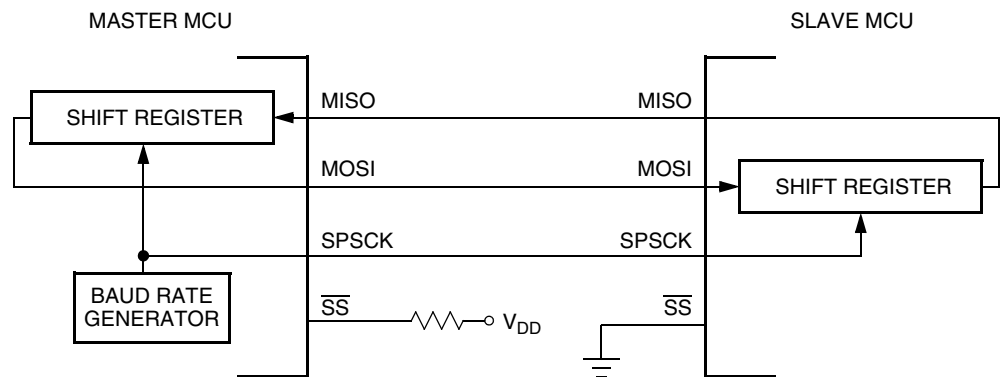


Figure 14-3. Full-Duplex Master-Slave Connections

The SPR1 and SPR0 bits control the baud rate generator and determine the speed of the shift register. (See [14.14.2 SPI Status and Control Register](#).) Through the SPSCCK pin, the baud rate generator of the master also controls the shift register of the slave peripheral.

As the byte shifts out on the MOSI pin of the master, another byte shifts in from the slave on the master's MISO pin. The transmission ends when the receiver full bit, SPRF, becomes set. At the same time that SPRF becomes set, the byte from the slave transfers to the receive data register. In normal operation, SPRF signals the end of a transmission. Software clears SPRF by reading the SPI status and control register with SPRF set and then reading the SPI data register. Writing to the SPI data register clears the SPTE bit.

### 14.5.2 Slave Mode

The SPI operates in slave mode when the SPMSTR bit is clear. In slave mode, the SPSCCK pin is the input for the serial clock from the master MCU. Before a data transmission occurs, the  $\overline{SS}$  pin of the slave SPI must be at logic 0.  $\overline{SS}$  must remain low until the transmission is complete. (See [14.8.2 Mode Fault Error](#).)

In a slave SPI module, data enters the shift register under the control of the serial clock from the master SPI module. After a byte enters the shift register of a slave SPI, it transfers to the receive data register, and the SPRF bit is set. To prevent an overflow condition, slave software then must read the receive data register before another full byte enters the shift register.

The maximum frequency of the SPSCCK for an SPI configured as a slave is the bus clock speed (which is twice as fast as the fastest master SPSCCK clock that can be generated). The frequency of the SPSCCK for an SPI configured as a slave does not have to correspond to any SPI baud rate. The baud rate only controls the speed of the SPSCCK generated by an SPI configured as a master. Therefore, the frequency of the SPSCCK for an SPI configured as a slave can be any frequency less than or equal to the bus speed.

When the master SPI starts a transmission, the data in the slave shift register begins shifting out on the MISO pin. The slave can load its shift register with a new byte for the next transmission by writing to its transmit data register. The slave must write to its transmit data register at least one bus cycle before the master starts the next transmission. Otherwise, the byte already in the slave shift register shifts out on the MISO pin. Data written to the slave shift register during a transmission remains in a buffer until the end of the transmission.

When the clock phase bit (CPHA) is set, the first edge of SPSCCK starts a transmission. When CPHA is clear, the falling edge of  $\overline{SS}$  starts a transmission. (See [14.6 Transmission Formats](#).)

**NOTE:** *SPSCCK must be in the proper idle state before the slave is enabled to prevent SPSCCK from appearing as a clock edge.*

## 14.6 Transmission Formats

During an SPI transmission, data is simultaneously transmitted (shifted out serially) and received (shifted in serially). A serial clock synchronizes shifting and sampling on the two serial data lines. A slave select line allows selection of an individual slave SPI device; slave devices that are not selected do not interfere with SPI bus activities. On a master SPI device, the slave select line can optionally be used to indicate multiple-master bus contention.

### 14.6.1 Clock Phase and Polarity Controls

Software can select any of four combinations of serial clock (SPSCCK) phase and polarity using two bits in the SPI control register (SPCR). The clock polarity is specified by the CPOL control bit, which selects an active high or low clock and has no significant effect on the transmission format.

The clock phase (CPHA) control bit selects one of two fundamentally different transmission formats. The clock phase and polarity should be identical for the master SPI device and the communicating slave device. In some cases, the phase and polarity are changed between transmissions to allow a master device to communicate with peripheral slaves having different requirements.

**NOTE:** Before writing to the CPOL bit or the CPHA bit, disable the SPI by clearing the SPI enable bit (SPE).

#### 14.6.2 Transmission Format When CPHA = 0

**Figure 14-4** shows an SPI transmission in which CPHA is logic 0. The figure should not be used as a replacement for data sheet parametric information.

Two waveforms are shown for SPSCK: one for CPOL = 0 and another for CPOL = 1. The diagram may be interpreted as a master or slave timing diagram since the serial clock (SPSCK), master in/slave out (MISO), and master out/slave in (MOSI) pins are directly connected between the master and the slave. The MISO signal is the output from the slave, and the MOSI signal is the output from the master. The  $\overline{SS}$  line is the slave select input to the slave. The slave SPI drives its MISO output only when its slave select input ( $\overline{SS}$ ) is at logic 0, so that only the selected slave drives to the master. The  $\overline{SS}$  pin of the master is not shown but is assumed to be inactive. The  $\overline{SS}$  pin of the master must be high or must be reconfigured as general-purpose I/O not affecting the SPI. (See **14.8.2 Mode Fault Error**.) When CPHA = 0, the first SPSCK edge is the MSB capture strobe. Therefore, the slave must begin driving its data before the first SPSCK edge, and a falling edge on the  $\overline{SS}$  pin is used to start the slave data transmission. The slave's  $\overline{SS}$  pin must be toggled back to high and then low again between each byte transmitted as shown in **Figure 14-5**.

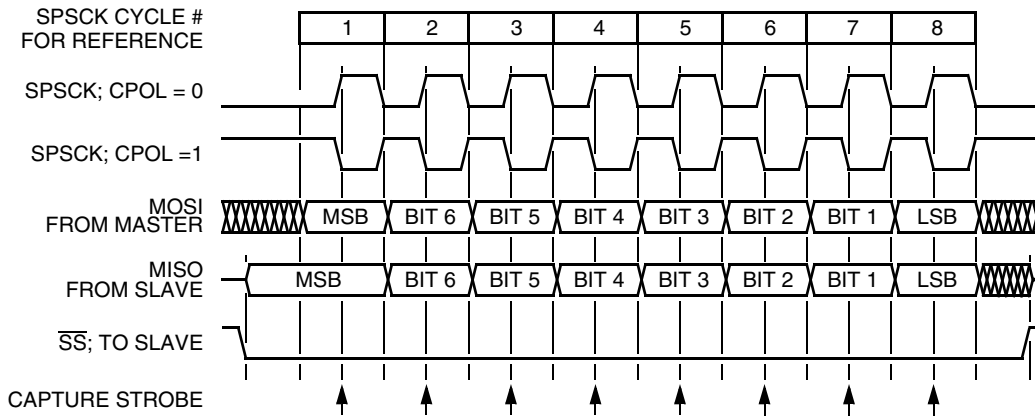


Figure 14-4. Transmission Format (CPHA = 0)

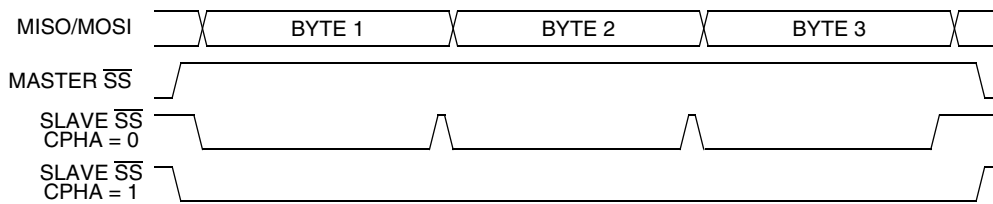


Figure 14-5. CPHA/SS Timing

When CPHA = 0 for a slave, the falling edge of  $\overline{SS}$  indicates the beginning of the transmission. This causes the SPI to leave its idle state and begin driving the MISO pin with the MSB of its data. Once the transmission begins, no new data is allowed into the shift register from the transmit data register. Therefore, the SPI data register of the slave must be loaded with transmit data before the falling edge of  $\overline{SS}$ . Any data written after the falling edge is stored in the transmit data register and transferred to the shift register after the current transmission.

Serial Peripheral Interface Module (SPI)

14.6.3 Transmission Format When CPHA = 1

Figure 14-6 shows an SPI transmission in which CPHA is logic 1. The figure should not be used as a replacement for data sheet parametric information. Two waveforms are shown for SPSCCK: one for CPOL = 0 and another for CPOL = 1. The diagram may be interpreted as a master or slave timing diagram since the serial clock (SPSCCK), master in/slave out (MISO), and master out/slave in (MOSI) pins are directly connected between the master and the slave. The MISO signal is the output from the slave, and the MOSI signal is the output from the master. The  $\overline{SS}$  line is the slave select input to the slave. The slave SPI drives its MISO output only when its slave select input ( $\overline{SS}$ ) is at logic 0, so that only the selected slave drives to the master. The  $\overline{SS}$  pin of the master is not shown but is assumed to be inactive. The  $\overline{SS}$  pin of the master must be high or must be reconfigured as general-purpose I/O not affecting the SPI. (See 14.8.2 Mode Fault Error.) When CPHA = 1, the master begins driving its MOSI pin on the first SPSCCK edge. Therefore, the slave uses the first SPSCCK edge as a start transmission signal. The  $\overline{SS}$  pin can remain low between transmissions. This format may be preferable in systems having only one master and only one slave driving the MISO data line.

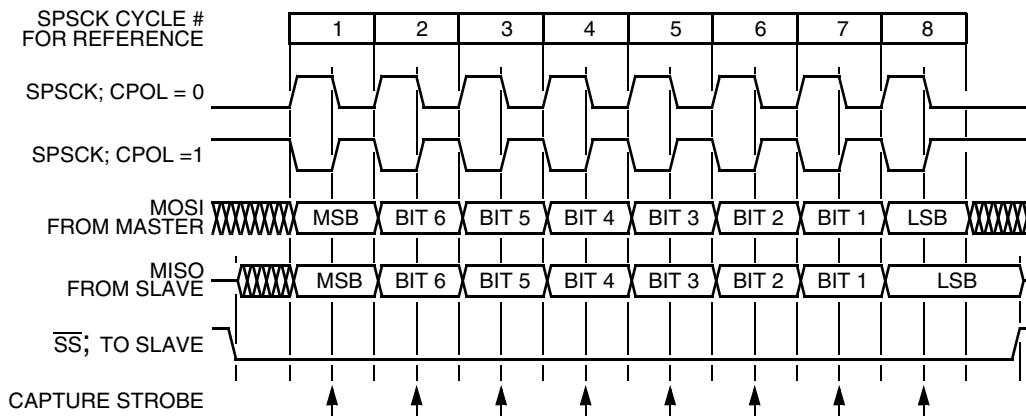


Figure 14-6. Transmission Format (CPHA = 1)



When  $CPHA = 1$  for a slave, the first edge of the  $SPSCK$  indicates the beginning of the transmission. This causes the SPI to leave its idle state and begin driving the  $MISO$  pin with the  $MSB$  of its data. Once the transmission begins, no new data is allowed into the shift register from the transmit data register. Therefore, the SPI data register of the slave must be loaded with transmit data before the first edge of  $SPSCK$ . Any data written after the first edge is stored in the transmit data register and transferred to the shift register after the current transmission.

#### 14.6.4 Transmission Initiation Latency

When the SPI is configured as a master ( $SPMSTR = 1$ ), writing to the  $SPDR$  starts a transmission.  $CPHA$  has no effect on the delay to the start of the transmission, but it does affect the initial state of the  $SPSCK$  signal. When  $CPHA = 0$ , the  $SPSCK$  signal remains inactive for the first half of the first  $SPSCK$  cycle. When  $CPHA = 1$ , the first  $SPSCK$  cycle begins with an edge on the  $SPSCK$  line from its inactive to its active level. The SPI clock rate (selected by  $SPR1:SPR0$ ) affects the delay from the write to  $SPDR$  and the start of the SPI transmission. (See [Figure 14-7](#).) The internal SPI clock in the master is a free-running derivative of the internal MCU clock. To conserve power, it is enabled only when both the  $SPE$  and  $SPMSTR$  bits are set.  $SPSCK$  edges occur halfway through the low time of the internal MCU clock. Since the SPI clock is free-running, it is uncertain where the write to the  $SPDR$  occurs relative to the slower  $SPSCK$ . This uncertainty causes the variation in the initiation delay shown in [Figure 14-7](#). This delay is no longer than a single SPI bit time. That is, the maximum delay is two MCU bus cycles for  $DIV2$ , eight MCU bus cycles for  $DIV8$ , 32 MCU bus cycles for  $DIV32$ , and 128 MCU bus cycles for  $DIV128$ .

Serial Peripheral Interface Module (SPI)

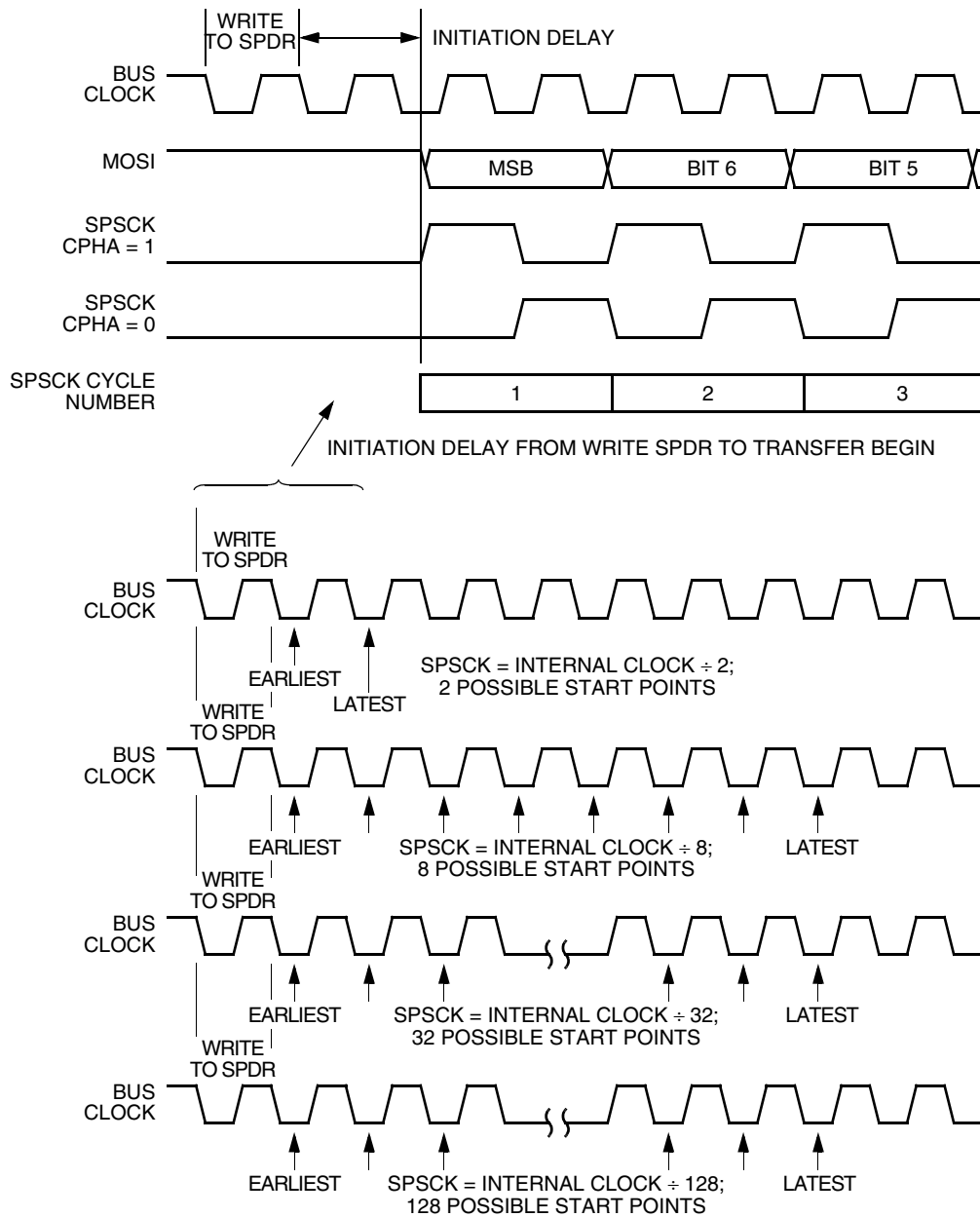
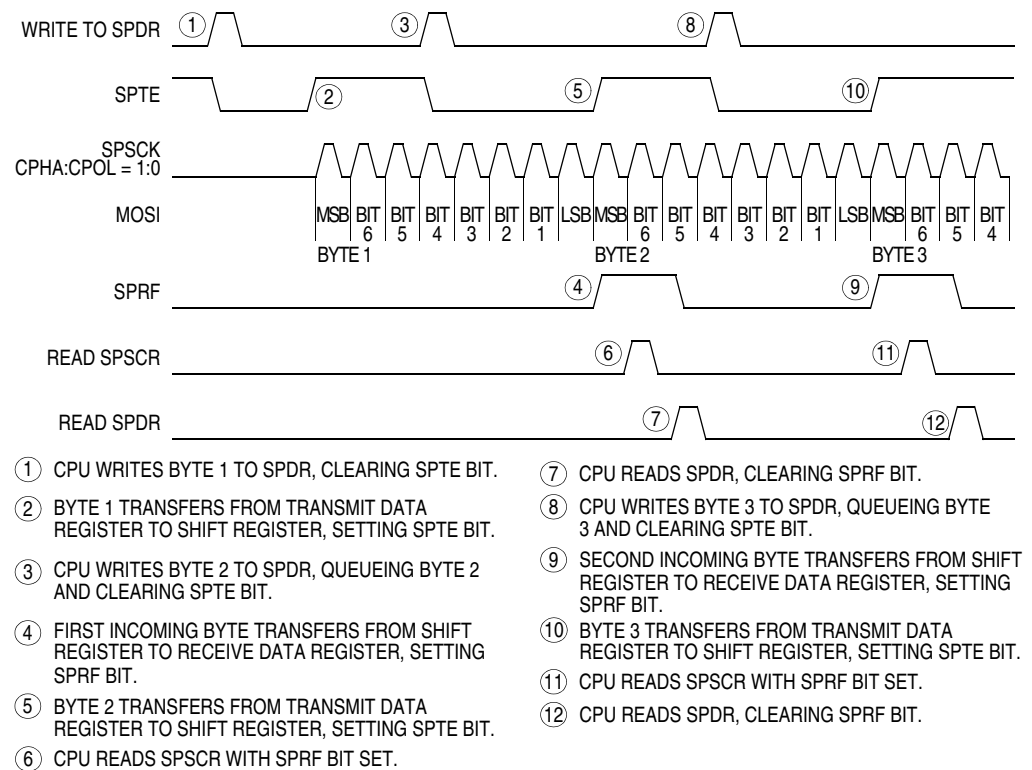


Figure 14-7. Transmission Start Delay (Master)

## 14.7 Queuing Transmission Data

The double-buffered transmit data register allows a data byte to be queued and transmitted. For an SPI configured as a master, a queued data byte is transmitted immediately after the previous transmission has completed. The SPI transmitter empty flag (SPTE) indicates when the transmit data buffer is ready to accept new data. Write to the transmit data register only when the SPTE bit is high. **Figure 14-8** shows the timing associated with doing back-to-back transmissions with the SPI (SPSCK has CPHA: CPOL = 1:0).



**Figure 14-8. SPRF/SPTE CPU Interrupt Timing**

The transmit data buffer allows back-to-back transmissions without the slave precisely timing its writes between transmissions as in a system with a single data buffer. Also, if no new data is written to the data buffer, the last value contained in the shift register is the next data word to be transmitted.

For an idle master or idle slave that has no data loaded into its transmit buffer, the SPTE is set again no more than two bus cycles after the transmit buffer empties into the shift register. This allows the user to queue up a 16-bit value to send. For an already active slave, the load of the shift register cannot occur until the transmission is completed. This implies that a back-to-back write to the transmit data register is not possible. The SPTE indicates when the next write can occur.

## 14.8 Error Conditions

The following flags signal SPI error conditions:

- Overflow (OVRF) — Failing to read the SPI data register before the next full byte enters the shift register sets the OVRF bit. The new byte does not transfer to the receive data register, and the unread byte still can be read. OVRF is in the SPI status and control register.
- Mode fault error (MODF) — The MODF bit indicates that the voltage on the slave select pin ( $\overline{SS}$ ) is inconsistent with the mode of the SPI. MODF is in the SPI status and control register.

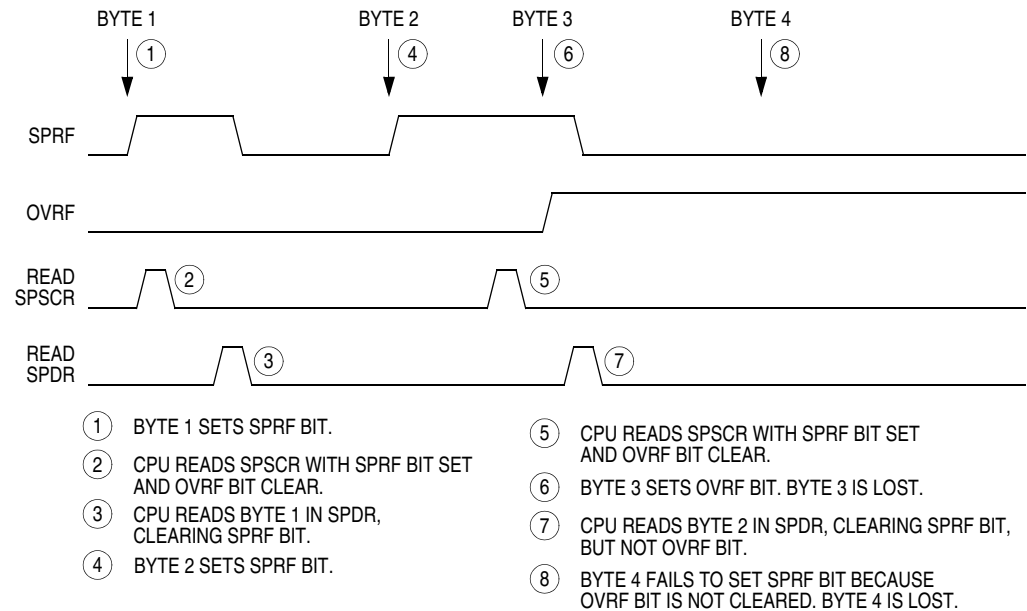
### 14.8.1 Overflow Error

The overflow flag (OVRF) becomes set if the receive data register still has unread data from a previous transmission when the capture strobe of bit 1 of the next transmission occurs. The bit 1 capture strobe occurs in the middle of SPSCCK cycle 7. (See [Figure 14-4](#) and [Figure 14-6](#).) If an overflow occurs, all data received after the overflow and before the OVRF bit is cleared does not transfer to the receive data register and does not set the SPI receiver full bit (SPRF). The unread data that transferred to the receive data register before the overflow occurred can still be read. Therefore, an overflow error always indicates the loss of data. Clear the overflow flag by reading the SPI status and control register and then reading the SPI data register.

OVRF generates a receiver/error CPU interrupt request if the error interrupt enable bit (ERRIE) is also set. The SPRF, MODF, and OVRF

interrupts share the same CPU interrupt vector. (See [Figure 14-11](#).) It is not possible to enable MODF or OVRF individually to generate a receiver/error CPU interrupt request. However, leaving MODFEN low prevents MODF from being set.

If the CPU SPRF interrupt is enabled and the OVRF interrupt is not, watch for an overflow condition. [Figure 14-9](#) shows how it is possible to miss an overflow. The first part of [Figure 14-9](#) shows how it is possible to read the SPSCR and SPDR to clear the SPRF without problems. However, as illustrated by the second transmission example, the OVRF bit can be set in between the time that SPSCR and SPDR are read.



**Figure 14-9. Missed Read of Overflow Condition**

In this case, an overflow can be missed easily. Since no more SPRF interrupts can be generated until this OVRF is serviced, it is not obvious that bytes are being lost as more transmissions are completed. To prevent this, either enable the OVRF interrupt or do another read of the SPSCR following the read of the SPDR. This ensures that the OVRF was not set before the SPRF was cleared and that future transmissions can set the SPRF bit. [Figure 14-10](#) illustrates this process. Generally, to avoid this second SPSCR read, enable the OVRF to the CPU by setting the ERRIE bit.

Serial Peripheral Interface Module (SPI)

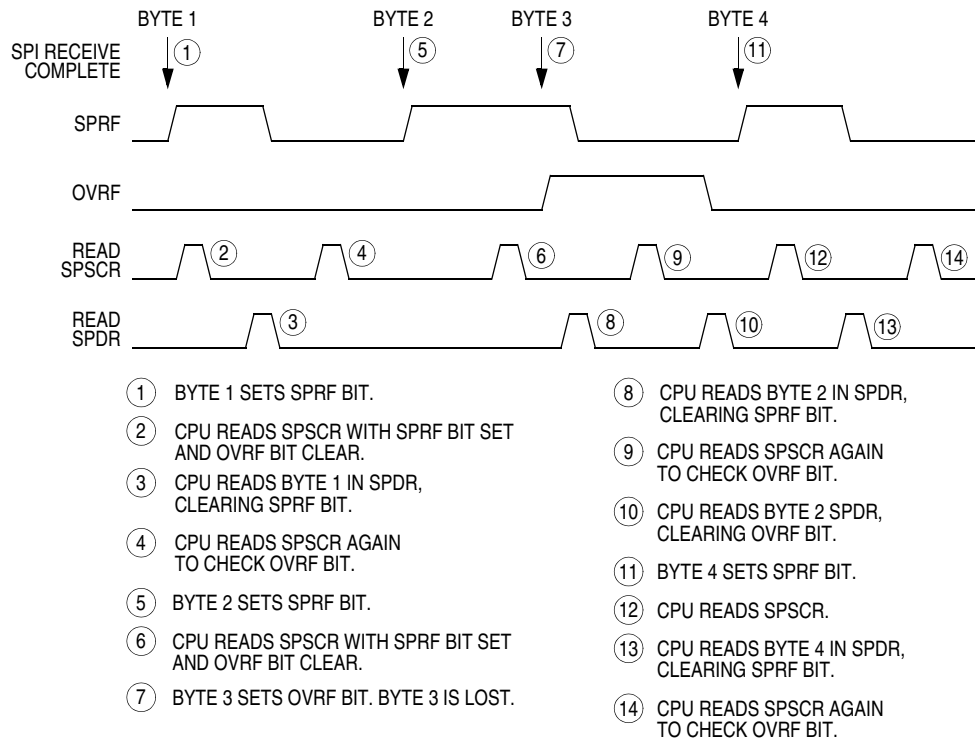


Figure 14-10. Clearing SPRF When OVRF Interrupt Is Not Enabled

14.8.2 Mode Fault Error

Setting the SPMSTR bit selects master mode and configures the SPSCCK and MOSI pins as outputs and the MISO pin as an input. Clearing SPMSTR selects slave mode and configures the SPSCCK and MOSI pins as inputs and the MISO pin as an output. The mode fault bit, MODF, becomes set any time the state of the slave select pin,  $\overline{SS}$ , is inconsistent with the mode selected by SPMSTR.

To prevent SPI pin contention and damage to the MCU, a mode fault error occurs if:

- The  $\overline{SS}$  pin of a slave SPI goes high during a transmission
- The  $\overline{SS}$  pin of a master SPI goes low at any time

For the MODF flag to be set, the mode fault error enable bit (MODFEN) must be set. Clearing the MODFEN bit does not clear the MODF flag but does prevent MODF from being set again after MODF is cleared.

MODF generates a receiver/error CPU interrupt request if the error interrupt enable bit (ERRIE) is also set. The SPRF, MODF, and OVRF interrupts share the same CPU interrupt vector. (See [Figure 14-11](#).) It is not possible to enable MODF or OVRF individually to generate a receiver/error CPU interrupt request. However, leaving MODFEN low prevents MODF from being set.

In a master SPI with the mode fault enable bit (MODFEN) set, the mode fault flag (MODF) is set if  $\overline{SS}$  goes to logic 0. A mode fault in a master SPI causes the following events to occur:

- If  $ERRIE = 1$ , the SPI generates an SPI receiver/error CPU interrupt request.
- The SPE bit is cleared.
- The SPTE bit is set.
- The SPI state counter is cleared.
- The data direction register of the shared I/O port regains control of port drivers.

**NOTE:** *To prevent bus contention with another master SPI after a mode fault error, clear all SPI bits of the data direction register of the shared I/O port before enabling the SPI.*

When configured as a slave ( $SPMSTR = 0$ ), the MODF flag is set if  $\overline{SS}$  goes high during a transmission. When  $CPHA = 0$ , a transmission begins when  $\overline{SS}$  goes low and ends once the incoming SPSCCK goes back to its idle level following the shift of the eighth data bit. When  $CPHA = 1$ , the transmission begins when the SPSCCK leaves its idle level and  $\overline{SS}$  is already low. The transmission continues until the SPSCCK returns to its idle level following the shift of the last data bit. (See [14.6 Transmission Formats](#).)

**NOTE:** *Setting the MODF flag does not clear the SPMSTR bit. The SPMSTR bit has no function when  $SPE = 0$ . Reading SPMSTR when  $MODF = 1$  shows the difference between a MODF occurring when the SPI is a master and when it is a slave.*

*When  $CPHA = 0$ , a MODF occurs if a slave is selected ( $\overline{SS}$  is at logic 0) and later unselected ( $\overline{SS}$  is at logic 1) even if no SPSCCK is sent to that*

slave. This happens because  $\overline{SS}$  at logic 0 indicates the start of the transmission (MISO driven out with the value of MSB) for  $CPHA = 0$ . When  $CPHA = 1$ , a slave can be selected and then later unselected with no transmission occurring. Therefore, *MODF* does not occur since a transmission was never begun.

In a slave SPI ( $MSTR = 0$ ), the *MODF* bit generates an SPI receiver/error CPU interrupt request if the *ERRIE* bit is set. The *MODF* bit does not clear the *SPE* bit or reset the SPI in any way. Software can abort the SPI transmission by clearing the *SPE* bit of the slave.

**NOTE:** A logic 1 voltage on the  $\overline{SS}$  pin of a slave SPI puts the MISO pin in a high impedance state. Also, the slave SPI ignores all incoming *SPSCK* clocks, even if it was already in the middle of a transmission.

To clear the *MODF* flag, read the *SPSCR* with the *MODF* bit set and then write to the *SPCR* register. This entire clearing mechanism must occur with no *MODF* condition existing or else the flag is not cleared.

## 14.9 Interrupts

Four SPI status flags can be enabled to generate CPU interrupt requests.

**Table 14-2. SPI Interrupts**

Flag	Request
SPTIE Transmitter empty	SPI transmitter CPU interrupt request ( $DMAS = 0$ , $SPTIE = 1$ , $SPE = 1$ )
SPRIF Receiver full	SPI receiver CPU interrupt request ( $DMAS = 0$ , $SPRIF = 1$ )
OVRIF Overflow	SPI receiver/error interrupt request ( $ERRIE = 1$ )
MODF Mode fault	SPI receiver/error interrupt request ( $ERRIE = 1$ )



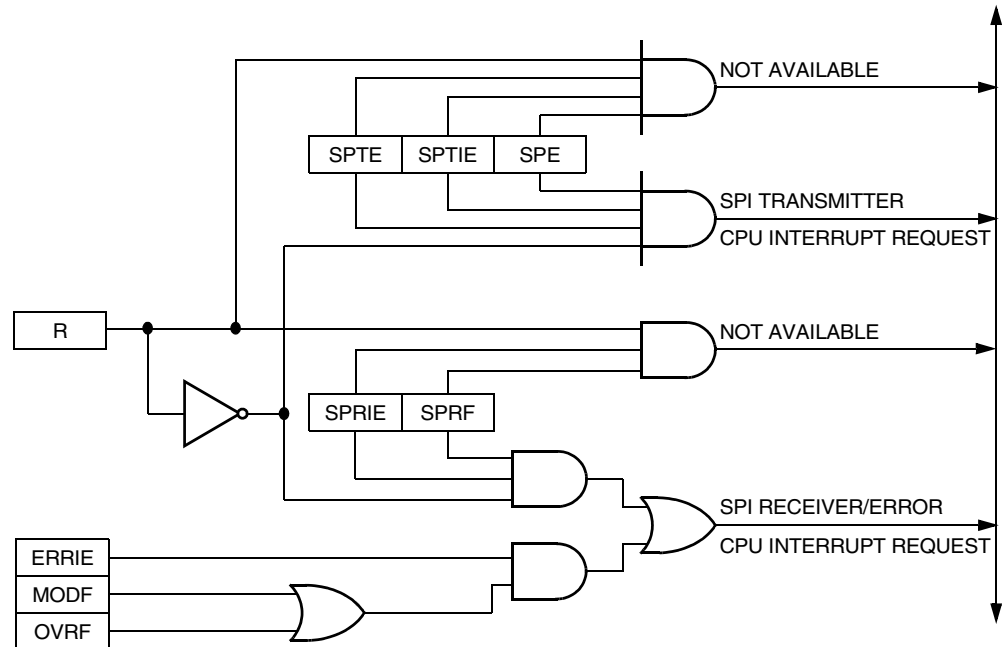
Reading the SPI status and control register with SPRF set and then reading the receive data register clears SPRF. The clearing mechanism for the SPTE flag is always just a write to the transmit data register.

The SPI transmitter interrupt enable bit (SPTIE) enables the SPTE flag to generate transmitter CPU interrupt requests, provided that the SPI is enabled (SPE = 1).

The SPI receiver interrupt enable bit (SPRIE) enables the SPRF bit to generate receiver CPU interrupt requests, regardless of the state of the SPE bit. (See [Figure 14-11.](#))

The error interrupt enable bit (ERRIE) enables both the MODF and OVRF bits to generate a receiver/error CPU interrupt request.

The mode fault enable bit (MODFEN) can prevent the MODF flag from being set so that only the OVRF bit is enabled by the ERRIE bit to generate receiver/error CPU interrupt requests.



**Figure 14-11. SPI Interrupt Request Generation**

The following sources in the SPI status and control register can generate CPU interrupt requests:

- SPI receiver full bit (SPRF) — The SPRF bit becomes set every time a byte transfers from the shift register to the receive data register. If the SPI receiver interrupt enable bit, SPRIE, is also set, SPRF generates an SPI receiver/error CPU interrupt request.
- SPI transmitter empty (SPTE) — The SPTE bit becomes set every time a byte transfers from the transmit data register to the shift register. If the SPI transmit interrupt enable bit, SPTIE, is also set, SPTE generates an SPTE CPU interrupt request.

## 14.10 Resetting the SPI

Any system reset completely resets the SPI. Partial resets occur whenever the SPI enable bit (SPE) is low. Whenever SPE is low, the following occurs:

- The SPTE flag is set.
- Any transmission currently in progress is aborted.
- The shift register is cleared.
- The SPI state counter is cleared, making it ready for a new complete transmission.
- All the SPI port logic is defaulted back to being general-purpose I/O.

These items are reset only by a system reset:

- All control bits in the SPCR register
- All control bits in the SPSCR register (MODFEN, ERRIE, SPR1, and SPR0)
- The status flags SPRF, OVRF, and MODF

By not resetting the control bits when SPE is low, the user can clear SPE between transmissions without having to set all control bits again when SPE is set back high for the next transmission.

By not resetting the SPRF, OVRF, and MODF flags, the user can still service these interrupts after the SPI has been disabled. The user can disable the SPI by writing 0 to the SPE bit. The SPI can also be disabled by a mode fault occurring in an SPI that was configured as a master with the MODFEN bit set.

## 14.11 Low-Power Modes

The WAIT and STOP instructions put the MCU in low power-consumption standby modes.

### 14.11.1 Wait Mode

The SPI module remains active after the execution of a WAIT instruction. In wait mode the SPI module registers are not accessible by the CPU. Any enabled CPU interrupt request from the SPI module can bring the MCU out of wait mode.

If SPI module functions are not required during wait mode, reduce power consumption by disabling the SPI module before executing the WAIT instruction.

To exit wait mode when an overflow condition occurs, enable the OVRF bit to generate CPU interrupt requests by setting the error interrupt enable bit (ERRIE). (See [14.9 Interrupts](#).)

### 14.11.2 Stop Mode

The SPI module is inactive after the execution of a STOP instruction. The STOP instruction does not affect register conditions. SPI operation resumes after an external interrupt. If stop mode is exited by reset, any transfer in progress is aborted, and the SPI is reset.

## 14.12 SPI During Break Interrupts

The system integration module (SIM) controls whether status bits in other modules can be cleared during the break state. The BCFE bit in the SIM break flag control register (SBFCR) enables software to clear status bits during the break state. (See [Section 9. System Integration Module \(SIM\)](#).)

To allow software to clear status bits during a break interrupt, write a logic 1 to the BCFE bit. If a status bit is cleared during the break state, it remains cleared when the MCU exits the break state.

To protect status bits during the break state, write a logic 0 to the BCFE bit. With BCFE at logic 0 (its default state), software can read and write I/O registers during the break state without affecting status bits. Some status bits have a 2-step read/write clearing procedure. If software does the first step on such a bit before the break, the bit cannot change during the break state as long as BCFE is at logic 0. After the break, doing the second step clears the status bit.

Since the SPTE bit cannot be cleared during a break with the BCFE bit cleared, a write to the transmit data register in break mode does not initiate a transmission nor is this data transferred into the shift register. Therefore, a write to the SPDR in break mode with the BCFE bit cleared has no effect.

## 14.13 I/O Signals

The SPI module has five I/O pins and shares four of them with a parallel I/O port. They are:

- MISO — Data received
- MOSI — Data transmitted
- SPCK — Serial clock
- $\overline{SS}$  — Slave select
- CGND — Clock ground (internally connected to  $V_{SS}$ )

The SPI has limited inter-integrated circuit (I<sup>2</sup>C) capability (requiring software support) as a master in a single-master environment. To communicate with I<sup>2</sup>C peripherals, MOSI becomes an open-drain output when the SPWOM bit in the SPI control register is set. In I<sup>2</sup>C communication, the MOSI and MISO pins are connected to a bidirectional pin from the I<sup>2</sup>C peripheral and through a pullup resistor to V<sub>DD</sub>.

#### 14.13.1 MISO (Master In/Slave Out)

MISO is one of the two SPI module pins that transmits serial data. In full duplex operation, the MISO pin of the master SPI module is connected to the MISO pin of the slave SPI module. The master SPI simultaneously receives data on its MISO pin and transmits data from its MOSI pin.

Slave output data on the MISO pin is enabled only when the SPI is configured as a slave. The SPI is configured as a slave when its SPMSTR bit is logic 0 and its  $\overline{SS}$  pin is at logic 0. To support a multiple-slave system, a logic 1 on the  $\overline{SS}$  pin puts the MISO pin in a high-impedance state.

When enabled, the SPI controls data direction of the MISO pin regardless of the state of the data direction register of the shared I/O port.

#### 14.13.2 MOSI (Master Out/Slave In)

MOSI is one of the two SPI module pins that transmits serial data. In full-duplex operation, the MOSI pin of the master SPI module is connected to the MOSI pin of the slave SPI module. The master SPI simultaneously transmits data from its MOSI pin and receives data on its MISO pin.

When enabled, the SPI controls data direction of the MOSI pin regardless of the state of the data direction register of the shared I/O port.

14.13.3 SPCK (Serial Clock)

The serial clock synchronizes data transmission between master and slave devices. In a master MCU, the SPCK pin is the clock output. In a slave MCU, the SPCK pin is the clock input. In full-duplex operation, the master and slave MCUs exchange a byte of data in eight serial clock cycles.

When enabled, the SPI controls data direction of the SPCK pin regardless of the state of the data direction register of the shared I/O port.

14.13.4  $\overline{SS}$  (Slave Select)

The  $\overline{SS}$  pin has various functions depending on the current state of the SPI. For an SPI configured as a slave, the  $\overline{SS}$  is used to select a slave. For CPHA = 0, the  $\overline{SS}$  is used to define the start of a transmission. (See [14.6 Transmission Formats](#).) Since it is used to indicate the start of a transmission, the  $\overline{SS}$  must be toggled high and low between each byte transmitted for the CPHA = 0 format. However, it can remain low between transmissions for the CPHA = 1 format. See [Figure 14-12](#).

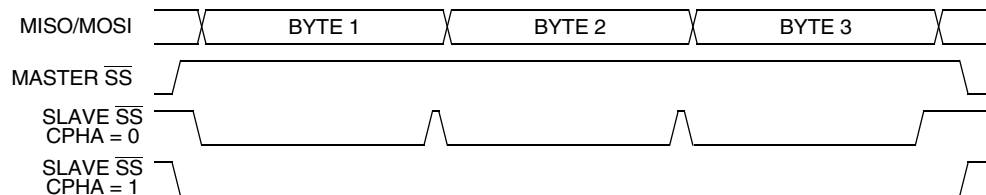


Figure 14-12. CPHA/ $\overline{SS}$  Timing

When an SPI is configured as a slave, the  $\overline{SS}$  pin is always configured as an input. It cannot be used as a general-purpose I/O regardless of the state of the MODFEN control bit. However, the MODFEN bit can still prevent the state of the  $\overline{SS}$  from creating a MODF error. (See [14.14.2 SPI Status and Control Register](#).)

**NOTE:** A logic 1 voltage on the  $\overline{SS}$  pin of a slave SPI puts the MISO pin in a high-impedance state. The slave SPI ignores all incoming SPCK clocks, even if it was already in the middle of a transmission.

When an SPI is configured as a master, the  $\overline{SS}$  input can be used in conjunction with the MODF flag to prevent multiple masters from driving MOSI and SPSCCK. (See [14.8.2 Mode Fault Error](#).) For the state of the  $\overline{SS}$  pin to set the MODF flag, the MODFEN bit in the SPSCCK register must be set. If the MODFEN bit is low for an SPI master, the  $\overline{SS}$  pin can be used as a general-purpose I/O under the control of the data direction register of the shared I/O port. With MODFEN high, it is an input-only pin to the SPI regardless of the state of the data direction register of the shared I/O port.

The CPU can always read the state of the  $\overline{SS}$  pin by configuring the appropriate pin as an input and reading the port data register. (See [Table 14-3](#).)

**Table 14-3. SPI Configuration**

SPE	SPMSTR	MODFEN	SPI Configuration	State of $\overline{SS}$ Logic
0	X <sup>(1)</sup>	X	Not enabled	General-purpose I/O; $\overline{SS}$ ignored by SPI
1	0	X	Slave	Input-only to SPI
1	1	0	Master without MODF	General-purpose I/O; $\overline{SS}$ ignored by SPI
1	1	1	Master with MODF	Input-only to SPI

Note 1. X = Don't care

### 14.13.5 CGND (Clock Ground)

CGND is the ground return for the serial clock pin, SPSCCK, and the ground for the port output buffers. It is internally connected to  $V_{SS}$  as shown in [Table 14-1](#).

### 14.14 I/O Registers

Three registers control and monitor SPI operation:

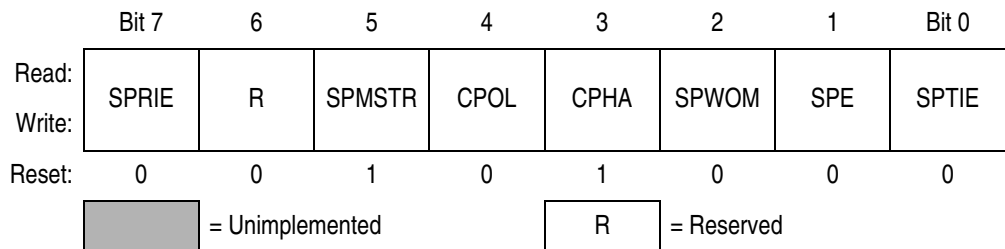
- SPI control register (SPCR)
- SPI status and control register (SPSCR)
- SPI data register (SPDR)

#### 14.14.1 SPI Control Register

The SPI control register:

- Enables SPI module interrupt requests
- Configures the SPI module as master or slave
- Selects serial clock polarity and phase
- Configures the SPSCCK, MOSI, and MISO pins as open-drain outputs
- Enables the SPI module

Address: \$0010



**Figure 14-13. SPI Control Register (SPCR)**

#### SPRIE — SPI Receiver Interrupt Enable Bit

This read/write bit enables CPU interrupt requests generated by the SPRF bit. The SPRF bit is set when a byte transfers from the shift register to the receive data register. Reset clears the SPRIE bit.

- 1 = SPRF CPU interrupt requests enabled
- 0 = SPRF CPU interrupt requests disabled



**SPMSTR — SPI Master Bit**

This read/write bit selects master mode operation or slave mode operation. Reset sets the SPMSTR bit.

- 1 = Master mode
- 0 = Slave mode

**CPOL — Clock Polarity Bit**

This read/write bit determines the logic state of the SPSCCK pin between transmissions. (See [Figure 14-4](#) and [Figure 14-6](#).) To transmit data between SPI modules, the SPI modules must have identical CPOL values. Reset clears the CPOL bit.

**CPHA — Clock Phase Bit**

This read/write bit controls the timing relationship between the serial clock and SPI data. (See [Figure 14-4](#) and [Figure 14-6](#).) To transmit data between SPI modules, the SPI modules must have identical CPHA values. When CPHA = 0, the  $\overline{SS}$  pin of the slave SPI module must be set to logic 1 between bytes. (See [Figure 14-12](#).) Reset sets the CPHA bit.

**SPWOM — SPI Wired-OR Mode Bit**

This read/write bit disables the pullup devices on pins SPSCCK, MOSI, and MISO so that those pins become open-drain outputs.

- 1 = Wired-OR SPSCCK, MOSI, and MISO pins
- 0 = Normal push-pull SPSCCK, MOSI, and MISO pins

**SPE — SPI Enable**

This read/write bit enables the SPI module. Clearing SPE causes a partial reset of the SPI. (See [14.10 Resetting the SPI](#).) Reset clears the SPE bit.

- 1 = SPI module enabled
- 0 = SPI module disabled

**SPTIE— SPI Transmit Interrupt Enable**

This read/write bit enables CPU interrupt requests generated by the SPTIE bit. SPTIE is set when a byte transfers from the transmit data register to the shift register. Reset clears the SPTIE bit.

- 1 = SPTIE CPU interrupt requests enabled
- 0 = SPTIE CPU interrupt requests disabled

14.14.2 SPI Status and Control Register

The SPI status and control register contains flags to signal these conditions:

- Receive data register full
- Failure to clear SPRF bit before next byte is received (overflow error)
- Inconsistent logic level on  $\overline{SS}$  pin (mode fault error)
- Transmit data register empty

The SPI status and control register also contains bits that perform these functions:

- Enable error interrupts
- Enable mode fault error detection
- Select master SPI baud rate

Address: \$0011

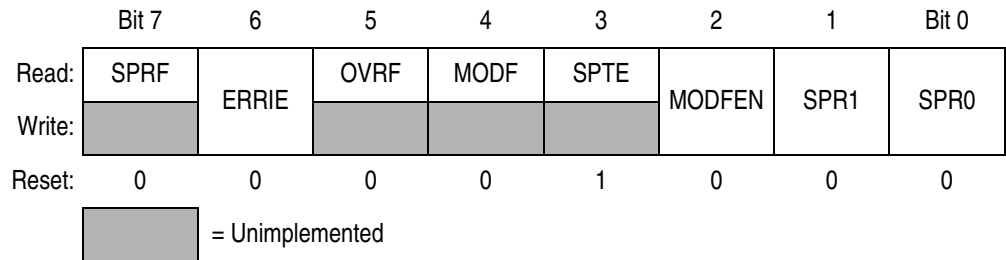


Figure 14-14. SPI Status and Control Register (SPSCR)

SPRF — SPI Receiver Full Bit

This clearable, read-only flag is set each time a byte transfers from the shift register to the receive data register. SPRF generates a CPU interrupt request if the SPRIE bit in the SPI control register is set also.

During an SPRF CPU interrupt, the CPU clears SPRF by reading the SPI status and control register with SPRF set and then reading the SPI data register. Reset clears the SPRF bit.

- 1 = Receive data register full
- 0 = Receive data register not full

**ERRIE — Error Interrupt Enable Bit**

This read/write bit enables the MODF and OVRF bits to generate CPU interrupt requests. Reset clears the ERRIE bit.

- 1 = MODF and OVRF can generate CPU interrupt requests
- 0 = MODF and OVRF cannot generate CPU interrupt requests

**OVRF — Overflow Bit**

This clearable, read-only flag is set if software does not read the byte in the receive data register before the next full byte enters the shift register. In an overflow condition, the byte already in the receive data register is unaffected, and the byte that shifted in last is lost. Clear the OVRF bit by reading the SPI status and control register with OVRF set and then reading the receive data register. Reset clears the OVRF bit.

- 1 = Overflow
- 0 = No overflow

**MODF — Mode Fault Bit**

This clearable, read-only flag is set in a slave SPI if the  $\overline{SS}$  pin goes high during a transmission with the MODFEN bit set. In a master SPI, the MODF flag is set if the  $\overline{SS}$  pin goes low at any time with the MODFEN bit set. Clear the MODF bit by reading the SPI status and control register (SPSCR) with MODF set and then writing to the SPI control register (SPCR). Reset clears the MODF bit.

- 1 =  $\overline{SS}$  pin at inappropriate logic level
- 0 =  $\overline{SS}$  pin at appropriate logic level

**SPTE — SPI Transmitter Empty Bit**

This clearable, read-only flag is set each time the transmit data register transfers a byte into the shift register. SPTE generates an SPTE CPU interrupt request if the SPTIE bit in the SPI control register is set also.

**NOTE:** *Do not write to the SPI data register unless the SPTE bit is high.*

During an SPTE CPU interrupt, the CPU clears the SPTE bit by writing to the transmit data register.

Reset sets the SPTE bit.

- 1 = Transmit data register empty
- 0 = Transmit data register not empty

**MODFEN — Mode Fault Enable Bit**

This read/write bit, when set to 1, allows the MODF flag to be set. If the MODF flag is set, clearing the MODFEN does not clear the MODF flag. If the SPI is enabled as a master and the MODFEN bit is low, then the  $\overline{SS}$  pin is available as a general-purpose I/O.

If the MODFEN bit is set, then this pin is not available as a general-purpose I/O. When the SPI is enabled as a slave, the  $\overline{SS}$  pin is not available as a general-purpose I/O regardless of the value of MODFEN. (See [14.13.4 SS \(Slave Select\)](#).)

If the MODFEN bit is low, the level of the  $\overline{SS}$  pin does not affect the operation of an enabled SPI configured as a master. For an enabled SPI configured as a slave, having MODFEN low only prevents the MODF flag from being set. It does not affect any other part of SPI operation. (See [14.8.2 Mode Fault Error](#).)

**SPR1 and SPR0 — SPI Baud Rate Select Bits**

In master mode, these read/write bits select one of four baud rates as shown in [Table 14-4](#). SPR1 and SPR0 have no effect in slave mode. Reset clears SPR1 and SPR0.

**Table 14-4. SPI Master Baud Rate Selection**

SPR1 and SPR0	Baud Rate Divisor (BD)
00	2
01	8
10	32
11	128

Use this formula to calculate the SPI baud rate:

$$\text{Baud rate} = \frac{\text{CGMOUT}}{2 \times \text{BD}}$$

where:

CGMOUT = base clock output of the clock generator module (CGM)

BD = baud rate divisor

14.14.3 SPI Data Register

The SPI data register consists of the read-only receive data register and the write-only transmit data register. Writing to the SPI data register writes data into the transmit data register. Reading the SPI data register reads data from the receive data register. The transmit data and receive data registers are separate registers that can contain different values. (See [Figure 14-2](#).)

Address: \$0012

	Bit 7	6	5	4	3	2	1	Bit 0
Read:	R7	R6	R5	R4	R3	R2	R1	R0
Write:	T7	T6	T5	T4	T3	T2	T1	T0
Reset:	Unaffected by reset							

**Figure 14-15. SPI Data Register (SPDR)**

R7–R0/T7–T0 — Receive/Transmit Data Bits

**NOTE:** Do not use read-modify-write instructions on the SPI data register since the register read is not the same as the register written.



## Section 15. Multi-Master IIC Interface (MMIIC)

### 15.1 Contents

15.2	Introduction . . . . .	319
15.3	Features . . . . .	320
15.4	I/O Pins . . . . .	320
15.5	Multi-Master IIC Registers . . . . .	321
15.5.1	Multi-Master IIC Address Register (MMADR) . . . . .	321
15.5.2	Multi-Master IIC Control Register (MMCR) . . . . .	323
15.5.3	Multi-Master IIC Master Control Register (MIMCR) . . . . .	324
15.5.4	Multi-Master IIC Status Register (MMSR) . . . . .	326
15.5.5	Multi-Master IIC Data Transmit Register (MMDTR) . . . . .	328
15.5.6	Multi-Master IIC Data Receive Register (MMDRR) . . . . .	329
15.6	Programming Considerations . . . . .	330

### 15.2 Introduction

This Multi-master IIC (MMIIC) Interface is designed for internal serial communication between the MCU and other IIC devices. A hardware circuit generates "start" and "stop" signal, while byte by byte data transfer is interrupt driven by the software algorithm. Therefore, it can greatly help the software in dealing with other devices to have higher system efficiency in a typical digital monitor system.

This module not only can be applied in internal communications, but can also be used as a typical command reception serial bus for factory setup and alignment purposes. It also provides the flexibility of hooking additional devices to an existing system for future expansion without adding extra hardware.

Multi-Master IIC Interface (MMIIC)

This Multi-master IIC module uses the SCL clock line and the SDA data line to communicate with external DDC host or IIC interface. These two pins are shared with port pins PTD6/KBI6 and PTD7/KBI7 respectively. The outputs of SCL and SDA pins are open-drain type — no clamping diode is connected between the pin and internal  $V_{DD}$ . The maximum data rate typically is 750k-bps. The maximum communication length and the number of devices that can be connected are limited by a maximum bus capacitance of 400pF.

15.3 Features

- Compatibility with multi-master IIC bus standard
- Software controllable acknowledge bit generation
- Interrupt driven byte by byte data transfer
- Calling address identification interrupt
- Auto detection of R/W bit and switching of transmit or receive mode
- Detection of START, repeated START, and STOP signals
- Auto generation of START and STOP condition in master mode
- Arbitration loss detection and No-ACK awareness in master mode
- 8 selectable baud rate master clocks
- Automatic recognition of the received acknowledge bit

15.4 I/O Pins

The MMIIC module uses two I/O pins, shared with standard port I/O pins. The full name of the MMIIC I/O pins are listed in [Table 15-1](#). The generic pin name appear in the text that follows.

Table 15-1. Pin Name Conventions

MMIIC Generic Pin Names:	Full MCU Pin Names:	Pin Selected for IIC Function By:
SDA	PTD7/KBI7/SDA <sup>(1)</sup>	MMEN bit in MMCR (\$006C)
SCL	PTD6/KBI6/SCL <sup>(1)</sup>	MMEN bit in MMCR (\$006C)

Notes:

1. Do not enable the MMIIC function if the pin is used for KBI.



Addr.	Register Name		Bit 7	6	5	4	3	2	1	Bit 0
\$006A	Multi-Master IIC Master Control Register (MIMCR)	Read:	MMALIF	MMNAKIF	MMBB	MMAST	MMRW	MMBR2	MMBR1	MMBR0
		Write:	0	0						
		Reset:	0	0	0	0	0	0	0	0
\$006B	Multi-Master IIC Address Register (MMADR)	Read:	MMAD7	MMAD6	MMAD5	MMAD4	MMAD3	MMAD2	MMAD1	MMEXTAD
		Write:								
		Reset:	1	0	1	0	0	0	0	0
\$006C	Multi-Master IIC Control Register (MMCR)	Read:	MMEN	MMIEN	0	0	MMTXAK	REPSEN	0	0
		Write:								
		Reset:	0	0	0	0	0	0	0	0
\$006D	Multi-Master IIC Status Register (MMSR)	Read:	MMRXIF	MMTXIF	MMATCH	MMSRW	MMRXAK	0	MMTXBE	MMRXBF
		Write:	0	0						
		Reset:	0	0	0	0	1	0	1	0
\$006E	Multi-Master IIC Data Transmit Register (MMDTR)	Read:	MMTD7	MMTD6	MMTD5	MMTD4	MMTD3	MMTD2	MMTD1	MMTD0
		Write:								
		Reset:	1	1	1	1	1	1	1	1
\$006F	Multi-Master IIC Data Receive Register (MMDRR)	Read:	MMRD7	MMRD6	MMRD5	MMRD4	MMRD3	MMRD2	MMRD1	MMRD0
		Write:								
		Reset:	0	0	0	0	0	0	0	0

= Unimplemented

**Figure 15-1. MMIIC I/O Register Summary**

## 15.5 Multi-Master IIC Registers

Six registers are associated with the Multi-master IIC module, they are outlined in the following sections.

### 15.5.1 Multi-Master IIC Address Register (MMADR)

Address: \$006B

	Bit 7	6	5	4	3	2	1	Bit 0
Read:	MMAD7	MMAD6	MMAD5	MMAD4	MMAD3	MMAD2	MMAD1	MMEXTAD
Write:								
Reset:	1	0	1	0	0	0	0	0

**Figure 15-2. Multi-Master IIC Address Register (MMADR)**

MMAD[7:1] — Multi-Master Address

These seven bits represent the MMIIC interface’s own specific slave address when in slave mode, and the calling address when in master mode. Software must update MMAD[7:1] as the calling address while entering master mode and restore its own slave address after master mode is relinquished. This register is cleared as \$A0 upon reset.

MMEXTAD — Multi-Master Expanded Address

This bit is set to expand the address of the MMIIC in slave mode. When set, the MMIIC will acknowledge the following addresses from a calling master: \$MMAD[7:1], 0000000, and 0001 100.

Reset clears this bit.

1 = MMIIC responds to the following calling addresses:

\$MMAD[7:1], 0000000, and 0001 100.

0 = MMIIC responds to address \$MMAD[7:1]

For example, when MMADR is configured as:

MMAD7	MMAD6	MMAD5	MMAD4	MMAD3	MMAD2	MMAD1	MMEXTAD
1	1	0	1	0	1	0	1

The MMIIC module will respond to the calling address:

Bit 7	6	5	4	3	2	Bit 1
1	1	0	1	0	1	0

or the general calling address:

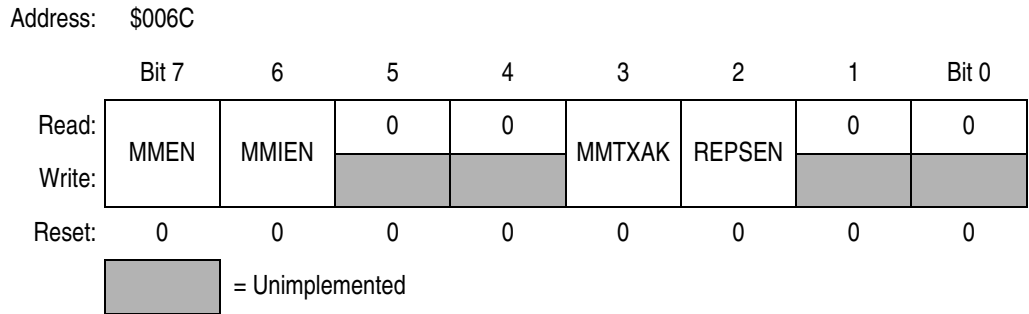
0	0	0	0	0	0	0
---	---	---	---	---	---	---

or the calling address:

0	0	0	1	1	0	0
---	---	---	---	---	---	---

**NOTE:** bit-0 of the 8-bit calling address is the MMRW bit from the calling master.

**15.5.2 Multi-Master IIC Control Register (MMCR)**



**Figure 15-3. Multi-Master IIC Control Register (MMCR)**

**MMEN — Multi-Master IIC Enable**

This bit is set to enable the Multi-master IIC module. When MMEN = 0, module is disabled and all flags will restore to its power-on default states. Reset clears this bit.

- 1 = MMIIC module enabled
- 0 = MMIIC module disabled

**MMIEN — Multi-Master IIC Interrupt Enable**

When this bit is set, the MMTXIF, MMRXIF, MMALIF, and MMNAKIF flags are enabled to generate an interrupt request to the CPU. When MMIEN is cleared, the these flags are prevented from generating an interrupt request. Reset clears this bit.

- 1 = MMTXIF, MMRXIF, MMALIF, and/or MMNAKIF bit set will generate interrupt request to CPU
- 0 = MMTXIF, MMRXIF, MMALIF, and/or MMNAKIF bit set will not generate interrupt request to CPU

**MMTXAK — Transmit Acknowledge Enable**

This bit is set to disable the MMIIC from sending out an acknowledge signal to the bus at the 9th clock bit after receiving 8 data bits. When MMTXAK is cleared, an acknowledge signal will be sent at the 9th clock bit. Reset clears this bit.

- 1 = MMIIC does not send acknowledge signals at 9th clock bit
- 0 = MMIIC sends acknowledge signal at 9th clock bit

REPSSEN — Repeated Start Enable

This bit is set to enable repeated START signal to be generated when in master mode transfer (MMAST = 1). The REPSSEN bit is cleared by hardware after the completion of repeated START signal or when the MMAST bit is cleared. Reset clears this bit.

- 1 = Repeated START signal will be generated if MMAST bit is set
- 0 = No repeated START signal will be generated

15.5.3 Multi-Master IIC Master Control Register (MIMCR)

Address: \$006A

	Bit 7	6	5	4	3	2	1	Bit 0
Read:	MMALIF	MMNAKIF	MMBB	MMAST	MMRW	MMBR2	MMBR1	MMBR0
Write:	0	0						
Reset:	0	0	0	0	0	0	0	0

= Unimplemented

Figure 15-4. Multi-Master IIC Master Control Register (MIMCR)

MMALIF — Multi-Master Arbitration Lost Interrupt Flag

This flag is set when software attempt to set MMAST but the MMBB has been set by detecting the start condition on the lines or when the MMIIC is transmitting a "1" to SDA line but detected a "0" from SDA line in master mode – an arbitration loss. This bit generates an interrupt request to the CPU if the MMIEN bit in MMCR is also set. This bit is cleared by writing "0" to it or by reset.

- 1 = Lost arbitration in master mode
- 0 = No arbitration lost

MMNAKIF — No Acknowledge Interrupt Flag

This flag is only set in master mode (MMAST = 1) when there is no acknowledge bit detected after one data byte or calling address is transferred. This flag also clears MMAST. MMNAKIF generates an interrupt request to CPU if the MMIEN bit in MMCR is also set. This bit is cleared by writing "0" to it or by reset.

- 1 = No acknowledge bit detected
- 0 = Acknowledge bit detected

## MMBB — Bus Busy Flag

This flag is set after a start condition is detected (bus busy), and is cleared when a stop condition (bus idle) is detected.

Reset clears this bit.

- 1 = Start condition detected
- 0 = Stop condition detected or MMIIC is disabled

## MMAST — Master Control Bit

This bit is set to initiate a master mode transfer. In master mode, the module generates a start condition to the SDA and SCL lines, followed by sending the calling address stored in MMADR.

When the MMAST bit is cleared by MMNAKIF set (no acknowledge) or by software, the module generates the stop condition to the lines after the current byte is transmitted.

If an arbitration loss occurs (MMALIF = 1), the module reverts to slave mode by clearing MMAST, and releasing SDA and SCL lines immediately.

This bit is cleared by writing "0" to it or by reset.

- 1 = Master mode operation
- 0 = Slave mode operation

## MMRW — Master Read/Write

This bit will be transmitted out as bit 0 of the calling address when the module sets the MMAST bit to enter master mode. The MMRW bit determines the transfer direction of the data bytes that follows. When it is "1", the module is in master receive mode. When it is "0", the module is in master transmit mode. Reset clears this bit.

- 1 = Master mode receive
- 0 = Master mode transmit

## MMBR2–MMBR0 — Baud Rate Select

These three bits select one of eight clock rates as the master clock when the module is in master mode.

Since this master clock is derived the CPU bus clock, the user program should not execute the WAIT instruction when the MMIIC module in master mode. This will cause the SDA and SCL lines to hang, as the WAIT instruction places the MCU in wait mode, with CPU clock is halted. These bits are cleared upon reset.

(See [Table 15-2 . Baud Rate Select.](#))

Table 15-2. Baud Rate Select

MMBR2	MMBR1	MMBR0	Baud Rate
0	0	0	Internal bus clock ÷ 8
0	0	1	Internal bus clock ÷ 16
0	1	0	Internal bus clock ÷ 32
0	1	1	Internal bus clock ÷ 64
1	0	0	Internal bus clock ÷ 128
1	0	1	Internal bus clock ÷ 256
1	1	0	Internal bus clock ÷ 512
1	1	1	Internal bus clock ÷ 1024

15.5.4 Multi-Master IIC Status Register (MMSR)

Address: \$006D

	Bit 7	6	5	4	3	2	1	Bit 0
Read:	MMRXIF	MMTXIF	MMATCH	MMSRW	MMRXAK	0	MMTXBE	MMRXBF
Write:	0	0						
Reset:	0	0	0	0	1	0	1	0


 = Unimplemented

Figure 15-5. Multi-Master IIC Status Register (MMSR)

MMRXIF — Multi-Master IIC Receive Interrupt Flag

This flag is set after the data receive register (MMDRR) is loaded with a new received data. Once the MMDRR is loaded with received data, no more received data can be loaded to the MMDRR register until the CPU reads the data from the MMDRR to clear MMRXBF flag.

MMRXIF generates an interrupt request to CPU if the MMIEN bit in MMCR is also set. This bit is cleared by writing "0" to it or by reset; or when the MMEN = 0.

1 = New data in data receive register (MMDRR)

0 = No data received

**MMTXIF — Multi-Master Transmit Interrupt Flag**

This flag is set when data in the data transmit register (MMDTR) is downloaded to the output circuit, and that new data can be written to the MMDTR. MMTXIF generates an interrupt request to CPU if the MMIEN bit in MMCR is also set. This bit is cleared by writing "0" to it or when the MMEN = 0.

- 1 = Data transfer completed
- 0 = Data transfer in progress

**MMATCH — Multi-Master Address Match**

This flag is set when the received data in the data receive register (MMDRR) is an calling address which matches with the address or its extended addresses (MMEXTAD=1) specified in the MMADR register.

- 1 = Received address matches MMADR
- 0 = Received address does not match

**MMSRW — Multi-Master Slave Read/Write**

This bit indicates the data direction when the module is in slave mode. It is updated after the calling address is received from a master device. MMSRW = 1 when the calling master is reading data from the module (slave transmit mode). MMSRW = 0 when the master is writing data to the module (receive mode).

- 1 = Slave mode transmit
- 0 = Slave mode receive

**MMRXAK — Multi-Master Receive Acknowledge**

When this bit is cleared, it indicates an acknowledge signal has been received after the completion of 8 data bits transmission on the bus. When MMRXAK is set, it indicates no acknowledge signal has been detected at the 9th clock; the module will release the SDA line for the master to generate "stop" or "repeated start" condition. Reset sets this bit.

- 1 = No acknowledge signal received at 9th clock bit
- 0 = Acknowledge signal received at 9th clock bit

**MMTXBE — Multi-Master Transmit Buffer Empty**

This flag indicates the status of the data transmit register (MMDTR). When the CPU writes the data to the MMDTR, the MMTXBE flag will be cleared. MMTXBE is set when MMDTR is emptied by a transfer of its data to the output circuit. Reset sets this bit.

- 1 = Data transmit register empty
- 0 = Data transmit register full

**MMRXBF — Multi-Master Receive Buffer Full**

This flag indicates the status of the data receive register (MMDRR). When the CPU reads the data from the MMDRR, the MMRXBF flag will be cleared. MMRXBF is set when MMDRR is full by a transfer of data from the input circuit to the MMDRR. Reset clears this bit.

- 1 = Data receive register full
- 0 = Data receive register empty

**15.5.5 Multi-Master IIC Data Transmit Register (MMDTR)**

Address: \$006E

	Bit 7	6	5	4	3	2	1	Bit 0
Read:	MMTD7	MMTD6	MMTD5	MMTD4	MMTD3	MMTD2	MMTD1	MMTD0
Write:								
Reset:	1	1	1	1	1	1	1	1

**Figure 15-6. Multi-Master IIC Data Transmit Register (MMDTR)**

When the MMIIC module is enabled, MMEN = 1, data written into this register depends on whether module is in master or slave mode.

In slave mode, the data in MMDTR will be transferred to the output circuit when:

- the module detects a matched calling address (MMATCH = 1), with the calling master requesting data (MMSRW = 1); or
- the previous data in the output circuit has been transmitted and the receiving master returns an acknowledge bit, indicated by a received acknowledge bit (MMRXAK = 0).



If the calling master does not return an acknowledge bit ( $MMRXAK = 1$ ), the module will release the SDA line for master to generate a "stop" or "repeated start" condition. The data in the MMDTR will not be transferred to the output circuit until the next calling from a master. The transmit buffer empty flag remains cleared ( $MMTXBE = 0$ ).

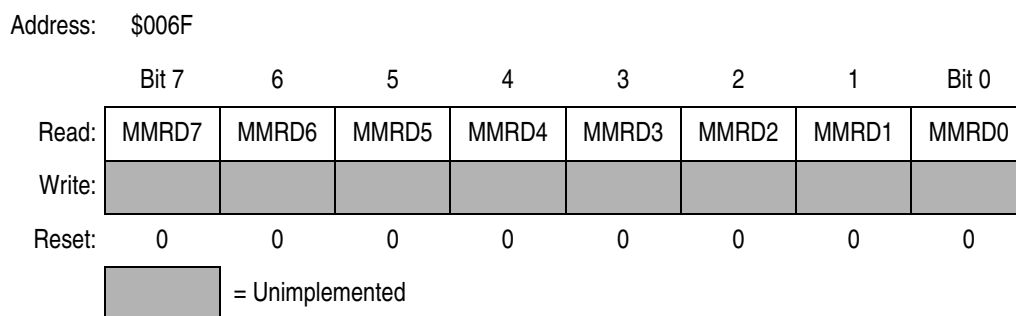
In master mode, the data in MMDTR will be transferred to the output circuit when:

- the module receives an acknowledge bit ( $MMRXAK = 0$ ), after setting master transmit mode ( $MMRW = 0$ ), and the calling address has been transmitted; or
- the previous data in the output circuit has been transmitted and the receiving slave returns an acknowledge bit, indicated by a received acknowledge bit ( $MMRXAK = 0$ ).

If the slave does not return an acknowledge bit ( $MMRXAK = 1$ ), the master will generate a "stop" or "repeated start" condition. The data in the MMDTR will not be transferred to the output circuit. The transmit buffer empty flag remains cleared ( $MMTXBE = 0$ ).

The sequence of events for slave transmit and master transmit are illustrated in [Figure 15-8](#).

## 15.5.6 Multi-Master IIC Data Receive Register (MMDRR)



**Figure 15-7. Multi-Master IIC Data Receive Register (MMDRR)**

When the MMIIC module is enabled,  $MMEN = 1$ , data in this read-only register depends on whether module is in master or slave mode.

In slave mode, the data in MMDRR is:

- the calling address from the master when the address match flag is set (MMATCH = 1); or
- the last data received when MMATCH = 0.

In master mode, the data in the MMDRR is:

- the last data received.

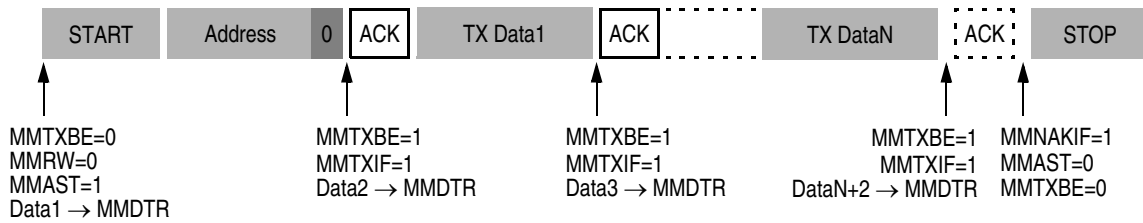
When the MMDRR is read by the CPU, the receive buffer full flag is cleared (MMRXBF = 0), and the next received data is loaded to the MMDRR. Each time when new data is loaded to the MMDRR, the MMRXIF interrupt flag is set, indicating that new data is available in MMDRR.

The sequence of events for slave receive and master receive are illustrated in [Figure 15-8](#).

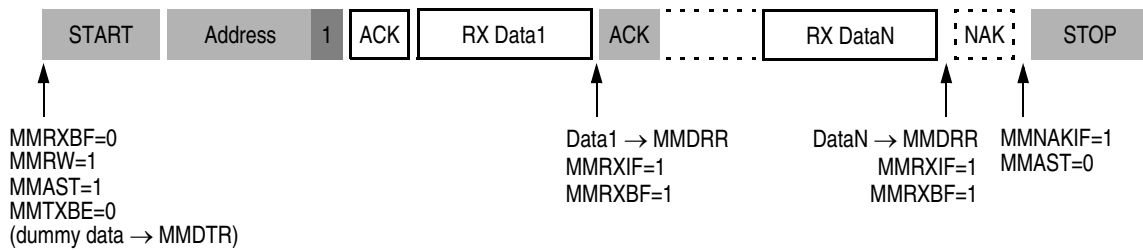
## 15.6 Programming Considerations

When the MMIIC module detects an arbitration loss in master mode, it will release both SDA and SCL lines immediately. But if there are no further STOP conditions detected, the module will hang up. Therefore, it is recommended to have time-out software to recover from such ill condition. The software can start the time-out counter by looking at the MMBB (Bus Busy) flag in the MIMCR and reset the counter on the completion of one byte transmission. If a time-out occur, software can clear the MMEN bit (disable MMIIC module) to release the bus, and hence clearing the MMBB flag. This is the only way to clear the MMBB flag by software if the module hangs up due to a no STOP condition received. The MMIIC can resume operation again by setting the MMEN bit.

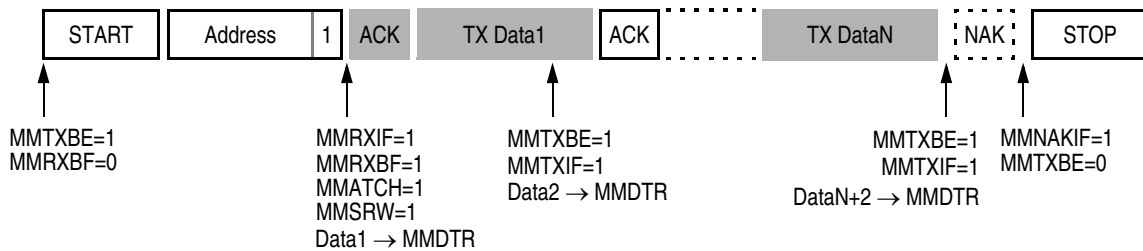
(a) Master Transmit Mode



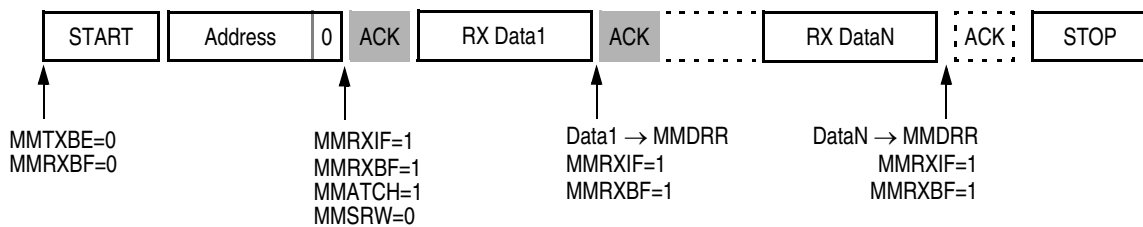
(b) Master Receive Mode



(c) Slave Transmit Mode



(d) Slave Receive Mode



■ Shaded data packets indicate transmissions by the MCU

Figure 15-8. Data Transfer Sequences for Master/Slave Transmit/Receive Modes



## Section 16. Analog-to-Digital Converter (ADC)

### 16.1 Contents

16.2	Introduction	334
16.3	Features	334
16.4	Functional Descriptions	335
16.4.1	ADC Port I/O Pins	335
16.4.2	Voltage Conversion	337
16.4.3	Conversion Time	337
16.4.4	Continuous Conversion	338
16.4.5	Result Justification	338
16.4.6	Monotonicity	339
16.5	Interrupts	340
16.6	Low-Power Modes	340
16.6.1	Wait Mode	340
16.6.2	Stop Mode	340
16.7	I/O Signals	340
16.7.1	ADC Voltage In ( $V_{ADIN}$ )	341
16.7.2	ADC Analog Power Pin ( $V_{DDA}$ )	341
16.7.3	ADC Analog Ground Pin ( $V_{SSA}$ )	341
16.7.4	ADC Voltage Reference High Pin ( $V_{REFH}$ )	341
16.7.5	ADC Voltage Reference Low Pin ( $V_{REFL}$ )	341
16.8	I/O Registers	342
16.8.1	ADC Status and Control Register	342
16.8.2	ADC Data Register	344
16.8.3	ADC Clock Control Register	346

## 16.2 Introduction

This section describes the analog-to-digital convert (ADC). The ADC is a 6-channel 10-bit linear successive approximation ADC.

## 16.3 Features

Features of the ADC module include:

- Six channels with multiplexed input
- High impedance buffered input
- Linear successive approximation with monotonicity
- 10-Bit resolution
- Single or continuous conversion
- Conversion complete flag or conversion complete interrupt
- Selectable ADC clock
- Conversion result justification
  - 8-bit truncated mode
  - Right justified mode
  - Left justified mode
  - Left justified sign mode

Addr.	Register Name		Bit 7	6	5	4	3	2	1	Bit 0
\$003C	ADC Status and Control Register (ADSCR)	Read:	COCO	AIEN	ADCO	ADCH4	ADCH3	ADCH2	ADCH1	ADCH0
		Write:								
		Reset:	0	0	0	1	1	1	1	1
\$003D	ADC Data Register High (ADRH)	Read:	ADx	ADx	ADx	ADx	ADx	ADx	ADx	ADx
		Write:	R	R	R	R	R	R	R	R
		Reset:	0	0	0	0	0	0	0	0
\$003E	ADC Data Register Low (ADRL)	Read:	ADx	ADx	ADx	ADx	ADx	ADx	ADx	ADx
		Write:	R	R	R	R	R	R	R	R
		Reset:	0	0	0	0	0	0	0	0
\$003F	ADC Clock Register (ADCLK)	Read:							0	0
		Write:	ADIV2	ADIV1	ADIV0	ADICLK	MODE1	MODE0		R
		Reset:	0	0	0	0	0	1	0	0

= Unimplemented
 R = Reserved

Figure 16-1. ADC I/O Register Summary

## 16.4 Functional Descriptions

The ADC provides six pins for sampling external sources at pins PTA4/ADC0–PTA7/ADC3 and PTB6/ADC4–PTB7/ADC5. An analog multiplexer allows the single ADC converter to select one of ten ADC channels as ADC voltage in ( $V_{ADIN}$ ).  $V_{ADIN}$  is converted by the successive approximation register-based analog-to-digital converter. When the conversion is completed, ADC places the result in the ADC data register, high and low byte (ADRH and ADRL), and sets a flag or generates an interrupt.

Figure 16-2 shows the structure of the ADC module.

### 16.4.1 ADC Port I/O Pins

PTA4–PTA7 and PTB6–PTB7 are general-purpose I/O pins that are shared with the ADC channels. The channel select bits, ADCH[4:0], define which ADC channel/port pin will be used as the input signal. The ADC overrides the port I/O logic by forcing that pin as input to the ADC. The remaining ADC channels/port pins are controlled by the port I/O

Analog-to-Digital Converter (ADC)

logic and can be used as general-purpose I/O pins. Writes to the port data register or data direction register will not have any affect on the port pin that is selected by the ADC. Read of a port pin which is in use by the ADC will return the pin condition if the corresponding DDR bit is at logic 0. If the DDR bit is at logic 1, the value in the port data latch is read.

Freescale Semiconductor, Inc.

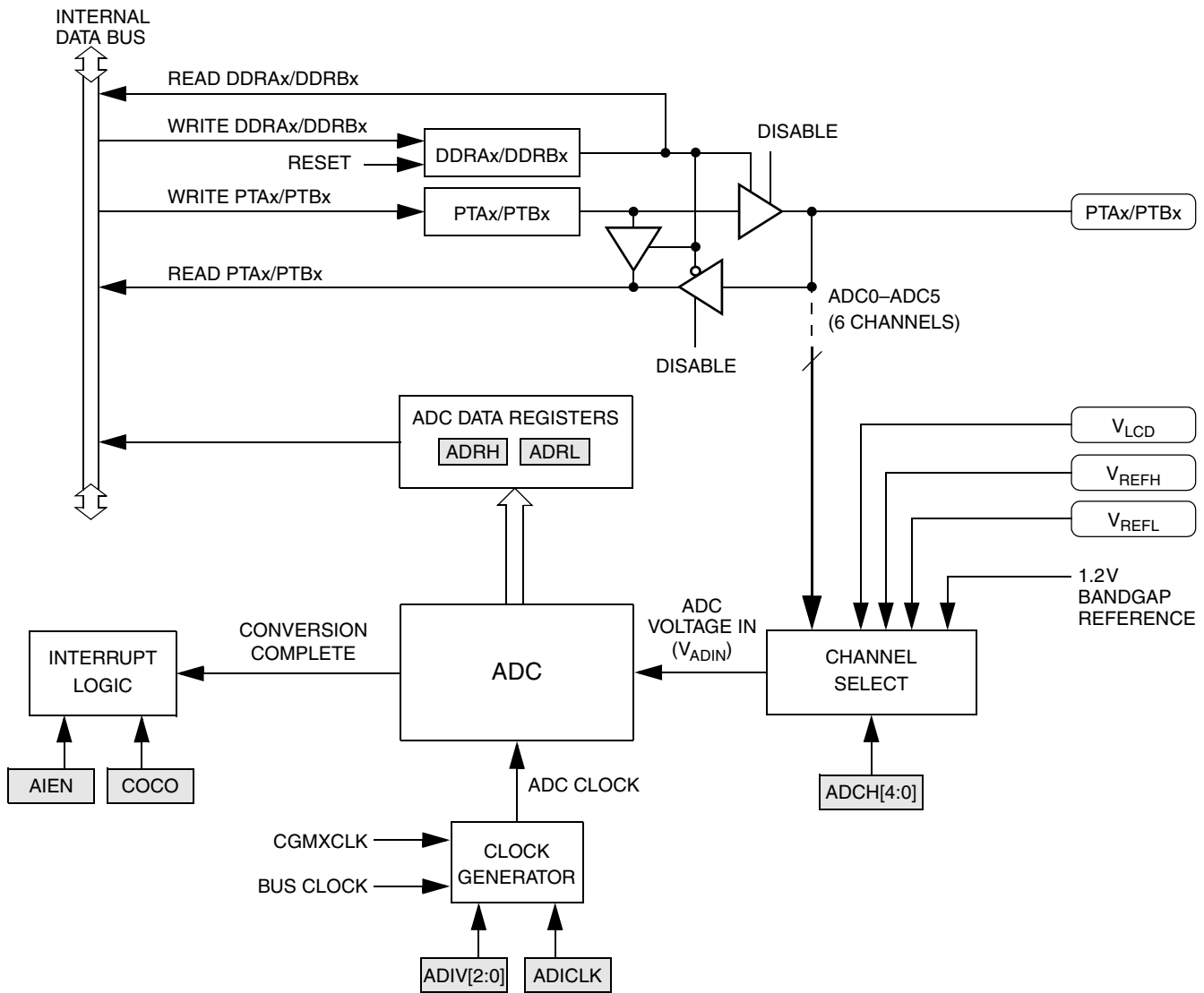


Figure 16-2. ADC Block Diagram



### 16.4.2 Voltage Conversion

When the input voltage to the ADC equals  $V_{REFH}$ , the ADC converts the signal to \$3FF (full scale). If the input voltage equals  $V_{REFL}$ , the ADC converts it to \$000. Input voltages between  $V_{REFH}$  and  $V_{REFL}$  are straight-line linear conversions. All other input voltages will result in \$3FF if greater than  $V_{REFH}$  and \$000 if less than  $V_{REFL}$ .

**NOTE:** *Input voltage should not exceed the analog supply voltages.*

### 16.4.3 Conversion Time

Conversion starts after a write to the ADSCR. A conversion is between 16 and 17 ADC clock cycles, therefore:

$$\text{Conversion time} = \frac{16 \text{ to } 17 \text{ ADC cycles}}{\text{ADC frequency}}$$

$$\text{Number of bus cycles} = \text{conversion time} \times \text{bus frequency}$$

The ADC conversion time is determined by the clock source chosen and the divide ratio selected. The clock source is either the bus clock or CGMXCLK and is selectable by the ADICLK bit located in the ADC clock control register. The divide ratio is selected by the ADIV[2:0] bits.

For example, if a 4MHz CGMXCLK is selected as the ADC input clock source, with a divide-by-2 prescale, and the bus speed is set at 8MHz:

$$\text{Conversion time} = \frac{16 \text{ to } 17 \text{ ADC cycles}}{4\text{MHz} \div 2} = 8 \text{ to } 8.5 \mu\text{s}$$

$$\text{Number of bus cycles} = 8 \mu\text{s} \times 8\text{MHz} = 64 \text{ to } 68 \text{ cycles}$$

**NOTE:** *The ADC frequency must be between  $f_{ADIC}$  minimum and  $f_{ADIC}$  maximum to meet ADC specifications. See [24.12 5V ADC Electrical Characteristics](#) and [24.13 3.3V ADC Electrical Characteristics](#).*

Since an ADC cycle may be comprised of several bus cycles (eight in the previous example) and the start of a conversion is initiated by a bus cycle write to the ADSCR, from zero to four additional bus cycles may occur before the start of the initial ADC cycle. This results in a fractional ADC cycle and is represented as the 17th cycle.

#### 16.4.4 Continuous Conversion

In the continuous conversion mode, the ADC continuously converts the selected channel, filling the ADC data register (ADRH:ADRL) with new data after each conversion. Data from the previous conversion will be overwritten whether that data has been read or not. Conversions will continue until the ADCO bit is cleared. The COCO bit is set after each conversion and can be cleared by writing to the ADC status and control register or reading of the ADRL data register.

#### 16.4.5 Result Justification

The conversion result may be formatted in four different ways.

- Left justified
- Right justified
- Left justified sign data mode
- 8-bit truncation

All four of these modes are controlled using MODE0 and MODE1 bits located in the ADC clock control register (ADCLK).

Left justification will place the eight most significant bits (MSB) in the ADC data register high (ADRH). This may be useful if the result is to be treated as an 8-bit result where the least significant two bits, located in the ADC data register low (ADRL) can be ignored. However, ADRL must be read after ADRH or else the interlocking will prevent all new conversions from being stored.

Right justification will place only the two MSBs in the corresponding ADC data register high (ADRH) and the eight LSB bits in ADC data register low (ADRL). This mode of operation typically is used when a 10-bit unsigned result is desired.

Left justified sign data mode is similar to left justified mode with one exception. The MSB of the 10-bit result, AD9 located in ADRH is complemented. This mode of operation is useful when a result, represented as a signed magnitude from mid-scale, is needed.

Finally, 8-bit truncation mode will place the eight MSBs in ADC data register low (ADRL). The two LSBs are dropped. This mode of operation is used when compatibility with 8-bit ADC designs are required. No interlocking between ADRH and ADRL is present.

**NOTE:** Quantization error is affected when only the most significant eight bits are used as a result. See [Figure 16-3](#).

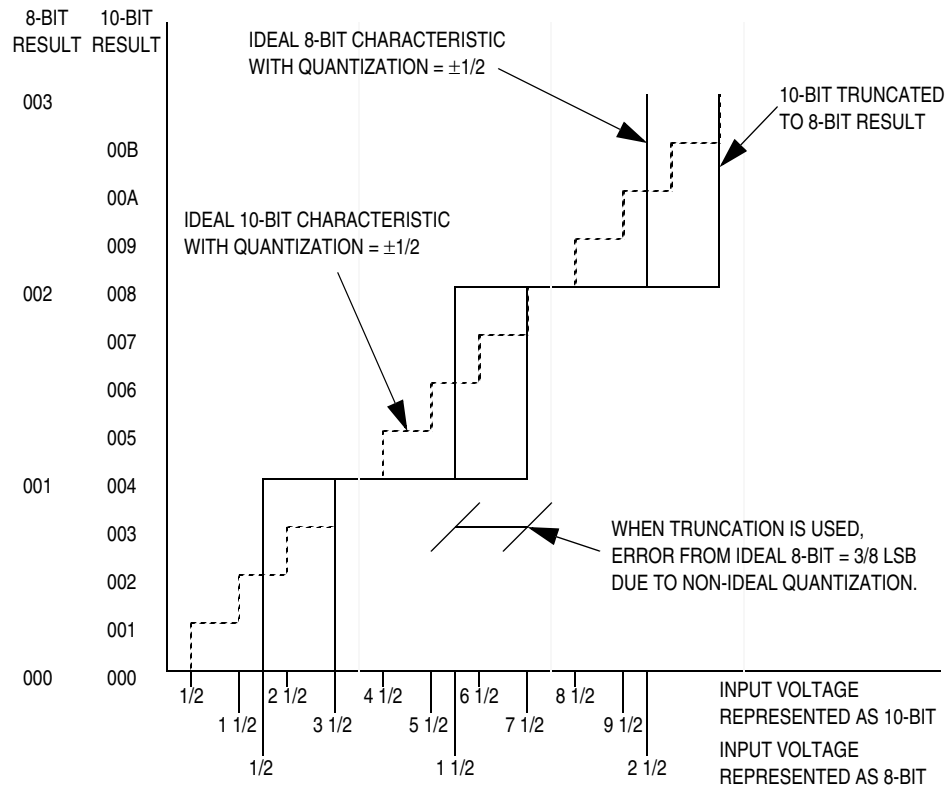


Figure 16-3. 8-Bit Truncation Mode Error

### 16.4.6 Monotonicity

The conversion process is monotonic and has no missing codes.

## 16.5 Interrupts

When the AIEN bit is set, the ADC module is capable of generating a CPU interrupt after each ADC conversion. A CPU interrupt is generated if the COCO bit is at logic 0. The COCO bit is not used as a conversion complete flag when interrupts are enabled. The interrupt vector is defined in [Table 2-1 . Vector Addresses](#).

## 16.6 Low-Power Modes

The STOP and WAIT instructions put the MCU in low power-consumption standby modes.

### 16.6.1 Wait Mode

The ADC continues normal operation in wait mode. Any enabled CPU interrupt request from the ADC can bring the MCU out of wait mode. If the ADC is not required to bring the MCU out of wait mode, power down the ADC by setting the ADCH[4:0] bits to logic 1's before executing the WAIT instruction.

### 16.6.2 Stop Mode

The ADC module is inactive after the execution of a STOP instruction. Any pending conversion is aborted. ADC conversions resume when the MCU exits stop mode. Allow one conversion cycle to stabilize the analog circuitry before attempting a new ADC conversion after exiting stop mode.

## 16.7 I/O Signals

The ADC module has ten channels, six channels are shared with port A and port B I/O pins; two channels are the ADC voltage reference inputs,  $V_{REFH}$  and  $V_{REFL}$ ; one channel is the  $V_{LCD}$  input; and one channel is the 1.2V bandgap reference voltage.

### 16.7.1 ADC Voltage In ( $V_{ADIN}$ )

$V_{ADIN}$  is the input voltage signal from one of the ten channels to the ADC module.

### 16.7.2 ADC Analog Power Pin ( $V_{DDA}$ )

The ADC analog portion uses  $V_{DDA}$  as its power pin. Connect the  $V_{DDA}$  pin to the same voltage potential as  $V_{DD}$ . External filtering may be necessary to ensure clean  $V_{DDA}$  for good results.

**NOTE:** Route  $V_{DDA}$  carefully for maximum noise immunity and place bypass capacitors as close as possible to the package.

### 16.7.3 ADC Analog Ground Pin ( $V_{SSA}$ )

The ADC analog portion uses  $V_{SSA}$  as its ground pin. Connect the  $V_{SSA}$  pin to the same voltage potential as  $V_{SS}$ .

**NOTE:** On the 64-pin and 80-pin MC68HC908LJ24,  $V_{SSA}$  is internally bonded to  $V_{SS}$ .

### 16.7.4 ADC Voltage Reference High Pin ( $V_{REFH}$ )

$V_{REFH}$  is the power supply for setting the reference voltage  $V_{REFH}$ . Connect the  $V_{REFH}$  pin to the same voltage potential as  $V_{DDA}$ . There will be a finite current associated with  $V_{REFH}$  (see [24.12 5V ADC Electrical Characteristics](#)).

**NOTE:** Route  $V_{REFH}$  carefully for maximum noise immunity and place bypass capacitors as close as possible to the package.

### 16.7.5 ADC Voltage Reference Low Pin ( $V_{REFL}$ )

$V_{REFL}$  is the lower reference supply for the ADC. Connect the  $V_{REFL}$  pin to the same voltage potential as  $V_{SSA}$ . There will be a finite current associated with  $V_{REFL}$  (see [24.12 5V ADC Electrical Characteristics](#)).

## 16.8 I/O Registers

These I/O registers control and monitor operation of the ADC:


- ADC status and control register, (ADSCR)
- ADC data register (ADRH:ADRL)
- ADC clock control register (ADCLK)

### 16.8.1 ADC Status and Control Register

This section describes the function of the ADC status and control register (ADSCR). Writing ADSCR aborts the current conversion and initiates a new conversion.

Address: \$003C

Read:	COCO	AIEN	ADCO	ADCH4	ADCH3	ADCH2	ADCH1	ADCH0
Write:								
Reset:	0	0	0	1	1	1	1	1

 = Unimplemented

**Figure 16-4. ADC Status and Control Register (ADSCR)**

#### COCO — Conversions Complete Bit

When the AIEN bit is a logic 0, the COCO is a read-only bit which is set each time a conversion is completed. This bit is cleared whenever the ADSCR is written, or whenever the ADC clock control register is written, or whenever the ADC data register low, ADRL, is read.

If the AIEN bit is logic 1, the COCO bit always read as logic 0, CPU to service the ADC interrupt will be generated at the end if an ADC conversion. Reset clears the COCO bit.

1 = Conversion completed (AIEN = 0)

0 = Conversion not completed (AIEN = 0)/CPU interrupt (AIEN=1)

#### AIEN — ADC Interrupt Enable Bit

When this bit is set, an interrupt is generated at the end of an ADC conversion. The interrupt signal is cleared when the data register, ADR0, is read or the ADSCR is written. Reset clears the AIEN bit.

1 = ADC interrupt enabled

0 = ADC interrupt disabled

## ADCO — ADC Continuous Conversion Bit

When set, the ADC will convert samples continuously and update the ADC data register at the end of each conversion. Only one conversion is allowed when this bit is cleared. Reset clears the ADCO bit.

1 = Continuous ADC conversion

0 = One ADC conversion

## ADCH[4:0] — ADC Channel Select Bits

ADCH[4:0] form a 5-bit field which is used to select one of the ADC channels when not in auto-scan mode. The five channel select bits are detailed in [Table 16-1](#).

**NOTE:** Care should be taken when using a port pin as both an analog and a digital input simultaneously to prevent switching noise from corrupting the analog signal.  
Recovery from the disabled state requires one conversion cycle to stabilize.

**Table 16-1. MUX Channel Select**

ADCH4	ADCH3	ADCH2	ADCH1	ADCH0	ADC Channel	Input Select
0	0	0	0	0	ADC0	PTA4
0	0	0	0	1	ADC1	PTA5
0	0	0	1	0	ADC2	PTA6
0	0	0	1	1	ADC3	PTA7
0	0	1	0	0	ADC4	PTB6
0	0	1	0	1	ADC5	PTB7
0	0	1	1	0	ADC6	1.2V Bandgap reference
0	0	1	1	1	ADC7	V <sub>LCD</sub>
0	1	0	0	0	ADC8	Reserved
↓	↓	↓	↓	↓	↓	
1	1	1	0	0	ADC28	
1	1	1	0	1	ADC29	V <sub>REFH</sub> (see Note 2)
1	1	1	1	0	ADC30	V <sub>REFL</sub> (see Note 2)
1	1	1	1	1	ADC powered-off	—

**NOTES:**

1. If any reserved channels are selected, the resulting ADC conversion will be unknown.
2. The voltage levels supplied from internal reference nodes as specified in the table are used to verify the operation of the ADC converter both in production test and for user applications.

Analog-to-Digital Converter (ADC)

16.8.2 ADC Data Register

The ADC data register consist of a pair of 8-bit registers: high byte (ADRH), and low byte (ADRL). This pair form a 16-bit register to store the 10-bit ADC result for the selected ADC result justification mode.

In 8-bit truncated mode, the ADRL holds the eight most significant bits (MSBs) of the 10-bit result. The ADRL is updated each time an ADC conversion completes. In 8-bit truncated mode, ADRL contains no interlocking with ADRH. (See [Figure 16-5 . ADRH and ADRL in 8-Bit Truncated Mode.](#))

Addr.	Register Name		Bit 7	6	5	4	3	2	1	Bit 0	
\$003D	ADC Data Register High (ADRH)	Read:	0	0	0	0	0	0	0	0	0
		Write:	R	R	R	R	R	R	R	R	R
		Reset:	0	0	0	0	0	0	0	0	0
\$003E	ADC Data Register Low (ADRL)	Read:	AD9	AD8	AD7	AD6	AD5	AD4	AD3	AD2	
		Write:	R	R	R	R	R	R	R	R	R
		Reset:	0	0	0	0	0	0	0	0	0

Figure 16-5. ADRH and ADRL in 8-Bit Truncated Mode

In right justified mode the ADRH holds the two MSBs, and the ADRL holds the eight least significant bits (LSBs), of the 10-bit result. ADRH and ADRL are updated each time a single channel ADC conversion completes. Reading ADRH latches the contents of ADRL. Until ADRL is read all subsequent ADC results will be lost.

(See [Figure 16-6 . ADRH and ADRL in Right Justified Mode.](#))

Addr.	Register Name		Bit 7	6	5	4	3	2	1	Bit 0	
\$003D	ADC Data Register High (ADRH)	Read:	0	0	0	0	0	0	AD9	AD8	
		Write:	R	R	R	R	R	R	R	R	R
		Reset:	0	0	0	0	0	0	0	0	0
\$003E	ADC Data Register Low (ADRL)	Read:	AD7	AD6	AD5	AD4	AD3	AD2	AD1	AD0	
		Write:	R	R	R	R	R	R	R	R	R
		Reset:	0	0	0	0	0	0	0	0	0

Figure 16-6. ADRH and ADRL in Right Justified Mode



In left justified mode the ADRH holds the eight most significant bits (MSBs), and the ADRL holds the two least significant bits (LSBs), of the 10-bit result. The ADRH and ADRL are updated each time a single channel ADC conversion completes. Reading ADRH latches the contents of ADRL. Until ADRL is read all subsequent ADC results will be lost. (See [Figure 16-7 . ADRH and ADRL in Left Justified Mode.](#))

Addr.	Register Name	Bit 7	6	5	4	3	2	1	Bit 0	
\$003D	ADC Data Register High (ADRH)	Read:	AD9	AD8	AD7	AD6	AD5	AD4	AD3	AD2
		Write:	R	R	R	R	R	R	R	R
		Reset:	0	0	0	0	0	0	0	0
\$003E	ADC Data Register Low (ADRL)	Read:	AD1	AD0	0	0	0	0	0	0
		Write:	R	R	R	R	R	R	R	R
		Reset:	0	0	0	0	0	0	0	0

**Figure 16-7. ADRH and ADRL in Left Justified Mode**

In left justified sign mode the ADRH holds the eight MSBs with the MSB complemented, and the ADRL holds the two least significant bits (LSBs), of the 10-bit result. The ADRH and ADRL are updated each time a single channel ADC conversion completes. Reading ADRH latches the contents of ADRL. Until ADRL is read all subsequent ADC results will be lost. (See [Figure 16-8 . ADRH and ADRL in Left Justified Sign Data Mode.](#))

Addr.	Register Name	Bit 7	6	5	4	3	2	1	Bit 0	
\$003D	ADC Data Register High (ADRH)	Read:	$\overline{AD9}$	AD8	AD7	AD6	AD5	AD4	AD3	AD2
		Write:	R	R	R	R	R	R	R	R
		Reset:	0	0	0	0	0	0	0	0
\$003E	ADC Data Register Low (ADRL)	Read:	AD1	AD0	0	0	0	0	0	0
		Write:	R	R	R	R	R	R	R	R
		Reset:	0	0	0	0	0	0	0	0

**Figure 16-8. ADRH and ADRL in Left Justified Sign Data Mode**

16.8.3 ADC Clock Control Register

The ADC clock control register (ADCLK) selects the clock frequency for the ADC.

Address: \$003F

Read:	ADIV2	ADIV1	ADIV0	ADICLK	MODE1	MODE0	0	0
Write:								R
Reset:	0	0	0	0	0	1	0	0

= Unimplemented
 R = Reserved

Figure 16-9. ADC Clock Control Register (ADCLK)

ADIV[2:0] — ADC Clock Prescaler Bits

ADIV2, ADIV1, and ADIV0 form a 3-bit field which selects the divide ratio used by the ADC to generate the internal ADC clock.

Table 16-2 shows the available clock configurations. The ADC clock should be set to between 32kHz and 2MHz.

Table 16-2. ADC Clock Divide Ratio

ADIV2	ADIV1	ADIV0	ADC Clock Rate
0	0	0	ADC input clock ÷ 1
0	0	1	ADC input clock ÷ 2
0	1	0	ADC input clock ÷ 4
0	1	1	ADC input clock ÷ 8
1	X	X	ADC input clock ÷ 16

X = don't care

ADICLK — ADC Input Clock Select Bit

ADICLK selects either bus clock or CGMXCLK as the input clock source to generate the internal ADC clock. Reset selects CGMXCLK as the ADC clock source.

If the external clock (CGMXCLK) is equal to or greater than 1 MHz, CGMXCLK can be used as the clock source for the ADC. If CGMXCLK is less than 1 MHz, use the PLL-generated bus clock as the clock source. As long as the internal ADC clock is at  $f_{ADIC}$ , correct operation can be guaranteed.

1 = Internal bus clock

0 = External clock, CGMXCLK

$$f_{ADIC} = \frac{\text{CGMXCLK or bus frequency}}{\text{ADIV}[2:0]}$$

**MODE1 and MODE0 — Modes of Result Justification**

MODE1 and MODE0 selects between four modes of operation. The manner in which the ADC conversion results will be placed in the ADC data registers is controlled by these modes of operation. Reset returns right-justified mode.

**Table 16-3. ADC Mode Select**

MODE1	MODE0	ADC Clock Rate
0	0	8-bit truncated mode
0	1	Right justified mode
1	0	Left justified mode
1	1	Left justified sign data mode



## Section 17. Liquid Crystal Display (LCD) Driver

### 17.1 Contents

17.2	Introduction	350
17.3	Features	350
17.4	Pin Name Conventions and I/O Register Addresses	350
17.5	Functional Description	354
17.5.1	LCD Duty	356
17.5.2	LCD Voltages ( $V_{LCD}$ , $V_{LCD1}$ , $V_{LCD2}$ , $V_{LCD3}$ )	356
17.5.3	LCD Cycle Frame	356
17.5.4	Fast Charge and Low Current	357
17.5.5	Contrast Control	358
17.6	Low-Power Modes	358
17.6.1	Wait Mode	359
17.6.2	Stop Mode	359
17.7	I/O Signals	359
17.7.1	BP0–BP3 (Backplane Drivers)	360
17.7.2	FP0–FP32 (Frontplane Drivers)	362
17.8	Seven Segment Display Connection	366
17.9	I/O Registers	369
17.9.1	LCD Control Register (LCDCR)	369
17.9.2	LCD Clock Register (LCDCLK)	371
17.9.3	LCD Data Registers (LDAT1–LDAT17)	373

## 17.2 Introduction

This section describes the liquid crystal display (LCD) driver module. The LCD driver module can drive a maximum of 33 frontplanes and 4 backplanes, depending on the LCD duty selected.

## 17.3 Features

Features of the LCD driver module include the following:

- Software programmable driver segment configurations:
  - 32 frontplanes × 4 backplanes (128 segments)
  - 33 frontplanes × 3 backplanes (99 segments)
  - 33 frontplanes × 1 backplane (33 segments)
- LCD bias voltages generated by internal resistor ladder
- Software programmable contrast control

## 17.4 Pin Name Conventions and I/O Register Addresses

Three dedicated I/O pins are for the backplanes, BP0–BP2; sixteen dedicated I/O pins are for the frontplanes, FP1–FP10 and FP27–FP32; and the sixteen frontplanes, FP11–FP26, are shared with port C and E pins. FP0 and BP3 shares the same pin and configured by the DUTY[1:0] bits in the LCD clock register.

The full names of the LCD output pins are shown in [Table 17-1](#). The generic pin names appear in the text that follows.

**Table 17-1. Pin Name Conventions**

LCD Generic Pin Name	Full MCU Pin Name	Pin Selected for LCD Function by:
FP0/BP3	FP0/BP3	—
BP0–BP2	BP0–BP2	—
FP1–FP10	FP1–FP10	—
FP11–FP18	PTE0/FP11–PTE7/FP18	PEE in CONFIG2
FP19–FP26	PTC0/FP19–PTC7/FP26	PCEL:PCEH in CONFIG2
FP27–FP32	FP27–FP32	—

# Freescale Semiconductor, Inc.

## Liquid Crystal Display (LCD) Driver Pin Name Conventions and I/O Register Addresses

Addr.	Register Name	Bit 7	6	5	4	3	2	1	Bit 0	
\$004F	LCD Clock Register (LCDCLK)	Read:	0	FCCTL1	FCCTL0	DUTY1	DUTY0	LCLK2	LCLK1	LCLK0
		Write:								
		Reset:	0	0	0	0	0	0	0	0
\$0051	LCD Control Register (LCDCR)	Read:	LCDE	0	FC	LC	LCCON3	LCCON2	LCCON1	LCCON0
		Write:								
		Reset:	0	0	0	0	0	0	0	0
\$0052	LCD Data Register 1 (LDAT1)	Read:	F1B3	F1B2	F1B1	F1B0	F0B3	F0B2	F0B1	F0B0
		Write:								
		Reset:	U	U	U	U	U	U	U	U
\$0053	LCD Data Register 2 (LDAT2)	Read:	F3B3	F3B2	F3B1	F3B0	F2B3	F2B2	F2B1	F2B0
		Write:								
		Reset:	U	U	U	U	U	U	U	U
\$0054	LCD Data Register 3 (LDAT3)	Read:	F5B3	F5B2	F5B1	F5B0	F4B3	F4B2	F4B1	F4B0
		Write:								
		Reset:	U	U	U	U	U	U	U	U
\$0055	LCD Data Register 4 (LDAT4)	Read:	F7B3	F7B2	F7B1	F7B0	F6B3	F6B2	F6B1	F6B0
		Write:								
		Reset:	U	U	U	U	U	U	U	U
\$0056	LCD Data Register 5 (LDAT5)	Read:	F9B3	F9B2	F9B1	F9B0	F8B3	F8B2	F8B1	F8B0
		Write:								
		Reset:	U	U	U	U	U	U	U	U
\$0057	LCD Data Register 6 (LDAT6)	Read:	F11B3	F11B2	F11B1	F11B0	F10B3	F10B2	F10B1	F10B0
		Write:								
		Reset:	U	U	U	U	U	U	U	U
\$0058	LCD Data Register 7 (LDAT7)	Read:	F13B3	F13B2	F13B1	F13B0	F12B3	F12B2	F12B1	F12B0
		Write:								
		Reset:	U	U	U	U	U	U	U	U
\$0059	LCD Data Register 8 (LDAT8)	Read:	F15B3	F15B2	F15B1	F15B0	F14B3	F14B2	F14B1	F14B0
		Write:								
		Reset:	U	U	U	U	U	U	U	U

U = Unaffected      = Unimplemented

**Figure 17-1. LCD I/O Register Summary**

Liquid Crystal Display (LCD) Driver

\$005A	LCD Data Register 9 (LDAT9)	Read:	F17B3	F17B2	F17B1	F17B0	F16B3	F16B2	F16B1	F16B0
		Write:								
		Reset:	U	U	U	U	U	U	U	U
\$005B	LCD Data Register 10 (LDAT10)	Read:	F19B3	F19B2	F19B1	F19B0	F18B3	F18B2	F18B1	F18B0
		Write:								
		Reset:	U	U	U	U	U	U	U	U
\$005C	LCD Data Register 11 (LDAT11)	Read:	F21B3	F21B2	F21B1	F21B0	F20B3	F20B2	F20B1	F20B0
		Write:								
		Reset:	U	U	U	U	U	U	U	U
\$005D	LCD Data Register 12 (LDAT12)	Read:	F23B3	F23B2	F23B1	F23B0	F22B3	F22B2	F22B1	F22B0
		Write:								
		Reset:	U	U	U	U	U	U	U	U
\$005E	LCD Data Register 13 (LDAT13)	Read:	F25B3	F25B2	F25B1	F25B0	F24B3	F24B2	F24B1	F24B0
		Write:								
		Reset:	U	U	U	U	U	U	U	U
\$005F	LCD Data Register 14 (LDAT14)	Read:	F27B3	F27B2	F27B1	F27B0	F26B3	F26B2	F26B1	F26B0
		Write:								
		Reset:	U	U	U	U	U	U	U	U
\$0060	LCD Data Register 15 (LDAT15)	Read:	F29B3	F29B2	F29B1	F29B0	F28B3	F28B2	F28B1	F28B0
		Write:								
		Reset:	U	U	U	U	U	U	U	U
\$0061	LCD Data Register 16 (LDAT16)	Read:	F31B3	F31B2	F31B1	F31B0	F30B3	F30B2	F30B1	F30B0
		Write:								
		Reset:	U	U	U	U	U	U	U	U
\$0062	LCD Data Register 17 (LDAT17)	Read:					F32B3	F32B2	F32B1	F32B0
		Write:								
		Reset:					U	U	U	U

U = Unaffected       = Unimplemented

Figure 17-1. LCD I/O Register Summary



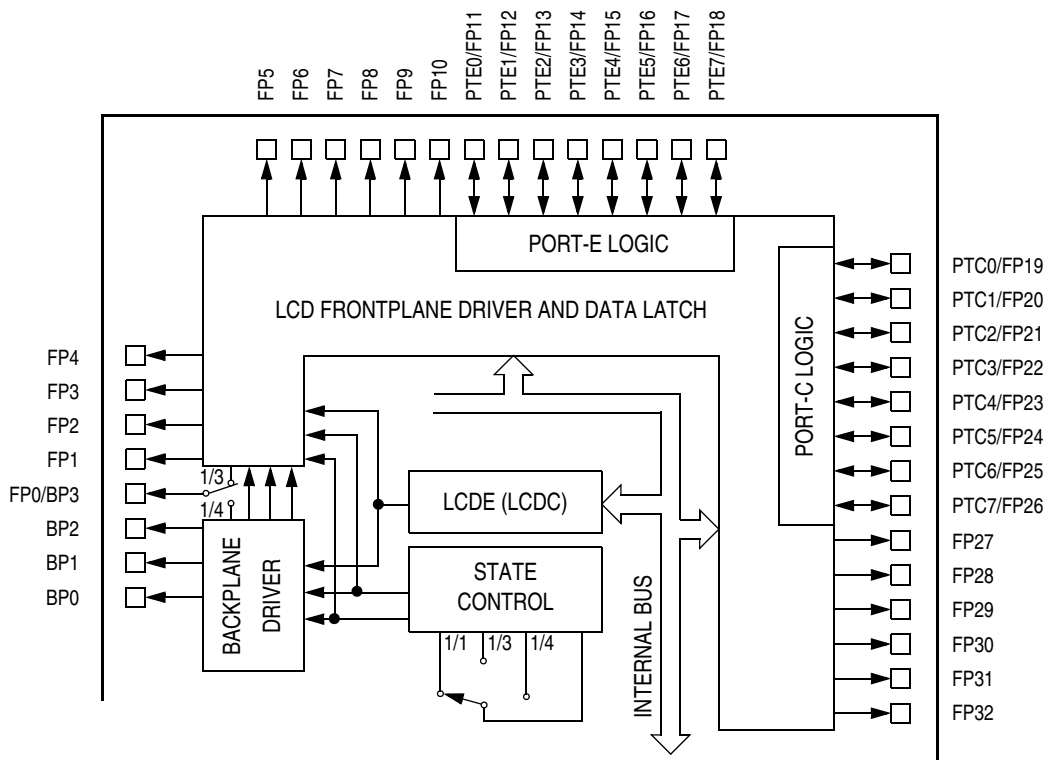
## 17.5 Functional Description

**Figure 17-2** shows a block diagram of the LCD driver module, and **Figure 17-3** shows a simplified schematic of the LCD system.

The LCD driver module uses a 1/3 biasing method. The LCD power is supplied by the  $V_{LCD}$  pin. Voltages  $V_{LCD1}$ ,  $V_{LCD2}$ , and  $V_{LCD3}$  are generated by an internal resistor ladder.

The LCD data registers, LDAT1–LDAT17, control the LCD segments' ON/OFF, with each data register controlling two frontplanes. When a logic 1 is written to a FxBx bit in the data register, the corresponding frontplane-backplane segment will turn ON. When a logic 0 is written, the the segment will turn OFF.

When the LCD driver module is disabled ( $LCDE = 0$ ), the LCD display will be OFF, all backplane and frontplane drivers have the same potential as  $V_{DD}$ . The resistor ladder is disconnected from  $V_{DD}$  to reduce power consumption.



**Figure 17-2. LCD Block Diagram**

Liquid Crystal Display (LCD) Driver

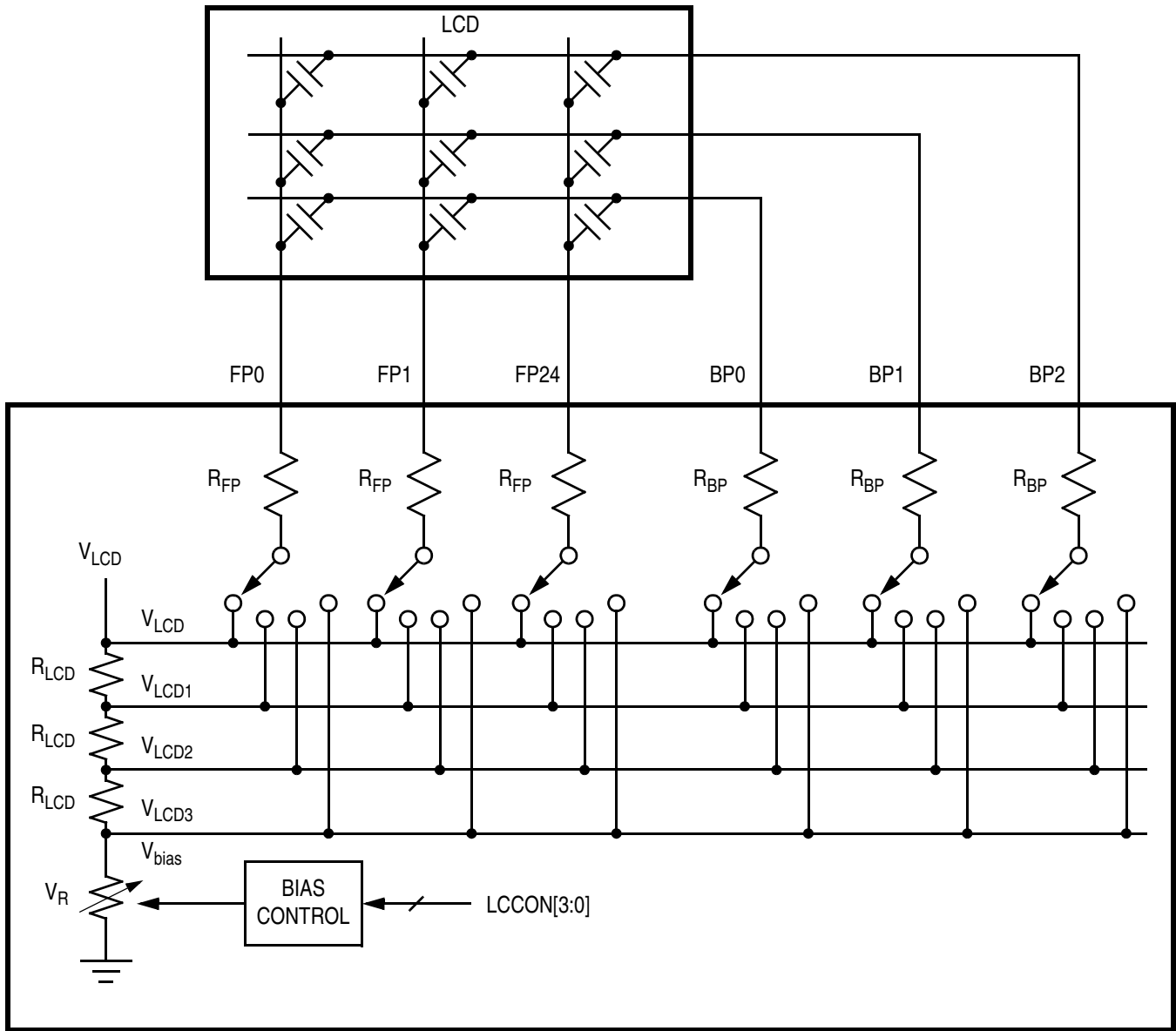


Figure 17-3. Simplified LCD Schematic (1/3 Duty, 1/3 Bias)

### 17.5.1 LCD Duty

The setting of the LCD output waveform duty is dependent on the number of backplane drivers required. Three LCD duties are available:

- Static duty — BP0 is used only
- 1/3 duty — BP0, BP1, and BP3 are used
- 1/4 duty — BP0, BP1, BP2, and BP3 are used

When the LCD driver module is enabled the backplane waveforms for the selected duty are driven out of the backplane pins. The backplane waveforms are periodic and are shown in [Figure 17-5](#), [Figure 17-6](#), and [Figure 17-7](#).

### 17.5.2 LCD Voltages ( $V_{LCD}$ , $V_{LCD1}$ , $V_{LCD2}$ , $V_{LCD3}$ )

The voltage  $V_{LCD}$  is from the  $V_{LCD}$  pin and must not exceed  $V_{DD}$ .  $V_{LCD1}$ ,  $V_{LCD2}$ , and  $V_{LCD3}$  are internal bias voltages for the LCD driver waveforms. They are derived from  $V_{LCD}$  using a resistor ladder (see [Figure 17-3](#)).

The relative potential of the LCD voltages are:

- $V_{LCD} = V_{DD}$
- $V_{LCD1} = 2/3 \times (V_{LCD} - V_{bias})$
- $V_{LCD2} = 1/3 \times (V_{LCD} - V_{bias})$
- $V_{LCD3} = V_{bias}$

The  $V_{LCD3}$  bias voltage,  $V_{bias}$ , is controlled by the LCD contrast control bits, LCCON[2:0].

### 17.5.3 LCD Cycle Frame

The LCD driver module uses the CGMXCLK (see [Section 7. Oscillator \(OSC\)](#)) as the input reference clock. This clock is divided to produce the LCD waveform base clock, LCDCLK, by configuring the LCLK[2:0] bits in the LCD clock register. The LCDCLK clocks the backplane and the frontplane output waveforms.

The LCD cycle frame is determined by the equation:

$$\text{LCD CYCLE FRAME} = \frac{1}{\text{LCD WAVEFORM BASE CLOCK} \times \text{DUTY}}$$

For example, for 1/3 duty and 256Hz waveform base clock:

$$\begin{aligned} \text{LCD CYCLE FRAME} &= \frac{1}{256 \times (1/3)} \\ &= 11.72 \text{ ms} \end{aligned}$$

#### 17.5.4 Fast Charge and Low Current

The default value for each of the bias resistors (see [Figure 17-3](#)),  $R_{\text{LCD}}$ , in the resistor ladder is approximately 37kΩ at  $V_{\text{LCD}} = 3\text{V}$ . The relatively high current drain through the 37kΩ resistor ladder may not be suitable for some LCD panel connections. Lowering this current is possible by setting the LC bit in the LCD control register, switching the  $R_{\text{LCD}}$  value to 146kΩ.

Although the lower current drain is desirable, but in some LCD panel connections, the higher current is required to drive the capacitive load of the LCD panel. In most cases, the higher current is only required when the LCD waveforms change state (the rising and falling edges in the LCD output waveforms). The fast charge option is designed to have the high current for the switching and the low current for the steady state. Setting the FC bit in the LCD control register selects the fast charge option. The  $R_{\text{LCD}}$  value is set to 37kΩ (for high current) for a fraction of time for each LCD waveform switching edge, and then back to 146kΩ for the steady state period. The duration of the fast charge time is set by configuring the FCCTL[1:0] bits in the LCD clock register, and can be LCDCLK/32, LCDCLK/64, or LCDCLK/128. [Figure 17-4](#) shows the fast charge clock relative to the BP0 waveform.

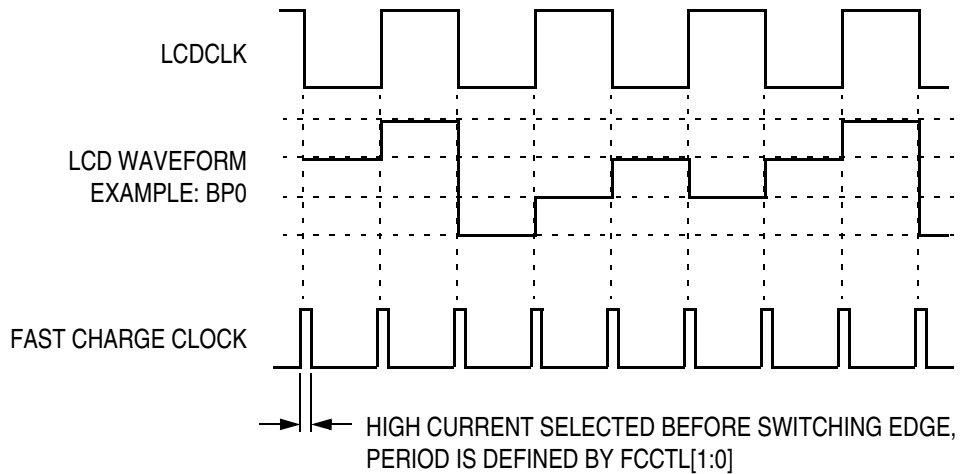


Figure 17-4. Fast Charge Timing

### 17.5.5 Contrast Control

The contrast of the connected LCD panel can be adjusted by configuring the LCCON[3:0] bits in the LCD control register. The LCCON[3:0] bits provide a 16-step contrast control, which adjusts the bias voltage in the resistor ladder for LCD voltage,  $V_{LCD3}$ . The relative voltages,  $V_{LCD1}$  and  $V_{LCD2}$ , are altered accordingly. For example, setting LCCON[3:0] = \$F, the relative panel potential voltage ( $V_{LCD} - V_{LCD3}$ ) is reduced from maximum 3.3V to approximate 2.45V.

The  $V_{LCD}$  voltage can be monitored by the ADC channel, ADC7, and then adjustments to the bias voltage by the user software to provide automatic contrast control.

### 17.6 Low-Power Modes

The STOP and WAIT instructions put the MCU in low power-consumption standby modes.

### 17.6.1 Wait Mode

The LCD driver module continues normal operation in wait mode. If the LCD is not required in wait mode, power down the LCD module by clearing the LCDE bit before executing the WAIT instruction.

### 17.6.2 Stop Mode

For continuous LCD module operation in stop mode, the oscillator stop mode enable bit (STOP\_XCLKEN in CONFIG2 register) must be set before executing the STOP instruction. When STOP\_XCLKEN is set, CGMXCLK continues to drive the LCD module.

If STOP\_XCLKEN bit is cleared, the LCD module is inactive after the execution of a STOP instruction. The STOP instruction does not affect LCD register states. LCD module operation resumes after an external interrupt. To further reduce power consumption, the LCD module should be powered-down by clearing the LCDE bit before executing the STOP instruction.

## 17.7 I/O Signals

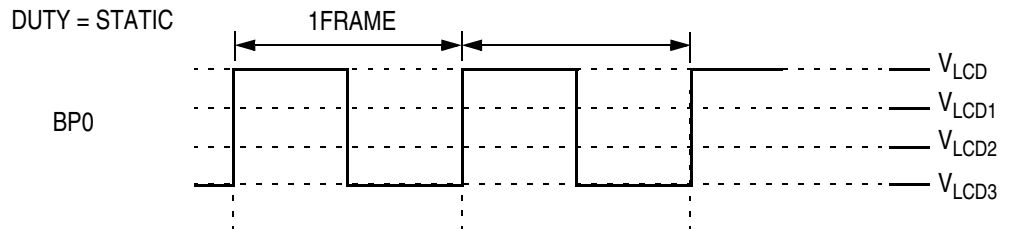
The LCD driver module has thirty-six (36) output pins and shares eight of them with port C I/O pins and eight with port E I/O pins.

- FP0/BP3 (multiplexed; selected as FP0 or BP3 by DUTY[1:0])
- BP0–BP2
- FP1–FP10
- FP11–FP18 (shared with port E)
- FP19–FP26 (shared with port C)
- FP27–FP32

**17.7.1 BP0–BP3 (Backplane Drivers)**

BP0–BP3 are the backplane driver output pins. These are connected to the backplane of the LCD panel. Depending on the LCD duty selected, the voltage waveforms in [Figure 17-5](#), [Figure 17-6](#), and [Figure 17-7](#) appear on the backplane pins.

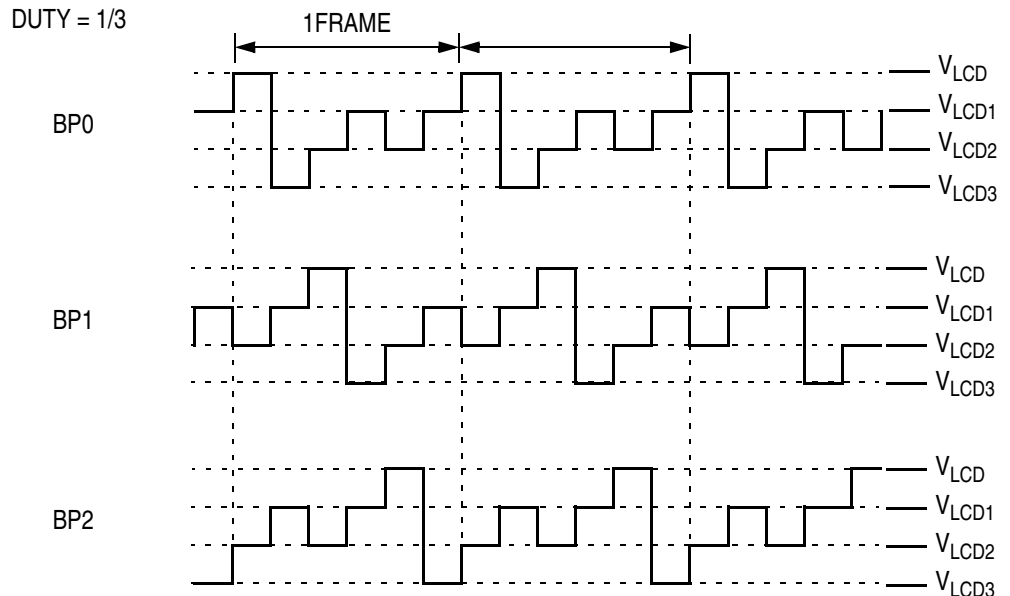
BP3 pin is only used when 1/4 duty is selected. The pin becomes FP0 for static and 1/3 duty operations.



**NOTES:**

1. BP1, BP2, and BP3 are not used.
2. At static duty, 1FRAME is equal to the cycle of LCD waveform base clock.

**Figure 17-5. Static LCD Backplane Driver Waveform**



**NOTES:**

1. BP3 is not used.
2. At 1/3 duty, 1FRAME has three times the cycle of LCD waveform base clock.

**Figure 17-6. 1/3 Duty LCD Backplane Driver Waveforms**

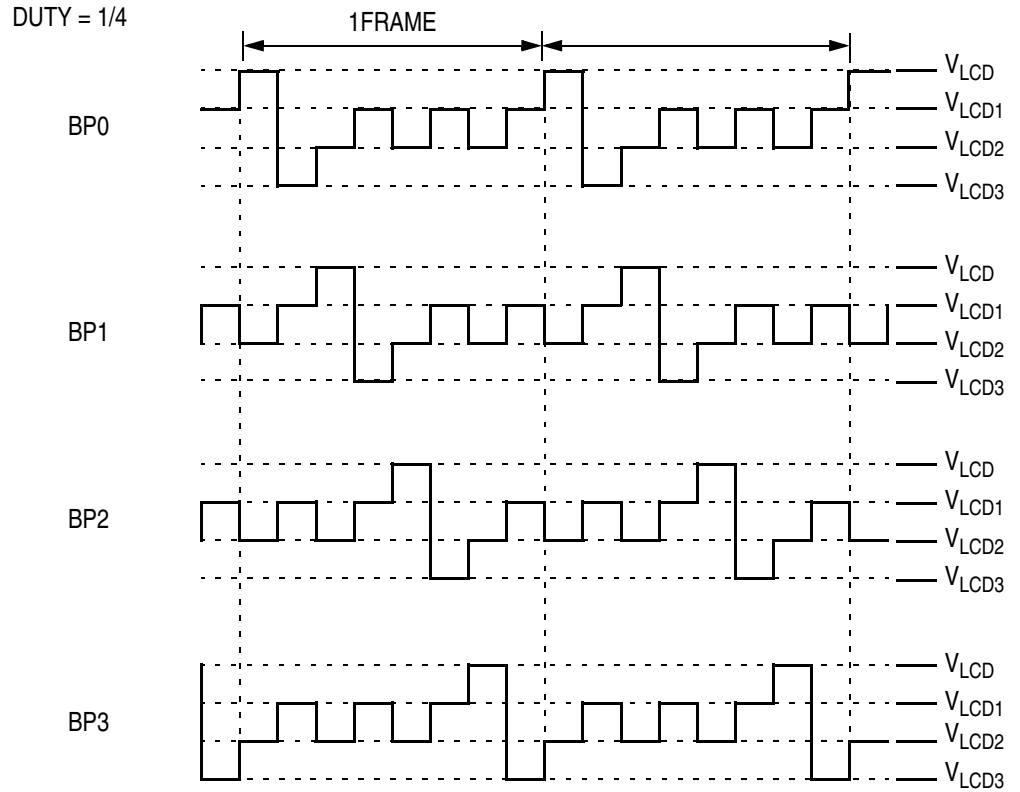


Figure 17-7. 1/4 Duty LCD Backplane Driver Waveforms



17.7.2 FP0–FP32 (Frontplane Drivers)

FP0–FP32 are the frontplane driver output pins. These are connected to the frontplane of the LCD panel. Depending on LCD duty selected and the contents in the LCD data registers, the voltage waveforms in **Figure 17-8**, **Figure 17-9**, **Figure 17-10** and **Figure 17-11** appear on the frontplane pins.

FP11–FP18 are shared with port E I/O pins. These pins are configured for standard I/O or LCD use by the PEE bit in CONFIG2 register.

FP19–FP26 are shared with port C I/O pins. These pins are configured for standard I/O or LCD use by the PCEL and PCEH bits in CONFIG2 register.

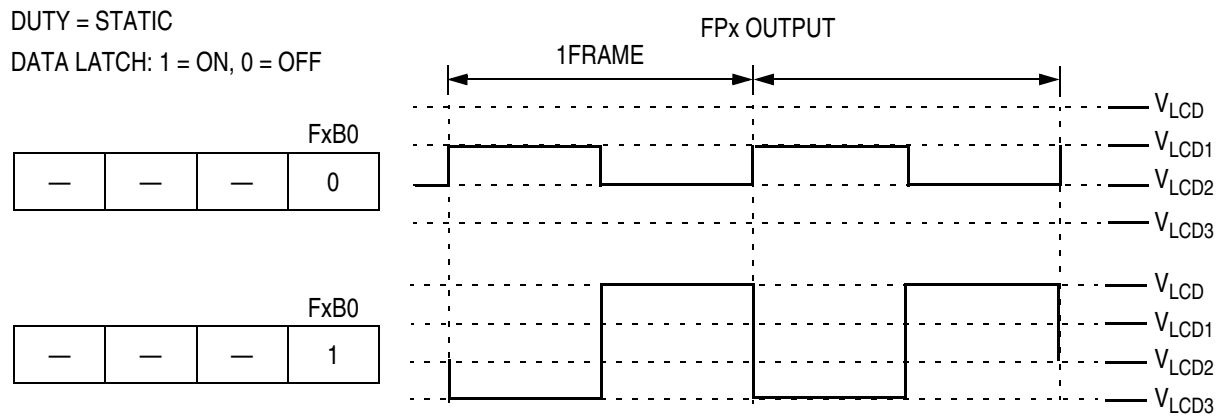


Figure 17-8. Static LCD Frontplane Driver Waveforms

Liquid Crystal Display (LCD) Driver

DUTY = 1/3

DATA LATCH: 1 = ON, 0 = OFF

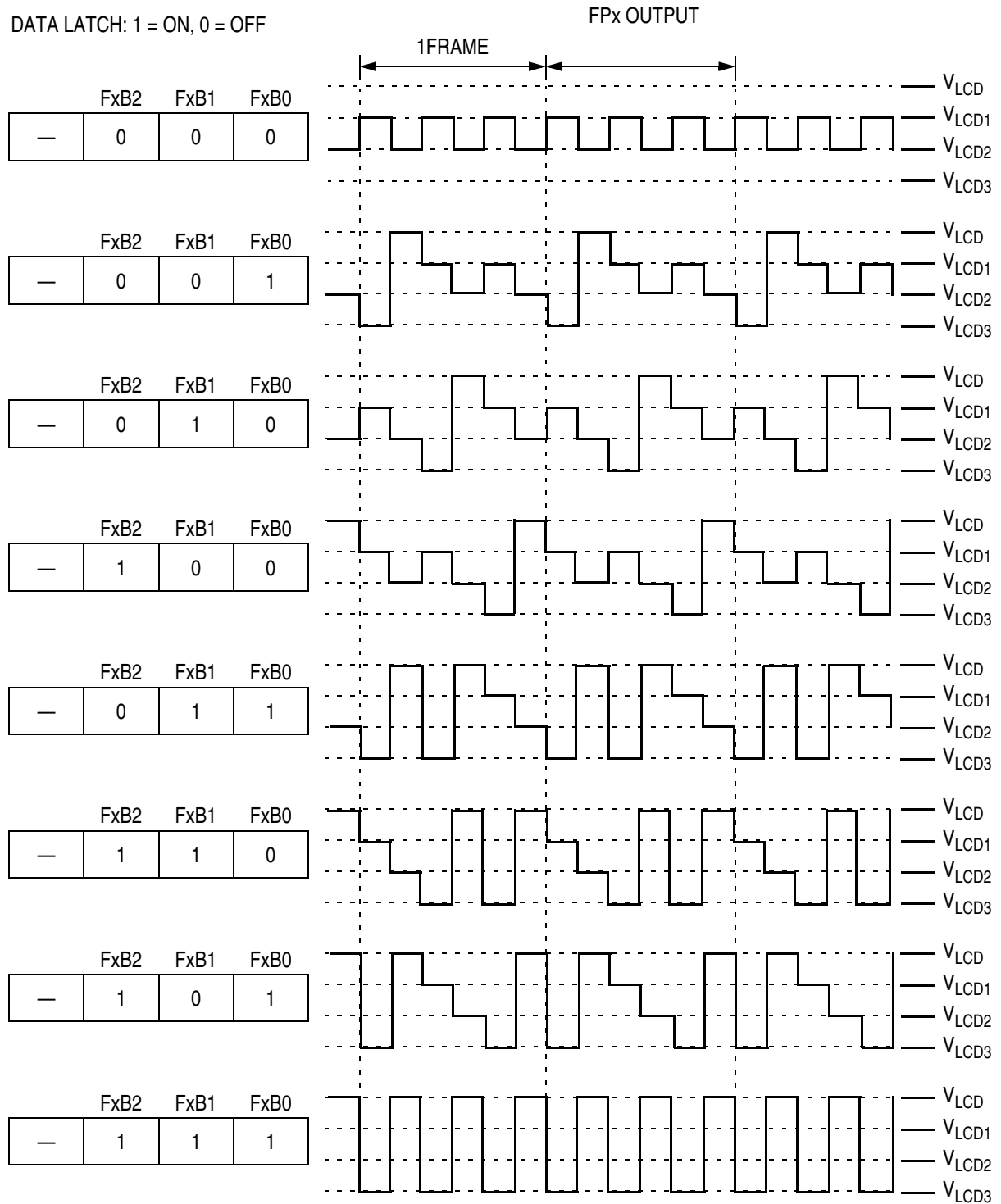


Figure 17-9. 1/3 Duty LCD Frontplane Driver Waveforms

DUTY = 1/4

DATA LATCH: 1 = ON, 0 = OFF

FxB3	FxB2	FxB1	FxB0
0	0	0	0

FxB3	FxB2	FxB1	FxB0
0	0	0	1

FxB3	FxB2	FxB1	FxB0
0	0	1	0

FxB3	FxB2	FxB1	FxB0
0	0	1	1

FxB3	FxB2	FxB1	FxB0
0	1	0	0

FxB3	FxB2	FxB1	FxB0
0	1	0	1

FxB3	FxB2	FxB1	FxB0
0	1	1	0

FxB3	FxB2	FxB1	FxB0
0	1	1	1

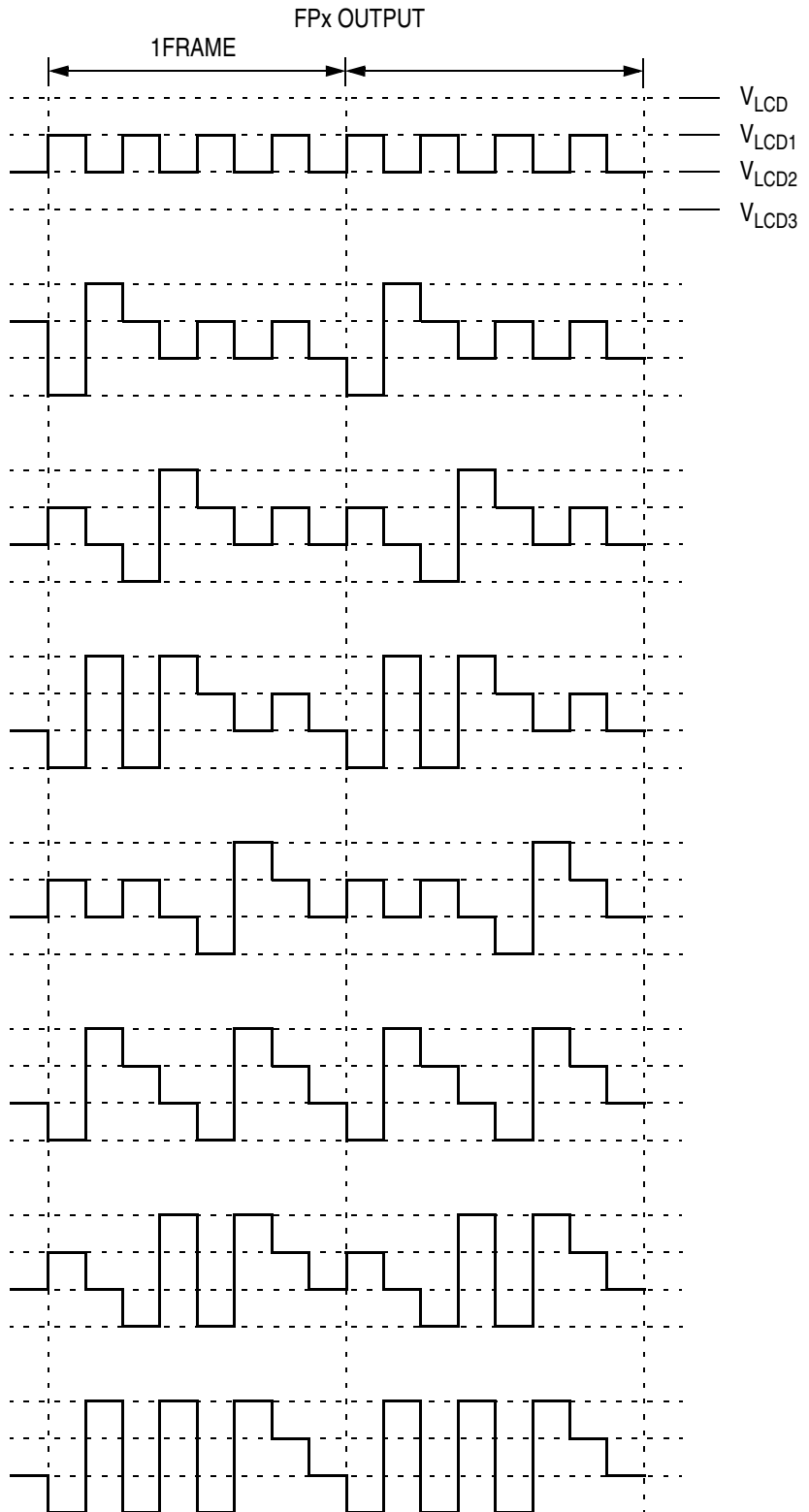


Figure 17-10. 1/4 Duty LCD Frontplane Driver Waveforms

Liquid Crystal Display (LCD) Driver

DUTY = 1/4

DATA LATCH: 1 = ON, 0 = OFF

FxB3	FxB2	FxB1	FxB0
1	0	0	0

FxB3	FxB2	FxB1	FxB0
1	0	0	1

FxB3	FxB2	FxB1	FxB0
1	0	1	0

FxB3	FxB2	FxB1	FxB0
1	0	1	1

FxB3	FxB2	FxB1	FxB0
1	1	0	0

FxB3	FxB2	FxB1	FxB0
1	1	0	1

FxB3	FxB2	FxB1	FxB0
1	1	1	0

FxB3	FxB2	FxB1	FxB0
1	1	1	1

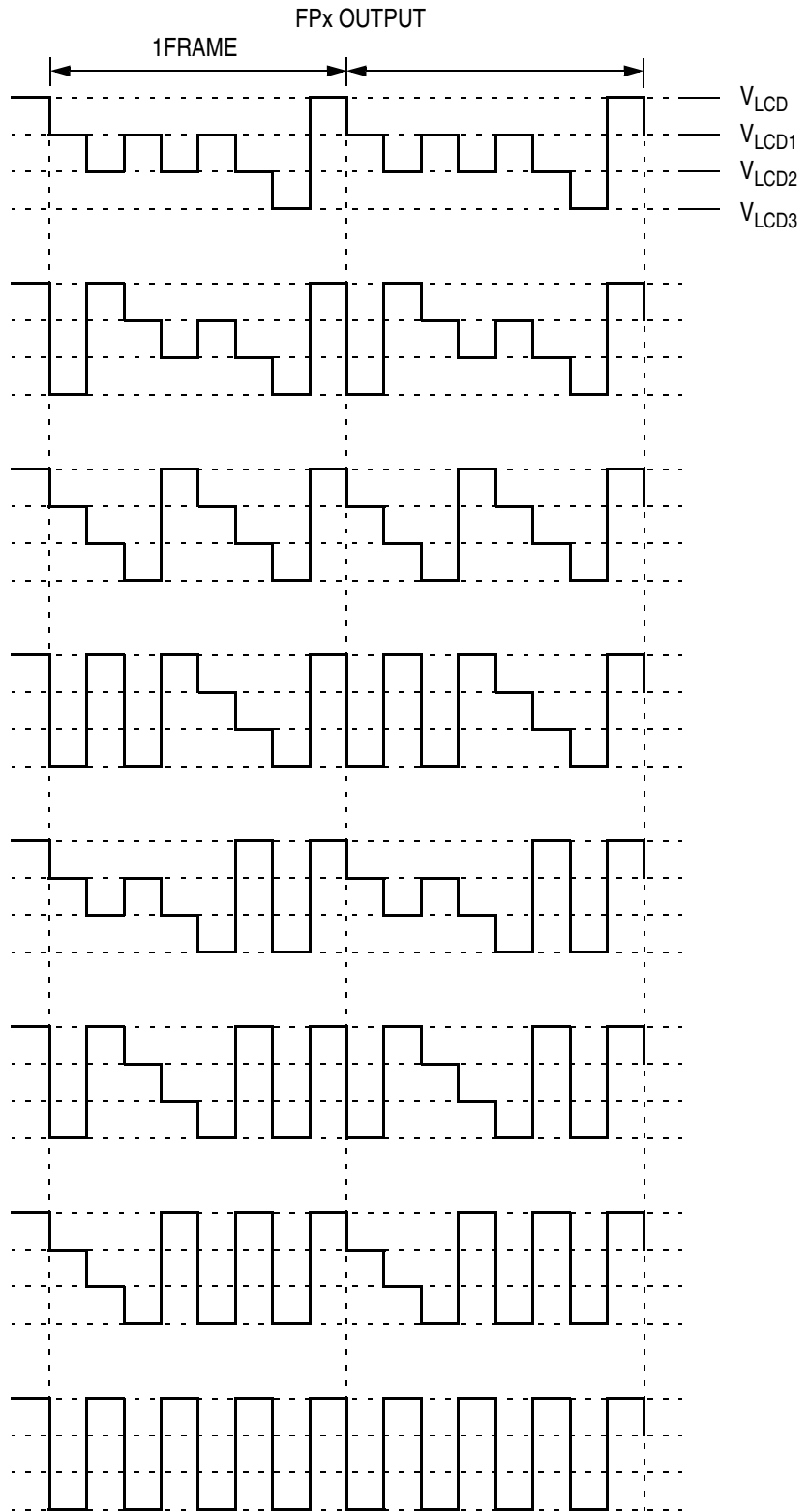
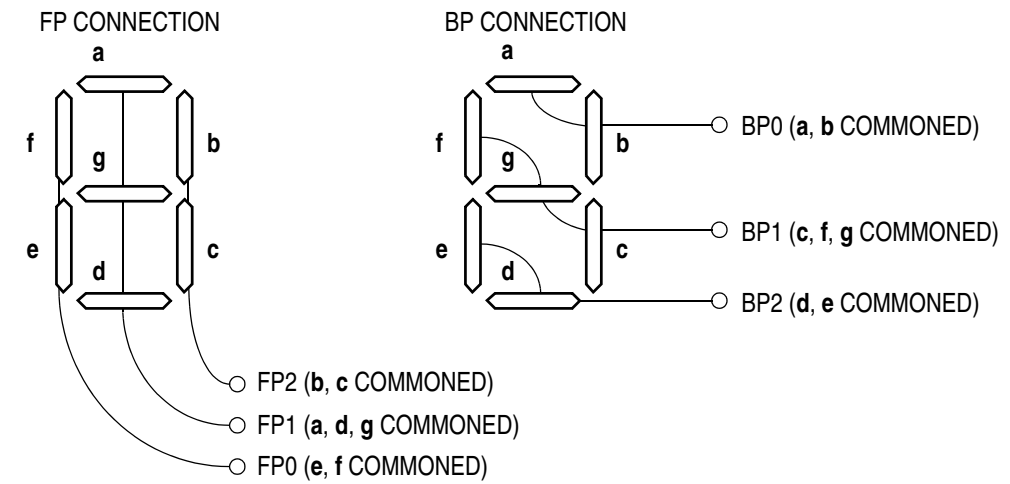


Figure 17-11. 1/4 Duty LCD Frontplane Driver Waveforms (continued)

### 17.8 Seven Segment Display Connection

The following shows an example for connecting a 7-segment LCD display to the LCD driver.

The example uses 1/3 duty cycle, with pins BP0, BP1, BP2, FP0, FP1, and FP2 connected as shown in **Figure 17-12**. The output waveforms are shown in **Figure 17-13**.



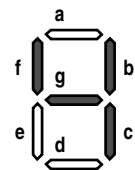
The segment assignments for each bit in the data registers are:

	F1B3	F1B2	F1B1	F1B0	F0B3	F0B2	F0B1	F0B0
LDAT1 \$0052	—	d	g	a	—	e	f	—
	← FP1 →				← FP0 →			
	F3B3	F3B2	F3B1	F3B0	F2B3	F2B2	F2B1	F2B0
LDAT2 \$0053	—	—	—	—	—	—	c	b
	← FP2 →							

To display the character "4": LDAT1 = X010X01X, LDAT2 = XXXXXX11

LDAT1 \$0052	X	0	1	0	X	0	1	X
LDAT2 \$0053	X	X	X	X	X	X	1	1

X = don't care



**Figure 17-12. 7-Segment Display Example**

DUTY = 1/3

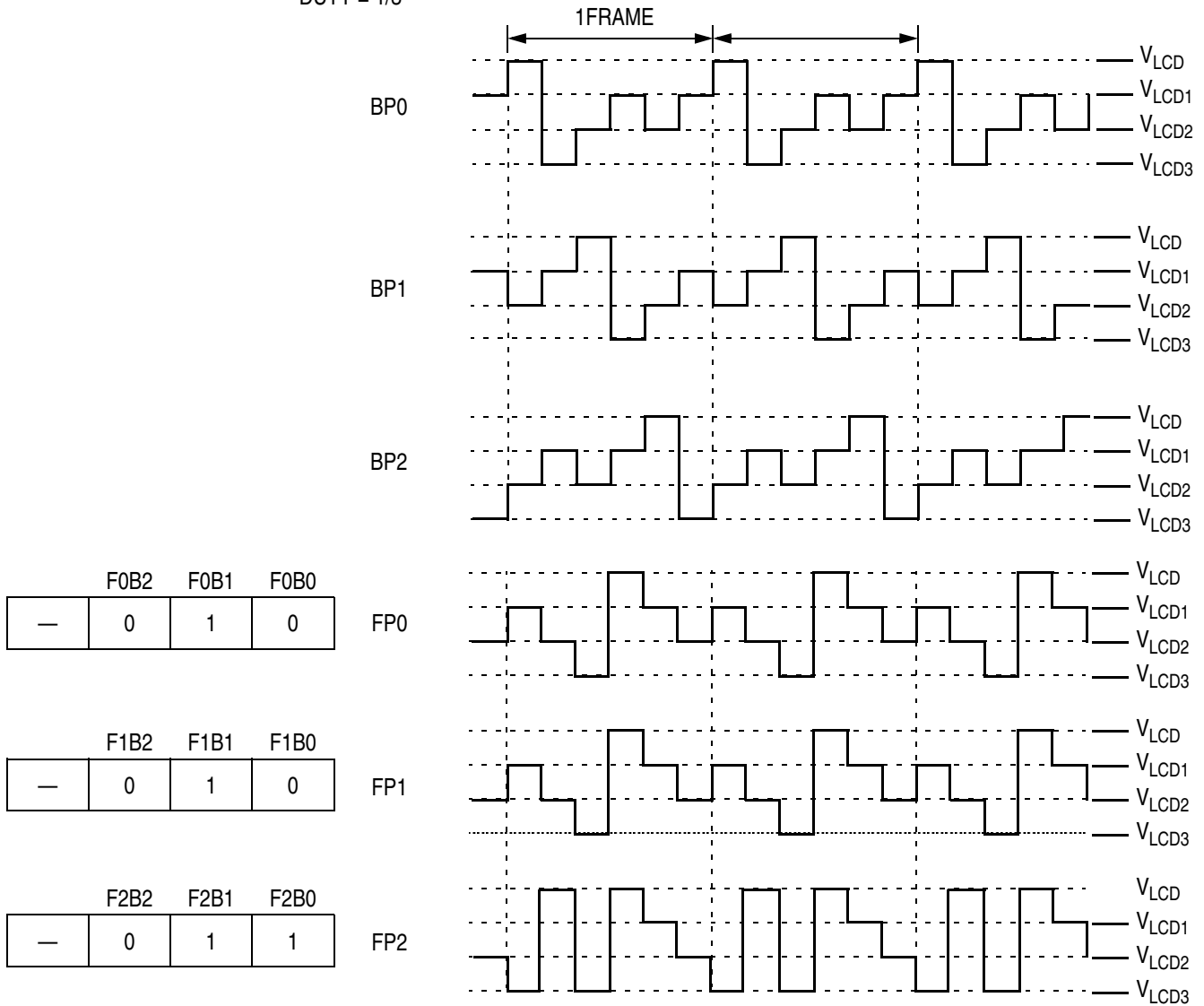
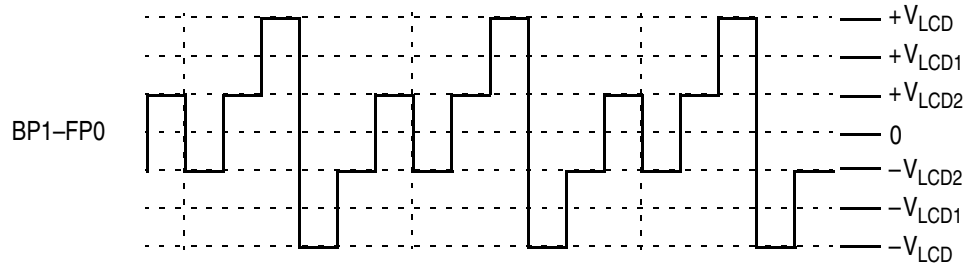


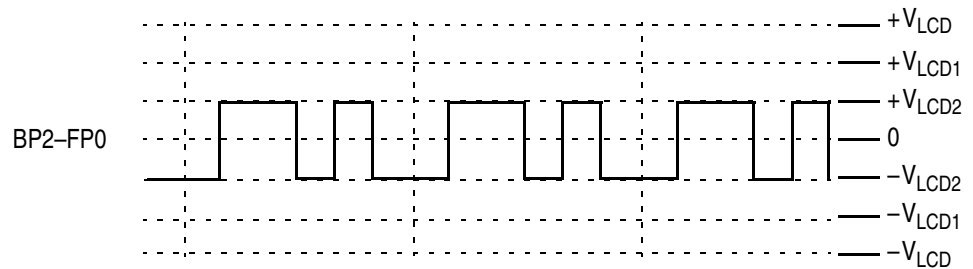
Figure 17-13. BP0–BP2 and FP0–FP2 Output Waveforms for 7-Segment Display Example

The voltage waveform across the "f" segment of the LCD (between BP1 and FP0) is illustrated in **Figure 17-14**. As shown in the waveform, the voltage peaks reach the LCD-ON voltage,  $V_{LCD}$ , therefore, the segment will be ON.



**Figure 17-14. "f" Segment Voltage Waveform**

The voltage waveform across the "e" segment of the LCD (between BP2 and FP0) is illustrated in **Figure 17-15**. As shown in the waveform, the voltage peaks do not reach the LCD-ON voltage,  $V_{LCD}$ , therefore, the segment will be OFF.



**Figure 17-15. "e" Segment Voltage Waveform**

## 17.9 I/O Registers

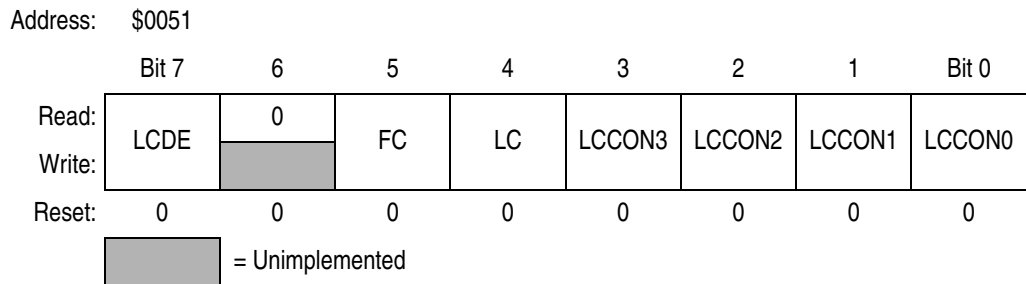
Nineteen (19) registers control LCD driver module operation:

- LCD control register (LCDCR)
- LCD clock register (LCDCLK)
- LCD data registers (LDAT1–LDAT17)

### 17.9.1 LCD Control Register (LCDCR)

The LCD control register (LCDCR):

- Enables the LCD driver module
- Selects bias resistor value and fast-charge control
- Selects LCD contrast



**Figure 17-16. LCD Control Register (LCDCR)**

#### LCDE — LCD Enable

This read/write bit enables the LCD driver module; the backplane and frontplane drive LCD waveforms out of BPx and FPx pins. Reset clears the LCDE bit.

- 1 = LCD driver module enabled
- 0 = LCD driver module disabled

#### FC — Fast Charge

#### LC — Low Current

These read/write bits are used to select the value of the resistors in resistor ladder for LCD voltages. Reset clears the FC and LC bits.



**Table 17-2. Resistor Ladder Selection**

FC	LC	Action
X	0	Each resistor is approximately 37 kΩ (default)
0	1	Each resistor is approximately 146 kΩ
1	1	Fast charge mode

**LCCON[3:0] — LCD Contrast Control**

These read/write bits select the bias voltage,  $V_{bias}$ . This voltage controls the contrast of the LCD.

Maximum contrast is set when LCCON[3:0] = %0000;  
minimum contrast is set when LCCON[3:0] = %1111.

**Table 17-3. LCD Bias Voltage Control**

LCCON3	LCCON2	LCCON1	LCCON0	Bias Voltage (% of $V_{DD}$ )
0	0	0	0	0.6
0	0	0	1	2.9
0	0	1	0	5.2
0	0	1	1	7.4
0	1	0	0	9.6
0	1	0	1	11.6
0	1	1	0	13.5
0	1	1	1	15.3
1	0	0	0	17.2
1	0	0	1	18.8
1	0	1	0	20.5
1	0	1	1	22.0
1	1	0	0	23.6
1	1	0	1	25.0
1	1	1	0	26.4
1	1	1	1	27.7

17.9.2 LCD Clock Register (LCDCLK)

The LCD clock register (LCDCLK):

- Selects the fast charge duty cycle
- Selects LCD driver duty cycle
- Selects LCD waveform base clock

Address: \$004F

	Bit 7	6	5	4	3	2	1	Bit 0
Read:	0	FCCTL1	FCCTL0	DUTY1	DUTY0	LCLK2	LCLK1	LCLK0
Write:								
Reset:	0	0	0	0	0	0	0	0


 = Unimplemented

Figure 17-17. LCD Clock Register (LCDCLK)

FCCTL[1:0] — Fast Charge Duty Cycle Select

These read/write bits select the duty cycle of the fast charge duration. Reset clears these bits. (See [17.5.4 Fast Charge and Low Current](#))

Table 17-4. Fast Charge Duty Cycle Selection

FCCTL1:FCCTL0	Fast Charge Duty Cycle
00	In each LCDCLK/2 period, each bias resistor is reduced to 37 kΩ for a duration of LCDCLK/32.
01	In each LCDCLK/2 period, each bias resistor is reduced to 37 kΩ for a duration of LCDCLK/64.
10	In each LCDCLK/2 period, each bias resistor is reduced to 37 kΩ for a duration of LCDCLK/128.
11	Not used

**DUTY[1:0] — Duty Cycle Select**

These read/write bits select the duty cycle of the LCD driver output waveforms. The multiplexed FP0/BP3 pin is controlled by the duty cycle selected. Reset clears these bits.

**Table 17-5. LCD Duty Cycle Selection**

DUTY1:DUTY0	Description
00	Static selected; FP0/BP3 pin function as FP0.
01	1/3 duty cycle selected; FP0/BP3 pin functions as FP0.
10	1/4 duty cycle selected; FP0/BP3 pin functions as BP3.
11	Not used

**LCLK[2:0] — LCD Waveform Base Clock Select**

These read/write bits selects the LCD waveform base clock. Reset clears these bits.

**Table 17-6. LCD Waveform Base Clock Selection**

LCLK2	LCLK1	LCLK0	Divide Ratio	LCD Waveform Base Clock Frequency LCDCLK (Hz)		LCD Frame Rate $f_{XTAL}^{(1)} = 32.768\text{kHz}$		LCD Frame Rate $f_{XTAL} = 4.9152\text{MHz}$			
				$f_{XTAL} = 32.768\text{kHz}$	$f_{XTAL} = 4.9152\text{MHz}$	1/3 duty	1/4 duty	1/3 duty	1/4 duty		
0	0	0	128	256	—	85.3	64	—	—		
0	0	1	256	128	—	42.7	32	—	—		
0	1	0	512	64	—	21.3	16	—	—		
0	1	1	1024	32	—	10.7	8	—	—		
1	0	0	16384	—	300	—	—	100	75		
1	0	1	32768	—	150	—	—	50	37.5		
1	1	0	65536	—	75	—	—	25	18.75		
1	1	1	Reserved								

**Notes:**

1.  $f_{XTAL}$  is the same as CGMXCLK (see [Section 7. Oscillator \(OSC\)](#)).

Liquid Crystal Display (LCD) Driver

17.9.3 LCD Data Registers (LDAT1–LDAT17)

The seventeen (17) LCD data registers enable and disable the drive to the corresponding LCD segments.

Addr.	Register Name	Bit 7	6	5	4	3	2	1	Bit 0	
\$0052	LCD Data Register 1 (LDAT1)	Read:	F1B3	F1B2	F1B1	F1B0	F0B3	F0B2	F0B1	F0B0
		Write:								
		Reset:	U	U	U	U	U	U	U	U
\$0053	LCD Data Register 2 (LDAT2)	Read:	F3B3	F3B2	F3B1	F3B0	F2B3	F2B2	F2B1	F2B0
		Write:								
		Reset:	U	U	U	U	U	U	U	U
\$0054	LCD Data Register 3 (LDAT3)	Read:	F5B3	F5B2	F5B1	F5B0	F4B3	F4B2	F4B1	F4B0
		Write:								
		Reset:	U	U	U	U	U	U	U	U
\$0055	LCD Data Register 4 (LDAT4)	Read:	F7B3	F7B2	F7B1	F7B0	F6B3	F6B2	F6B1	F6B0
		Write:								
		Reset:	U	U	U	U	U	U	U	U
\$0056	LCD Data Register 5 (LDAT5)	Read:	F9B3	F9B2	F9B1	F9B0	F8B3	F8B2	F8B1	F8B0
		Write:								
		Reset:	U	U	U	U	U	U	U	U
\$0057	LCD Data Register 6 (LDAT6)	Read:	F11B3	F11B2	F11B1	F11B0	F10B3	F10B2	F10B1	F10B0
		Write:								
		Reset:	U	U	U	U	U	U	U	U
\$0058	LCD Data Register 7 (LDAT7)	Read:	F13B3	F13B2	F13B1	F13B0	F12B3	F12B2	F12B1	F12B0
		Write:								
		Reset:	U	U	U	U	U	U	U	U
\$0059	LCD Data Register 8 (LDAT8)	Read:	F15B3	F15B2	F15B1	F15B0	F14B3	F14B2	F14B1	F14B0
		Write:								
		Reset:	U	U	U	U	U	U	U	U
\$005A	LCD Data Register 9 (LDAT9)	Read:	F17B3	F17B2	F17B1	F17B0	F16B3	F16B2	F16B1	F16B0
		Write:								
		Reset:	U	U	U	U	U	U	U	U


U = Unaffected       = Unimplemented

Figure 17-18. LCD Data Registers 1–17 (LDAT1–LDAT17)

\$005B	LCD Data Register 10 (LDAT10)	Read: Write: Reset:	F19B3	F19B2	F19B1	F19B0	F18B3	F18B2	F18B1	F18B0	U	U	U	U	U	U	U
\$005C	LCD Data Register 11 (LDAT11)	Read: Write: Reset:	F21B3	F21B2	F21B1	F21B0	F20B3	F20B2	F20B1	F20B0	U	U	U	U	U	U	U
\$005D	LCD Data Register 12 (LDAT12)	Read: Write: Reset:	F23B3	F23B2	F23B1	F23B0	F22B3	F22B2	F22B1	F22B0	U	U	U	U	U	U	U
\$005E	LCD Data Register 13 (LDAT13)	Read: Write: Reset:	F25B3	F25B2	F25B1	F25B0	F24B3	F24B2	F24B1	F24B0	U	U	U	U	U	U	U
\$005F	LCD Data Register 14 (LDAT14)	Read: Write: Reset:	F27B3	F27B2	F27B1	F27B0	F26B3	F26B2	F26B1	F26B0	U	U	U	U	U	U	U
\$0060	LCD Data Register 15 (LDAT15)	Read: Write: Reset:	F29B3	F29B2	F29B1	F29B0	F28B3	F28B2	F28B1	F28B0	U	U	U	U	U	U	U
\$0061	LCD Data Register 16 (LDAT16)	Read: Write: Reset:	F31B3	F31B2	F31B1	F31B0	F30B3	F30B2	F30B1	F30B0	U	U	U	U	U	U	U
\$0062	LCD Data Register 17 (LDAT17)	Read: Write: Reset:					F32B3	F32B2	F32B1	F32B0	U	U	U	U	U	U	U

U = Unaffected       = Unimplemented

**Figure 17-18. LCD Data Registers 1–17 (LDAT1–LDAT17)**



## Section 18. Input/Output (I/O) Ports

### 18.1 Contents

18.2	Introduction	376
18.3	Port A	380
18.3.1	Port A Data Register (PTA)	380
18.3.2	Data Direction Register A (DDRA)	381
18.4	Port B	383
18.4.1	Port B Data Register (PTB)	383
18.4.2	Data Direction Register B (DDRB)	385
18.4.3	Port B LED Control Register (LEDB)	386
18.5	Port C	387
18.5.1	Port C Data Register (PTC)	387
18.5.2	Data Direction Register C (DDRC)	388
18.5.3	Port C LED Control Register (LEDC)	389
18.6	Port D	390
18.6.1	Port D Data Register (PTD)	390
18.6.2	Data Direction Register D (DDRD)	392
18.7	Port E	394
18.7.1	Port E Data Register (PTE)	394
18.7.2	Data Direction Register E (DDRE)	395
18.7.3	Port E LED Control Register (LEDE)	396
18.8	Port F	397
18.8.1	Port F Data Register (PTF)	397
18.8.2	Data Direction Register F (DDRF)	398
18.8.3	Port F LED Control Register (LEDF)	399

Input/Output (I/O) Ports

18.2 Introduction

Forty-eight (48) bidirectional input-output (I/O) pins form six parallel ports. All I/O pins are programmable as inputs or outputs.

**NOTE:** Connect any unused I/O pins to an appropriate logic level, either  $V_{DD}$  or  $V_{SS}$ . Although the I/O ports do not require termination for proper operation, termination reduces excess current consumption and the possibility of electrostatic damage.

Addr.	Register Name	Bit 7	6	5	4	3	2	1	Bit 0	
\$0000	Port A Data Register (PTA)	Read:	PTA7	PTA6	PTA5	PTA4	PTA3	PTA2	PTA1	PTA0
		Write:	PTA7	PTA6	PTA5	PTA4	PTA3	PTA2	PTA1	PTA0
		Reset:	Unaffected by reset							
\$0001	Port B Data Register (PTB)	Read:	PTB7	PTB6	PTB5	PTB4	PTB3	PTB2	PTB1	PTB0
		Write:	PTB7	PTB6	PTB5	PTB4	PTB3	PTB2	PTB1	PTB0
		Reset:	Unaffected by reset							
\$0002	Port C Data Register (PTC)	Read:	PTC7	PTC6	PTC5	PTC4	PTC3	PTC2	PTC1	PTC0
		Write:	PTC7	PTC6	PTC5	PTC4	PTC3	PTC2	PTC1	PTC0
		Reset:	Unaffected by reset							
\$0003	Port D Data Register (PTD)	Read:	PTD7	PTD6	PTD5	PTD4	PTD3	PTD2	PTD1	PTD0
		Write:	PTD7	PTD6	PTD5	PTD4	PTD3	PTD2	PTD1	PTD0
		Reset:	Unaffected by reset							
\$0004	Data Direction Register A (DDRA)	Read:	DDRA7	DDRA6	DDRA5	DDRA4	DDRA3	DDRA2	DDRA1	DDRA0
		Write:	DDRA7	DDRA6	DDRA5	DDRA4	DDRA3	DDRA2	DDRA1	DDRA0
		Reset:	0	0	0	0	0	0	0	0
\$0005	Data Direction Register B (DDRB)	Read:	DDRB7	DDRB6	DDRB5	DDRB4	DDRB3	DDRB2	DDRB1	DDRB0
		Write:	DDRB7	DDRB6	DDRB5	DDRB4	DDRB3	DDRB2	DDRB1	DDRB0
		Reset:	0	0	0	0	0	0	0	0
\$0006	Data Direction Register C (DDRC)	Read:	DDRC7	DDRC6	DDRC5	DDRC4	DDRC3	DDRC2	DDRC1	DDRC0
		Write:	DDRC7	DDRC6	DDRC5	DDRC4	DDRC3	DDRC2	DDRC1	DDRC0
		Reset:	0	0	0	0	0	0	0	0
\$0007	Data Direction Register D (DDRD)	Read:	DDRD7	DDRD6	DDRD5	DDRD4	DDRD3	DDRD2	DDRD1	DDRD0
		Write:	DDRD7	DDRD6	DDRD5	DDRD4	DDRD3	DDRD2	DDRD1	DDRD0
		Reset:	0	0	0	0	0	0	0	0

Figure 18-1. I/O Port Register Summary



Addr.	Register Name	Bit 7	6	5	4	3	2	1	Bit 0	
\$0008	Port E Data Register (PTE)	Read:	PTE7	PTE6	PTE5	PTE4	PTE3	PTE2	PTE1	PTE0
		Write:								
		Reset:	U	U	U	U	U	U	U	U
\$0009	Data Direction Register E (DDRE)	Read:	DDRE7	DDRE6	DDRE5	DDRE4	DDRE3	DDRE2	DDRE1	DDRE0
		Write:								
		Reset:	0	0	0	0	0	0	0	0
\$000A	Port F Data Register (PTF)	Read:	PTF7	PTF6	PTF5	PTF4	PTF3	PTF2	PTF1	PTF0
		Write:								
		Reset:	U	U	U	U	U	U	U	U
\$000B	Data Direction Register F (DDRF)	Read:	DDRF7	DDRF6	DDRF5	DDRF4	DDRF3	DDRF2	DDRF1	DDRF0
		Write:								
		Reset:	0	0	0	0	0	0	0	0
\$000C	Port-B LED Control Register (LEDB)	Read:	0	0	LEDB5	LEDB4	LEDB3	LEDB2	LEDB1	LEDB0
		Write:								
		Reset:	0	0	0	0	0	0	0	0
\$000D	Port-C LED Control Register (LEDC)	Read:	LEDC7	LEDC6	LEDC5	LEDC4	LEDC3	LEDC2	LEDC1	LEDC0
		Write:								
		Reset:	0	0	0	0	0	0	0	0
\$000E	Port-E LED Control Register (LEDE)	Read:	LEDE7	LEDE6	LEDE5	LEDE4	LEDE3	LEDE2	LEDE1	LEDE0
		Write:								
		Reset:	0	0	0	0	0	0	0	0
\$000F	Port-F LED Control Register (LEDF)	Read:	LEDF7	LEDF6	LEDF5	LEDF4	LEDF3	LEDF2	LEDF1	LEDF0
		Write:								
		Reset:	0	0	0	0	0	0	0	0

Figure 18-1. I/O Port Register Summary

Table 18-1. Port Control Register Bits Summary (Sheet 1 of 2)

Port	Bit	DDR	Module Control			Pin
			Module	Register	Control Bit	
A	0	DDRA0	KBI	KBIER (\$001C)	KBIE0	PTA0/KBI0
	1	DDRA1			KBIE1	PTA1/KBI1
	2	DDRA2			KBIE2	PTA2/KBI2
	3	DDRA3			KBIE3	PTA3/KBI3
	4	DDRA4	ADC	ADSCR (\$003C)	ADCH[4:0]	PTA4/ADC0
	5	DDRA5				PTA5/ADC1
	6	DDRA6				PTA6/ADC2
	7	DDRA7				PTA7/ADC3
B	0	DDRB0	SCI	SCC1 (\$0013)	ENSCI	PTB0/TxD
	1	DDRB1				PTB1/RxD
	2	DDRB2	TIM1	T1SC0 (\$0025)	ELS0B:ELS0A	PTB2/T1CH0
	3	DDRB3		T1SC1 (\$0028)	ELS1B:ELS1A	PTB3/T1CH1
	4	DDRB4	TIM2	T2SC0 (\$0030)	ELS0B:ELS0A	PTB4/T2CH0
	5	DDRB5		T2SC1 (\$0033)	ELS1B:ELS1A	PTB5/T2CH1
	6	DDRB6	ADC	ADSCR (\$003C)	ADCH[4:0]	PTB6/ADC4
	7	DDRB7				PTB7/ADC5
C	0	DDRC0	LCD	CONFIG2 (\$001D)	PCEL	PTC0/FP19
	1	DDRC1				PTC1/FP20
	2	DDRC2				PTC2/FP21
	3	DDRC3				PTC3/FP22
	4	DDRC4			PCEH	PTC4/FP23
	5	DDRC5				PTC5/FP24
	6	DDRC6				PTC6/FP25
	7	DDRC7				PTC7/FP26

Table 18-1. Port Control Register Bits Summary (Sheet 2 of 2)

Port	Bit	DDR	Module Control			Pin	
			Module	Register	Control Bit		
D <sup>(1)</sup>	0	DDRD0	SPI RTC	SPCR (\$0010)	SPE	PTD0/ $\overline{SS}$ /CALIN	
				RTCCOMR (\$0040)	CAL		
	1	DDRD1		SPCR (\$0010)	SPE	PTD1/MISO	
	2	DDRD2				PTD2/MOSI	
	3	DDRD3		SPCR (\$0010)	SPE	PTD3/SPSCK/CALOUT	
				RTCCOMR (\$0040)	CAL		
	4	DDRD4		KBI TIM	KBIER (\$001C)	KBIE4	PTD4/KBI4/T1CLK
					T1SC (\$0020)	PS[2:0]	
	5	DDRD5			KBIER (\$001C)	KBIE5	PTD5/KBI5/T2CLK
					T2SC (\$002B)	PS[2:0]	
6	DDRD6	KBI MMIIC	KBIER (\$001C)	KBIE6	PTD6/KBI6/SCL		
			MMCR (\$006C)	MMEN			
7	DDRD7		KBIER (\$001C)	KBIE7	PTD7/KBI7/SDA		
			MMCR (\$006C)	MMEN			
E	0	DDRE0	LCD	CONFIG2 (\$001D)	PEE	PTE0/FP11	
	1	DDRE1				PTE1/FP12	
	2	DDRE2				PTE2/FP13	
	3	DDRE3				PTE3/FP14	
	4	DDRE4				PTE4/FP15	
	5	DDRE5				PTE5/FP16	
	6	DDRE6				PTE6/FP17	
	7	DDRE7				PTE7/FP18	
F	0	DDRF0	—	—	—	PTF0	
	1	DDRF1				PTF1	
	2	DDRF2				PTF2	
	3	DDRF3				PTF3	
	4	DDRF4				PTF4	
	5	DDRF5				PTF5	
	6	DDRF6				PTF6	
	7	DDRF7				PTF7	

**Notes:**

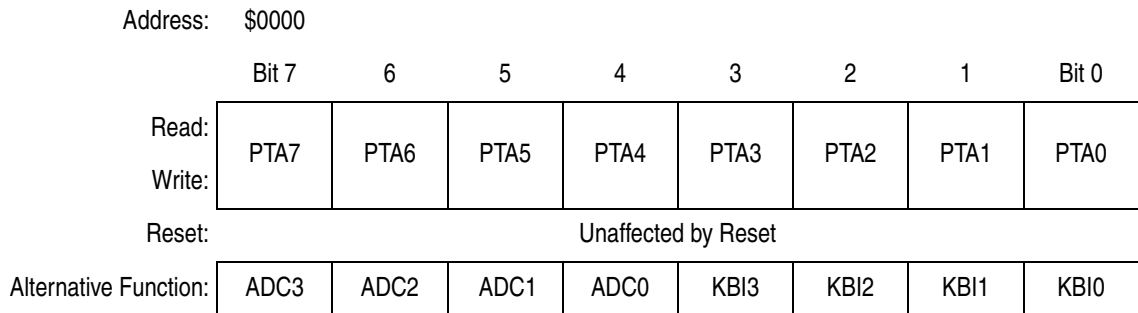
- In addition to the standard I/O function on PTD0 and PTD3–PTD7 pins, these pins are shared with two other modules. For each of the pins, ONLY enable ONE module at any one time to avoid pin contention.

### 18.3 Port A

Port A is an 8-bit special function port that shares four of its port pins with the analog-to-digital converter (ADC) module and four of its port pins with the keyboard interrupt module (KBI).

#### 18.3.1 Port A Data Register (PTA)

The port A data register contains a data latch for each of the eight port A pins.



**Figure 18-2. Port A Data Register (PTA)**

#### PTA[7:0] — Port A Data Bits

These read/write bits are software programmable. Data direction of each port A pin is under the control of the corresponding bit in data direction register A. Reset has no effect on port A data.

#### KBI[3:0] — Keyboard Interrupt Channels 3 to 0

KBI[3:0] are pins used for the keyboard interrupt input. The corresponding input, KBI[3:0], can be enabled in the keyboard interrupt enable register, KBIER. Port pins used as KBI input will override any control from the port I/O logic. See [Section 20](#).

[Keyboard Interrupt Module \(KBI\)](#).

ADC[3:0] — ADC channels 0 to 3

ADC[3:0] are pins used for the input channels to the analog-to-digital converter module. The channel select bits, ADCH[4:0], in the ADC status and control register define which port pin will be used as an ADC input and overrides any control from the port I/O logic. See [Section 16. Analog-to-Digital Converter \(ADC\)](#).

**NOTE:** Care must be taken when reading port A while applying analog voltages to ADC[3:0] pins. If the appropriate ADC channel is not enabled, excessive current drain may occur if analog voltages are applied to the PTAx/ADCx pin, while PTA is read as a digital input. Those ports not selected as analog input channels are considered digital I/O ports.

18.3.2 Data Direction Register A (DDRA)

Data direction register A determines whether each port A pin is an input or an output. Writing a logic 1 to a DDRA bit enables the output buffer for the corresponding port A pin; a logic 0 disables the output buffer.

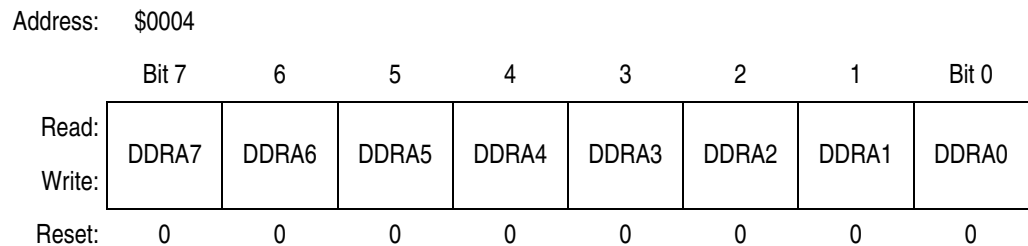


Figure 18-3. Data Direction Register A (DDRA)

DDRA[7:0] — Data Direction Register A Bits

These read/write bits control port A data direction. Reset clears DDRA[7:0], configuring all port A pins as inputs.

- 1 = Corresponding port A pin configured as output
- 0 = Corresponding port A pin configured as input

**NOTE:** Avoid glitches on port A pins by writing to the port A data register before changing data direction register A bits from 0 to 1. [Figure 18-4](#) shows the port A I/O logic.

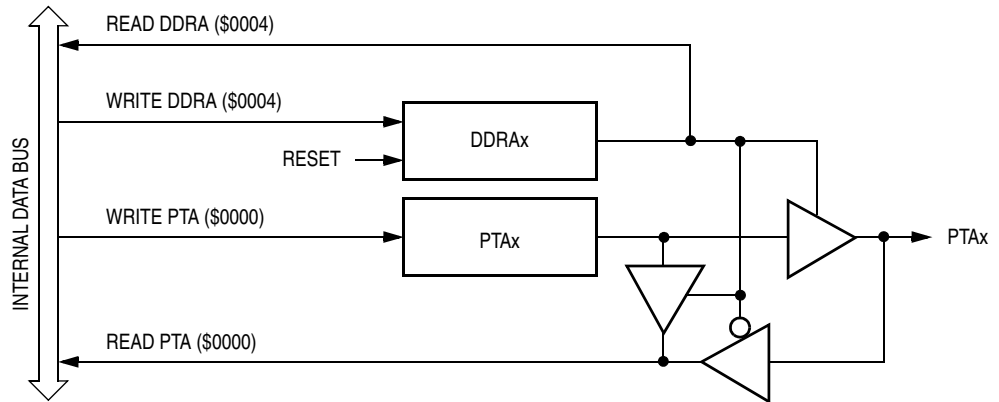


Figure 18-4. Port A I/O Circuit

When DDRAx is a logic 1, reading address \$0000 reads the PTAx data latch. When DDRAx is a logic 0, reading address \$0000 reads the voltage level on the pin. The data latch can always be written, regardless of the state of its data direction bit.

Table 18-2 summarizes the operation of the port A pins.

Table 18-2. Port A Pin Functions

DDRA Bit	PTA Bit	I/O Pin Mode	Accesses to DDRA			Accesses to PTA	
			Read/Write			Read	Write
0	X <sup>(1)</sup>	Input, Hi-Z <sup>(2)</sup>	DDRA[7:0]			Pin	PTA[7:0] <sup>(3)</sup>
1	X	Output	DDRA[7:0]			PTA[7:0]	PTA[7:0]

Notes:

1. X = don't care.
2. Hi-Z = high impedance.
3. Writing affects data register, but does not affect input.

## 18.4 Port B

Port B is a 8-bit special function port that shares two of its port pins with the infrared serial communication interface (IRSCI) module, two of its port pins with the timer interface module 1 (TIM1) module, two of its port pins with the timer interface module 2 (TIM2), and two of its port pins with the ADC module.

Port pins PTB0–PTB5 can be configured for direct LED drive.

### 18.4.1 Port B Data Register (PTB)

The port B data register contains a data latch for each of the eight port B pins.

Address:	\$0001							
	Bit 7	6	5	4	3	2	1	Bit 0
Read:	PTB7	PTB6	PTB5	PTB4	PTB3	PTB2	PTB1	PTB0
Write:	PTB7	PTB6	PTB5	PTB4	PTB3	PTB2	PTB1	PTB0
Reset:	Unaffected by reset							
Alternative Function:	ADC5	ADC4	T2CH1	T2CH0	T1CH1	T1CH0	RxD	TxD
Additional Function:			LED drive	LED drive	LED drive	LED drive	LED drive	LED drive

**Figure 18-5. Port B Data Register (PTB)**

#### PTB[7:0] — Port B Data Bits

These read/write bits are software programmable. Data direction of each port B pin is under the control of the corresponding bit in data direction register B. Reset has no effect on port B data.

#### TxD, RxD — SCI Data I/O Pins

The TxD and RxD pins are the transmit data output and receive data input for the IRSCI module. The enable SCI bit, ENSCI, in the SCI control register 1 enables the PTB0/TxD and PTB1/RxD pins as SCI TxD and RxD pins and overrides any control from the port I/O. See [Section 13. Infrared Serial Communications Interface Module \(IRSCI\)](#).

## T1CH[1:0] — Timer 1 Channel I/O Bits

The T1CH1 and T1CH0 pins are the TIM1 input capture/output compare pins. The edge/level select bits, ELSxB:ELSxA, determine whether the PTB2/T1CH0 and PTB3/T1CH1 pins are timer channel I/O pins or general-purpose I/O pins. See [Section 11. Timer Interface Module \(TIM\)](#).

## T2CH[1:0] — Timer 2 Channel I/O Bits

The T2CH1 and T2CH0 pins are the TIM1 input capture/output compare pins. The edge/level select bits, ELSxB:ELSxA, determine whether the PTB4/T2CH0 and PTB5/T2CH1 pins are timer channel I/O pins or general-purpose I/O pins. See [Section 11. Timer Interface Module \(TIM\)](#).

## ADC[5:4] — ADC Channels 5 and 4

ADC[5:4] are pins used for the input channels to the analog-to-digital converter module. The channel select bits, ADCH[4:0], in the ADC status and control register define which port pin will be used as an ADC input and overrides any control from the port I/O logic. See [Section 16. Analog-to-Digital Converter \(ADC\)](#).

**NOTE:** *Care must be taken when reading port B while applying analog voltages to ADC[5:4] pins. If the appropriate ADC channel is not enabled, excessive current drain may occur if analog voltages are applied to the PTBx/ADCx pin, while PTB is read as a digital input. Those ports not selected as analog input channels are considered digital I/O ports.*

## LED Drive — Direct LED Drive Pins

PTB0–PTB5 pins can be configured for direct LED drive. See [18.4.3 Port B LED Control Register \(LEDB\)](#).



18.4.2 Data Direction Register B (DDRB)

Data direction register B determines whether each port B pin is an input or an output. Writing a logic 1 to a DDRB bit enables the output buffer for the corresponding port B pin; a logic 0 disables the output buffer.

Address: \$0005

	Bit 7	6	5	4	3	2	1	Bit 0
Read:	DDRB7	DDRB6	DDRB5	DDRB4	DDRB3	DDRB2	DDRB1	DDRB0
Write:								
Reset:	0	0	0	0	0	0	0	0

Figure 18-6. Data Direction Register B (DDRB)

DDRB[7:0] — Data Direction Register B Bits

These read/write bits control port B data direction. Reset clears DDRB[7:0], configuring all port B pins as inputs.

- 1 = Corresponding port B pin configured as output
- 0 = Corresponding port B pin configured as input

**NOTE:** Avoid glitches on port B pins by writing to the port B data register before changing data direction register B bits from 0 to 1. Figure 18-7 shows the port B I/O logic.

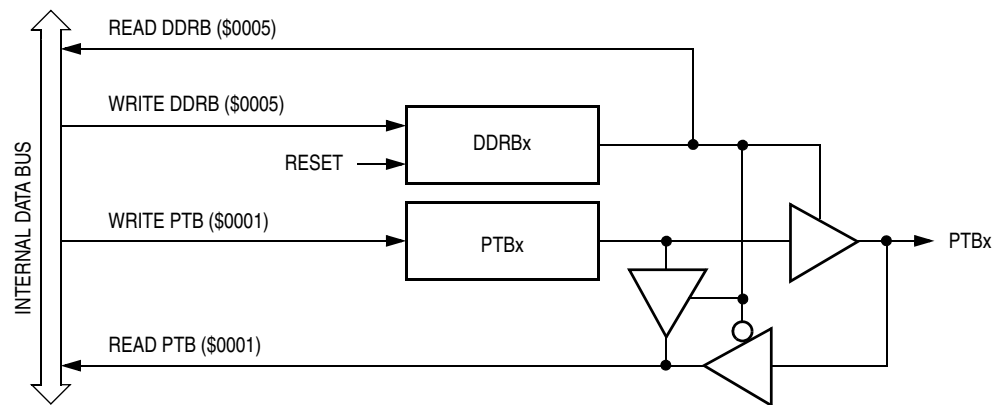


Figure 18-7. Port B I/O Circuit

When DDRBx is a logic 1, reading address \$0001 reads the PTBx data latch. When DDRBx is a logic 0, reading address \$0001 reads the voltage level on the pin. The data latch can always be written, regardless of the state of its data direction bit.

Table 18-3 summarizes the operation of the port B pins.

Table 18-3. Port B Pin Functions

DDRB Bit	PTB Bit	I/O Pin Mode	Accesses to DDRB	Accesses to PTB	
			Read/Write	Read	Write
0	X <sup>(1)</sup>	Input, Hi-Z <sup>(2)</sup>	DDRB[7:0]	Pin	PTB[7:0] <sup>(3)</sup>
1	X	Output	DDRB[7:0]	PTB[7:0]	PTB[7:0]

Notes:

1. X = don't care.
2. Hi-Z = high impedance.
3. Writing affects data register, but does not affect input.

### 18.4.3 Port B LED Control Register (LEDB)

The port-B LED control register (LEDB) controls the direct LED drive capability on PTB5–PTB0 pins. Each bit is individually configurable and requires that the data direction register, DDRB, bit be configured as an output.

When the IRSCI is enabled, setting the LEDB0 bit also enables high current (15mA) sink capability for the TxD pin.

Address: \$000C

	Bit 7	6	5	4	3	2	1	Bit 0
Read:	0	0	LEDB5	LEDB4	LEDB3	LEDB2	LEDB1	LEDB0
Write:								
Reset:	0	0	0	0	0	0	0	0

Figure 18-8. Port B LED Control Register (LEDB)

#### LEDB[5:0] — Port B LED Drive Enable Bits

These read/write bits are software programmable to enable the direct LED drive on an output port pin.

- 1 = Corresponding port B pin is configured for direct LED drive, with 15mA current sinking capability
- 0 = Corresponding port B pin is configured for standard drive

## 18.5 Port C

Port C is an 8-bit special function port that shares all of its port pins with the liquid crystal display (LCD) driver module.

Port pins PTC0–PTC7 can be configured for direct LED drive.

### 18.5.1 Port C Data Register (PTC)

The port C data register contains a data latch for each of the eight port C pins.

Address: \$0002

	Bit 7	6	5	4	3	2	1	Bit 0
Read:	PTC7	PTC6	PTC5	PTC4	PTC3	PTC2	PTC1	PTC0
Write:								
Reset:	Unaffected by reset							
Alternative Function:	FP26	FP25	FP24	FP23	FP22	FP21	FP20	FP19
Additional Function:	LED drive	LED drive	LED drive	LED drive	LED drive	LED drive	LED drive	LED drive

**Figure 18-9. Port C Data Register (PTC)**

#### PTC[7:0] — Port C Data Bits

These read/write bits are software programmable. Data direction of each port C pin is under the control of the corresponding bit in data direction register C. Reset has no effect on port C data.

#### FP[26:19] — LCD Driver Frontplanes 26–19

FP[26:19] are pins used for the frontplane output of the LCD driver module. The enable bits, PCEH and PCEL, in the CONFIG2 register, determine whether the PTC7/FP26–PTC4/FP23 and PTC3/FP22–PTC0/FP19 pins are LCD frontplane driver pins or general-purpose I/O pins. See [Section 17. Liquid Crystal Display \(LCD\) Driver](#).

#### LED drive — Direct LED Drive Pins

PTC0–PTC7 pins can be configured for direct LED drive. See [18.5.3 Port C LED Control Register \(LEDC\)](#).

18.5.2 Data Direction Register C (DDRC)

Data direction register C determines whether each port C pin is an input or an output. Writing a logic 1 to a DDRC bit enables the output buffer for the corresponding port C pin; a logic 0 disables the output buffer.

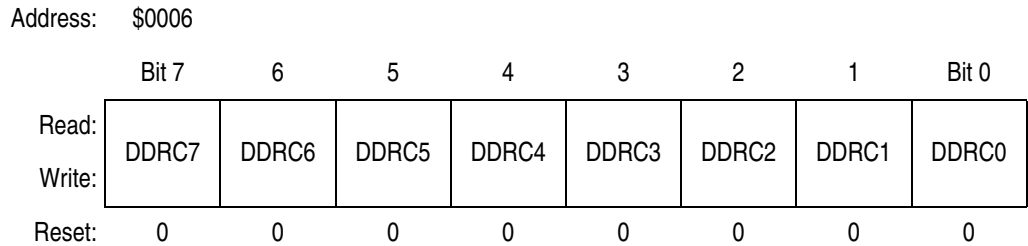


Figure 18-10. Data Direction Register C (DDRC)

DDRC[7:0] — Data Direction Register C Bits

These read/write bits control port C data direction. Reset clears DDRC[7:0], configuring all port C pins as inputs.

- 1 = Corresponding port C pin configured as output
- 0 = Corresponding port C pin configured as input

**NOTE:** Avoid glitches on port C pins by writing to the port C data register before changing data direction register C bits from 0 to 1. Figure 18-11 shows the port C I/O logic.

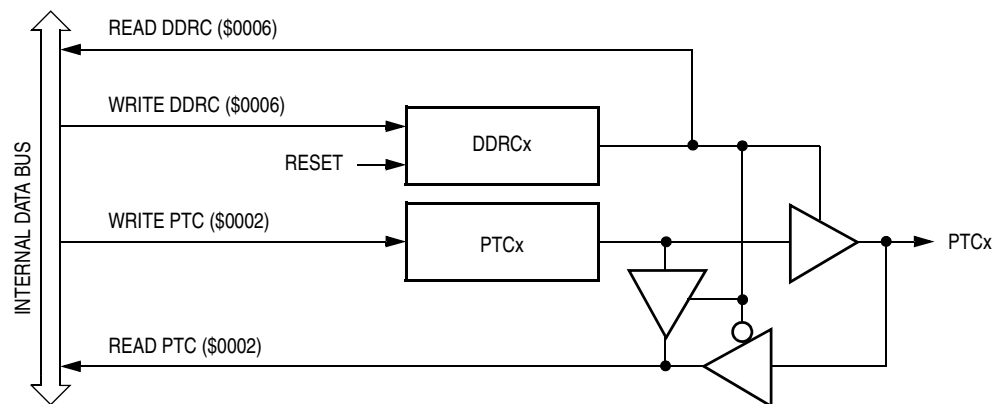


Figure 18-11. Port C I/O Circuit

When DDRCx is a logic 1, reading address \$0002 reads the PTCx data latch. When DDRCx is a logic 0, reading address \$0002 reads the voltage level on the pin. The data latch can always be written, regardless of the state of its data direction bit.

**Table 18-4** summarizes the operation of the port C pins.

**Table 18-4. Port C Pin Functions**

DDRC Bit	PTC Bit	I/O Pin Mode	Accesses to DDRC		Accesses to PTC	
			Read/Write	Read	Write	
0	X <sup>(1)</sup>	Input, Hi-Z <sup>(2)</sup>	DDRC[7:0]	Pin	PTC[7:0] <sup>(3)</sup>	
1	X	Output	DDRC[7:0]	PTC[7:0]	PTC[7:0]	

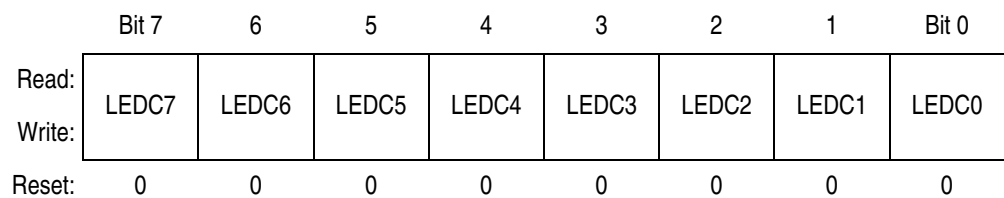
**Notes:**

1. X = don't care.
2. Hi-Z = high impedance.
3. Writing affects data register, but does not affect input.

**18.5.3 Port C LED Control Register (LEDC)**

Port-C LED control register (LEDC) controls the direct LED drive capability on PTC7–PTC0 pins. Each bit is individually configurable and requires that the data direction register, DDRC, bit be configured as an output.

Address: \$000D



**Figure 18-12. Port C LED Control Register (LEDC)**

**LEDC[7:0] — Port C LED Drive Enable Bits**

These read/write bits are software programmable to enable the direct LED drive on an output port pin.

1 = Corresponding port C pin is configured for direct LED drive, with 15mA current sinking capability

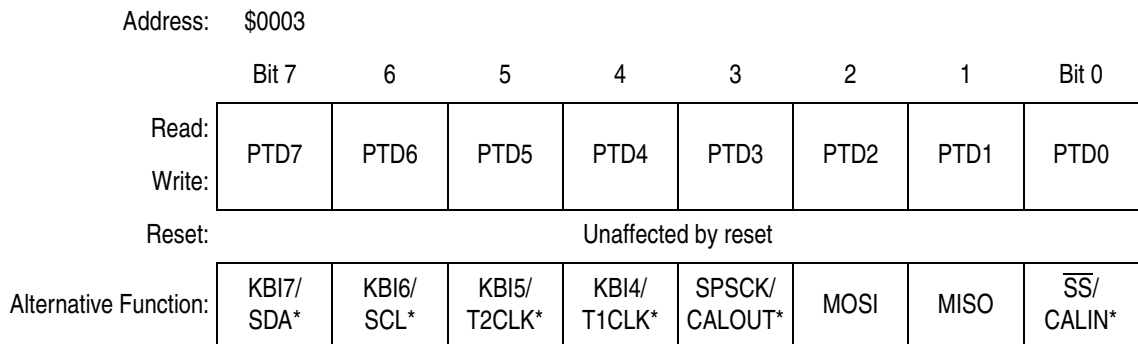
0 = Corresponding port C pin is configured for standard drive

## 18.6 Port D

Port D is an 8-bit special function port that shares its pins with the serial peripheral interface (SPI) module, keyboard interrupt module, RTC module, MMIO module, and timer modules.

### 18.6.1 Port D Data Register (PTD)

The port D data register contains a data latch for each of the eight port D pins.



\* These port pins are shared with two other modules. For each of the pins, ONLY enable ONE module at any one time to avoid pin contention.

**Figure 18-13. Port D Data Register (PTD)**

#### PTD[7:0] — Port D Data Bits

These read/write bits are software programmable. Data direction of each port D pin is under the control of the corresponding bit in data direction register D. Reset has no effect on port D data.

#### KBI[7:4] — Keyboard Interrupt Channels 7 to 4

KBI[7:4] are pins used for the keyboard interrupt input. The corresponding input, KBI[7:4], can be enabled in the keyboard interrupt enable register, KBIER. Port pins used as KBI input will override any control from the port I/O logic. See [Section 20. Keyboard Interrupt Module \(KBI\)](#).

**SDA, SCL — Multi-Master IIC Data and Clock Pins**

The SDA and SCL pins are multi-master IIC data and clock open-drain pins, enabled by setting the MMEN bit in the MMIIC control register (MMCR). Port pins used as MMIIC will override any control from the port I/O logic. See [Section 15. Multi-Master IIC Interface \(MMIIC\)](#).

**T2CLK — TIM2 Clock Input Pin**

The T2CLK pin is the external clock input for TIM2, enabled by setting the prescaler select bits, PS[2:0] to %111, in the TIM2 status and control register (T2SC). Port pin used as T2CLK will override any control from the port I/O logic. See [Section 11. Timer Interface Module \(TIM\)](#).

**T1CLK — TIM1 Clock Input Pin**

The T1CLK pin is the external clock input for TIM1, enabled by setting the prescaler select bits, PS[2:0] to %111, in the TIM1 status and control register (T1SC). Port pin used as T1CLK will override any control from the port I/O logic. See [Section 11. Timer Interface Module \(TIM\)](#).

**SPSCK, MOSI, MISO, and  $\overline{SS}$  — SPI Functional Pins**

These four pins are the SPI clock, master-output-slave-input, master-input-slave-output, and slave select pins; enabled by setting the SPI enable bit, SPE, in the SPI control register (SPCR). Port pins used as SPI will override any control from the port I/O logic. See [Section 14. Serial Peripheral Interface Module \(SPI\)](#).

**CALOUT, CALIN — RTC Calibration Pins**

The CALOUT and CALIN pins are RTC calibration pins, enabled by setting the CAL bit in the RTC calibration register (RTCCOMR). Port pins used for RTC calibration will override any control from the port I/O logic. See [Section 12. Real Time Clock \(RTC\)](#).

Input/Output (I/O) Ports

18.6.2 Data Direction Register D (DDRD)

Data direction register D determines whether each port D pin is an input or an output. Writing a logic 1 to a DDRD bit enables the output buffer for the corresponding port D pin; a logic 0 disables the output buffer.

Address: \$0007

	Bit 7	6	5	4	3	2	1	Bit 0
Read:	DDRD7	DDRD6	DDRD5	DDRD4	DDRD3	DDRD2	DDRD1	DDRD0
Write:								
Reset:	0	0	0	0	0	0	0	0

Figure 18-14. Data Direction Register D (DDRD)

DDRD[7:0] — Data Direction Register D Bits

These read/write bits control port D data direction. Reset clears DDRD[7:0], configuring all port D pins as inputs.

- 1 = Corresponding port D pin configured as output
- 0 = Corresponding port D pin configured as input

**NOTE:** Avoid glitches on port D pins by writing to the port D data register before changing data direction register D bits from 0 to 1. Figure 18-15 shows the port D I/O logic.

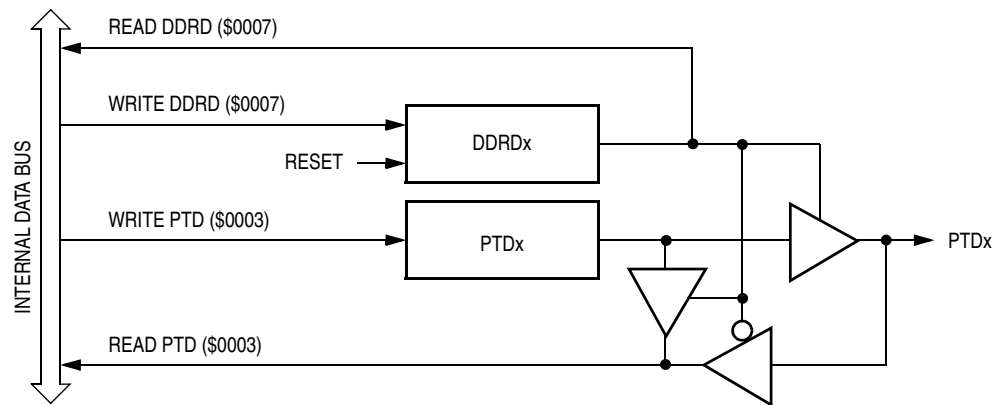


Figure 18-15. Port D I/O Circuit



When DDRDx is a logic 1, reading address \$0003 reads the PTDx data latch. When DDRDx is a logic 0, reading address \$0003 reads the voltage level on the pin. The data latch can always be written, regardless of the state of its data direction bit.

**Table 18-5** summarizes the operation of the port D pins.

**Table 18-5. Port D Pin Functions**

DDRD Bit	PTD Bit	I/O Pin Mode	Accesses to DDRD		Accesses to PTD	
			Read/Write	Read	Write	
0	X <sup>(1)</sup>	Input, Hi-Z <sup>(2)</sup>	DDRD[7:0]	Pin	PTD[7:0] <sup>(3)</sup>	
1	X	Output	DDRD[7:0]	PTD[7:0]	PTD[7:0]	

**Notes:**

1. X = don't care.
2. Hi-Z = high impedance.
3. Writing affects data register, but does not affect input.

## 18.7 Port E

Port E is an 8-bit special function port that shares all of its port pins with the liquid crystal display (LCD) driver module.

Port pins PTE0–PTE7 can be configured for direct LED drive.

### 18.7.1 Port E Data Register (PTE)

The port E data register contains a data latch for each of the eight port E pins.

Address: \$0008

	Bit 7	6	5	4	3	2	1	Bit 0
Read:	PTE7	PTE6	PTE5	PTE4	PTE3	PTE2	PTE1	PTE0
Write:								
Reset:	Unaffected by reset							
Alternative Function:	FP18	FP17	FP16	FP15	FP14	FP13	FP12	FP11
Additional Function:	LED drive	LED drive	LED drive	LED drive	LED drive	LED drive	LED drive	LED drive

**Figure 18-16. Port E Data Register (PTE)**

#### PTE[7:0] — Port E Data Bits

These read/write bits are software programmable. Data direction of each port E pin is under the control of the corresponding bit in data direction register E. Reset has no effect on port E data.

#### FP[18:11] — LCD Driver Frontplanes 18–11

FP[18:11] are pins used for the frontplane output of the LCD driver module. The enable bit, PEE, in the CONFIG2 register, determines whether the PTE7/FP18–PTE0/FP11 pins are LCD frontplane driver pins or general-purpose I/O pins. See [Section 17. Liquid Crystal Display \(LCD\) Driver](#).

#### LED drive — Direct LED Drive Pins

PTE0–PTE7 pins can be configured for direct LED drive. See [18.7.3 Port E LED Control Register \(LEDE\)](#).

18.7.2 Data Direction Register E (DDRE)

Data direction register E determines whether each port E pin is an input or an output. Writing a logic 1 to a DDRE bit enables the output buffer for the corresponding port E pin; a logic 0 disables the output buffer.

Address: \$0009

	Bit 7	6	5	4	3	2	1	Bit 0
Read:	DDRE7	DDRE6	DDRE5	DDRE4	DDRE3	DDRE2	DDRE1	DDRE0
Write:								
Reset:	0	0	0	0	0	0	0	0

Figure 18-17. Data Direction Register E (DDRE)

DDRE[7:0] — Data Direction Register E Bits

These read/write bits control port E data direction. Reset clears DDRE[7:0], configuring all port E pins as inputs.

- 1 = Corresponding port E pin configured as output
- 0 = Corresponding port E pin configured as input

**NOTE:** Avoid glitches on port E pins by writing to the port E data register before changing data direction register E bits from 0 to 1. Figure 18-18 shows the port E I/O logic.

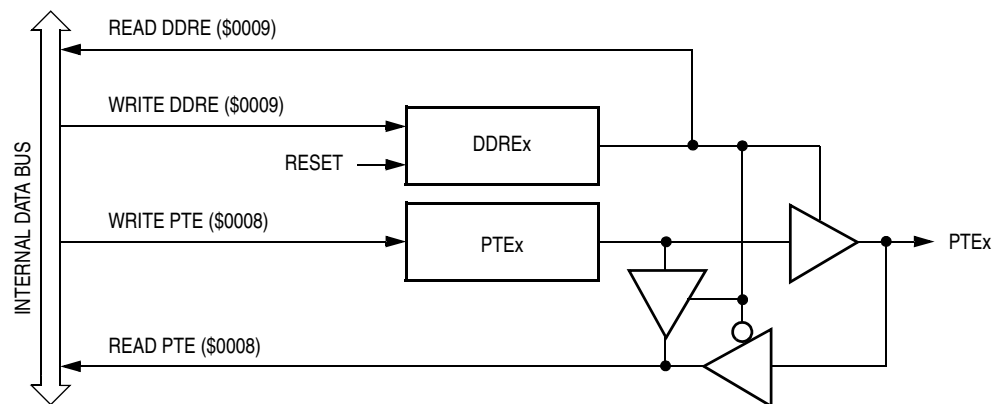


Figure 18-18. Port E I/O Circuit

When DDREx is a logic 1, reading address \$0008 reads the PTE<sub>x</sub> data latch. When DDREx is a logic 0, reading address \$0008 reads the voltage level on the pin. The data latch can always be written, regardless of the state of its data direction bit.

Table 18-6 summarizes the operation of the port E pins.

Table 18-6. Port E Pin Functions

DDRE Bit	PTE Bit	I/O Pin Mode	Accesses to DDRE		Accesses to PTE	
			Read/Write	Read	Write	
0	X <sup>(1)</sup>	Input, Hi-Z <sup>(2)</sup>	DDRE[7:0]	Pin	PTE[7:0] <sup>(3)</sup>	
1	X	Output	DDRE[7:0]	PTE[7:0]	PTE[7:0]	

Notes:

1. X = don't care; except.
2. Hi-Z = high impedance.
3. Writing affects data register, but does not affect input.

18.7.3 Port E LED Control Register (LEDE)

The port-E LED control register (LEDE) controls the direct LED drive capability on PTE7–PTE0 pins. Each bit is individually configurable and requires that the data direction register, DDRE, bit be configured as an output.

Address: \$000E

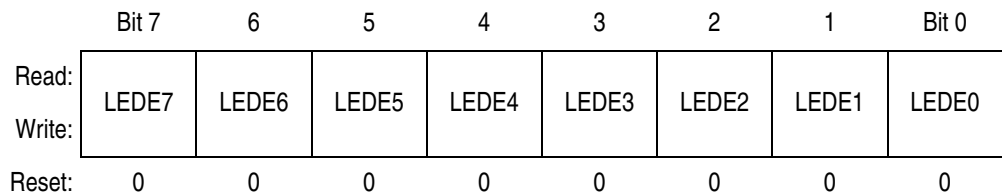


Figure 18-19. Port E LED Control Register (LEDE)

LEDE[7:0] — Port E LED Drive Enable Bits

These read/write bits are software programmable to enable the direct LED drive on an output port pin.

1 = Corresponding port E pin is configured for direct LED drive, with 15mA current sinking capability

0 = Corresponding port E pin is configured for standard drive

## 18.8 Port F

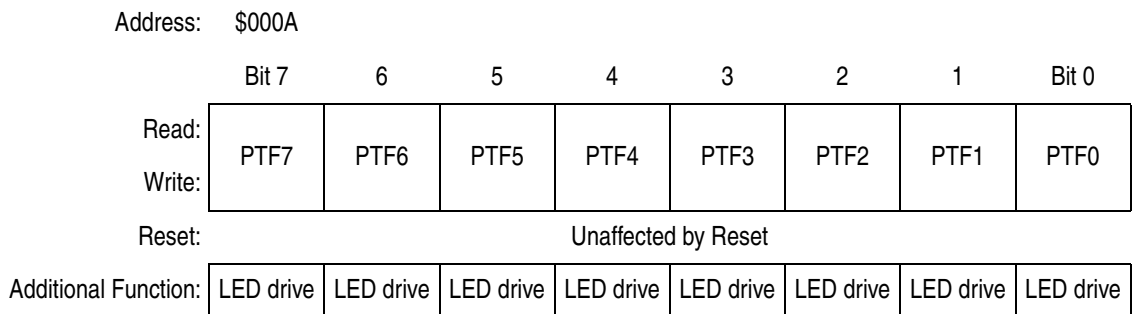
Port F is an 8-bit general-purpose I/O port.

Port pins PTF0–PTF7 can be configured for direct LED drive.

**NOTE:** PTF0–PTF7 are not available in the 64-pin packages.

### 18.8.1 Port F Data Register (PTF)

The port F data register contains a data latch for each of the eight port F pins.



**Figure 18-20. Port F Data Register (PTF)**

#### PTF[7:0] — Port F Data Bits

These read/write bits are software programmable. Data direction of each port F pin is under the control of the corresponding bit in data direction register F. Reset has no effect on port F data.

#### LED drive — Direct LED Drive Pins

PTF0–PTF7 pins can be configured for direct LED drive. See [18.8.3 Port F LED Control Register \(LEDF\)](#).

18.8.2 Data Direction Register F (DDRF)

Data direction register F determines whether each port F pin is an input or an output. Writing a logic 1 to a DDRF bit enables the output buffer for the corresponding port F pin; a logic 0 disables the output buffer.

**NOTE:** For those devices packaged in a 64-pin package, PTF0–PTF7 are connected to ground internally. DDRF0–DDRF7 should be set to a 0 to configure PTF0–PTF7 as inputs.

Address: \$000B

	Bit 7	6	5	4	3	2	1	Bit 0
Read:	DDRF7	DDRF6	DDRF5	DDRF4	DDRF3	DDRF2	DDRF1	DDRF0
Write:								
Reset:	0	0	0	0	0	0	0	0

Figure 18-21. Data Direction Register F (DDRF)

DDRF[7:0] — Data Direction Register F Bits

These read/write bits control port F data direction. Reset clears DDRF[7:0], configuring all port F pins as inputs.

- 1 = Corresponding port F pin configured as output
- 0 = Corresponding port F pin configured as input

**NOTE:** Avoid glitches on port F pins by writing to the port F data register before changing data direction register F bits from 0 to 1. Figure 18-22 shows the port F I/O logic.

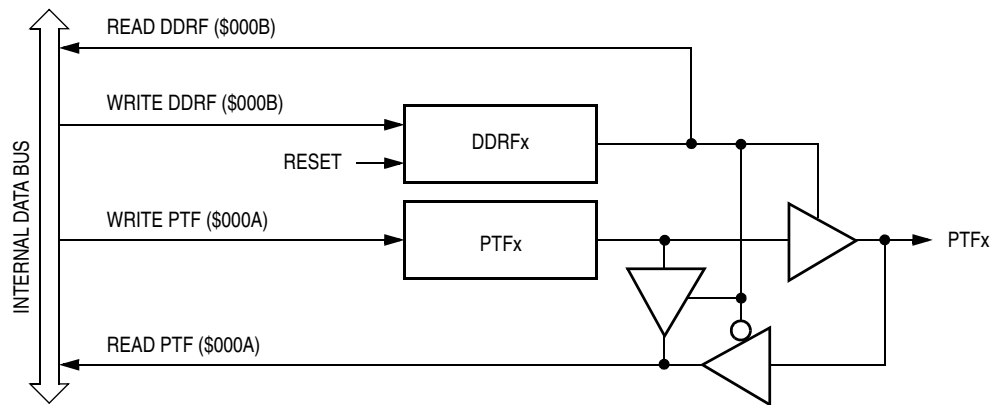


Figure 18-22. Port F I/O Circuit

When DDRFx is a logic 1, reading address \$000A reads the PTFx data latch. When DDRFx is a logic 0, reading address \$000A reads the voltage level on the pin. The data latch can always be written, regardless of the state of its data direction bit.

**Table 18-7** summarizes the operation of the port F pins.

**Table 18-7. Port F Pin Functions**

DDRF Bit	PTF Bit	I/O Pin Mode	Accesses to DDRF		Accesses to PTF	
			Read/Write	Read	Write	
0	X <sup>(1)</sup>	Input, Hi-Z <sup>(2)</sup>	DDRF[7:0]	Pin	PTF[7:0] <sup>(3)</sup>	
1	X	Output	DDRF[7:0]	PTF[7:0]	PTF[7:0]	

**Notes:**

1. X = don't care; except.
2. Hi-Z = high impedance.
3. Writing affects data register, but does not affect input.

**18.8.3 Port F LED Control Register (LEDF)**

Port-F LED control register (LEDF) controls the direct LED drive capability on PTF7–PTF0 pins. Each bit is individually configurable and requires that the data direction register, DDRF, bit be configured as an output.

Address: \$000F

	Bit 7	6	5	4	3	2	1	Bit 0
Read:	LEDF7	LEDF6	LEDF5	LEDF4	LEDF3	LEDF2	LEDF1	LEDF0
Write:								
Reset:	0	0	0	0	0	0	0	0

**Figure 18-23. Port F LED Control Register (LEDF)**

**LEDF[7:0] — Port F LED Drive Enable Bits**

These read/write bits are software programmable to enable the direct LED drive on an output port pin.

- 1 = Corresponding port F pin is configured for direct LED drive, with 15mA current sinking capability
- 0 = Corresponding port F pin is configured for standard drive





## Section 19. External Interrupt (IRQ)

### 19.1 Contents

19.2	Introduction .....	401
19.3	Features .....	401
19.4	Functional Description .....	402
19.4.1	$\overline{\text{IRQ}}$ Pin .....	404
19.5	IRQ Module During Break Interrupts .....	405
19.6	IRQ Status and Control Register (INTSCR) .....	405

### 19.2 Introduction

The external interrupt (IRQ) module provides a maskable interrupt input.

### 19.3 Features

Features of the IRQ module include the following:

- A dedicated external interrupt pin ( $\overline{\text{IRQ}}$ )
- IRQ interrupt control bits
- Hysteresis buffer
- Programmable edge-only or edge and level interrupt sensitivity
- Automatic interrupt acknowledge
- Internal pullup resistor

## 19.4 Functional Description

A logic 0 applied to the external interrupt pin can latch a CPU interrupt request. **Figure 19-1** shows the structure of the IRQ module.

Interrupt signals on the  $\overline{\text{IRQ}}$  pin are latched into the IRQ latch. An interrupt latch remains set until one of the following actions occurs:

- Vector fetch — A vector fetch automatically generates an interrupt acknowledge signal that clears the IRQ latch.
- Software clear — Software can clear the interrupt latch by writing to the acknowledge bit in the interrupt status and control register (INTSCR). Writing a logic 1 to the ACK bit clears the IRQ latch.
- Reset — A reset automatically clears the interrupt latch.

The external interrupt pin is falling-edge-triggered and is software-configurable to be either falling-edge or low-level-triggered. The MODE bit in the INTSCR controls the triggering sensitivity of the  $\overline{\text{IRQ}}$  pin.

When the interrupt pin is edge-triggered only, the CPU interrupt request remains set until a vector fetch, software clear, or reset occurs.

When the interrupt pin is both falling-edge and low-level-triggered, the CPU interrupt request remains set until both of the following occur:

- Vector fetch or software clear
- Return of the interrupt pin to logic 1

The vector fetch or software clear may occur before or after the interrupt pin returns to logic 1. As long as the pin is low, the interrupt request remains pending. A reset will clear the latch and the MODE control bit, thereby clearing the interrupt even if the pin stays low.

When set, the IMASK bit in the INTSCR mask all external interrupt requests. A latched interrupt request is not presented to the interrupt priority logic unless the IMASK bit is clear.

**NOTE:** *The interrupt mask (I) in the condition code register (CCR) masks all interrupt requests, including external interrupt requests.*

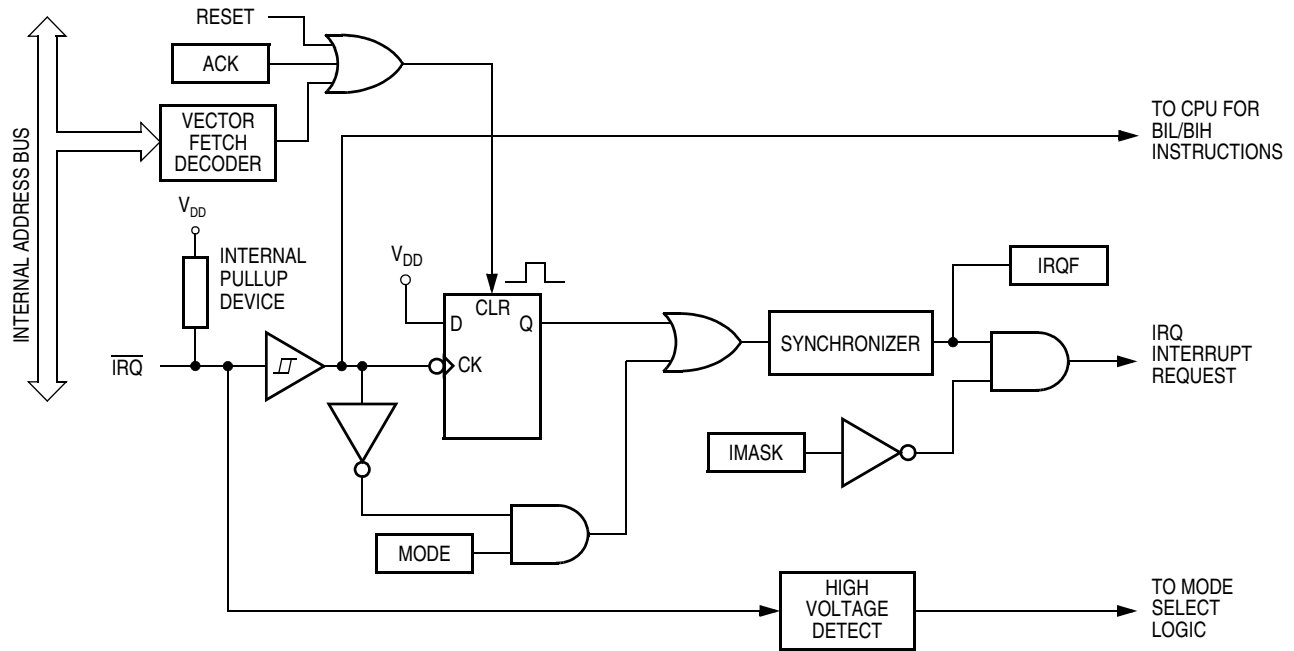


Figure 19-1. IRQ Module Block Diagram

Addr.	Register Name	Bit 7	6	5	4	3	2	1	Bit 0	
\$001E	IRQ Status and Control Register (INTSCR)	Read:	0	0	0	0	IRQF	0	IMASK	MODE
		Write:						ACK		
		Reset:	0	0	0	0	0	0	0	0

= Unimplemented

Figure 19-2. IRQ I/O Port Register Summary

19.4.1  $\overline{\text{IRQ}}$  Pin

A logic 0 on the  $\overline{\text{IRQ}}$  pin can latch an interrupt request into the IRQ latch. A vector fetch, software clear, or reset clears the IRQ latch.

If the MODE bit is set, the  $\overline{\text{IRQ}}$  pin is both falling-edge-sensitive and low-level-sensitive. With MODE set, both of the following actions must occur to clear IRQ:

- Vector fetch or software clear — A vector fetch generates an interrupt acknowledge signal to clear the latch. Software may generate the interrupt acknowledge signal by writing a logic 1 to the ACK bit in the interrupt status and control register (INTSCR). The ACK bit is useful in applications that poll the  $\overline{\text{IRQ}}$  pin and require software to clear the IRQ latch. Writing to the ACK bit prior to leaving an interrupt service routine can also prevent spurious interrupts due to noise. Setting ACK does not affect subsequent transitions on the  $\overline{\text{IRQ}}$  pin. A falling edge that occurs after writing to the ACK bit latches another interrupt request. If the IRQ mask bit, IMASK, is clear, the CPU loads the program counter with the vector address at locations \$FFFA and \$FFFB.
- Return of the  $\overline{\text{IRQ}}$  pin to logic 1 — As long as the  $\overline{\text{IRQ}}$  pin is at logic 0, IRQ remains active.

The vector fetch or software clear and the return of the  $\overline{\text{IRQ}}$  pin to logic 1 may occur in any order. The interrupt request remains pending as long as the  $\overline{\text{IRQ}}$  pin is at logic 0. A reset will clear the latch and the MODE control bit, thereby clearing the interrupt even if the pin stays low.

If the MODE bit is clear, the  $\overline{\text{IRQ}}$  pin is falling-edge-sensitive only. With MODE clear, a vector fetch or software clear immediately clears the IRQ latch.

The IRQF bit in the INTSCR register can be used to check for pending interrupts. The IRQF bit is not affected by the IMASK bit, which makes it useful in applications where polling is preferred.

Use the BIH or BIL instruction to read the logic level on the  $\overline{\text{IRQ}}$  pin.

**NOTE:** *When using the level-sensitive interrupt trigger, avoid false interrupts by masking interrupt requests in the interrupt routine.*

## 19.5 IRQ Module During Break Interrupts

The system integration module (SIM) controls whether the IRQ latch can be cleared during the break state. The BCFE bit in the break flag control register (BFCR) enables software to clear the latches during the break state. (See [Section 23. Break Module \(BRK\)](#).)

To allow software to clear the IRQ latch during a break interrupt, write a logic 1 to the BCFE bit. If a latch is cleared during the break state, it remains cleared when the MCU exits the break state.

To protect the latches during the break state, write a logic 0 to the BCFE bit. With BCFE at logic 0 (its default state), writing to the ACK bit in the IRQ status and control register during the break state has no effect on the IRQ latch.

## 19.6 IRQ Status and Control Register (INTSCR)

The IRQ status and control register (INTSCR) controls and monitors operation of the IRQ module. The INTSCR has the following functions:

- Shows the state of the IRQ flag
- Clears the IRQ latch
- Masks IRQ and interrupt request
- Controls triggering sensitivity of the  $\overline{\text{IRQ}}$  interrupt pin

External Interrupt (IRQ)

Address: \$001E

	Bit 7	6	5	4	3	2	1	Bit 0
Read:	0	0	0	0	IRQF	0	IMASK	MODE
Write:						ACK		
Reset:	0	0	0	0	0	0	0	0

= Unimplemented

**Figure 19-3. IRQ Status and Control Register (INTSCR)**

**IRQF — IRQ Flag Bit**

This read-only status bit is high when the IRQ interrupt is pending.

1 =  $\overline{\text{IRQ}}$  interrupt pending

0 =  $\overline{\text{IRQ}}$  interrupt not pending

**ACK — IRQ Interrupt Request Acknowledge Bit**

Writing a logic 1 to this write-only bit clears the IRQ latch. ACK always reads as logic 0. Reset clears ACK.

**IMASK — IRQ Interrupt Mask Bit**

Writing a logic 1 to this read/write bit disables IRQ interrupt requests. Reset clears IMASK.

1 = IRQ interrupt requests disabled

0 = IRQ interrupt requests enabled

**MODE — IRQ Edge/Level Select Bit**

This read/write bit controls the triggering sensitivity of the  $\overline{\text{IRQ}}$  pin. Reset clears MODE.

1 =  $\overline{\text{IRQ}}$  interrupt requests on falling edges and low levels

0 =  $\overline{\text{IRQ}}$  interrupt requests on falling edges only

## Section 20. Keyboard Interrupt Module (KBI)

### 20.1 Contents

20.2	Introduction . . . . .	407
20.3	Features . . . . .	408
20.4	I/O Pins . . . . .	408
20.5	Functional Description . . . . .	409
20.5.1	Keyboard Initialization . . . . .	411
20.6	Keyboard Interrupt Registers . . . . .	412
20.6.1	Keyboard Status and Control Register . . . . .	412
20.6.2	Keyboard Interrupt Enable Register . . . . .	413
20.7	Low-Power Modes . . . . .	414
20.7.1	Wait Mode . . . . .	414
20.7.2	Stop Mode . . . . .	414
20.8	Keyboard Module During Break Interrupts . . . . .	414

### 20.2 Introduction

The keyboard interrupt module (KBI) provides eight independently maskable external interrupts which are accessible via PTA0–PTA3 and PTD4–PTD7. When a port pin is enabled for keyboard interrupt function (except PTD6 and PTD7), an internal 30kΩ pullup device is also enabled on the pin.

**NOTE:** *PTD6/KBI6/SCL–PTD7/KBI7/SDA pins do not have internal pullup devices. These two pins are open-drain when configured as outputs. User should connect pullup devices when using these two pins for KBI function.*

Keyboard Interrupt Module (KBI)

20.3 Features

Features of the keyboard interrupt module include the following:

- Eight keyboard interrupt pins with pullup devices
- Separate keyboard interrupt enable bits and one keyboard interrupt mask
- Programmable edge-only or edge- and level- interrupt sensitivity
- Exit from low-power modes

Addr.	Register Name	Bit 7	6	5	4	3	2	1	Bit 0	
\$001B	Keyboard Status and Control Register (KBSCR)	Read:	0	0	0	0	KEYF	0	IMASKK	MODEK
		Write:						ACKK		
		Reset:	0	0	0	0	0	0	0	0
\$001C	Keyboard Interrupt Enable Register (KBIER)	Read:	KBIE7	KBIE6	KBIE5	KBIE4	KBIE3	KBIE2	KBIE1	KBIE0
		Write:								
		Reset:	0	0	0	0	0	0	0	0

= Unimplemented

Figure 20-1. KBI I/O Register Summary

20.4 I/O Pins

The eight keyboard interrupt pins are shared with standard port I/O pins. The full name of the KBI pins are listed in Table 20-1. The generic pin name appear in the text that follows.

Table 20-1. Pin Name Conventions

KBI Generic Pin Name	Full MCU Pin Name	Pin Selected for KBI Function by KBIEx Bit in KBIER
KBIO–KBI3	PTA0/KBI0–PTA3/KBI3	KBIE0–KBIE3
KBI4	PTD4/KBI4/T1CLK <sup>(1)</sup>	KBIE4
KBI5	PTD5/KBI5/T2CLK <sup>(1)</sup>	KBIE5
KBI6	PTD6/KBI6/SCL <sup>(1)</sup>	KBIE6
KBI7	PTD7/KBI7/SDA <sup>(1)</sup>	KBIE7

Notes:

1. Do not enable the KBI function if the pin is used for TIM / MMIC function.



20.5 Functional Description

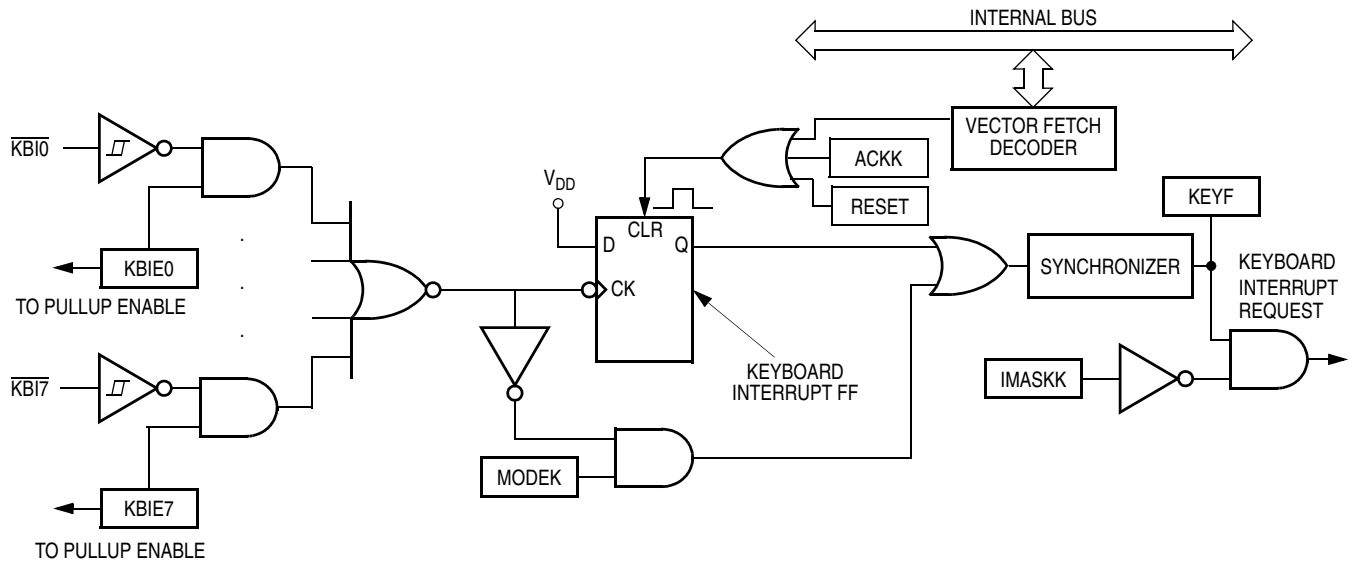


Figure 20-2. Keyboard Interrupt Block Diagram

Writing to the KBIE7–KBIE0 bits in the keyboard interrupt enable register independently enables or disables a port A or port D pin as a keyboard interrupt pin. Enabling a keyboard interrupt pin in port A or port D also enables its internal pullup device. A logic 0 applied to an enabled keyboard interrupt pin latches a keyboard interrupt request.

A keyboard interrupt is latched when one or more keyboard pins goes low after all were high. The MODEK bit in the keyboard status and control register controls the triggering mode of the keyboard interrupt.

- If the keyboard interrupt is edge-sensitive only, a falling edge on a keyboard pin does not latch an interrupt request if another keyboard pin is already low. To prevent losing an interrupt request on one pin because another pin is still low, software can disable the latter pin while it is low.
- If the keyboard interrupt is falling edge- and low level-sensitive, an interrupt request is present as long as any keyboard pin is low.

If the MODEK bit is set, the keyboard interrupt pins are both falling edge- and low level-sensitive, and both of the following actions must occur to clear a keyboard interrupt request:

- Vector fetch or software clear — A vector fetch generates an interrupt acknowledge signal to clear the interrupt request. Software may generate the interrupt acknowledge signal by writing a logic 1 to the ACKK bit in the keyboard status and control register KBSCR. The ACKK bit is useful in applications that poll the keyboard interrupt pins and require software to clear the keyboard interrupt request. Writing to the ACKK bit prior to leaving an interrupt service routine can also prevent spurious interrupts due to noise. Setting ACKK does not affect subsequent transitions on the keyboard interrupt pins. A falling edge that occurs after writing to the ACKK bit latches another interrupt request. If the keyboard interrupt mask bit, IMASKK, is clear, the CPU loads the program counter with the vector address at locations \$FFDC and \$FFDD.
- Return of all enabled keyboard interrupt pins to logic 1 — As long as any enabled keyboard interrupt pin is at logic 0, the keyboard interrupt remains set.

The vector fetch or software clear and the return of all enabled keyboard interrupt pins to logic 1 may occur in any order.

If the MODEK bit is clear, the keyboard interrupt pin is falling-edge-sensitive only. With MODEK clear, a vector fetch or software clear immediately clears the keyboard interrupt request.

Reset clears the keyboard interrupt request and the MODEK bit, clearing the interrupt request even if a keyboard interrupt pin stays at logic 0.

The keyboard flag bit (KEYF) in the keyboard status and control register can be used to see if a pending interrupt exists. The KEYF bit is not affected by the keyboard interrupt mask bit (IMASKK) which makes it useful in applications where polling is preferred.

To determine the logic level on a keyboard interrupt pin, use the data direction register to configure the pin as an input and read the data register.

**NOTE:** *Setting a keyboard interrupt enable bit (KBIE<sub>x</sub>) forces the corresponding keyboard interrupt pin to be an input, overriding the data direction register. However, the data direction register bit must be a logic 0 for software to read the pin.*

### 20.5.1 Keyboard Initialization

When a keyboard interrupt pin is enabled, it takes time for the internal pullup to reach a logic 1. Therefore a false interrupt can occur as soon as the pin is enabled.

To prevent a false interrupt on keyboard initialization:

1. Mask keyboard interrupts by setting the IMASKK bit in the keyboard status and control register.
2. Enable the KBI pins by setting the appropriate KBIE<sub>x</sub> bits in the keyboard interrupt enable register.
3. Write to the ACKK bit in the keyboard status and control register to clear any false interrupts.
4. Clear the IMASKK bit.

An interrupt signal on an edge-triggered pin can be acknowledged immediately after enabling the pin. An interrupt signal on an edge- and level-triggered interrupt pin must be acknowledged after a delay that depends on the external load.

Another way to avoid a false interrupt:

1. Configure the keyboard pins as outputs by setting the appropriate DDR bits in data direction register.
2. Write logic 1s to the appropriate data register bits.
3. Enable the KBI pins by setting the appropriate KBIE<sub>x</sub> bits in the keyboard interrupt enable register.

## 20.6 Keyboard Interrupt Registers

Two registers control the operation of the keyboard interrupt module:


- Keyboard status and control register (KBSCR)
- Keyboard interrupt enable register (KBIER)

### 20.6.1 Keyboard Status and Control Register

- Flags keyboard interrupt requests
- Acknowledges keyboard interrupt requests
- Masks keyboard interrupt requests
- Controls keyboard interrupt triggering sensitivity

Address: \$001B

	Bit 7	6	5	4	3	2	1	Bit 0
Read:	0	0	0	0	KEYF	0	IMASKK	MODEK
Write:						ACKK		
Reset:	0	0	0	0	0	0	0	0

 = Unimplemented

**Figure 20-3. Keyboard Status and Control Register (KBSCR)**

**KEYF** — Keyboard Flag Bit

This read-only bit is set when a keyboard interrupt is pending.

Reset clears the KEYF bit.

1 = Keyboard interrupt pending

0 = No keyboard interrupt pending

**ACKK** — Keyboard Acknowledge Bit

Writing a logic 1 to this write-only bit clears the keyboard interrupt request. ACKK always reads as logic 0. Reset clears ACKK.

**IMASKK — Keyboard Interrupt Mask Bit**

Writing a logic 1 to this read/write bit prevents the output of the keyboard interrupt mask from generating interrupt requests. Reset clears the IMASKK bit.

- 1 = Keyboard interrupt requests masked
- 0 = Keyboard interrupt requests not masked

**MODEK — Keyboard Triggering Sensitivity Bit**

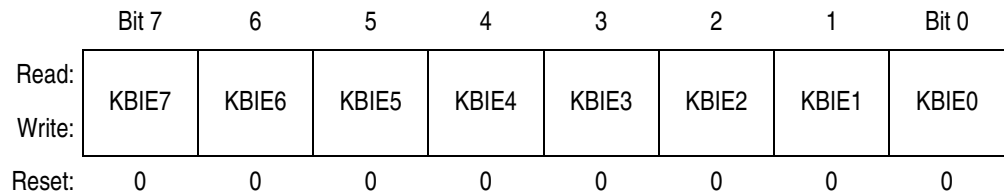
This read/write bit controls the triggering sensitivity of the keyboard interrupt pins. Reset clears MODEK.

- 1 = Keyboard interrupt requests on falling edges and low levels
- 0 = Keyboard interrupt requests on falling edges only

**20.6.2 Keyboard Interrupt Enable Register**

The keyboard interrupt enable register individually enables or disables the PTA0/KBI0–PTA3/KBI3 and PTD4/KBI4–PTD7/KBI7 pins to operate as a keyboard interrupt pin.

Address: \$001C



**Figure 20-4. Keyboard Interrupt Enable Register (KBIER)**

**KBIE7–KBIE0 — Keyboard Interrupt Enable Bits**

Each of these read/write bits enables the corresponding keyboard interrupt pin to latch interrupt requests. Reset clears the keyboard interrupt enable register.

- 1 = KBIE pin enabled as keyboard interrupt pin
- 0 = KBIE pin not enabled as keyboard interrupt pin

**NOTE:** *KBIE5–KBIE0 pin has an internal pullup device when KBIE<sub>x</sub> is set. KBIE7–KBIE6 pin does not have an internal pullup device.*

## 20.7 Low-Power Modes

The WAIT and STOP instructions put the MCU in low power-consumption standby modes.

### 20.7.1 Wait Mode

The keyboard interrupt module remains active in wait mode. Clearing the IMASKK bit in the keyboard status and control register enables keyboard interrupt requests to bring the MCU out of wait mode.

### 20.7.2 Stop Mode

The keyboard interrupt module remains active in stop mode. Clearing the IMASKK bit in the keyboard status and control register enables keyboard interrupt requests to bring the MCU out of stop mode.

## 20.8 Keyboard Module During Break Interrupts

The system integration module (SIM) controls whether the keyboard interrupt latch can be cleared during the break state. The BCFE bit in the SIM break flag control register (BFCR) enables software to clear status bits during the break state.

To allow software to clear the keyboard interrupt latch during a break interrupt, write a logic 1 to the BCFE bit. If a latch is cleared during the break state, it remains cleared when the MCU exits the break state.

To protect the latch during the break state, write a logic 0 to the BCFE bit. With BCFE at logic 0 (its default state), writing to the keyboard acknowledge bit (ACKK) in the keyboard status and control register during the break state has no effect.

## Section 21. Computer Operating Properly (COP)

### 21.1 Contents

21.2	Introduction	415
21.3	Functional Description	416
21.4	I/O Signals	417
21.4.1	ICLK	417
21.4.2	STOP Instruction	417
21.4.3	COPCTL Write	417
21.4.4	Power-On Reset	417
21.4.5	Internal Reset	418
21.4.6	Reset Vector Fetch	418
21.4.7	COPD (COP Disable)	418
21.4.8	COPRS (COP Rate Select)	418
21.5	COP Control Register	419
21.6	Interrupts	419
21.7	Monitor Mode	419
21.8	Low-Power Modes	419
21.8.1	Wait Mode	420
21.8.2	Stop Mode	420
21.9	COP Module During Break Mode	420

### 21.2 Introduction

The computer operating properly (COP) module contains a free-running counter that generates a reset if allowed to overflow. The COP module helps software recover from runaway code. Prevent a COP reset by clearing the COP counter periodically. The COP module can be disabled through the COPD bit in the configuration register 1 (CONFIG1).

21.3 Functional Description

Figure 21-1 shows the structure of the COP module.

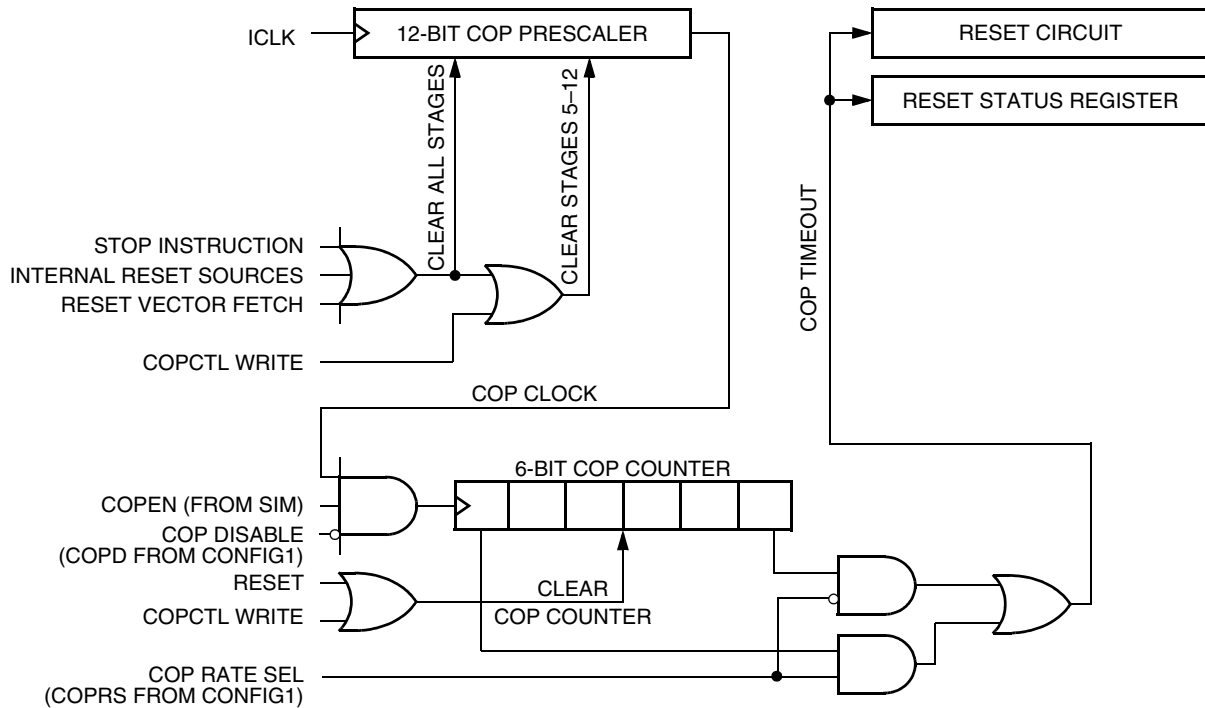


Figure 21-1. COP Block Diagram

The COP counter is a free-running 6-bit counter preceded by a 12-bit prescaler counter. If not cleared by software, the COP counter overflows and generates an asynchronous reset after  $2^{18} - 2^4$  or  $2^{13} - 2^4$  ICLK cycles, depending on the state of the COP rate select bit, COPRS, in the CONFIG1 register. With a  $2^{13} - 2^4$  ICLK cycle overflow option, a 47-kHz ICLK gives a COP timeout period of 174 ms. Writing any value to location \$FFFF before an overflow occurs prevents a COP reset by clearing the COP counter and stages 12 through 5 of the prescaler.

**NOTE:** Service the COP immediately after reset and before entering or after exiting STOP Mode to guarantee the maximum time before the first COP counter overflow.



A COP reset pulls the  $\overline{\text{RST}}$  pin low for 32 ICLK cycles and sets the COP bit in the SIM reset status register (SRSR).

In monitor mode, the COP is disabled if the  $\overline{\text{RST}}$  pin or the  $\overline{\text{IRQ}}$  is held at  $V_{\text{TST}}$ . During the break state,  $V_{\text{TST}}$  on the  $\overline{\text{RST}}$  pin disables the COP.

**NOTE:** *Place COP clearing instructions in the main program and not in an interrupt subroutine. Such an interrupt subroutine could keep the COP from generating a reset even while the main program is not working properly.*

## 21.4 I/O Signals

The following paragraphs describe the signals shown in [Figure 21-1](#).

### 21.4.1 ICLK

ICLK is the internal oscillator output signal. ICLK frequency is approximately equal to 47-kHz. See [Section 24. Electrical Specifications](#) for ICLK parameters.

### 21.4.2 STOP Instruction

The STOP instruction clears the COP prescaler.

### 21.4.3 COPCTL Write

Writing any value to the COP control register (COPCTL) (see [21.5 COP Control Register](#)) clears the COP counter and clears bits 12 through 5 of the prescaler. Reading the COP control register returns the low byte of the reset vector.

### 21.4.4 Power-On Reset

The power-on reset (POR) circuit clears the COP prescaler 4096 ICLK cycles after power-up.

**Computer Operating Properly (COP)**

**21.4.5 Internal Reset**

An internal reset clears the COP prescaler and the COP counter.

**21.4.6 Reset Vector Fetch**

A reset vector fetch occurs when the vector address appears on the data bus. A reset vector fetch clears the COP prescaler.

**21.4.7 COPD (COP Disable)**

The COPD signal reflects the state of the COP disable bit (COPD) in the CONFIG1 register. (See [Figure 21-2](#) and [Section 5. Configuration Registers \(CONFIG\)](#).)

**21.4.8 COPRS (COP Rate Select)**

The COPRS signal reflects the state of the COP rate select bit (COPRS) in the CONFIG1 register.



**Figure 21-2. Configuration Register 1 (CONFIG1)**

**COPRS — COP Rate Select**

COPRS selects the COP time-out period. Reset clears COPRS.

1 = COP time out period =  $2^{13} - 2^4$  ICLK cycles

0 = COP time out period =  $2^{18} - 2^4$  ICLK cycles

**COPD — COP Disable Bit**

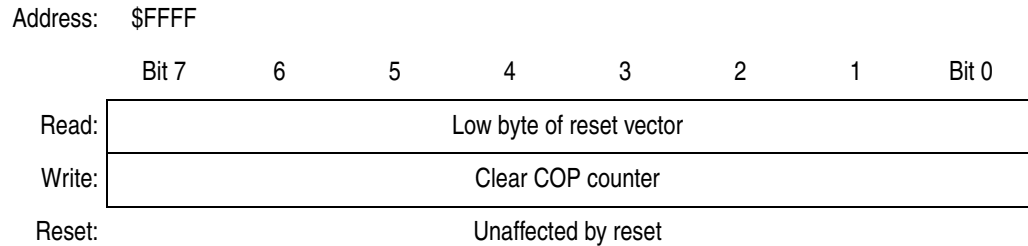
COPD disables the COP module.

1 = COP module disabled

0 = COP module enabled

## 21.5 COP Control Register

The COP control register is located at address \$FFFF and overlaps the reset vector. Writing any value to \$FFFF clears the COP counter and starts a new timeout period. Reading location \$FFFF returns the low byte of the reset vector.



**Figure 21-3. COP Control Register (COPCTL)**

## 21.6 Interrupts

The COP does not generate CPU interrupt requests.

## 21.7 Monitor Mode

When monitor mode is entered with  $V_{TST}$  on the  $\overline{IRQ}$  pin, the COP is disabled as long as  $V_{TST}$  remains on the  $\overline{IRQ}$  pin or the  $\overline{RST}$  pin. When monitor mode is entered by having blank reset vectors and not having  $V_{TST}$  on the  $\overline{IRQ}$  pin, the COP is automatically disabled until a POR occurs.

## 21.8 Low-Power Modes

The WAIT and STOP instructions put the MCU in low power-consumption standby modes.

### 21.8.1 Wait Mode

The COP remains active during wait mode. To prevent a COP reset during wait mode, periodically clear the COP counter in a CPU interrupt routine.

### 21.8.2 Stop Mode

Stop mode turns off the ICLK input to the COP and clears the COP prescaler. Service the COP immediately before entering or after exiting stop mode to ensure a full COP timeout period after entering or exiting stop mode.

To prevent inadvertently turning off the COP with a STOP instruction, a configuration option is available that disables the STOP instruction. When the STOP bit in the configuration register has the STOP instruction is disabled, execution of a STOP instruction results in an illegal opcode reset.

## 21.9 COP Module During Break Mode

The COP is disabled during a break interrupt when  $V_{TST}$  is present on the  $\overline{RST}$  pin.

## Section 22. Low-Voltage Inhibit (LVI)

### 22.1 Contents

22.2	Introduction . . . . .	421
22.3	Features . . . . .	421
22.4	Functional Description . . . . .	422
22.4.1	Polled LVI Operation . . . . .	424
22.4.2	Forced Reset Operation . . . . .	424
22.4.3	Voltage Hysteresis Protection . . . . .	424
22.4.4	LVI Trip Selection . . . . .	425
22.5	LVI Status Register . . . . .	425
22.6	Low-Power Modes . . . . .	426
22.6.1	Wait Mode . . . . .	426
22.6.2	Stop Mode . . . . .	426

### 22.2 Introduction

This section describes the low-voltage inhibit (LVI) module, which monitors the voltage on the  $V_{DD}$  pin and can force a reset when the  $V_{DD}$  voltage falls below the LVI trip falling voltage,  $V_{TRIPF}$ .

### 22.3 Features

Features of the LVI module include:

- Programmable LVI interrupt and reset
- Selectable LVI trip voltage
- Programmable stop mode operation

Low-Voltage Inhibit (LVI)

Addr.	Register Name	Bit 7	6	5	4	3	2	1	Bit 0
\$FE0F	Low-Voltage Inhibit Status Register (LVISR)	Read: LVIOUT	LVIIIE	LVIIF	0	0	0	0	0
		Write: [Unimplemented]		[Unimplemented]	LVIIACK	[Unimplemented]	[Unimplemented]	[Unimplemented]	[Unimplemented]
		Reset:	0	0	0	0	0	0	0

[Unimplemented] = Unimplemented

Figure 22-1. LVI I/O Register Summary

22.4 Functional Description

Figure 22-2 shows the structure of the LVI module.

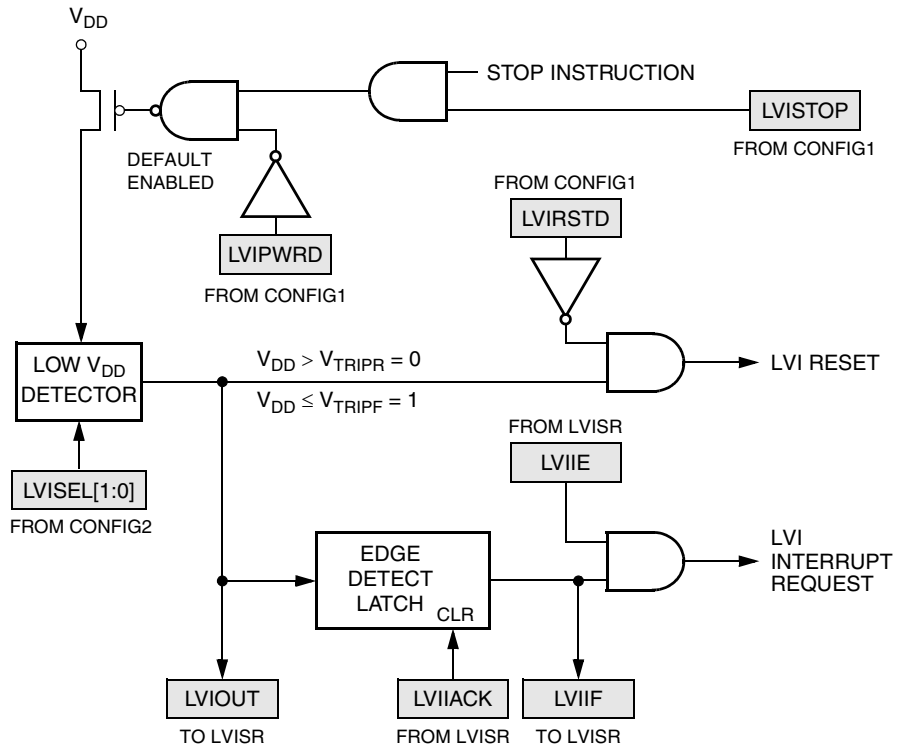


Figure 22-2. LVI Module Block Diagram

The LVI is enabled out of reset. The LVI module contains a bandgap reference circuit and comparator. Clearing the LVI power disable bit, LVIPWRD, enables the LVI to monitor  $V_{DD}$  voltage. Clearing the LVI reset disable bit, LVIRSTD, enables the LVI module to generate a reset when  $V_{DD}$  falls below a voltage,  $V_{TRIPF}$ . Setting the LVI enable in stop mode bit, LVISTOP, enables the LVI to operate in stop mode.

The LVI trip point selection bits, LVISEL[1:0], select the trip point voltage,  $V_{TRIPF}$ , to be configured for 5V or 3V operation. The actual trip points are shown in [Section 24. Electrical Specifications](#).

Setting LVI interrupt enable bit, LVIIE, enables LVI interrupts whenever the LVIOOUT bit toggles (from logic 0 to logic 1, or from logic 1 to logic 0).

**NOTE:** *After a power-on reset (POR) the LVI's default mode of operation is 3V. If a 5V system is used, the user must modified the LVISEL[1:0] bits to raise the trip point to 5V operation. Note that this must be done after every power-on reset since the default will revert back to 3V mode after each power-on reset. If the  $V_{DD}$  supply is below the 3V mode trip voltage when POR is released, the MCU will immediately go into reset. The LVI in this case will hold the MCU in reset until either  $V_{DD}$  goes above the rising 3V trip point,  $V_{TRIPR}$ , which will release reset or  $V_{DD}$  decreases to approximately 0V which will re-trigger the power-on reset.*

LVISTOP, LVIPWRD, LVIRSTD, and LVISEL[1:0] are in the configuration registers. See [Section 5. Configuration Registers \(CONFIG\)](#) for details of the LVI's configuration bits. Once an LVI reset occurs, the MCU remains in reset until  $V_{DD}$  rises above a voltage,  $V_{TRIPR}$ , which causes the MCU to exit reset. See [9.4.2.5 Low-Voltage Inhibit \(LVI\) Reset](#) for details of the interaction between the SIM and the LVI. The output of the comparator controls the state of the LVIOOUT flag in the LVI status register (LVISR). The LVIIE, LVIIF, and LVIACK bits in the LVISR control LVI interrupt functions.

An LVI reset also drives the  $\overline{RST}$  pin low to provide low-voltage protection to external peripheral devices.

### 22.4.1 Polled LVI Operation

In applications that can operate at  $V_{DD}$  levels below the  $V_{TRIPF}$  level, software can monitor  $V_{DD}$  by polling the LVIOUT bit, or by setting the LVI interrupt enable bit, LVIIIE, to enable interrupt requests. In the configuration register 1 (CONFIG1), the LVIPWRD bit must be at logic 0 to enable the LVI module, and the LVIRSTD bit must be at logic 1 to disable LVI resets.

The LVI interrupt flag, LVIIIF, is set whenever the LVIOUT bit changes state (toggles). When LVIIIF is set, a CPU interrupt request is generated if the LVIIIE is also set. In the LVI interrupt service subroutine, LVIIIF bit can be cleared by writing a logic 1 to the LVI interrupt acknowledge bit, LVIIACK.

### 22.4.2 Forced Reset Operation

In applications that require  $V_{DD}$  to remain above the  $V_{TRIPF}$  level, enabling LVI resets allows the LVI module to reset the MCU when  $V_{DD}$  falls below the  $V_{TRIPF}$  level. In the configuration register 1 (CONFIG1), the LVIPWRD and LVIRSTD bits must be at logic 0 to enable the LVI module and to enable LVI resets.

If LVIIIE is set to enable LVI interrupts when LVIRSTD is cleared, LVI reset has a higher priority over LVI interrupt. In this case, when  $V_{DD}$  falls below the  $V_{TRIPF}$  level, an LVI reset will occur, and the LVIIIE bit will be cleared.

### 22.4.3 Voltage Hysteresis Protection

Once the LVI has triggered (by having  $V_{DD}$  fall below  $V_{TRIPF}$ ), the LVI will maintain a reset condition until  $V_{DD}$  rises above the rising trip point voltage,  $V_{TRIPR}$ . This prevents a condition in which the MCU is continually entering and exiting reset if  $V_{DD}$  is approximately equal to  $V_{TRIPF}$ .  $V_{TRIPR}$  is greater than  $V_{TRIPF}$  by the hysteresis voltage,  $V_{HYS}$ .



### 22.4.4 LVI Trip Selection

The trip point selection bits, LVISEL[1:0], in the CONFIG2 register select whether the LVI is configured for 5V or 3V operation. (See [Section 5. Configuration Registers \(CONFIG\)](#).)


**NOTE:** The MCU is guaranteed to operate at a minimum supply voltage. The trip point ( $V_{TRIPF}[5V]$  or  $V_{TRIPF}[3V]$ ) may be lower than this. (See [Section 24. Electrical Specifications](#) for the actual trip point voltages.)

### 22.5 LVI Status Register

The LVI status register (LVISR) controls LVI interrupt functions and indicates if the  $V_{DD}$  voltage was detected below the  $V_{TRIPF}$  level.

Address: \$FE0F

	Bit 7	6	5	4	3	2	1	Bit 0
Read:	LVIOUT	LVIE	LVIIF	0	0	0	0	0
Write:				LVIACK				
Reset:	0	0	0	0	0	0	0	0

 = Unimplemented

**Table 22-1. LVI Status Register (LVISR)**

#### LVIOUT — LVI Output Bit

This read-only flag becomes set when the  $V_{DD}$  voltage falls below the  $V_{TRIPF}$  trip voltage (see [Table 22-2](#)). Reset clears the LVIOUT bit.

**Table 22-2. LVIOUT Bit Indication**

$V_{DD}$	LVIOUT
$V_{DD} > V_{TRIPR}$	0
$V_{DD} < V_{TRIPF}$	1
$V_{TRIPF} < V_{DD} < V_{TRIPR}$	Previous value

## LVIIIE — LVI Interrupt Enable Bit

This read/write bit enables the LVIIIF bit to generate CPU interrupt requests. Reset clears the LVIIIE bit.

- 1 = LVIIIF can generate CPU interrupt requests
- 0 = LVIIIF cannot generate CPU interrupt requests

## LVIIIF — LVI Interrupt Flag

This clearable, read-only flag is set whenever the LVIOOUT bit toggles. Reset clears the LVIIIF bit.

- 1 = LVIOOUT has toggled
- 0 = LVIOOUT has not toggled

## LVIIACK — LVI Interrupt Acknowledge Bit

Writing a logic 1 to this write-only bit clears the LVI interrupt flag, LVIIIF. LVIIACK always reads as logic 0.

- 1 = Clears LVIIIF bit
- 0 = No effect

## 22.6 Low-Power Modes

The STOP and WAIT instructions put the MCU in low power-consumption standby modes.

### 22.6.1 Wait Mode

If enabled, the LVI module remains active in wait mode. If enabled to generate resets or interrupts, the LVI module can generate a reset or an interrupt and bring the MCU out of wait mode.

### 22.6.2 Stop Mode

If enabled in stop mode (LVISTOP = 1), the LVI module remains active in stop mode. If enabled to generate resets or interrupts, the LVI module can generate a reset or an interrupt and bring the MCU out of stop mode.

**NOTE:** *If enabled to generate both resets and interrupts, there will be no LVI interrupts, as resets have a higher priority.*

## Section 23. Break Module (BRK)

### 23.1 Contents

23.2	Introduction . . . . .	427
23.3	Features . . . . .	428
23.4	Functional Description . . . . .	428
23.4.1	Flag Protection During Break Interrupts . . . . .	430
23.4.2	CPU During Break Interrupts . . . . .	430
23.4.3	TIM1 and TIM2 During Break Interrupts . . . . .	430
23.4.4	COP During Break Interrupts . . . . .	430
23.5	Low-Power Modes . . . . .	430
23.5.1	Wait Mode . . . . .	430
23.5.2	Stop Mode . . . . .	431
23.6	Break Module Registers . . . . .	431
23.6.1	Break Status and Control Register . . . . .	431
23.6.2	Break Address Registers . . . . .	432
23.6.3	SIM Break Status Register . . . . .	432
23.6.4	SIM Break Flag Control Register . . . . .	434

### 23.2 Introduction

This section describes the break module. The break module can generate a break interrupt that stops normal program flow at a defined address to enter a background program.

### 23.3 Features

Features of the break module include:

- Accessible input/output (I/O) registers during the break interrupt
- CPU-generated break interrupts
- Software-generated break interrupts
- COP disabling during break interrupts

### 23.4 Functional Description

When the internal address bus matches the value written in the break address registers, the break module issues a breakpoint signal to the CPU. The CPU then loads the instruction register with a software interrupt instruction (SWI) after completion of the current CPU instruction. The program counter vectors to \$FFFC and \$FFFD (\$FEFC and \$FEFD in monitor mode).

The following events can cause a break interrupt to occur:

- A CPU-generated address (the address in the program counter) matches the contents of the break address registers.
- Software writes a logic 1 to the BRKA bit in the break status and control register.

When a CPU-generated address matches the contents of the break address registers, the break interrupt begins after the CPU completes its current instruction. A return-from-interrupt instruction (RTI) in the break routine ends the break interrupt and returns the MCU to normal operation. [Figure 23-1](#) shows the structure of the break module.

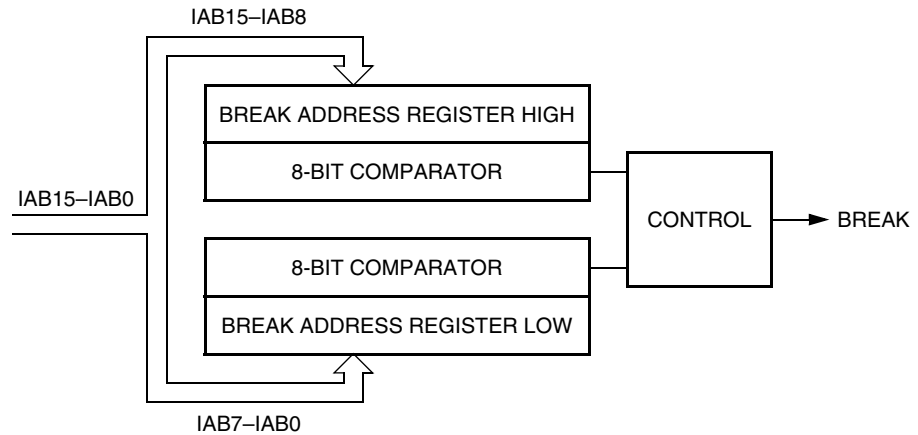


Figure 23-1. Break Module Block Diagram

Addr.	Register Name	Bit 7	6	5	4	3	2	1	Bit 0	
\$FE00	SIM Break Status Register (SBSR)	Read:	R	R	R	R	R	SBSW	R	
		Write:	R	R	R	R	R	Note	R	
		Reset:	0							
\$FE03	SIM Break Flag Control Register (SBFCR)	Read:	BCFE	R	R	R	R	R	R	
		Write:	BCFE	R	R	R	R	R	R	
		Reset:	0							
\$FE0C	Break Address Register High (BRKH)	Read:	Bit 15	14	13	12	11	10	9	Bit 8
		Write:	Bit 15	14	13	12	11	10	9	Bit 8
		Reset:	0	0	0	0	0	0	0	0
\$FE0D	Break Address Register Low (BRKL)	Read:	Bit 7	6	5	4	3	2	1	Bit 0
		Write:	Bit 7	6	5	4	3	2	1	Bit 0
		Reset:	0	0	0	0	0	0	0	0
\$FE0E	Break Status and Control Register (BRKSCR)	Read:	BRKE	BRKA	0	0	0	0	0	0
		Write:	BRKE	BRKA						
		Reset:	0	0	0	0	0	0	0	0

Note: Writing a logic 0 clears SBSW.  = Unimplemented R = Reserved

Figure 23-2. Break Module I/O Register Summary

### 23.4.1 Flag Protection During Break Interrupts

The BCFE bit in the SIM break flag control register (SBFCR) enables software to clear status bits during the break state.

### 23.4.2 CPU During Break Interrupts

The CPU starts a break interrupt by:

- Loading the instruction register with the SWI instruction
- Loading the program counter with \$FFFC and \$FFFD (\$FEFC and \$FEFD in monitor mode)

The break interrupt begins after completion of the CPU instruction in progress. If the break address register match occurs on the last cycle of a CPU instruction, the break interrupt begins immediately.

### 23.4.3 TIM1 and TIM2 During Break Interrupts

A break interrupt stops the timer counters.

### 23.4.4 COP During Break Interrupts

The COP is disabled during a break interrupt when  $V_{TST}$  is present on the  $\overline{RST}$  pin.

## 23.5 Low-Power Modes

The WAIT and STOP instructions put the MCU in low power-consumption standby modes.

### 23.5.1 Wait Mode

If enabled, the break module is active in wait mode. In the break routine, the user can subtract one from the return address on the stack if SBSW is set (see [Section 9. System Integration Module \(SIM\)](#)). Clear the SBSW bit by writing logic 0 to it.

### 23.5.2 Stop Mode

A break interrupt causes exit from stop mode and sets the SBSW bit in the break status register.

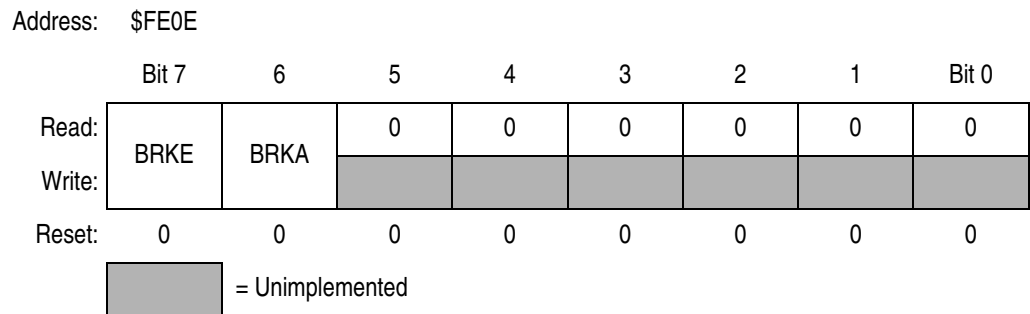
## 23.6 Break Module Registers

These registers control and monitor operation of the break module:

- Break status and control register (BRKSCR)
- Break address register high (BRKH)
- Break address register low (BRKL)
- SIM break status register (SBSR)
- SIM break flag control register (SBFCR)

### 23.6.1 Break Status and Control Register

The break status and control register (BRKSCR) contains break module enable and status bits.



**Figure 23-3. Break Status and Control Register (BRKSCR)**

#### BRKE — Break Enable Bit

This read/write bit enables breaks on break address register matches. Clear BRKE by writing a logic 0 to bit 7. Reset clears the BRKE bit.

- 1 = Breaks enabled on 16-bit address match
- 0 = Breaks disabled on 16-bit address match

BRKA — Break Active Bit

This read/write status and control bit is set when a break address match occurs. Writing a logic 1 to BRKA generates a break interrupt. Clear BRKA by writing a logic 0 to it before exiting the break routine. Reset clears the BRKA bit.

- 1 = (When read) Break address match
- 0 = (When read) No break address match

23.6.2 Break Address Registers

The break address registers (BRKH and BRKL) contain the high and low bytes of the desired breakpoint address. Reset clears the break address registers.

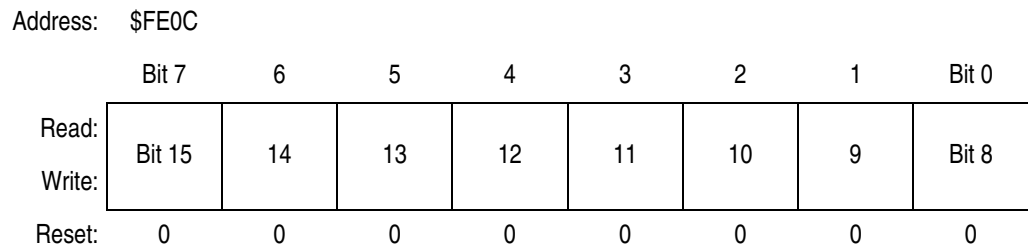


Figure 23-4. Break Address Register High (BRKH)

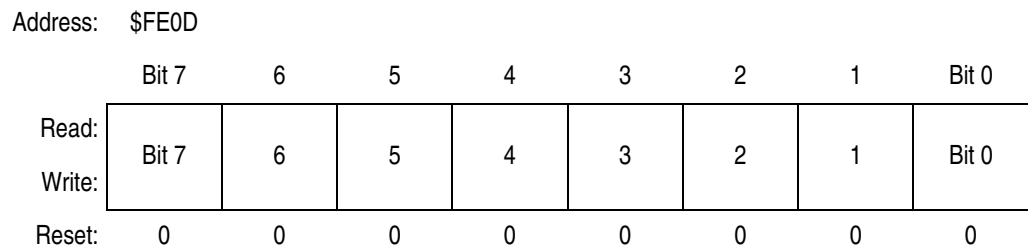
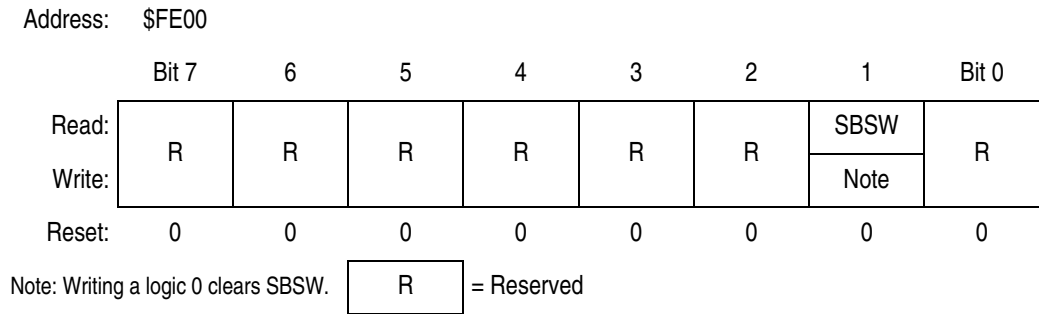


Figure 23-5. Break Address Register Low (BRKL)

23.6.3 SIM Break Status Register

The SIM break status register (SBSR) contains a flag to indicate that a break caused an exit from wait mode. The flag is useful in applications requiring a return to wait mode after exiting from a break interrupt.





**Figure 23-6. SIM Break Status Register (SBSR)**

**SBSW — Break Wait Bit**

This status bit is set when a break interrupt causes an exit from wait mode or stop mode. Clear SBSW by writing a logic 0 to it. Reset clears SBSW.

- 1 = Stop mode or wait mode was exited by break interrupt
- 0 = Stop mode or wait mode was not exited by break interrupt

SBSW can be read within the break interrupt routine. The user can modify the return address on the stack by subtracting 1 from it. The following code is an example.

```

;This code works if the H register has been pushed onto the stack in the break
;service routine software. This code should be executed at the end of the break
;service routine software.

HIBYTE EQU 5
LOBYTE EQU 6

; If not SBSW, do RTI

BRCLR SBSW,SBSR, RETURN ;See if wait mode or stop mode was exited by
;break.

TST LOBYTE,SP ;If RETURNLO is not zero,
BNE DOLO ;then just decrement low byte.
DEC HIBYTE,SP ;Else deal with high byte, too.
DOLO DEC LOBYTE,SP ;Point to WAIT/STOP opcode.
RETURN PULH ;Restore H register.
RTI
    
```

23.6.4 SIM Break Flag Control Register

The SIM break flag control register (SBFCR) contains a bit that enables software to clear status bits while the MCU is in a break state.

Address: \$FE03

	Bit 7	6	5	4	3	2	1	Bit 0
Read:	BCFE	R	R	R	R	R	R	R
Write:								
Reset:	0							

R
---

 = Reserved

Figure 23-7. SIM Break Flag Control Register (SBFCR)

BCFE — Break Clear Flag Enable Bit

This read/write bit enables software to clear status bits by accessing status registers while the MCU is in a break state. To clear status bits during the break state, the BCFE bit must be set.

- 1 = Status bits clearable during break
- 0 = Status bits not clearable during break

## Section 24. Electrical Specifications

### 24.1 Contents

24.2	Introduction . . . . .	435
24.3	Absolute Maximum Ratings . . . . .	436
24.4	Functional Operating Range . . . . .	437
24.5	Thermal Characteristics . . . . .	437
24.6	5V DC Electrical Characteristics . . . . .	438
24.7	3.3V DC Electrical Characteristics . . . . .	439
24.8	5V Control Timing . . . . .	440
24.9	3.3V Control Timing . . . . .	441
24.10	5V Oscillator Characteristics . . . . .	441
24.11	3.3V Oscillator Characteristics . . . . .	442
24.12	5V ADC Electrical Characteristics . . . . .	443
24.13	3.3V ADC Electrical Characteristics . . . . .	444
24.14	Timer Interface Module Characteristics . . . . .	445
24.15	CGM Electrical Specifications . . . . .	445
24.16	5V SPI Characteristics . . . . .	446
24.17	3.3V SPI Characteristics . . . . .	447
24.18	FLASH Memory Characteristics . . . . .	450

### 24.2 Introduction

This section contains electrical and timing specifications.

### 24.3 Absolute Maximum Ratings

Maximum ratings are the extreme limits to which the MCU can be exposed without permanently damaging it.

**NOTE:** *This device is not guaranteed to operate properly at the maximum ratings. Refer to [DC Electrical Characteristics](#) for guaranteed operating conditions.*

**Table 24-1. Absolute Maximum Ratings**

Characteristic <sup>(1)</sup>	Symbol	Value	Unit
Supply voltage	$V_{DD}$	-0.3 to +6.0	V
Input voltage All pins (except $\overline{IRQ}$ ) $\overline{IRQ}$ pin	$V_{IN}$	$V_{SS} - 0.3$ to $V_{DD} + 0.3$ $V_{SS} - 0.3$ to 8.5	V
Maximum current per pin excluding $V_{DD}$ and $V_{SS}$	I	$\pm 25$	mA
Maximum current out of $V_{SS}$	$I_{MVSS}$	100	mA
Maximum current into $V_{DD}$	$I_{MVDD}$	100	mA
Storage temperature	$T_{STG}$	-55 to +150	°C

**Notes:**

1. Voltages referenced to  $V_{SS}$ .

*This device contains circuitry to protect the inputs against damage due to high static voltages or electric fields; however, it is advised that normal precautions be taken to avoid application of any voltage higher than maximum-rated voltages to this high-impedance circuit. For proper operation, it is recommended that  $V_{IN}$  and  $V_{OUT}$  be constrained to the range  $V_{SS} \leq (V_{IN} \text{ or } V_{OUT}) \leq V_{DD}$ . Reliability of operation is enhanced if unused inputs are connected to an appropriate logic voltage level (for example, either  $V_{SS}$  or  $V_{DD}$ .)*

## 24.4 Functional Operating Range

Table 24-2. Functional Operating Range

Characteristic	Symbol	Value	Unit
Operating temperature range	$T_A$	-40 to +85	°C
Operating voltage range	$V_{DD}$	$3.3 \pm 10\%$ $5 \pm 10\%$	V

## 24.5 Thermal Characteristics

Table 24-3. Thermal Characteristics

Characteristic	Symbol	Value	Unit
Thermal resistance 64-pin LQFP 64-pin QFP 80-pin LQFP 80-pin QFP	$\theta_{JA}$	72 67 85 75	°C/W
I/O pin power dissipation	$P_{I/O}$	User determined	W
Power dissipation <sup>(1)</sup>	$P_D$	$P_D = (I_{DD} \times V_{DD}) + P_{I/O} =$ $K/(T_J + 273 \text{ °C})$	W
Constant <sup>(2)</sup>	K	$P_D \times (T_A + 273 \text{ °C})$ $+ P_D^2 \times \theta_{JA}$	W/°C
Average junction temperature	$T_J$	$T_A + (P_D \times \theta_{JA})$	°C

**Notes:**

1. Power dissipation is a function of temperature.
2. K constant unique to the device. K can be determined for a known  $T_A$  and measured  $P_D$ .  
With this value of K,  $P_D$  and  $T_J$  can be determined for any value of  $T_A$ .

24.6 5V DC Electrical Characteristics

Table 24-4. 5V DC Electrical Characteristics

Characteristic <sup>(1)</sup>	Symbol	Min	Typ <sup>(2)</sup>	Max	Unit
Output high voltage ( $I_{LOAD} = -2.0$ mA) All ports	$V_{OH}$	$V_{DD}-0.8$	—	—	V
Output low voltage ( $I_{LOAD} = 1.6$ mA) All ports ( $I_{LOAD} = 15.0$ mA) PTB0–PTB5, PTC0–PTC7, PTE0–PTE7, PTF0–PTF7	$V_{OL}$	—	—	0.4	V
Input high voltage All ports, $\overline{RST}$ , $\overline{IRQ}$ , OSC1	$V_{IH}$	$0.7 \times V_{DD}$	—	$V_{DD}$	V
Input low voltage All ports, $\overline{RST}$ , $\overline{IRQ}$ , OSC1	$V_{IL}$	$V_{SS}$	—	$0.3 \times V_{DD}$	V
$V_{DD}$ supply current Run <sup>(3)</sup> , $f_{OP} = 8$ MHz with all modules on with ADC on with ADC off Wait <sup>(4)</sup> , $f_{OP} = 8$ MHz (all modules off) Stop, $f_{OP} = 8$ kHz <sup>(5)</sup> with OSC, RTC, LCD <sup>(6)</sup> , LVI on with OSC, RTC, LCD <sup>(6)</sup> on with OSC, RTC on all modules off	$I_{DD}$	—	15 13 10.5 5	20 18 14 8	mA mA mA mA
Digital I/O ports Hi-Z leakage current All ports, $\overline{RST}$	$I_{IL}$	—	—	$\pm 10$	$\mu$ A
Input current $\overline{IRQ}$	$I_{IN}$	—	—	$\pm 1$	$\mu$ A
Capacitance Ports (as input or output)	$C_{OUT}$ $C_{IN}$	— —	— —	12 8	pF
POR re-arm voltage <sup>(7)</sup>	$V_{POR}$	0	—	100	mV
POR rise-time ramp rate <sup>(8)</sup>	$R_{POR}$	0.035	—	—	V/ms
Monitor mode entry voltage (at $\overline{IRQ}$ pin)	$V_{TST}$	$1.5 \times V_{DD}$	—	8	V
Pullup resistors <sup>(9)</sup> PTA0–PTA3 and PTD4–PTD7 as KBI0–KBI7 $\overline{RST}$ , $\overline{IRQ}$	$R_{PU1}$ $R_{PU2}$	21 21	30 30	39 39	k $\Omega$ k $\Omega$
Low-voltage inhibit, trip falling voltage	$V_{TRIPF}$	3.6	—	4.6	V
Low-voltage inhibit, trip rising voltage	$V_{TRIPR}$	3.7	—	4.7	V

**Notes:**

1.  $V_{DD} = 4.5$  to  $5.5$  Vdc,  $V_{SS} = 0$  Vdc,  $T_A = T_L$  to  $T_H$ , unless otherwise noted.
2. Typical values reflect average measurements at midpoint of voltage range,  $25^\circ\text{C}$  only.
3. Run (operating)  $I_{DD}$  measured using external square wave clock source. All inputs  $0.2$  V from rail. No dc loads. Less than  $100$  pF on all outputs.  $C_L = 20$  pF on OSC2. All ports configured as inputs. OSC2 capacitance linearly affects run  $I_{DD}$ .
4. Wait  $I_{DD}$  measured using external square wave clock source. All inputs  $0.2$  V from rail. No dc loads. Less than  $100$  pF on all outputs.  $C_L = 20$  pF on OSC2. All ports configured as inputs. OSC2 capacitance linearly affects wait  $I_{DD}$ .
5. The  $8\text{kHz}$  clock is from a  $32\text{kHz}$  external square wave clock input at OSC1, for the driving the RTC. Due to loading effects, the  $I_{DD}$  values will be larger when a  $32\text{kHz}$  crystal circuit is connected.
6. LCD driver configured for low current mode.
7. Maximum is highest voltage that POR is guaranteed.
8. If minimum  $V_{DD}$  is not reached before the internal POR reset is released,  $\overline{\text{RST}}$  must be driven low externally until minimum  $V_{DD}$  is reached.
9.  $R_{PU1}$  and  $R_{PU2}$  are measured at  $V_{DD} = 5.0\text{V}$

**24.7 3.3V DC Electrical Characteristics**

**Table 24-5. 3.3V DC Electrical Characteristics**

Characteristic <sup>(1)</sup>	Symbol	Min	Typ <sup>(2)</sup>	Max	Unit
Output high voltage ( $I_{LOAD} = -1.0$ mA) All ports	$V_{OH}$	$V_{DD}-0.4$	—	—	V
Output low voltage ( $I_{LOAD} = 0.8\text{mA}$ ) All ports ( $I_{LOAD} = 10.0$ mA) PTB0–PTB5, PTC0–PTC7, PTE0–PTE7, PTF0–PTF7	$V_{OL}$	—	—	0.4	V
Input high voltage All ports, $\overline{\text{RST}}$ , $\overline{\text{IRQ}}$ , OSC1	$V_{IH}$	$0.7 \times V_{DD}$	—	$V_{DD}$	V
Input low voltage All ports, $\overline{\text{RST}}$ , $\overline{\text{IRQ}}$ , OSC1	$V_{IL}$	$V_{SS}$	—	$0.3 \times V_{DD}$	V
$V_{DD}$ supply current					
Run <sup>(3)</sup> , $f_{OP} = 4$ MHz with all modules on	$I_{DD}$	—	5.5	8	mA
with ADC on		—	4.5	6	mA
with ADC off		—	3	5	mA
Wait <sup>(4)</sup> , $f_{OP} = 4$ MHz (all modules off)		—	1.5	2.5	mA
Stop, $f_{OP} = 8$ kHz <sup>(5)</sup> with OSC, RTC, LCD <sup>(6)</sup> , LVI on		—	180	250	$\mu\text{A}$
with OSC, RTC, LCD <sup>(6)</sup> on		—	15	20	$\mu\text{A}$
with OSC, RTC on all modules off		—	2.5	4	$\mu\text{A}$
Digital I/O ports Hi-Z leakage current All ports, $\overline{\text{RST}}$	$I_{IL}$	—	—	$\pm 10$	$\mu\text{A}$
Input current $\overline{\text{IRQ}}$	$I_{IN}$	—	—	$\pm 1$	$\mu\text{A}$

Table 24-5. 3.3V DC Electrical Characteristics

Characteristic <sup>(1)</sup>	Symbol	Min	Typ <sup>(2)</sup>	Max	Unit
Capacitance Ports (as input or output)	C <sub>OUT</sub> C <sub>IN</sub>	— —	— —	12 8	pF
POR re-arm voltage <sup>(7)</sup>	V <sub>POR</sub>	0	—	100	mV
POR rise-time ramp rate <sup>(8)</sup>	R <sub>POR</sub>	0.02	—	—	V/ms
Monitor mode entry voltage (at $\overline{\text{IRQ}}$ pin)	V <sub>HI</sub>	1.5 × V <sub>DD</sub>	—	8	V
Pullup resistors <sup>(9)</sup> PTA0–PTA3 and PTD4–PTD7 as KBI0–KBI7 $\overline{\text{RST}}$ , $\overline{\text{IRQ}}$	R <sub>PU1</sub> R <sub>PU2</sub>	21 21	30 30	39 39	kΩ kΩ
Low-voltage inhibit, trip falling voltage	V <sub>TRIPF</sub>	2.1	—	2.8	V
Low-voltage inhibit, trip rising voltage	V <sub>TRIPR</sub>	2.2	—	2.9	V

Notes:

- V<sub>DD</sub> = 3.0 to 3.6 Vdc, V<sub>SS</sub> = 0 Vdc, T<sub>A</sub> = T<sub>L</sub> to T<sub>H</sub>, unless otherwise noted.
- Typical values reflect average measurements at midpoint of voltage range, 25 °C only.
- Run (operating) I<sub>DD</sub> measured using external square wave clock source. All inputs 0.2 V from rail. No dc loads. Less than 100 pF on all outputs. C<sub>L</sub> = 20 pF on OSC2. All ports configured as inputs. OSC2 capacitance linearly affects run I<sub>DD</sub>.
- Wait I<sub>DD</sub> measured using external square wave clock source. All inputs 0.2 V from rail. No dc loads. Less than 100 pF on all outputs. C<sub>L</sub> = 20 pF on OSC2. All ports configured as inputs. OSC2 capacitance linearly affects wait I<sub>DD</sub>.
- The 8kHz clock is from a 32kHz external square wave clock input at OSC1, for the driving the RTC. Due to loading effects, the I<sub>DD</sub> values will be larger when a 32kHz crystal circuit is connected.
- LCD driver configured for low current mode.
- Maximum is highest voltage that POR is guaranteed.
- If minimum V<sub>DD</sub> is not reached before the internal POR reset is released,  $\overline{\text{RST}}$  must be driven low externally until minimum V<sub>DD</sub> is reached.
- R<sub>PU1</sub> and R<sub>PU2</sub> are measured at V<sub>DD</sub> = 3.3V.

24.8 5V Control Timing

Table 24-6. 5V Control Timing

Characteristic <sup>(1)</sup>	Symbol	Min	Max	Unit
Internal operating frequency <sup>(2)</sup>	f <sub>OP</sub>	—	8	MHz
$\overline{\text{RST}}$ input pulse width low <sup>(3)</sup>	t <sub>IRL</sub>	750	—	ns

Notes:

- V<sub>SS</sub> = 0 Vdc; timing shown with respect to 20% V<sub>DD</sub> and 70% V<sub>DD</sub>, unless otherwise noted.
- Some modules may require a minimum frequency greater than dc for proper operation; see appropriate table for this information.
- Minimum pulse width reset is guaranteed to be recognized. It is possible for a smaller pulse width to cause a reset.



## 24.9 3.3V Control Timing

Table 24-7. 3.3V Control Timing

Characteristic <sup>(1)</sup>	Symbol	Min	Max	Unit
Internal operating frequency <sup>(2)</sup>	f <sub>OP</sub>	—	4	MHz
RST input pulse width low <sup>(3)</sup>	t <sub>IRL</sub>	1.5	—	μs

**Notes:**

1. V<sub>SS</sub> = 0 Vdc; timing shown with respect to 20% V<sub>DD</sub> and 70% V<sub>DD</sub>, unless otherwise noted.
2. Some modules may require a minimum frequency greater than dc for proper operation; see appropriate table for this information.
3. Minimum pulse width reset is guaranteed to be recognized. It is possible for a smaller pulse width to cause a reset.

## 24.10 5V Oscillator Characteristics

Table 24-8. 5V Oscillator Specifications

Characteristic	Symbol	Min	Typ	Max	Unit
Internal oscillator clock frequency	f <sub>ICLK</sub>		50k <sup>(1)</sup>		Hz
External reference clock to OSC1 <sup>(2)</sup>	f <sub>OSC</sub>	dc	—	20M	Hz
Crystal reference frequency <sup>(3)</sup>	f <sub>XCLK</sub>	—	32.768k	4.9152M	Hz
Crystal load capacitance <sup>(4)</sup>	C <sub>L</sub>	—	—	—	
Crystal fixed capacitance	C <sub>1</sub>	—	2 × C <sub>L</sub> (27p)	—	F
Crystal tuning capacitance	C <sub>2</sub>	—	2 × C <sub>L</sub> (33p)	—	F
Feedback bias resistor	R <sub>B</sub>	—	20M	—	Ω
Series resistor <sup>(5)</sup>	R <sub>S</sub>	—	100k	—	Ω

**Notes:**

1. Typical value reflect average measurements at midpoint of voltage range, 25 °C only. See [Figure 24-1](#) for plot.
2. No more than 10% duty cycle deviation from 50%.
3. Fundamental mode crystals only.
4. Consult crystal manufacturer's data.
5. Not Required for high frequency crystals.

24.11 3.3V Oscillator Characteristics

Table 24-9. 3.3V Oscillator Specifications

Characteristic	Symbol	Min	Typ	Max	Unit
Internal oscillator clock frequency	$f_{iCLK}$		47k <sup>(1)</sup>		Hz
External reference clock to OSC1 <sup>(2)</sup>	$f_{OSC}$	dc	—	16M	Hz
Crystal reference frequency <sup>(3)</sup>	$f_{XCLK}$	—	32.768k	4.9152M	Hz
Crystal load capacitance <sup>(4)</sup>	$C_L$	—	—	—	
Crystal fixed capacitance	$C_1$	—	$2 \times C_L$ (27p)	—	F
Crystal tuning capacitance	$C_2$	—	$2 \times C_L$ (33p)	—	F
Feedback bias resistor	$R_B$	—	20M	—	$\Omega$
Series resistor <sup>(5)</sup>	$R_S$	—	100k	—	$\Omega$

Notes:

1. Typical value reflect average measurements at midpoint of voltage range, 25 xC only. See Figure 24-1 for plot.
2. No more than 10% duty cycle deviation from 50%.
3. Fundamental mode crystals only.
4. Consult crystal manufacturer's data.
5. Not Required for high frequency crystals.

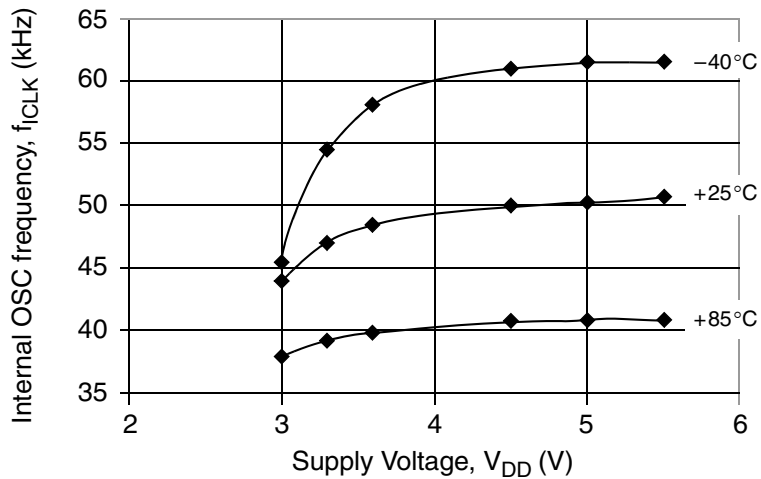


Figure 24-1. Typical Internal Oscillator Frequency

24.12 5V ADC Electrical Characteristics

Table 24-10. 5V ADC Electrical Characteristics

Characteristic	Symbol	Min	Max	Unit	Notes
Supply voltage	$V_{DDA}$	4.5	5.5	V	$V_{DDA}$ is an dedicated pin and should be tied to $V_{DD}$ on the PCB with proper decoupling.
Input range	$V_{ADIN}$	0	$V_{DDA}$	V	$V_{ADIN} \leq V_{DDA}$
Resolution	$B_{AD}$	10	10	bits	
Absolute accuracy	$A_{AD}$	—	$\pm 1.5$	LSB	Includes quantization. $\pm 0.5 \text{ LSB} = \pm 1 \text{ ADC count.}$
ADC internal clock	$f_{ADIC}$	32 k	2 M	Hz	$t_{ADIC} = 1/f_{ADIC}$
Conversion range	$R_{AD}$	$V_{REFL}$	$V_{REFH}$	V	
ADC voltage reference high	$V_{REFH}$	—	$V_{DDA} + 0.1$	V	
ADC voltage reference low	$V_{REFL}$	$V_{SSA} - 0.1$	—	V	$V_{SSA}$ is tied to $V_{SS}$ internally.
Conversion time	$t_{ADC}$	16	17	$t_{ADIC}$ cycles	
Sample time	$t_{ADS}$	5	—	$t_{ADIC}$ cycles	
Monotonically	$M_{AD}$	Guaranteed			
Zero input reading	$Z_{ADI}$	000	001	HEX	$V_{ADIN} = V_{REFL}$
Full-scale reading	$F_{ADI}$	3FC	3FF	HEX	$V_{ADIN} = V_{REFH}$
Input capacitance	$C_{ADI}$	—	20	pF	Not tested.
Input impedance	$R_{ADI}$	20M	—	$\Omega$	
$V_{REFH}/V_{REFL}$	$I_{VREF}$	—	1.6	mA	Not tested.

24.13 3.3V ADC Electrical Characteristics

Table 24-11. 3.3V ADC Electrical Characteristics

Characteristic	Symbol	Min	Max	Unit	Notes
Supply voltage	$V_{DDA}$	3.0	3.6	V	$V_{DDA}$ is an dedicated pin and should be tied to $V_{DD}$ on the PCB with proper decoupling.
Input range	$V_{ADIN}$	0	$V_{DDA}$	V	$V_{ADIN} \leq V_{DDA}$
Resolution	$B_{AD}$	10	10	bits	
Absolute accuracy	$A_{AD}$	—	$\pm 1.5$	LSB	Includes quantization. $\pm 0.5 \text{ LSB} = \pm 1 \text{ ADC count.}$
ADC internal clock	$f_{ADIC}$	32 k	2 M	Hz	$t_{ADIC} = 1/f_{ADIC}$
Conversion range	$R_{AD}$	$V_{REFL}$	$V_{REFH}$	V	
ADC voltage reference high	$V_{REFH}$	—	$V_{DDA} + 0.1$	V	
ADC voltage reference low	$V_{REFL}$	$V_{SSA} - 0.1$	—	V	$V_{SSA}$ is tied to $V_{SS}$ internally.
Conversion time	$t_{ADC}$	16	17	$t_{ADIC}$ cycles	
Sample time	$t_{ADS}$	5	—	$t_{ADIC}$ cycles	
Monotonically	$M_{AD}$	Guaranteed			
Zero input reading	$Z_{ADI}$	000	001	HEX	$V_{ADIN} = V_{REFL}$
Full-scale reading	$F_{ADI}$	3FC	3FF	HEX	$V_{ADIN} = V_{REFH}$
Input capacitance	$C_{ADI}$	—	20	pF	Not tested.
Input impedance	$R_{ADI}$	20M	—	$\Omega$	Measured at 5V
$V_{REFH}/V_{REFL}$	$I_{VREF}$	—	1.6	mA	Not tested.

## 24.14 Timer Interface Module Characteristics

**Table 24-12. Timer Interface Module Characteristics**

Characteristic	Symbol	Min	Max	Unit
Input capture pulse width	$t_{TIH}, t_{TIL}$	1	—	$t_{CYC}$

## 24.15 CGM Electrical Specifications

**Table 24-13. CGM Electrical Specifications**

Characteristic	Symbol	Min	Typ	Max	Unit
Reference frequency	$f_{RDV}$	30	32.768	100	kHz
Range nominal multiplies	$f_{NOM}$	—	38.4	—	kHz
VCO center-of-range frequency	$f_{VRS}$	38.4k	—	40.0M	Hz
VCO range linear range multiplier	L	1	—	255	
VCO power-of-two-range multiplier	$2^E$	1	—	4	
VCO multiply factor	N	1	—	4095	
VCO prescale multiplier	$2^P$	1	—	8	
Reference divider factor	R	1	1	15	
VCO operating frequency	$f_{VCLK}$	38.4k	—	40.0M	Hz
Manual acquisition time	$t_{LOCK}$	—	—	50	ms
Automatic lock time	$t_{LOCK}$	—	—	50	ms
PLL jitter <sup>(1)</sup>	$f_J$	0	—	$f_{RCLK} \times 0.025\% \times 2^P N/4$	Hz

**Notes:**

1. Deviation of average bus frequency over 2ms. N = VCO multiplier.

24.16 5V SPI Characteristics

Table 24-14. 5V SPI Characteristics

Diagram Number <sup>(1)</sup>	Characteristic <sup>(2)</sup>	Symbol	Min	Max	Unit
	Operating frequency Master Slave	$f_{OP(M)}$ $f_{OP(S)}$	$f_{OP}/128$ dc	$f_{OP}/2$ $f_{OP}$	MHz MHz
1	Cycle time Master Slave	$t_{CYC(M)}$ $t_{CYC(S)}$	2 1	128 —	$t_{CYC}$ $t_{CYC}$
2	Enable lead time	$t_{Lead(S)}$	1	—	$t_{CYC}$
3	Enable lag time	$t_{Lag(S)}$	1	—	$t_{CYC}$
4	Clock (SPSCK) high time Master Slave	$t_{SCKH(M)}$ $t_{SCKH(S)}$	$t_{CYC} -25$ $1/2 t_{CYC} -25$	$64 t_{CYC}$ —	ns ns
5	Clock (SPSCK) low time Master Slave	$t_{SCKL(M)}$ $t_{SCKL(S)}$	$t_{CYC} -25$ $1/2 t_{CYC} -25$	$64 t_{CYC}$ —	ns ns
6	Data setup time (inputs) Master Slave	$t_{SU(M)}$ $t_{SU(S)}$	30 30	— —	ns ns
7	Data hold time (inputs) Master Slave	$t_{H(M)}$ $t_{H(S)}$	30 30	— —	ns ns
8	Access time, slave <sup>(3)</sup> CPHA = 0 CPHA = 1	$t_{A(CP0)}$ $t_{A(CP1)}$	0 0	40 40	ns ns
9	Disable time, slave <sup>(4)</sup>	$t_{DIS(S)}$	—	40	ns
10	Data valid time, after enable edge Master Slave <sup>(5)</sup>	$t_{V(M)}$ $t_{V(S)}$	— —	50 50	ns ns
11	Data hold time, outputs, after enable edge Master Slave	$t_{HO(M)}$ $t_{HO(S)}$	0 0	— —	ns ns

Notes:

1. Numbers refer to dimensions in [Figure 24-2](#) and [Figure 24-3](#).
2. All timing is shown with respect to 20%  $V_{DD}$  and 70%  $V_{DD}$ , unless noted; 100 pF load on all SPI pins.
3. Time to data active from high-impedance state
4. Hold time to high-impedance state
5. With 100 pF on all SPI pins

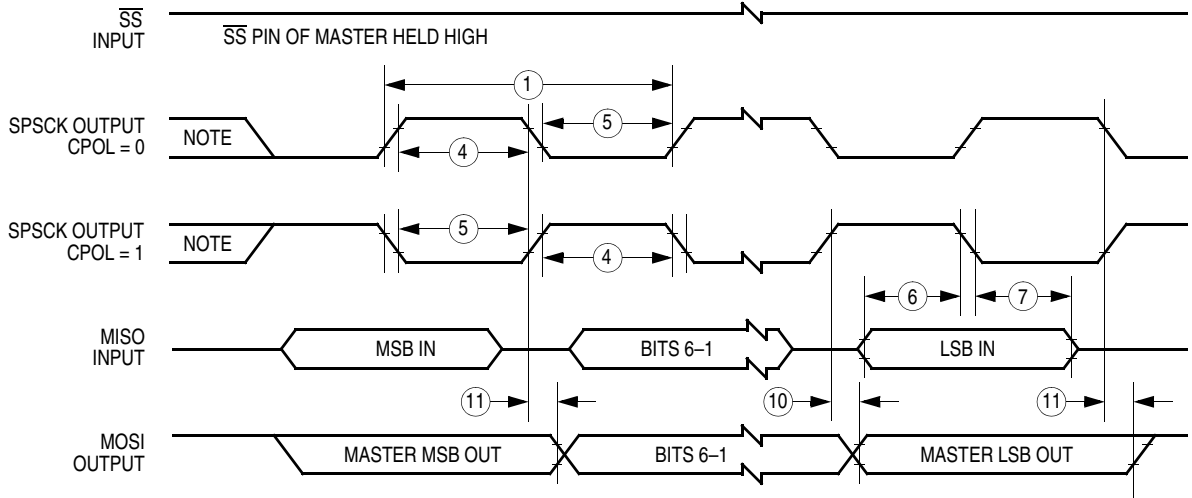
24.17 3.3V SPI Characteristics

Table 24-15. 3.3V SPI Characteristics

Diagram Number <sup>(1)</sup>	Characteristic <sup>(2)</sup>	Symbol	Min	Max	Unit
	Operating frequency Master Slave	$f_{OP(M)}$ $f_{OP(S)}$	$f_{OP}/128$ dc	$f_{OP}/2$ $f_{OP}$	MHz MHz
1	Cycle time Master Slave	$t_{CYC(M)}$ $t_{CYC(S)}$	2 1	128 —	$t_{CYC}$ $t_{CYC}$
2	Enable lead time	$t_{Lead(s)}$	1	—	$t_{CYC}$
3	Enable lag time	$t_{Lag(s)}$	1	—	$t_{CYC}$
4	Clock (SPSCK) high time Master Slave	$t_{SCKH(M)}$ $t_{SCKH(S)}$	$t_{CYC} - 35$ $1/2 t_{CYC} - 35$	$64 t_{CYC}$ —	ns ns
5	Clock (SPSCK) low time Master Slave	$t_{SCKL(M)}$ $t_{SCKL(S)}$	$t_{CYC} - 35$ $1/2 t_{CYC} - 35$	$64 t_{CYC}$ —	ns ns
6	Data setup time (inputs) Master Slave	$t_{SU(M)}$ $t_{SU(S)}$	40 40	— —	ns ns
7	Data hold time (inputs) Master Slave	$t_{H(M)}$ $t_{H(S)}$	40 40	— —	ns ns
8	Access time, slave <sup>(3)</sup> CPHA = 0 CPHA = 1	$t_{A(CP0)}$ $t_{A(CP1)}$	0 0	50 50	ns ns
9	Disable time, slave <sup>(4)</sup>	$t_{DIS(S)}$	—	50	ns
10	Data valid time, after enable edge Master Slave <sup>(5)</sup>	$t_{V(M)}$ $t_{V(S)}$	— —	60 60	ns ns
11	Data hold time, outputs, after enable edge Master Slave	$t_{HO(M)}$ $t_{HO(S)}$	0 0	— —	ns ns

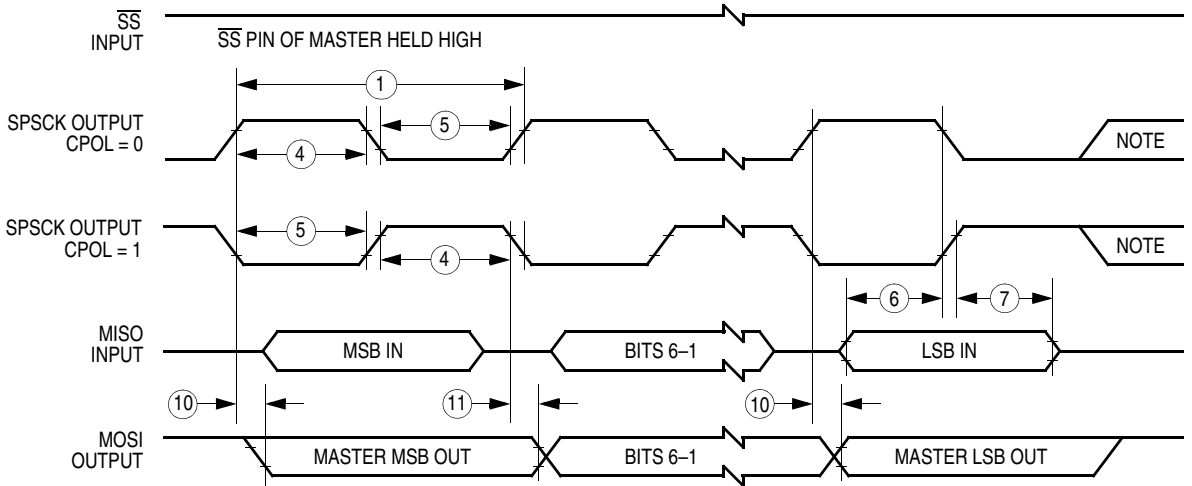
Notes:

- Numbers refer to dimensions in [Figure 24-2](#) and [Figure 24-3](#).
- All timing is shown with respect to 20%  $V_{DD}$  and 70%  $V_{DD}$ , unless noted; 100 pF load on all SPI pins.
- Time to data active from high-impedance state
- Hold time to high-impedance state
- With 100 pF on all SPI pins



Note: This first clock edge is generated internally, but is not seen at the SPSCK pin.

a) SPI Master Timing (CPHA = 0)

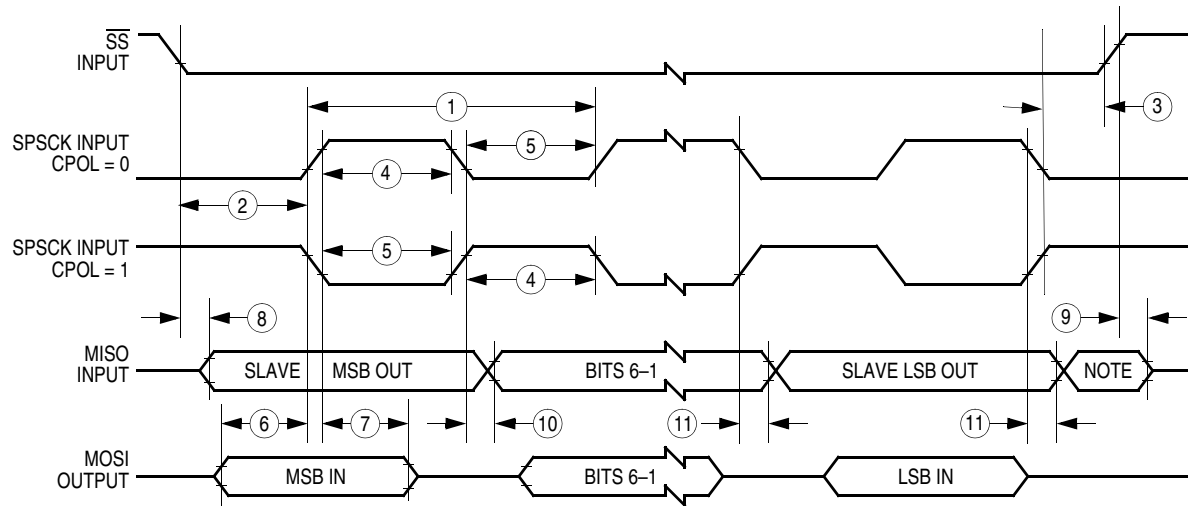


Note: This last clock edge is generated internally, but is not seen at the SPSCK pin.

b) SPI Master Timing (CPHA = 1)

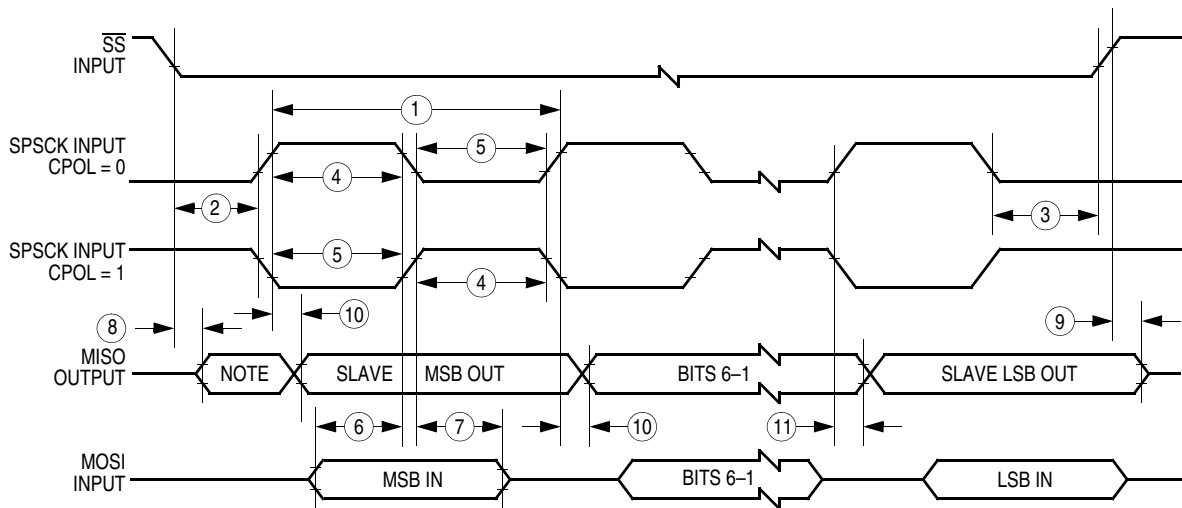
Figure 24-2. SPI Master Timing





Note: Not defined but normally MSB of character just received

a) SPI Slave Timing (CPHA = 0)



Note: Not defined but normally LSB of character previously transmitted

b) SPI Slave Timing (CPHA = 1)

Figure 24-3. SPI Slave Timing

24.18 FLASH Memory Characteristics

Table 24-16. FLASH Memory Electrical Characteristics

Characteristic	Symbol	Min.	Max.	Unit
RAM data retention voltage	$V_{RDR}$	1.3	—	V
Number of rows per page		2		Rows
Number of bytes per page		128		Bytes
Read bus clock frequency	$f_{read}^{(1)}$	32k	8M	Hz
Page erase time	$t_{erase}^{(2)}$	1	—	ms
Mass erase time	$t_{merase}^{(3)}$	4	—	ms
PGM/ERASE to HVEN setup time	$t_{nvs}$	10	—	$\mu$ s
High-voltage hold time	$t_{nvh}$	5	—	$\mu$ s
High-voltage hold time (mass erase)	$t_{nvhl}$	100	—	$\mu$ s
Program hold time	$t_{pgs}$	5	—	$\mu$ s
Program time	$t_{prog}$	30	40	$\mu$ s
Address/data setup time	$t_{ads}$	—	30	ns
Address/data hold time	$t_{adh}$	—	30	ns
Recovery time	$t_{rcv}^{(4)}$	1	—	$\mu$ s
Cumulative HV period	$t_{hv}^{(5)}$	—	25	ms
Row erase endurance <sup>(6)</sup>	—	10k	—	Cycles
Row program endurance <sup>(7)</sup>	—	10k	—	Cycles
Data retention time <sup>(8)</sup>	—	10	—	Years

Notes:

- $f_{read}$  is defined as the frequency range for which the FLASH memory can be read.
- If the page erase time is longer than  $t_{erase}$  (Min.), there is no erase-disturb, but it reduces the endurance of the FLASH memory.
- If the mass erase time is longer than  $t_{merase}$  (Min.), there is no erase-disturb, but it reduces the endurance of the FLASH memory.
- It is defined as the time it needs before the FLASH can be read after turning off the high voltage charge pump, by clearing HVEN to logic 0.
- $t_{hv}$  is the cumulative high voltage programming time to the same row before next erase, and the same address can not be programmed twice before next erase.
- The minimum row endurance value specifies each row of the FLASH memory is guaranteed to work for at least this many erase/program cycles.
- The minimum row endurance value specifies each row of the FLASH memory is guaranteed to work for at least this many erase/program cycle.
- The FLASH is guaranteed to retain data over the entire operating temperature range for at least the minimum time specified.

## Section 25. Mechanical Specifications

### 25.1 Contents

25.2	Introduction . . . . .	451
25.3	64-Pin Low-Profile Quad Flat Pack (LQFP) . . . . .	452
25.4	64-Pin Quad Flat Pack (QFP) . . . . .	453
25.5	80-Pin Low-Profile Quad Flat Pack (LQFP) . . . . .	454
25.6	80-Pin Quad Flat Pack (QFP) . . . . .	455

### 25.2 Introduction

This section gives the dimensions for:

- 64-pin low-profile quad flat pack (case no. 840F)
- 64-pin quad flat pack (case no. 840B)
- 80-pin low-profile quad flat pack (case no. 917)
- 80-pin quad flat pack (case no. 841B)

Mechanical Specifications

25.3 64-Pin Low-Profile Quad Flat Pack (LQFP)

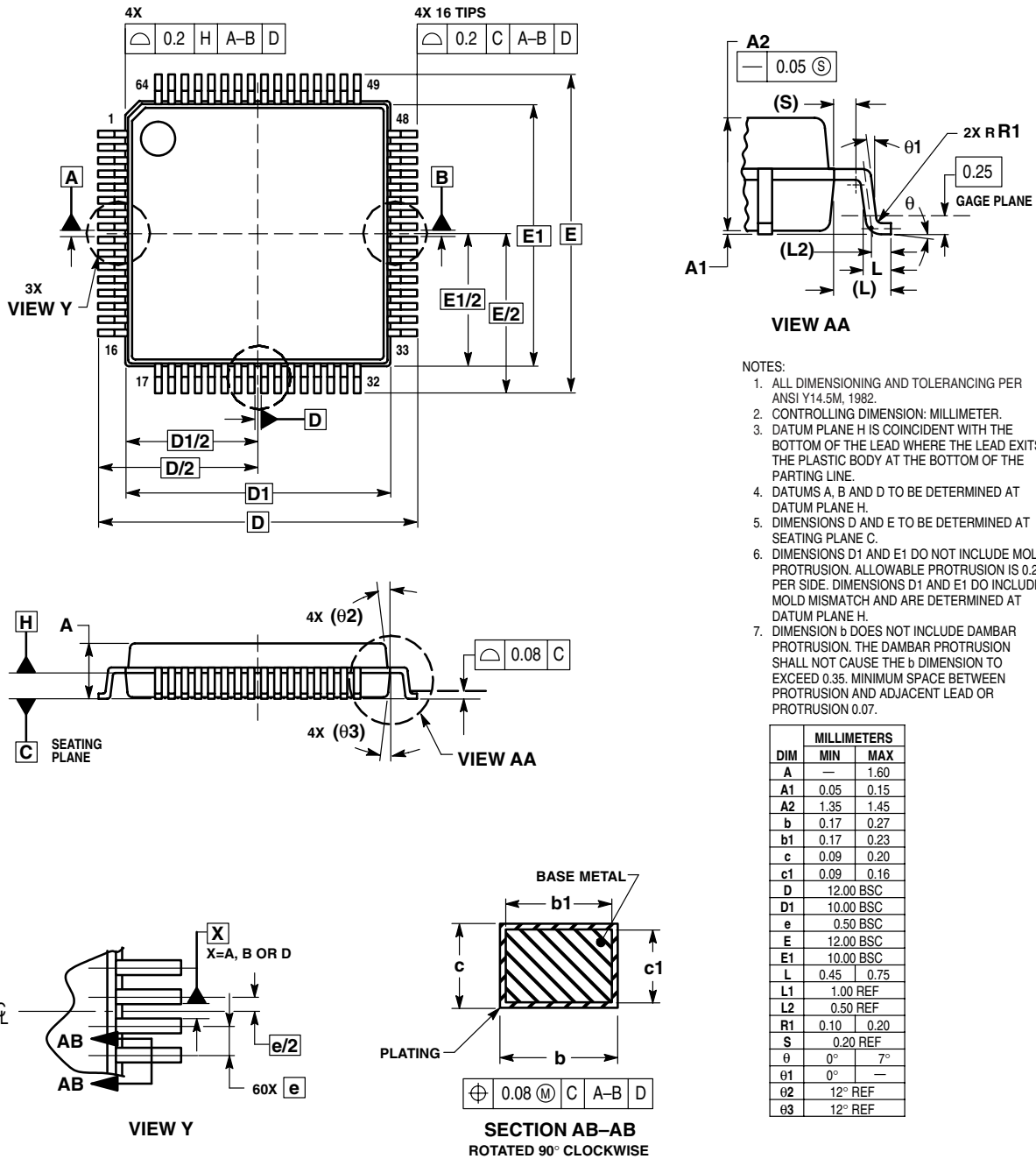


Figure 25-1. 64-Pin Low-Profile Quad Flat Pack (Case No. 840F)

25.4 64-Pin Quad Flat Pack (QFP)

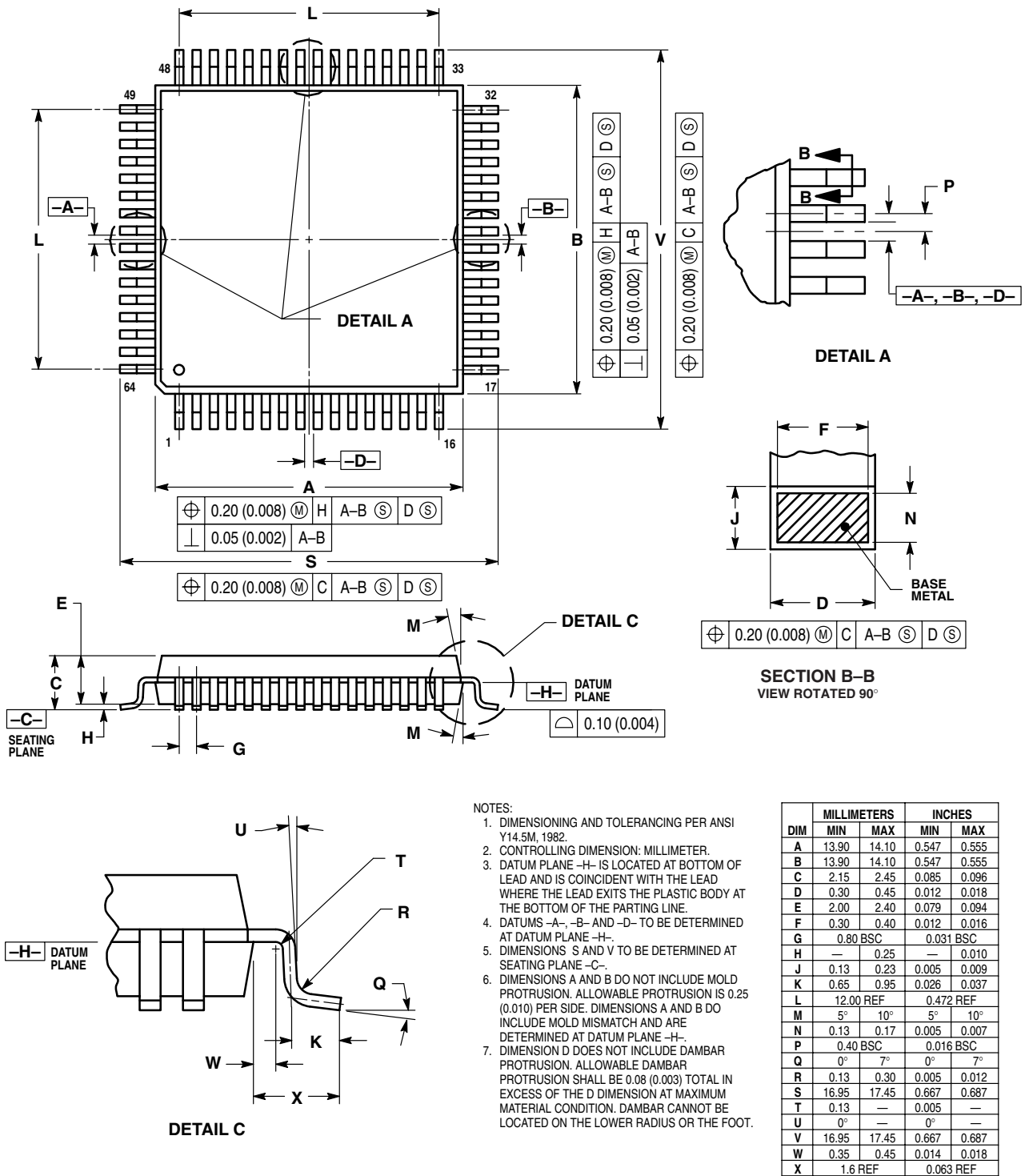


Figure 25-2. 64-Pin Quad Flat Pack (Case No. 840B)

Mechanical Specifications

25.5 80-Pin Low-Profile Quad Flat Pack (LQFP)

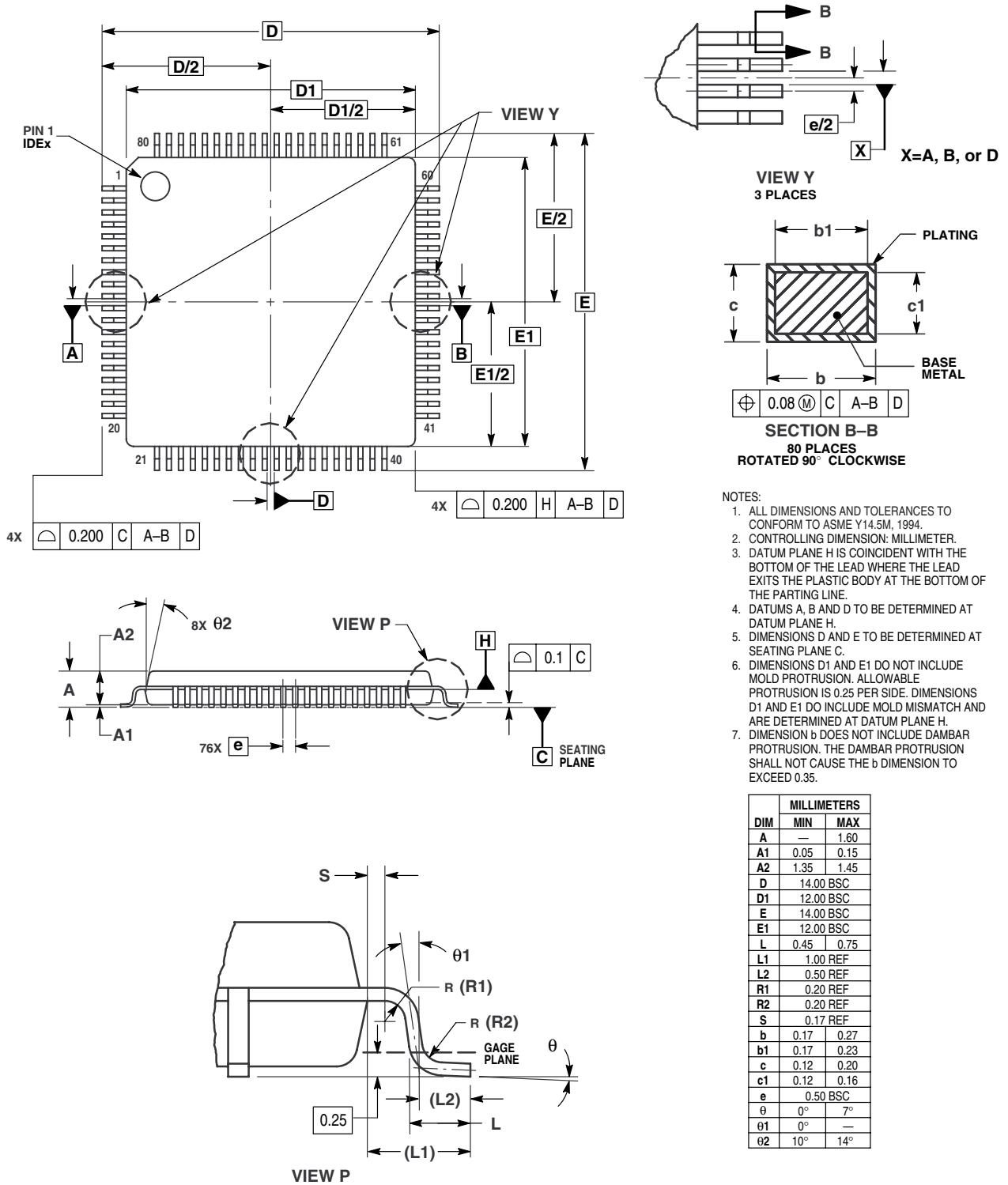
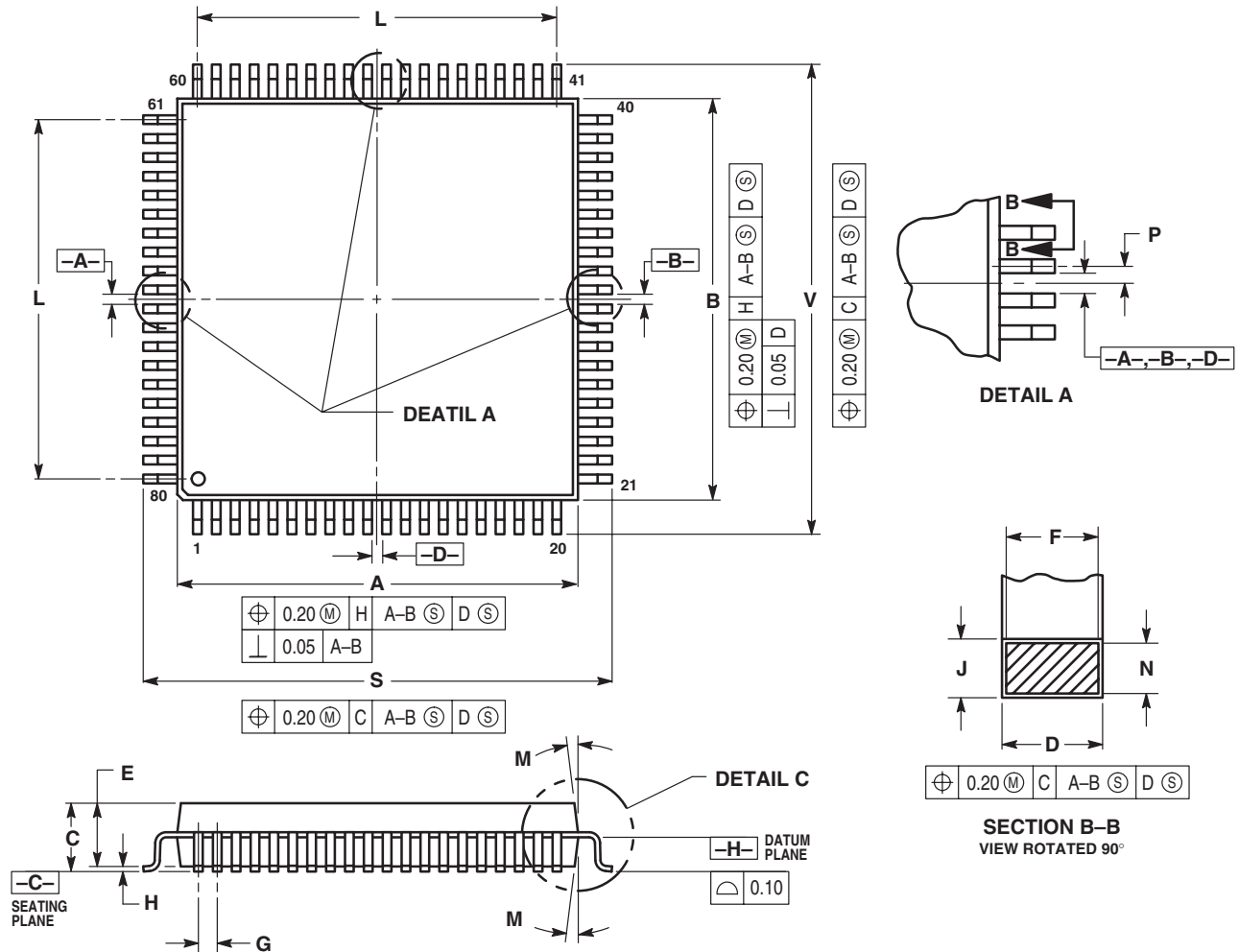


Figure 25-3. 80-Pin Low-Profile Quad Flat Pack (Case No. 917)

25.6 80-Pin Quad Flat Pack (QFP)



NOTES:

1. DIMENSIONING AND TOLERANCING PER ANSI Y14.5M, 1982.
2. CONTROLLING DIMENSION: MILLIMETER.
3. DATUM PLANE -H- IS LOCATED AT BOTTOM OF LEAD AND IS COINCIDENT WITH THE LEAD WHERE THE LEAD EXITS THE PLASTIC BODY AT THE BOTTOM OF THE PARTING LINE.
4. DATUMS -A-, -B- AND -D- TO BE DETERMINED AT DATUM PLANE -H-.
5. DIMENSIONS S AND V TO BE DETERMINED AT SEATING PLANE -C-.
6. DIMENSIONS A AND B DO NOT INCLUDE MOLD PROTRUSION. ALLOWABLE PROTRUSION IS 0.25 PER SIDE. DIMENSIONS A AND B DO INCLUDE MOLD MISMATCH AND ARE DETERMINED AT DATUM PLANE -H-.
7. DIMENSION D DOES NOT INCLUDE DAMBAR PROTRUSION. ALLOWABLE DAMBAR PROTRUSION SHALL BE 0.08 TOTAL IN EXCESS OF THE D DIMENSION AT MAXIMUM MATERIAL CONDITION. DAMBAR CANNOT BE LOCATED ON THE LOWER RADIUS OR THE FOOT.

DIM	MILLIMETERS	
	MIN	MAX
A	13.90	14.10
B	13.90	14.10
C	2.15	2.45
D	0.22	0.38
E	2.00	2.40
F	0.22	0.33
G	0.65 BSC	
H	—	0.25
J	0.13	0.23
K	0.65	0.95
L	12.35 REF	
M	5°	10°
N	0.13	0.17
P	0.325 BSC	
Q	0°	7°
R	0.13	0.30
S	16.95	17.45
T	0.13	—
U	0°	—
V	16.95	17.45
W	0.35	0.45
X	1.6 REF	

Figure 25-4. 80-Pin Quad Flat Pack (Case No. 841B)





## Section 26. Ordering Information

### 26.1 Contents

26.2	Introduction .....	457
26.3	MC Order Numbers .....	457

### 26.2 Introduction

This section contains ordering numbers for the MC68HC908LJ24.

### 26.3 MC Order Numbers

**Table 26-1. MC Order Numbers**

MC Order Number	Package	Operating Temperature Range
MC68HC908LJ24CPB	64-pin LQFP	-40 to +85 °C
MC68HC908LJ24CFU	64-pin QFP	-40 to +85 °C
MC68HC908LJ24CPK	80-pin LQFP	-40 to +85 °C
MC68HC908LJ24CFQ	80-pin QFP	-40 to +85 °C



## Appendix A. MC68HC908LK24

### A.1 Contents

A.2	Introduction . . . . .	459
A.3	Oscillator . . . . .	460
A.4	Low-Voltage Inhibit . . . . .	460
A.5	Electrical Specifications . . . . .	461
A.5.1	5V DC Electrical Characteristics . . . . .	461
A.5.2	3.3V DC Electrical Characteristics . . . . .	461
A.5.3	5V Oscillator Characteristics . . . . .	462
A.5.4	3.3V Oscillator Characteristics . . . . .	462
A.6	MC Order Numbers . . . . .	462

### A.2 Introduction

The MC68HC908LK24 is a MC68HC908LJ24 with a low-power oscillator that supports a 32.768 kHz crystal only.

The entire data book apply to the MC68HC908LK24 device, with exceptions outlined in this appendix.

### A.3 Oscillator

The low-power oscillator supports a reference frequency of 32.768kHz only; either from a crystal oscillator circuit (Figure A-1) or a direct clock input to the OSC1 pin.

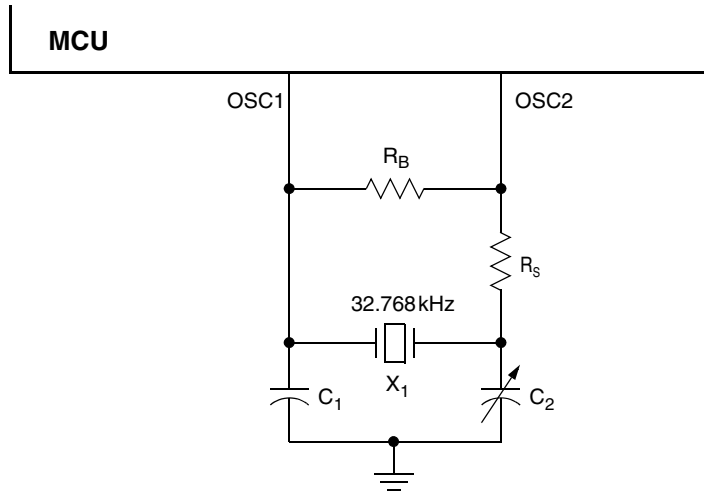


Figure A-1. MC68HC908LK24 Crystal Oscillator Connection

### A.4 Low-Voltage Inhibit

The LVIPWRD bit in CONFIG1 register is logic 1 after any reset.

Address: \$001F

	Bit 7	6	5	4	3	2	1	Bit 0
Read:	COPRS	LVISTOP	LVIRSTD	LVIPWRD	0	SSREC	STOP	COPD
Write:								
MC68HC908LK24	Reset:	0	0	0	1	0	0	0
MC68HC908LJ24	Reset:	0	0	0	0 <sup>††</sup>	0	0	0

†† Reset by POR only.  = Unimplemented

Figure A-2. MC68HC908LK24 Configuration Register 1 (CONFIG1)

LVIPWRD — LVI Power Disable Bit

LVIPWRD disables the LVI module.

- 1 = LVI module power disabled
- 0 = LVI module power enabled

## A.5 Electrical Specifications

Electrical specifications for the MC68HC908LJ24 apply to the MC68HC908LK24, except for the parameters indicated below.

### A.5.1 5V DC Electrical Characteristics

Table A-1. 5V DC Electrical Characteristics

Characteristic <sup>(1)</sup>	Symbol	Min	Typ <sup>(2)</sup>	Max	Unit
V <sub>DD</sub> supply current Stop, f <sub>OP</sub> = 8 kHz <sup>(3)</sup> with OSC, RTC on	I <sub>DD</sub>	—	5.5	7.5	μA
Low-voltage inhibit, trip rising voltage LVI reset disabled (LVIRSTD = 1) LVI reset enabled (LVIRSTD = 0)	V <sub>TRIPR</sub>	3.7 3.62	— —	4.7 4.62	V V

**Notes:**

- V<sub>DD</sub> = 4.5 to 5.5 Vdc, V<sub>SS</sub> = 0 Vdc, T<sub>A</sub> = T<sub>L</sub> to T<sub>H</sub>, unless otherwise noted.
- Typical values reflect average measurements at midpoint of voltage range, 25 °C only.
- The 8kHz clock is from a 32kHz external square wave clock input at OSC1, for the driving the RTC. Due to loading effects, the I<sub>DD</sub> values will be larger when a 32kHz crystal circuit is connected.

### A.5.2 3.3V DC Electrical Characteristics

Table A-2. 3.3V DC Electrical Characteristics

Characteristic <sup>(1)</sup>	Symbol	Min	Typ <sup>(2)</sup>	Max	Unit
Low-voltage inhibit, trip rising voltage LVI disabled (LVIRSTD = 1) LVI enabled (LVIRSTD = 0)	V <sub>TRIPR</sub>	2.2 2.12	— —	2.9 2.82	V V

**Notes:**

- V<sub>DD</sub> = 3.0 to 3.6 Vdc, V<sub>SS</sub> = 0 Vdc, T<sub>A</sub> = T<sub>L</sub> to T<sub>H</sub>, unless otherwise noted.
- Typical values reflect average measurements at midpoint of voltage range, 25 °C only.

## A.5.3 5V Oscillator Characteristics

Table A-3. 5V Oscillator Specifications

Characteristic	Symbol	Min	Typ	Max	Unit
External reference clock to OSC1 <sup>(1)</sup>	f <sub>OSC</sub>	dc	32.768k	—	Hz
Crystal reference frequency <sup>(2)</sup>	f <sub>XCLK</sub>	—	32.768k	—	Hz

**Notes:**

1. No more than 10% duty cycle deviation from 50%.
2. Fundamental mode crystals only.

## A.5.4 3.3V Oscillator Characteristics

Table A-4. 3.3V Oscillator Specifications

Characteristic	Symbol	Min	Typ	Max	Unit
External reference clock to OSC1 <sup>(1)</sup>	f <sub>OSC</sub>	dc	32.768k	—	Hz
Crystal reference frequency <sup>(2)</sup>	f <sub>XCLK</sub>	—	32.768k	—	Hz

**Notes:**

1. No more than 10% duty cycle deviation from 50%.
2. Fundamental mode crystals only.

## A.6 MC Order Numbers

**Table A-5** shows the ordering numbers for the MC68HC908LK24.

Table A-5. MC68HC908LK24 Order Numbers

MC Order Number	Package	Operating Temperature Range
MC68HC908LK24CPB	64-pin LQFP	–40 to +85 °C
MC68HC908LK24CFU	64-pin QFP	–40 to +85 °C
MC68HC908LK24CPK	80-pin LQFP	–40 to +85 °C
MC68HC908LK24CFQ	80-pin QFP	–40 to +85 °C

**Freescale Semiconductor, Inc.**

**Freescale Semiconductor, Inc.**

**For More Information On This Product,  
Go to: [www.freescale.com](http://www.freescale.com)**

## **HOW TO REACH US:**

### **USA/EUROPE/LOCATIONS NOT LISTED:**

Motorola Literature Distribution  
P.O. Box 5405  
Denver, Colorado 80217  
1-800-521-6274 or 480-768-2130

### **JAPAN:**

Motorola Japan Ltd.  
SPS, Technical Information Center  
3-20-1, Minami-Azabu, Minato-ku  
Tokyo 106-8573, Japan  
81-3-3440-3569

### **ASIA/PACIFIC:**

Motorola Semiconductors H.K. Ltd.  
Silicon Harbour Centre  
2 Dai King Street  
Tai Po Industrial Estate  
Tai Po, N.T., Hong Kong  
852-26668334

### **HOME PAGE:**

<http://motorola.com/semiconductors>



Information in this document is provided solely to enable system and software implementers to use Motorola products. There are no express or implied copyright licenses granted hereunder to design or fabricate any integrated circuits or integrated circuits based on the information in this document.

Motorola reserves the right to make changes without further notice to any products herein. Motorola makes no warranty, representation or guarantee regarding the suitability of its products for any particular purpose, nor does Motorola assume any liability arising out of the application or use of any product or circuit, and specifically disclaims any and all liability, including without limitation consequential or incidental damages. "Typical" parameters that may be provided in Motorola data sheets and/or specifications can and do vary in different applications and actual performance may vary over time. All operating parameters, including "Typicals", must be validated for each customer application by customer's technical experts. Motorola does not convey any license under its patent rights nor the rights of others. Motorola products are not designed, intended, or authorized for use as components in systems intended for surgical implant into the body, or other applications intended to support or sustain life, or for any other application in which the failure of the Motorola product could create a situation where personal injury or death may occur. Should Buyer purchase or use Motorola products for any such unintended or unauthorized application, Buyer shall indemnify and hold Motorola and its officers, employees, subsidiaries, affiliates, and distributors harmless against all claims, costs, damages, and expenses, and reasonable attorney fees arising out of, directly or indirectly, any claim of personal injury or death associated with such unintended or unauthorized use, even if such claim alleges that Motorola was negligent regarding the design or manufacture of the part.

MOTOROLA and the Stylized M Logo are registered in the US Patent and Trademark Office. All other product or service names are the property of their respective owners. Motorola, Inc. is an Equal Opportunity/Affirmative Action Employer.

© Motorola Inc. 2003

MC68HC908LJ24/D  
Rev. 2  
8/2003

**For More Information On This Product,  
Go to: [www.freescale.com](http://www.freescale.com)**