

VI TELEFILTER**Filter Specification****TFS 100F - 1/4****1. Measurement condition**

Ambient temperature T_A :	23 °C		
Input power level:	0 dBm.		
Terminating impedances at f_C :	for input:	57,5 Ω - 23,5 pF.	(typical value.)
	for output:	70,5 Ω - 23 pF.	(typical value.)
Q-value of matching elements:	30		

2. Characteristics

Remark:

Reference level for the relative attenuation a_{rel} of the **TFS 100 F** is the minimum of the pass band attenuation a_{min} . The minimum of the pass band attenuation a_{min} is defined as the insertion loss a_e . The reference frequency f_C is the arithmetic mean value of the upper and lower frequencies at the 33 dB filter attenuation level relative to the insertion loss a_e . The temperature coefficient of frequency T_{Cf} is valid both for the reference frequency f_C and the frequency response of the filter in the operating temperature range.

The bandwidth shift of the filter in the operating temperature range is included in the production tolerance scheme. The frequency shift of the filter in the operating temperature range is not included in the production tolerance scheme.

Data	typ. value	tolerance / limit
Insertion loss (Reference level) a_e	22...22,5 dB	max. 25 dB
Centre frequency f_C at ambient temperature (f_{CTA})	100 MHz	100 \pm 0,1MHz
Pass band :		$f_C - 7,4$ MHz..... $f_C + 7,4$ MHz
Amplitude ripple in pass band (p-p):	0,85..1,0 dB	max. 1,3 dB
Bandwidth at ambient temperature T_A :		
1,3 dB - band width	15,970 MHz	min.14,88 MHz
3 dB - band width	15,115 MHz	min.15,08 MHz
20 dB - band width	15,560 MHz	
33 dB - band width	15,680 MHz	max.15,73 MHz
43 dB - band width	15,900 MHz	max.16,13 MHz
48 dB - band width	16,000 MHz	max.16,93 MHz
Relative attenuation a_{rel}		
f_C	$f_C \pm 7,4$ MHz	-
$f_C \pm 7,4$ MHz	$f_C \pm 7,5$ MHz	max. 1,3 dB
$f_C \pm 7,9$ MHz	$f_C \pm 8,1$ MHz	max. 3 dB
$f_C \pm 8,1$ MHz	$f_C \pm 8,5$ MHz	min. 33 dB
$f_C \pm 8,5$ MHz	$f_C \pm 22,9$ MHz	min. 43 dB
$f_C \pm 22,9$ MHz	$f_C \pm 95$ MHz	min. 48 dB
		54 dB
		50 dB
		54...60 dB
Group delay (mean value in pass band) :	3,47 μ s	max. 3,55 μ s
Group delay ripple in pass band (p-p) :	140...155 ns	max. 170 ns
Deviation from linear phase in pass band:	8°-(p-p) 1,7°-(r.m.s.)	
Input/Output return loss with matching network (S11/S22):	4 / 4 dB	
Triple transit attenuation compared to main signal	50 dB	
Crosstalk attenuation compared to main signal	65..70 dB	
Temperature coefficient of frequency (T_{Cf})	-87 ppm/K	
Frequency deviation of f_C over temperature	$\Delta f_C(\text{Hz}) = T_{Cf}(\text{ppm/K}) \times (T - T_A) \times f_{CTA} (\text{MHz})$	
Operating temperature range	- 25 °C ... + 80 °C	
Storage temperature range	- 40 °C ... + 85 °C	

Generated:**Dunzow W.****Checked / Approved :****Dr. Wall**

VI TELEFILTER
 Potsdamer Straße 18
 D 14 513 TELTOW / Germany
 Tel: (+49) 3328 4784-52 / Fax: (+49) 3328 4784-30
 E-Mail: tft@telefilter.com

Vectron International, Inc.
 267 Lowell Road
 Hudson, NH 03051 / USA
 Tel: (603) 598-0070 Fax: (603) 598-0075
 E-Mail: vti@vtinh.com

VI TELEFILTER reserves the right to make changes to the product(s) and/or information contained herein without notice. No liability is assumed as a result of their use or application. No rights under any patent accompany the sale of any such product(s) or information.

3. Package,

(All dimensions in mm)

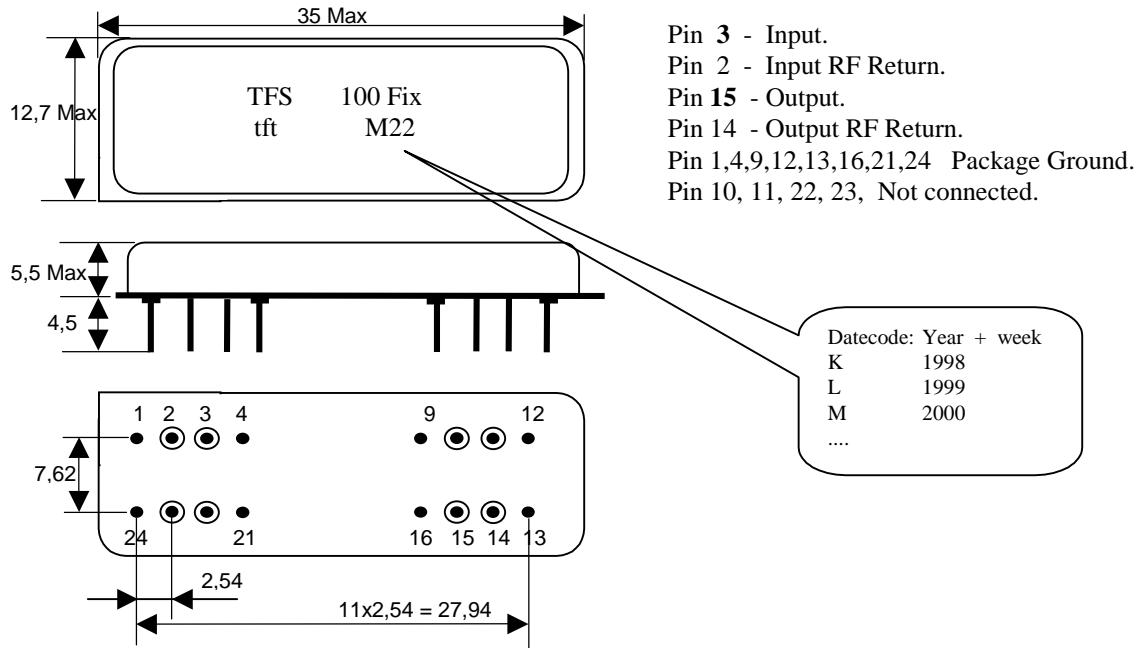
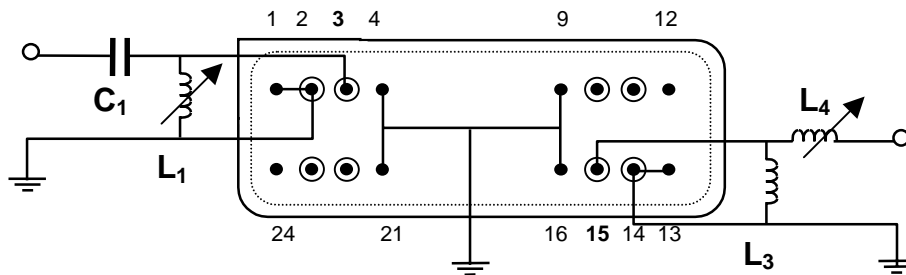
4. 50 Ω - Matching network (see Application Note):

5. Air reflow temperature conditions

1st and 2nd air reflow profile

Name:	pre-heating periods	main-heating periods	peak temperature
Temperature:	150 °C - 170 °C	over 200 °C	255 °C ± 5 °C
Time:	60 sec. - 90 sec.	20 sec. - 25 sec.	

Air reflow profile

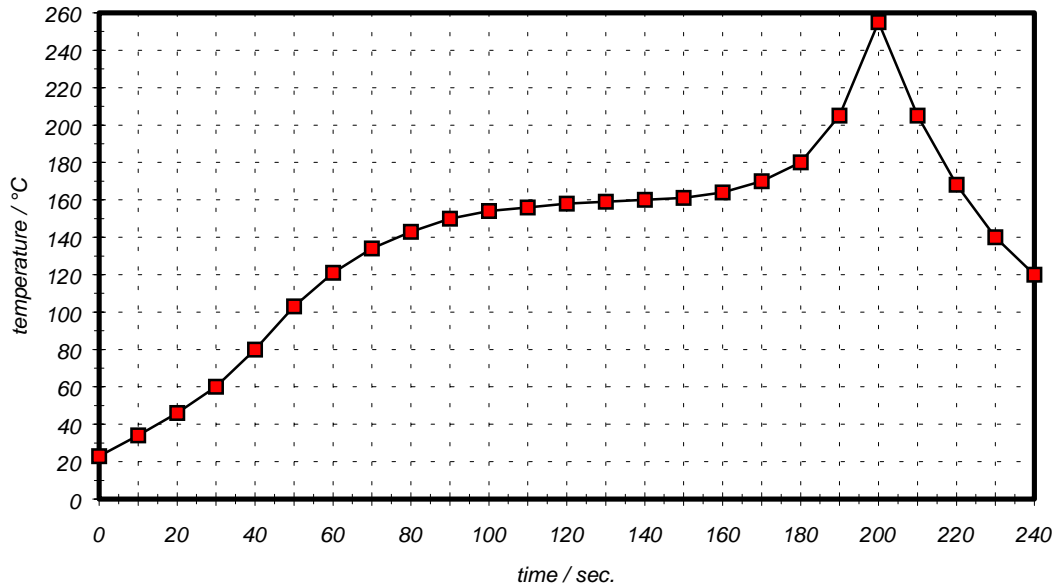

Table for temperature vs. time during the air reflow process

Tolerance of temperatures: ± 5 °C

time / sec.	temperature / °C	time / sec.	temperature / °C
0	23	140	160
10	34	150	161
20	46	160	164
30	60	170	170
40	80	180	180
50	103	190	205
60	121	195	230
70	134	200	255
80	143	205	230
90	150	210	205
100	154	215	180
110	156	220	165
120	158	230	140
130	159	240	120

VI TELEFILTER**Filter Specification****TFS 100F - 4/4**

History

Version	Reason of Changes	Name	Date
1.0	- edit filter specifications TFS 100F according to customer requirements.	Dunzow W.	24.02.2000.
1.1	- edit typical values; - add matching network; - add termination impedance - change limit value of group delay ripple in pass band from max.150 ns to max.170 ns.	Dunzow W.	24.05.2000.

VI TELEFILTER
Potsdamer Straße 18
D 14 513 TELTOW / Germany
Tel: (+49) 3328 4784-52 / Fax: (+49) 3328 4784-30
E-Mail: tft@telefilter.com

Vectron International, Inc.
267 Lowell Road
Hudson, NH 03051 / USA
Tel: (603) 598-0070 Fax: (603) 598-0075
E-Mail: vti@vtinh.com

VI TELEFILTER reserves the right to make changes to the product(s) and/or information contained herein without notice. No liability is assumed as a result of their use or application. No rights under any patent accompany the sale of any such product(s) or information.