

CAN controller interface

PCA82C250

FEATURES

- Fully compatible with the "ISO 11898" standard
- High speed (up to 1 Mbaud)
- Bus lines protected against transients in an automotive environment
- Slope control to reduce Radio Frequency Interference (RFI)
- Differential receiver with wide common-mode range for high immunity against ElectroMagnetic Interference (EMI)
- Thermally protected
- Short-circuit proof to battery and ground
- Low-current standby mode
- An unpowered node does not disturb the bus lines
- At least 110 nodes can be connected.

APPLICATIONS

- High-speed applications (up to 1 Mbaud) in cars.

GENERAL DESCRIPTION

The PCA82C250 is the interface between the CAN protocol controller and the physical bus. The device provides differential transmit capability to the bus and differential receive capability to the CAN controller.

QUICK REFERENCE DATA

SYMBOL	PARAMETER	CONDITIONS	MIN.	MAX.	UNIT
V _{CC}	supply voltage		4.5	5.5	V
I _{CC}	supply current	standby mode	–	170	μA
1/t _{bit}	maximum transmission speed	non-return-to-zero	1	–	Mbaud
V _{CAN}	CANH, CANL input/output voltage		–8	+18	V
V _{diff}	differential bus voltage		1.5	3.0	V
t _{PD}	propagation delay	high-speed mode	–	50	ns
T _{amb}	ambient temperature		–40	+125	°C

ORDERING INFORMATION

TYPE NUMBER	PACKAGE		
	NAME	DESCRIPTION	CODE
PCA82C250	DIP8	plastic dual in-line package; 8 leads (300 mil)	SOT97-1
PCA82C250T	SO8	plastic small outline package; 8 leads; body width 3.9 mm	SOT96-1
PCA82C250U	–	bare die; 2790 × 1780 × 380 μm	–

CAN controller interface

PCA82C250

BLOCK DIAGRAM

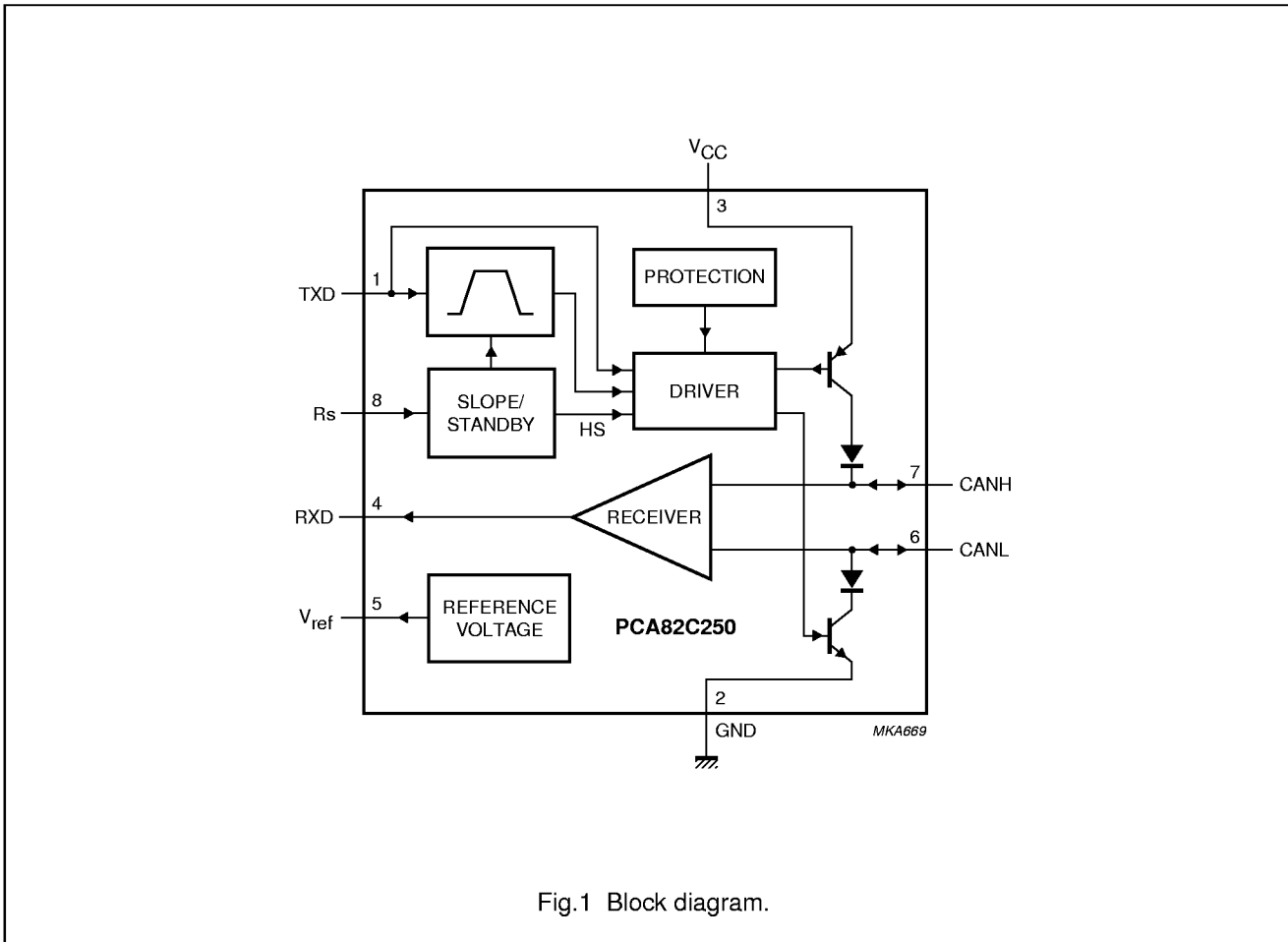

Fig.1 Block diagram.

PINNING

SYMBOL	PIN	DESCRIPTION
TXD	1	transmit data input
GND	2	ground
V _{CC}	3	supply voltage
RXD	4	receive data output
V _{ref}	5	reference voltage output
CANL	6	LOW-level CAN voltage input/output
CANH	7	HIGH-level CAN voltage input/output
Rs	8	slope resistor input

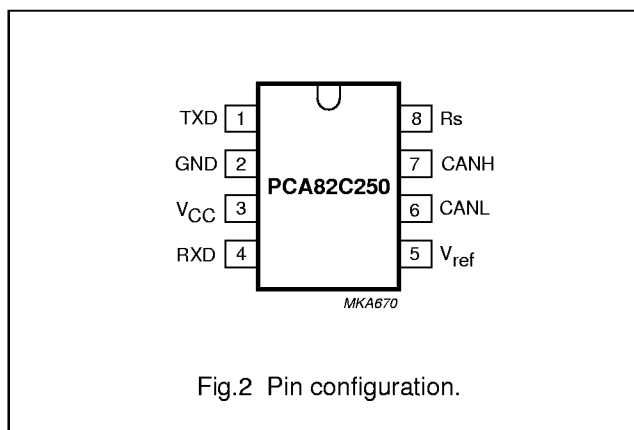

Fig.2 Pin configuration.

CAN controller interface

PCA82C250

FUNCTIONAL DESCRIPTION

The PCA82C250 is the interface between the CAN protocol controller and the physical bus. It is primarily intended for high-speed applications (up to 1 Mbaud) in cars. The device provides differential transmit capability to the bus and differential receive capability to the CAN controller. It is fully compatible with the "ISO 11898" standard.

A current limiting circuit protects the transmitter output stage against short-circuit to positive and negative battery voltage. Although the power dissipation is increased during this fault condition, this feature will prevent destruction of the transmitter output stage.

If the junction temperature exceeds a value of approximately 160 °C, the limiting current of both transmitter outputs is decreased. Because the transmitter is responsible for the major part of the power dissipation, this will result in a reduced power dissipation and hence a lower chip temperature. All other parts of the IC will remain in operation. The thermal protection is particularly needed when a bus line is short-circuited.

The CANH and CANL lines are also protected against electrical transients which may occur in an automotive environment.

Pin 8 (Rs) allows three different modes of operation to be selected: high-speed, slope control or standby.

For high-speed operation, the transmitter output transistors are simply switched on and off as fast as possible. In this mode, no measures are taken to limit the rise and fall slope. Use of a shielded cable is recommended to avoid RFI problems. The high-speed mode is selected by connecting pin 8 to ground.

For lower speeds or shorter bus length, an unshielded twisted pair or a parallel pair of wires can be used for the bus. To reduce RFI, the rise and fall slope should be limited. The rise and fall slope can be programmed with a resistor connected from pin 8 to ground. The slope is proportional to the current output at pin 8.

If a HIGH level is applied to pin 8, the circuit enters a low current standby mode. In this mode, the transmitter is switched off and the receiver is switched to a low current. If dominant bits are detected (differential bus voltage >0.9 V), RXD will be switched to a LOW level.

The microcontroller should react to this condition by switching the transceiver back to normal operation (via pin 8). Because the receiver is slow in standby mode, the first message will be lost.

Table 1 Truth table of the CAN transceiver

SUPPLY	TXD	CANH	CANL	BUS STATE	RXD
4.5 to 5.5 V	0	HIGH	LOW	dominant	0
4.5 to 5.5 V	1 (or floating)	floating	floating	recessive	1
<2 V (not powered)	X ⁽¹⁾	floating	floating	recessive	X ⁽¹⁾
2 V < V _{CC} < 4.5 V	>0.75V _{CC}	floating	floating	recessive	X ⁽¹⁾
2 V < V _{CC} < 4.5 V	X ⁽¹⁾	floating if V _{Rs} > 0.75V _{CC}	floating if V _{Rs} > 0.75V _{CC}	recessive	X ⁽¹⁾

Note

1. X = don't care.

Table 2 Pin Rs summary

CONDITION FORCED AT PIN Rs	MODE	RESULTING VOLTAGE OR CURRENT AT PIN Rs
V _{Rs} > 0.75V _{CC}	standby	I _{Rs} < 10 μA
-10 μA < I _{Rs} < -200 μA	slope control	0.4V _{CC} < V _{Rs} < 0.6V _{CC}
V _{Rs} < 0.3V _{CC}	high-speed	I _{Rs} < -500 μA

CAN controller interface

PCA82C250

LIMITING VALUES

In accordance with the Absolute Maximum Rating System (IEC 60134); all voltages are referenced to pin 2; positive input current.

SYMBOL	PARAMETER	CONDITIONS	MIN.	MAX.	UNIT
V_{CC}	supply voltage		-0.3	+9.0	V
V_n	DC voltage at pins 1, 4, 5 and 8		-0.3	$V_{CC} + 0.3$	V
$V_{6,7}$	DC voltage at pins 6 and 7	$0\text{ V} < V_{CC} < 5.5\text{ V}$; no time limit	-8.0	+18.0	V
V_{trt}	transient voltage at pins 6 and 7	see Fig.8	-150	+100	V
T_{stg}	storage temperature		-55	+150	°C
T_{amb}	ambient temperature		-40	+125	°C
T_{vj}	virtual junction temperature	note 1	-40	+150	°C
V_{esd}	electrostatic discharge voltage	note 2	-2000	+2000	V
		note 3	-200	+200	V

Notes

- In accordance with "IEC 60747-1". An alternative definition of virtual junction temperature is:
 $T_{vj} = T_{amb} + P_d \times R_{th(j-a)}$, where $R_{th(j-a)}$ is a fixed value to be used for the calculation of T_{vj} . The rating for T_{vj} limits the allowable combinations of power dissipation (P_d) and ambient temperature (T_{amb}).
- Classification A: human body model; C = 100 pF; R = 1 500 Ω ; V = ± 2000 V.
- Classification B: machine model; C = 200 pF; R = 25 Ω ; V = ± 200 V.

THERMAL CHARACTERISTICS

SYMBOL	PARAMETER	CONDITIONS	VALUE	UNIT
$R_{th(j-a)}$	thermal resistance from junction to ambient	in free air		
	PCA82C250		100	K/W
	PCA82C250T		160	K/W

QUALITY SPECIFICATION

According to "SNW-FQ-611 part E".

CAN controller interface

PCA82C250

CHARACTERISTICS

$V_{CC} = 4.5$ to 5.5 V; $T_{amb} = -40$ to $+125$ °C; $R_L = 60$ Ω ; $I_g > -10$ μ A; unless otherwise specified; all voltages referenced to ground (pin 2); positive input current; all parameters are guaranteed over the ambient temperature range by design, but only 100% tested at $+25$ °C.

SYMBOL	PARAMETER	CONDITIONS	MIN.	TYP.	MAX.	UNIT
Supply						
I_3	supply current	dominant; $V_1 = 1$ V	–	–	70	mA
		recessive; $V_1 = 4$ V; $R_8 = 47$ k Ω	–	–	14	mA
		recessive; $V_1 = 4$ V; $V_8 = 1$ V	–	–	18	mA
		standby; $T_{amb} < 90$ °C; note 1	–	100	170	μ A
DC bus transmitter						
V_{IH}	HIGH-level input voltage	output recessive	$0.7V_{CC}$	–	$V_{CC} + 0.3$	V
V_{IL}	LOW-level input voltage	output dominant	–0.3	–	$0.3V_{CC}$	V
I_{IH}	HIGH-level input current	$V_1 = 4$ V	–200	–	+30	μ A
I_{IL}	LOW-level input current	$V_1 = 1$ V	–100	–	–600	μ A
$V_{6,7}$	recessive bus voltage	$V_1 = 4$ V; no load	2.0	–	3.0	V
I_{LO}	off-state output leakage current	-2 V $< (V_6, V_7) < 7$ V	–2	–	+1	mA
		-5 V $< (V_6, V_7) < 18$ V	–5	–	+12	mA
V_7	CANH output voltage	$V_1 = 1$ V	2.75	–	4.5	V
V_6	CANL output voltage	$V_1 = 1$ V	0.5	–	2.25	V
$\Delta V_{6,7}$	difference between output voltage at pins 6 and 7	$V_1 = 1$ V	1.5	–	3.0	V
		$V_1 = 1$ V; $R_L = 45$ Ω ; $V_{CC} \geq 4.9$ V	1.5	–	–	V
		$V_1 = 4$ V; no load	–500	–	+50	mV
I_{sc7}	short-circuit CANH current	$V_7 = -5$ V; $V_{CC} \leq 5$ V	–	–	–105	mA
		$V_7 = -5$ V; $V_{CC} = 5.5$ V	–	–	–120	mA
I_{sc6}	short-circuit CANL current	$V_6 = 18$ V	–	–	160	mA
DC bus receiver: $V_1 = 4$ V; pins 6 and 7 externally driven; -2 V $< (V_6, V_7) < 7$ V; unless otherwise specified						
$V_{diff(r)}$	differential input voltage (recessive)		–1.0	–	+0.5	V
		-7 V $< (V_6, V_7) < 12$ V; not standby mode	–1.0	–	+0.4	V
$V_{diff(d)}$	differential input voltage (dominant)		0.9	–	5.0	V
		-7 V $< (V_6, V_7) < 12$ V; not standby mode	1.0	–	5.0	V
$V_{diff(hys)}$	differential input hysteresis	see Fig.5	–	150	–	mV
V_{OH}	HIGH-level output voltage (pin 4)	$I_4 = -100$ μ A	$0.8V_{CC}$	–	V_{CC}	V
V_{OL}	LOW-level output voltage (pin 4)	$I_4 = 1$ mA	0	–	$0.2V_{CC}$	V
		$I_4 = 10$ mA	0	–	1.5	V
R_i	CANH, CANL input resistance		5	–	25	k Ω

CAN controller interface

PCA82C250

SYMBOL	PARAMETER	CONDITIONS	MIN.	TYP.	MAX.	UNIT
R_{diff}	differential input resistance		20	–	100	$k\Omega$
C_i	CANH, CANL input capacitance		–	–	20	μF
C_{diff}	differential input capacitance		–	–	10	μF
Reference output						
V_{ref}	reference output voltage	$V_8 = 1 V$; $-50 \mu A < I_5 < 50 \mu A$	$0.45V_{CC}$	–	$0.55V_{CC}$	V
		$V_8 = 4 V$; $-5 \mu A < I_5 < 5 \mu A$	$0.4V_{CC}$	–	$0.6V_{CC}$	V
Timing (see Figs 4, 6 and 7)						
t_{bit}	minimum bit time	$V_8 = 1 V$	–	–	1	μs
t_{onTXD}	delay TXD to bus active	$V_8 = 1 V$	–	–	50	ns
t_{offTXD}	delay TXD to bus inactive	$V_8 = 1 V$	–	40	80	ns
t_{onRXD}	delay TXD to receiver active	$V_8 = 1 V$	–	55	120	ns
t_{offRXD}	delay TXD to receiver inactive	$V_8 = 1 V$; $V_{CC} < 5.1 V$; $T_{amb} < +85 \text{ }^\circ C$	–	82	150	ns
		$V_8 = 1 V$; $V_{CC} < 5.1 V$; $T_{amb} < +125 \text{ }^\circ C$	–	82	170	ns
		$V_8 = 1 V$; $V_{CC} < 5.5 V$; $T_{amb} < +85 \text{ }^\circ C$	–	90	170	ns
		$V_8 = 1 V$; $V_{CC} < 5.5 V$; $T_{amb} < +125 \text{ }^\circ C$	–	90	190	ns
t_{onRXD}	delay TXD to receiver active	$R_8 = 47 k\Omega$	–	390	520	ns
		$R_8 = 24 k\Omega$	–	260	320	ns
t_{offRXD}	delay TXD to receiver inactive	$R_8 = 47 k\Omega$	–	260	450	ns
		$R_8 = 24 k\Omega$	–	210	320	ns
$ SR $	differential output voltage slew rate	$R_8 = 47 k\Omega$	–	14	–	$V/\mu s$
t_{WAKE}	wake-up time from standby (via pin 8)		–	–	20	μs
t_{dRXDL}	bus dominant to RXD LOW	$V_8 = 4 V$; standby mode	–	–	3	μs
Standby/slope control (pin 8)						
V_8	input voltage for high-speed		–	–	$0.3V_{CC}$	V
I_8	input current for high-speed	$V_8 = 0 V$	–	–	–500	μA
V_{stb}	input voltage for standby mode		$0.75V_{CC}$	–	–	V
I_{slope}	slope control mode current		–10	–	–200	μA
V_{slope}	slope control mode voltage		$0.4V_{CC}$	–	$0.6V_{CC}$	V

Note

- $I_1 = I_4 = I_5 = 0 \text{ mA}$; $0 \text{ V} < V_6 < V_{CC}$; $0 \text{ V} < V_7 < V_{CC}$; $V_8 = V_{CC}$.

CAN controller interface

PCA82C250

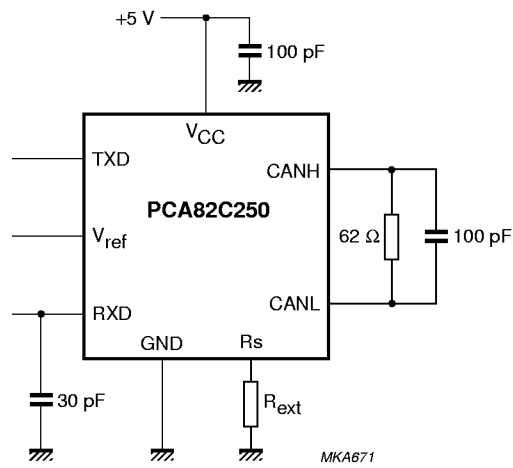

Fig.3 Test circuit for dynamic characteristics.

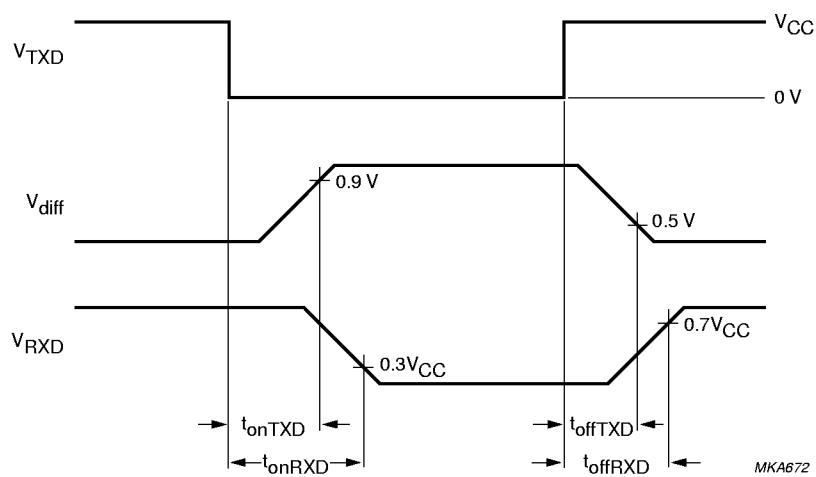

Fig.4 Timing diagram for dynamic characteristics.

CAN controller interface

PCA82C250

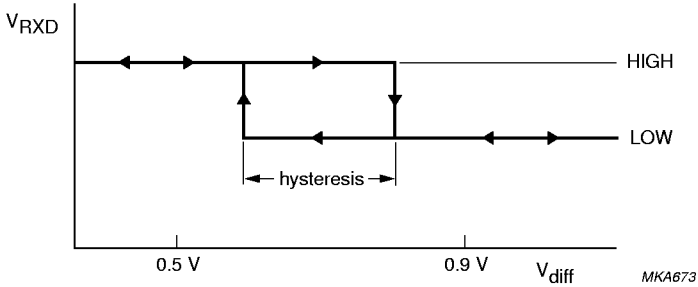
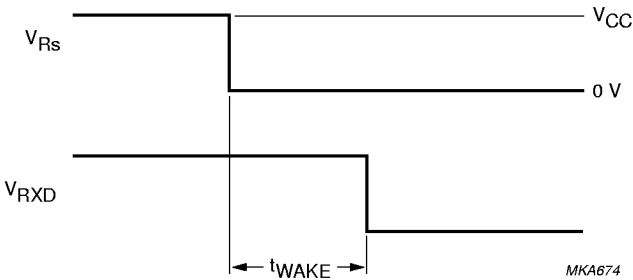

Fig.5 Hysteresis.



$V_1 = 1\text{ V}$.

Fig.6 Timing diagram for wake-up from standby.

CAN controller interface

PCA82C250

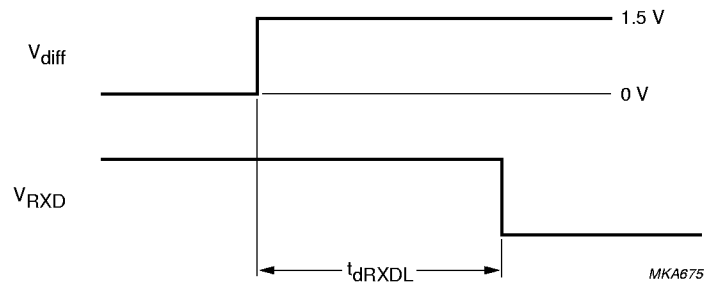

$V_1 = 4\text{ V}; V_8 = 4\text{ V}.$

Fig.7 Timing diagram for bus dominant to RXD LOW.

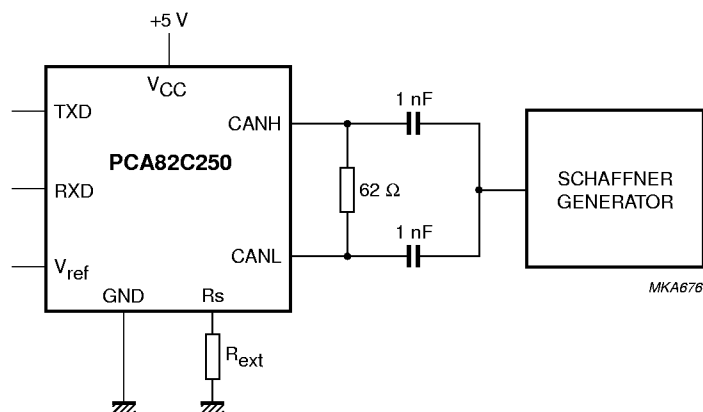

The waveforms of the applied transients shall be in accordance with "ISO 7637 part 1", test pulses 1, 2, 3a and 3b.

Fig.8 Test circuit for automotive transients.

CAN controller interface

PCA82C250

APPLICATION INFORMATION

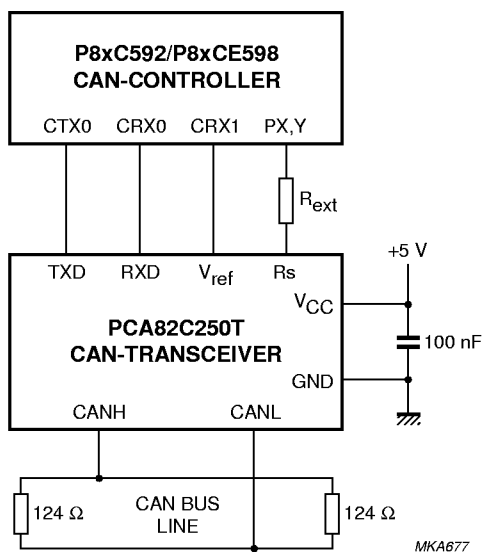

Fig.9 Application of the CAN transceiver.

CAN controller interface

PCA82C250

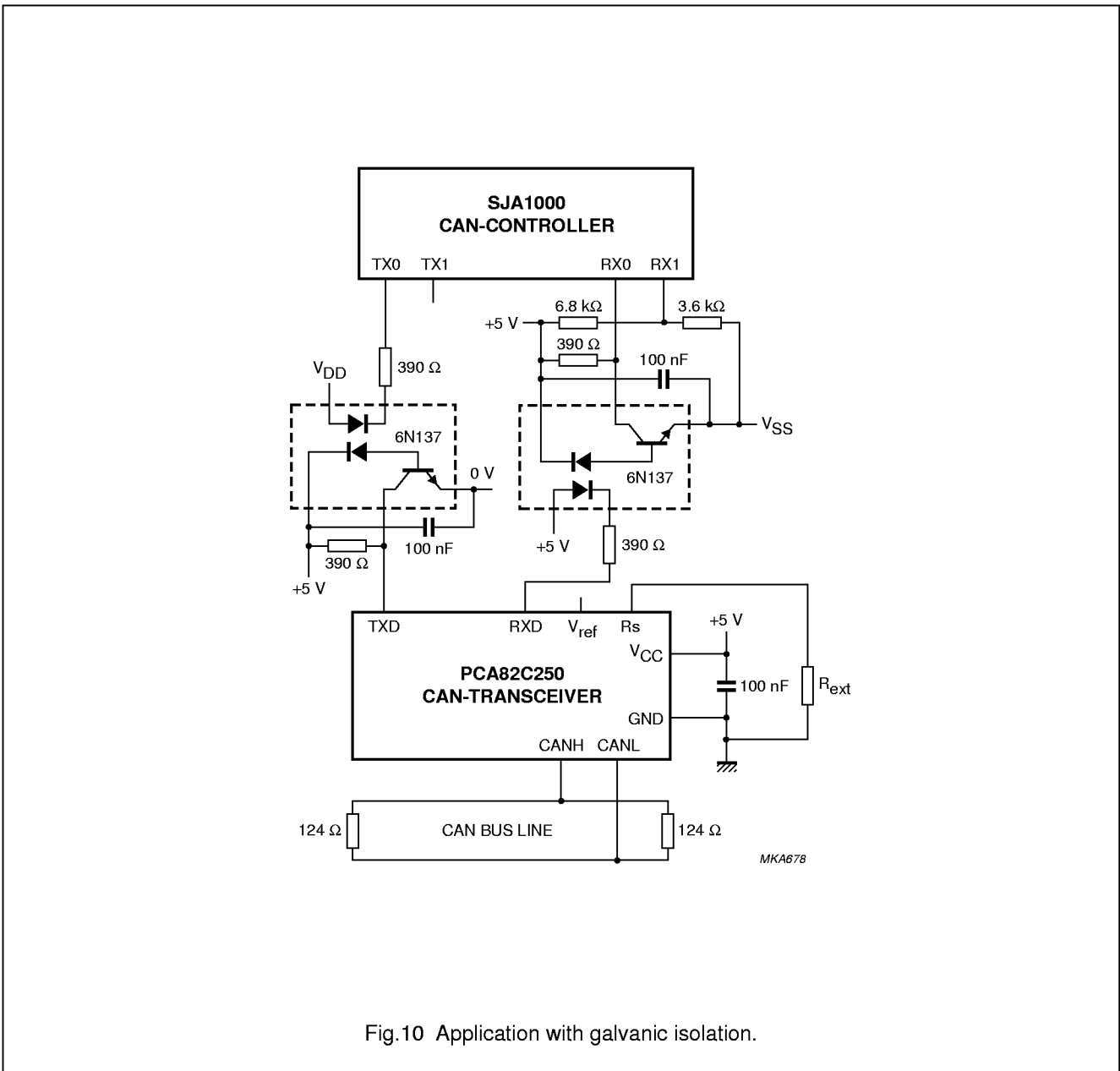

Fig.10 Application with galvanic isolation.

CAN controller interface

PCA82C250

INTERNAL PIN CONFIGURATION

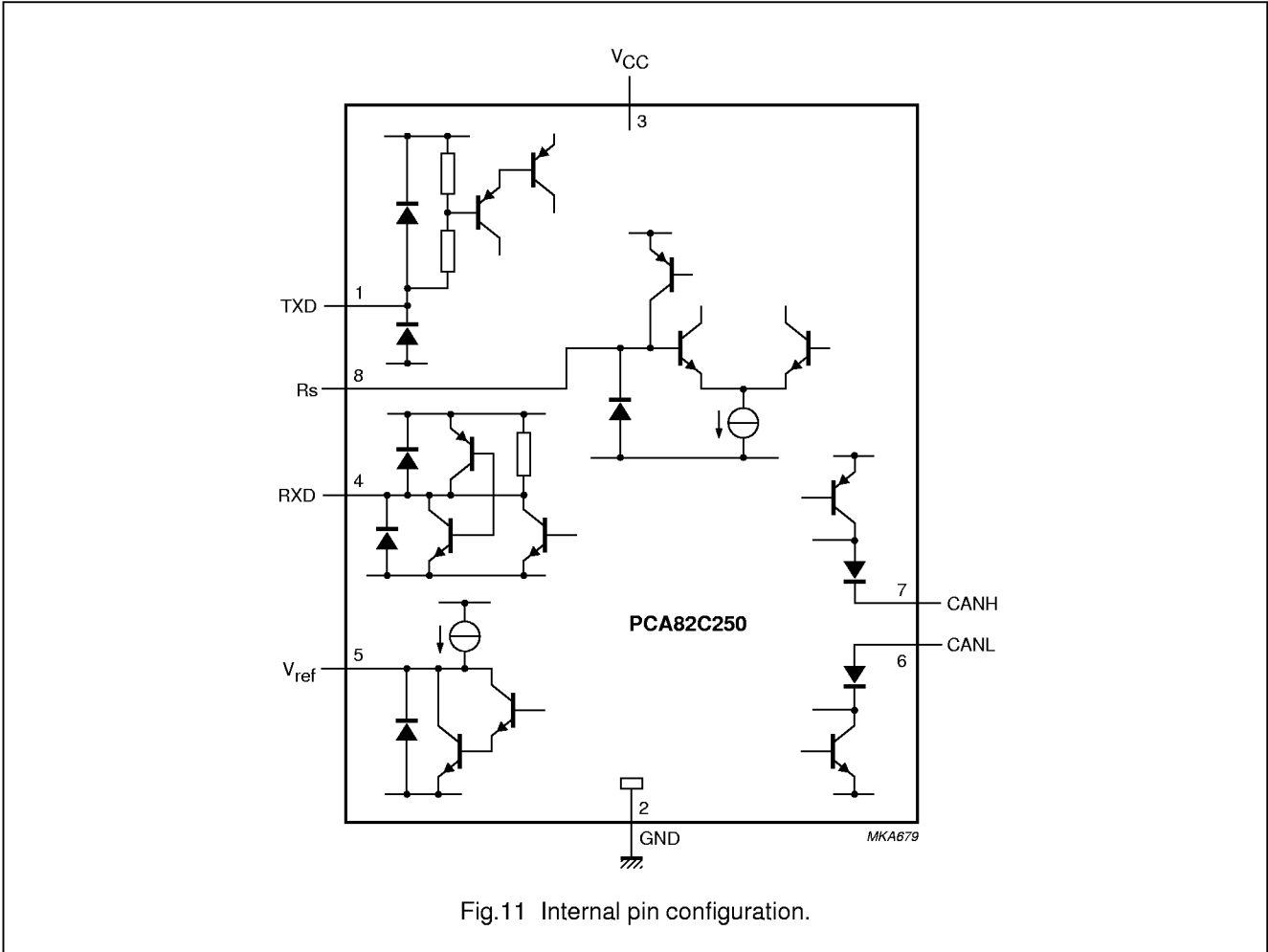

Fig.11 Internal pin configuration.

CAN controller interface

PCA82C250

BONDING PAD LOCATIONS

SYMBOL	PAD	COORDINATES ⁽¹⁾	
		x	y
TXD	1	196	135
GND	2	1280	135
V _{CC}	3	1767	135
RXD	4	2588	135
V _{ref}	5	2594	1640
CANL	6	1689	1640
CANH	7	948	1640
Rs	8	196	1640

Note

1. All coordinates (μm) represent the position of the centre of each pad with respect to the bottom left-hand corner of the die (x/y = 0).

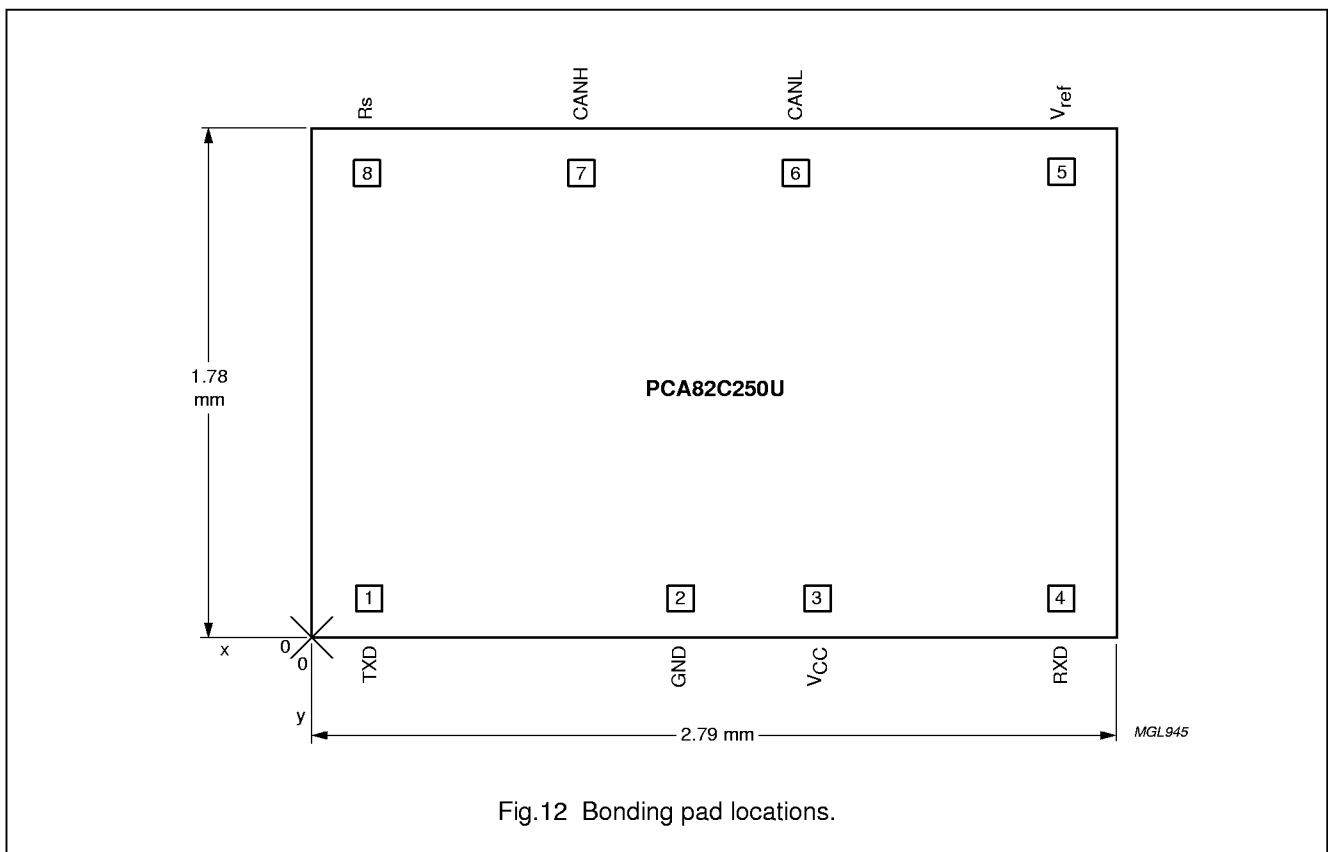

CAN controller interface

PCA82C250

PACKAGE OUTLINES

DIP8: plastic dual in-line package; 8 leads (300 mil)

SOT97-1

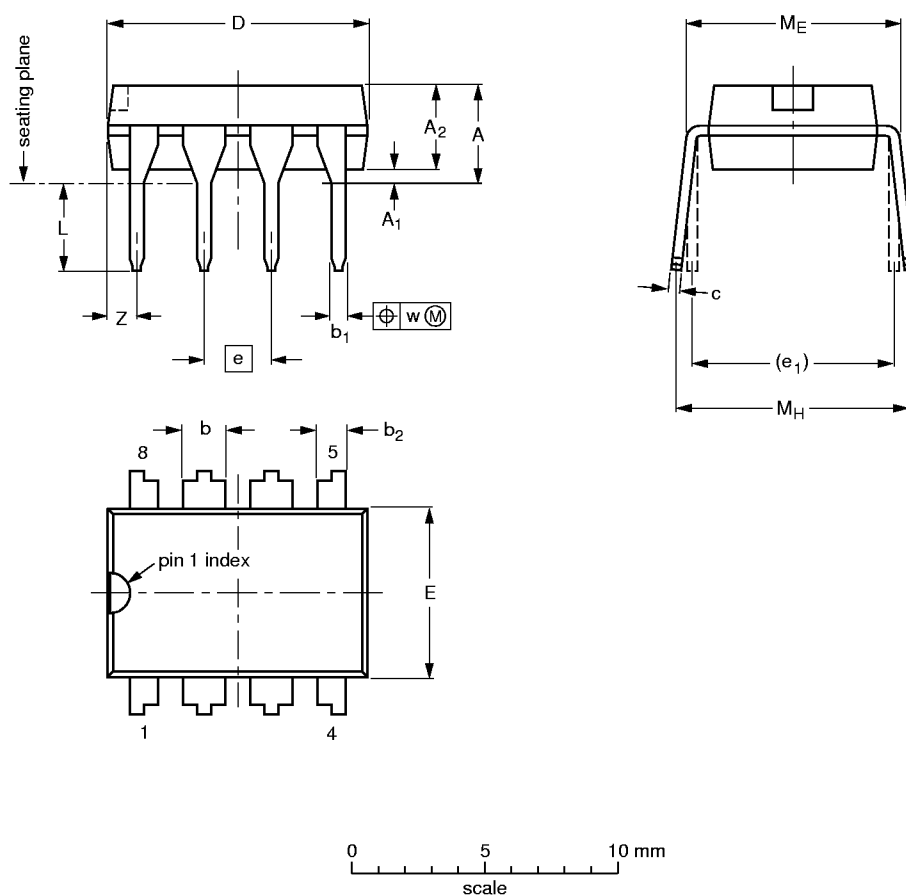

DIMENSIONS (inch dimensions are derived from the original mm dimensions)

UNIT	A max.	A ₁ min.	A ₂ max.	b	b ₁	b ₂	c	D ⁽¹⁾	E ⁽¹⁾	e	e ₁	L	M _E	M _H	w	Z ⁽¹⁾ max.
mm	4.2	0.51	3.2	1.73 1.14	0.53 0.38	1.07 0.89	0.36 0.23	9.8 9.2	6.48 6.20	2.54	7.62	3.60 3.05	8.25 7.80	10.0 8.3	0.254	1.15
inches	0.17	0.020	0.13	0.068 0.045	0.021 0.015	0.042 0.035	0.014 0.009	0.39 0.36	0.26 0.24	0.10	0.30	0.14 0.12	0.32 0.31	0.39 0.33	0.01	0.045

Note

1. Plastic or metal protrusions of 0.25 mm maximum per side are not included.

OUTLINE VERSION	REFERENCES			EUROPEAN PROJECTION	ISSUE DATE
	IEC	JEDEC	EIAJ		
SOT97-1	050G01	MO-001	SC-504-8		95-02-04 99-12-27

CAN controller interface

PCA82C250

SO8: plastic small outline package; 8 leads; body width 3.9 mm

SOT96-1

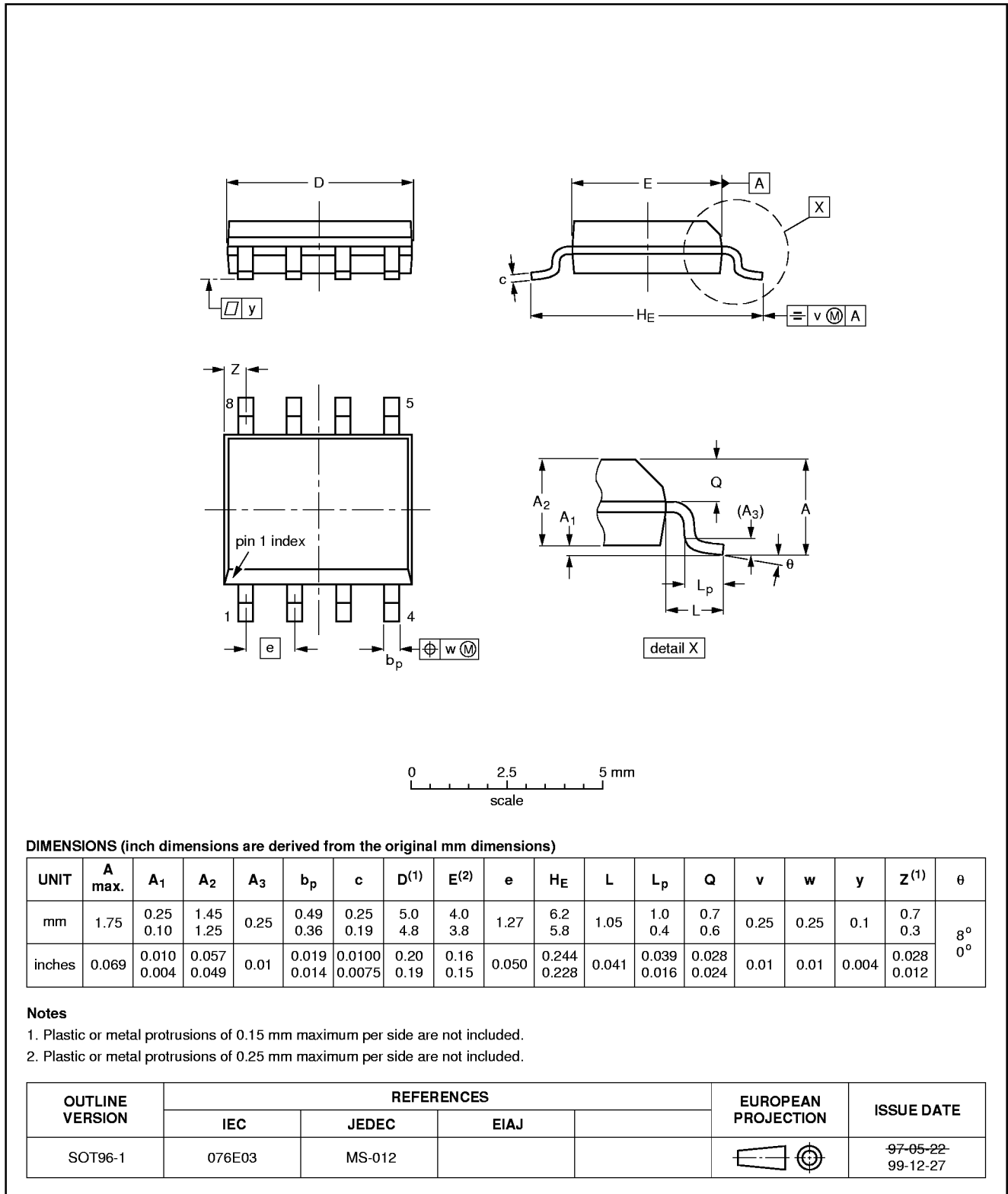

CAN controller interface

PCA82C250

SOLDERING

Introduction

This text gives a very brief insight to a complex technology. A more in-depth account of soldering ICs can be found in our *"Data Handbook IC26; Integrated Circuit Packages"* (document order number 9398 652 90011).

There is no soldering method that is ideal for all IC packages. Wave soldering is often preferred when through-hole and surface mount components are mixed on one printed-circuit board. However, wave soldering is not always suitable for surface mount ICs, or for printed-circuit boards with high population densities. In these situations reflow soldering is often used.

Through-hole mount packages

SOLDERING BY DIPPING OR BY SOLDER WAVE

The maximum permissible temperature of the solder is 260 °C; solder at this temperature must not be in contact with the joints for more than 5 seconds. The total contact time of successive solder waves must not exceed 5 seconds.

The device may be mounted up to the seating plane, but the temperature of the plastic body must not exceed the specified maximum storage temperature ($T_{stg(max)}$). If the printed-circuit board has been pre-heated, forced cooling may be necessary immediately after soldering to keep the temperature within the permissible limit.

MANUAL SOLDERING

Apply the soldering iron (24 V or less) to the lead(s) of the package, either below the seating plane or not more than 2 mm above it. If the temperature of the soldering iron bit is less than 300 °C it may remain in contact for up to 10 seconds. If the bit temperature is between 300 and 400 °C, contact may be up to 5 seconds.

Surface mount packages

REFLOW SOLDERING

Reflow soldering requires solder paste (a suspension of fine solder particles, flux and binding agent) to be applied to the printed-circuit board by screen printing, stencilling or pressure-syringe dispensing before package placement.

Several methods exist for reflowing; for example, infrared/convection heating in a conveyor type oven. Throughput times (preheating, soldering and cooling) vary between 100 and 200 seconds depending on heating method.

Typical reflow peak temperatures range from 215 to 250 °C. The top-surface temperature of the packages should preferably be kept below 230 °C.

WAVE SOLDERING

Conventional single wave soldering is not recommended for surface mount devices (SMDs) or printed-circuit boards with a high component density, as solder bridging and non-wetting can present major problems.

To overcome these problems the double-wave soldering method was specifically developed.

If wave soldering is used the following conditions must be observed for optimal results:

- Use a double-wave soldering method comprising a turbulent wave with high upward pressure followed by a smooth laminar wave.
- For packages with leads on two sides and a pitch (e):
 - larger than or equal to 1.27 mm, the footprint longitudinal axis is **preferred** to be parallel to the transport direction of the printed-circuit board;
 - smaller than 1.27 mm, the footprint longitudinal axis **must** be parallel to the transport direction of the printed-circuit board.

The footprint must incorporate solder thieves at the downstream end.

- For packages with leads on four sides, the footprint must be placed at a 45° angle to the transport direction of the printed-circuit board. The footprint must incorporate solder thieves downstream and at the side corners.

During placement and before soldering, the package must be fixed with a droplet of adhesive. The adhesive can be applied by screen printing, pin transfer or syringe dispensing. The package can be soldered after the adhesive is cured.

Typical dwell time is 4 seconds at 250 °C.

A mildly-activated flux will eliminate the need for removal of corrosive residues in most applications.

MANUAL SOLDERING

Fix the component by first soldering two diagonally-opposite end leads. Use a low voltage (24 V or less) soldering iron applied to the flat part of the lead. Contact time must be limited to 10 seconds at up to 300 °C.

When using a dedicated tool, all other leads can be soldered in one operation within 2 to 5 seconds between 270 and 320 °C.

CAN controller interface

PCA82C250

Suitability of IC packages for wave, reflow and dipping soldering methods

MOUNTING	PACKAGE	SOLDERING METHOD		
		WAVE	REFLOW ⁽¹⁾	DIPPING
Through-hole mount	DBS, DIP, HDIP, SDIP, SIL	suitable ⁽²⁾	–	suitable
Surface mount	BGA, LFBGA, SQFP, TFBGA	not suitable	suitable	–
	HBCC, HLQFP, HSQFP, HSOP, HTQFP, HTSSOP, SMS	not suitable ⁽³⁾	suitable	–
	PLCC ⁽⁴⁾ , SO, SOJ	suitable	suitable	–
	LQFP, QFP, TQFP	not recommended ⁽⁴⁾⁽⁵⁾	suitable	–
	SSOP, TSSOP, VSO	not recommended ⁽⁶⁾	suitable	–

Notes

1. All surface mount (SMD) packages are moisture sensitive. Depending upon the moisture content, the maximum temperature (with respect to time) and body size of the package, there is a risk that internal or external package cracks may occur due to vaporization of the moisture in them (the so called popcorn effect). For details, refer to the Drypack information in the *"Data Handbook IC26; Integrated Circuit Packages; Section: Packing Methods"*.
2. For SDIP packages, the longitudinal axis must be parallel to the transport direction of the printed-circuit board.
3. These packages are not suitable for wave soldering as a solder joint between the printed-circuit board and heatsink (at bottom version) can not be achieved, and as solder may stick to the heatsink (on top version).
4. If wave soldering is considered, then the package must be placed at a 45° angle to the solder wave direction. The package footprint must incorporate solder thieves downstream and at the side corners.
5. Wave soldering is only suitable for LQFP, QFP and TQFP packages with a pitch (e) equal to or larger than 0.8 mm; it is definitely not suitable for packages with a pitch (e) equal to or smaller than 0.65 mm.
6. Wave soldering is only suitable for SSOP and TSSOP packages with a pitch (e) equal to or larger than 0.65 mm; it is definitely not suitable for packages with a pitch (e) equal to or smaller than 0.5 mm.