

# Thin Film Chip Resistors Array



RXA Series

MERITEK

## Feature

- Advanced thin film technology
- Extremely low TCR down to  $\pm 10\text{PPM} / ^\circ\text{C}$
- Very tight tolerance down to  $\pm 0.1\%$
- RoHS compliant component, compatible with lead (Pb)-free

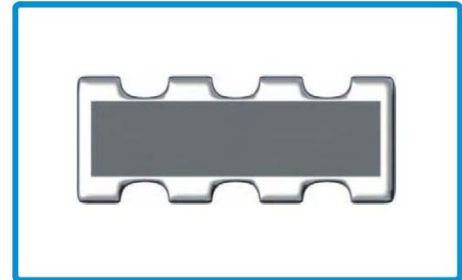

## Part Numbering System

RXA
03
4
D
101
B
C

Thin Film Chip Resistor Array  
 03 (0603)  
 4 (4 circuits)

Code	D
Terminal Type	Convex

Normal Resistance		
Resistors	3- Digit	E24 Series EX 10 $\Omega$ = 100 4.7 $\Omega$ = 4R7
	4- Digit	E24/E96 Series EX 10.2 $\Omega$ = 10R2 10K $\Omega$ = 1002
Jumper		000

Tolerance				
Code	B	C	D	F
Value	$\pm 0.1\%$	$\pm 0.25\%$	$\pm 0.5\%$	$\pm 1\%$

TCR

Code	C	D	F	G
Value	$\pm 10\text{ppm}/^\circ\text{C}$	$\pm 15\text{ppm}/^\circ\text{C}$	$\pm 25\text{ppm}/^\circ\text{C}$	$\pm 50\text{ppm}/^\circ\text{C}$

## Electrical Specifications

Item Type	Power Rating at 70°C	Operating Temp. Range	Max. Operating Voltage	Max. Overload Voltage	Resistance Range				TCR (PPM/°C)
					$\pm 0.1\%$	$\pm 0.25\%$	$\pm 0.5\%$	$\pm 1\%$	
RXA03-4D	1/16	-55 ~ +155°C	50V	100V	100~33K ohm				$\pm 25$
					100~2K ohm				$\pm 10$ $\pm 15$

Operating Voltage =  $\sqrt{P \cdot R}$  or Max. operating voltage listed above, whichever is lower.  
 Overload Voltage =  $2.5 \cdot \sqrt{P \cdot R}$  or Max. overload voltage listed above, whichever is lower.

# Thin Film Chip Resistors Array



RXA Series

MERITEK

## Dimension

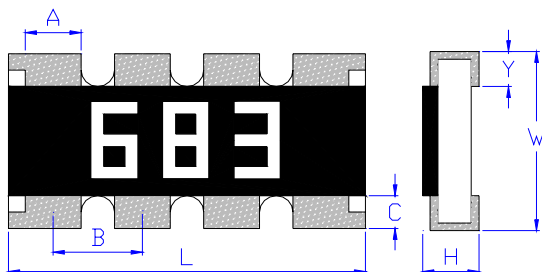

Unit: mm

Type	Number of Resistors	L	W	H	A	B	C	Y
RXA03-4D	4	3.20±0.15	1.60±0.15	0.55±0.10	0.50±0.15	0.80±0.05	0.30±0.15	0.30±0.15

## Environmental Characteristics

Item	Requirement		Test Method
	Tol. ≤ 0.25%	Tol. > 0.25%	
Temperature Coefficient of Resistance (T.C.R.)	As Spec.		MIL-STD-202F Method 304 +25/-55/+25/+125/+25°C
Short Time Overload	ΔR±0.25%	ΔR±0.5%	JIS-C-5201-1 5.5 RCWV*2.5 or Max. overload voltage for 5 seconds
Insulation Resistance	>1000 MΩ		MIL-STD-202F Method 302 Apply 100VDC for 1 minute
Endurance	ΔR±0.25%	ΔR±0.5%	MIL-STD-202F Method 108A 70±2°C, Max. working voltage for 1000 hrs with 1.5 hrs "ON" and 0.5 hrs "OFF"
Damp Heat with Load	ΔR±0.25%	ΔR±0.5%	MIL-STD-202F Method 103B 40±2°C, 90~95% R.H. Max. working voltage for 1000 hrs with 1.5 hrs "ON" and 0.5 hrs "OFF"
Bending Strength	ΔR±0.25%	ΔR±0.5%	JIS-C-5201-1 6.1.4 Bending amplitude 3 mm for 10 seconds
Solderability	95% min. coverage		MIL-STD-202F Method 208H 245±5°C for 3 seconds
Resistance to Soldering Heat	ΔR±0.25%	ΔR±0.5%	MIL-STD-202F Method 210E 260±5°C for 10 seconds
Dielectric Withstand Voltage	100V		MIL-STD-202F Method 301 Max. overload voltage for 1 minute
Thermal Shock	ΔR±0.25%	ΔR±0.5%	MIL-STD-202F Method 107G -55°C ~150°C, 100 cycles
Low Temperature Operation	ΔR±0.25%	ΔR±0.5%	JIS-C-5201-1 7.1 1 hour, -65°C, followed by 45 minutes of RCWV

Storage Temperature: 25±3°C; Humidity < 80%RH

# Thin Film Chip Resistors Array



RXA Series

MERITEK

## Derating Curve

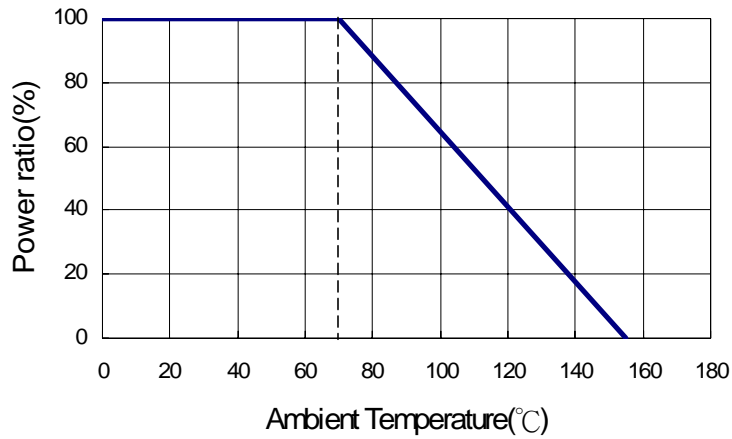

## Reflow Profile

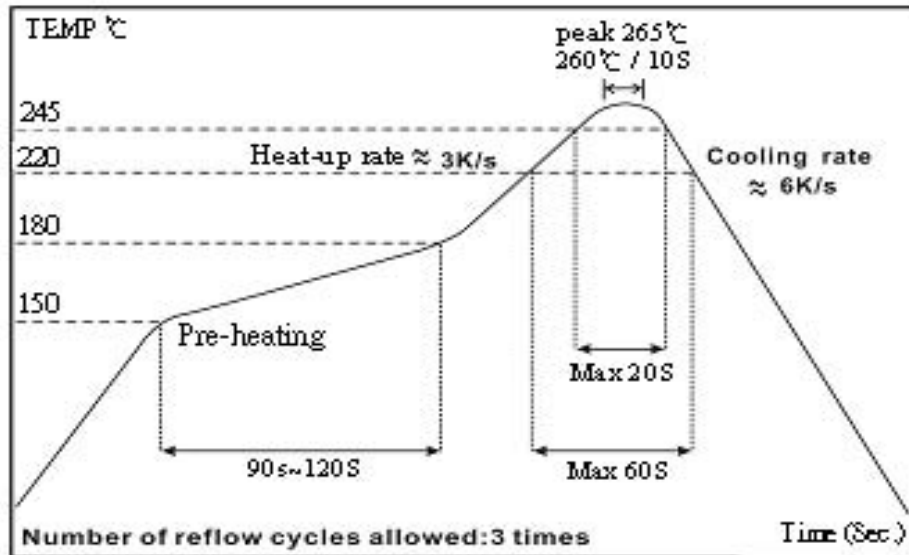

# Thin Film Chip Resistors Array



RXA Series

MERITEK

## Packaging

Reel Specifications & Packaging Quantity

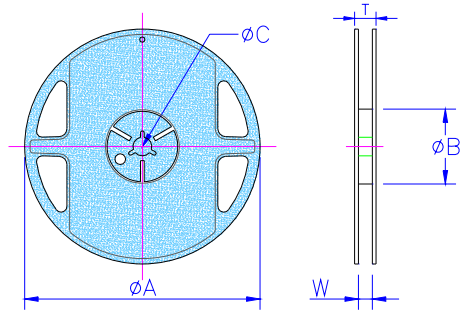

Unit: mm

Type	Packaging Quantity		Tape width	Reel Diameter	ΦA	ΦB	ΦC	W	T
RXA03-4D	Paper	5K	8mm	7 inch	178.5±1.5	60 <sup>+1/-0</sup>	13.0±0.2	9.0±0.5	12.5±0.5

Paper Tape Specification

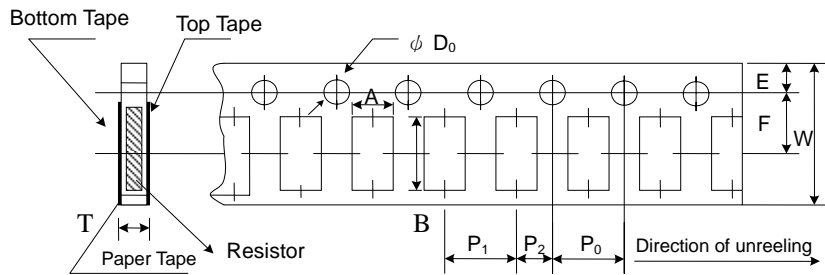

Unit: mm

Type	A	B	W	E	F	P <sub>0</sub>	P <sub>1</sub>	P <sub>2</sub>	ΦD <sub>0</sub>	T
RXA03-4D	1.95±0.1	3.50±0.1	8.0±0.2	1.75±0.1	3.5±0.05	4.0±0.1	4.0±0.05	2.0±0.05	1.5 <sup>+0.1/-0</sup>	0.85±0.1

Recommend Land Pattern

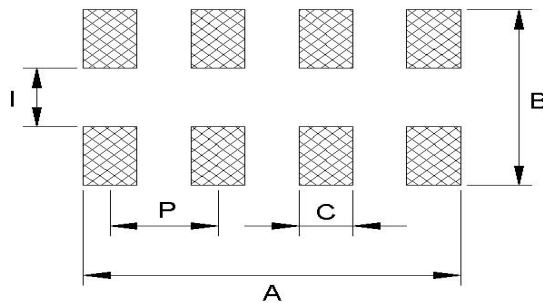

Unit: mm

Type	A	B	C	C1	I	I1	P	P1
RXA03-4D	2.85	3.10	0.45	--	0.80	--	0.80	--