

HI-1573, HI-1574

MIL-STD-1553

3.3V Monolithic Dual Transceivers

DESCRIPTION

The HI-1573 and HI-1574 are low power CMOS dual transceivers designed to meet the requirements of the MIL-STD-1553 specification.

The transmitter section of each channel takes complementary CMOS / TTL digital input data and converts it to bi-phase Manchester encoded 1553 signals suitable for driving the bus isolation transformer. Separate transmitter inhibit control signals are provided for each transmitter.

The receiver section of the each channel converts the 1553 bus bi-phase data to complementary CMOS / TTL data suitable for inputting to a Manchester decoder. Each receiver has a separate enable input which can be used to force the output of the receiver to a logic "0" (HI-1573) or logic 1 (HI-1574).

To minimize the package size for this function, the transmitter outputs are internally connected to the receiver inputs, so that only two pins are required for connection to each coupling transformer. For designs requiring independent access to transmitter and receiver 1553 signals, please contact your Holt Sales representative.

FEATURES

- Compliant to MIL-STD-1553A & B, ARINC 708A
- 3.3V single supply operation
- Smallest footprint available in 20 pin plastic ESOIC (thermally enhanced SOIC) package
- Less than 0.5W maximum power dissipation
- 7 mm x 7 mm 44-pin plastic chip-scale package
- Available in DIP and small outline (ESOIC) package options
- Military processing options
- Industry standard pin configurations

PIN CONFIGURATIONS

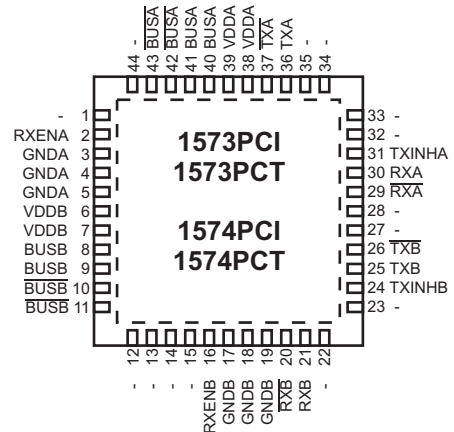

**44 Pin Plastic 7mm x 7mm
Chip-scale package**

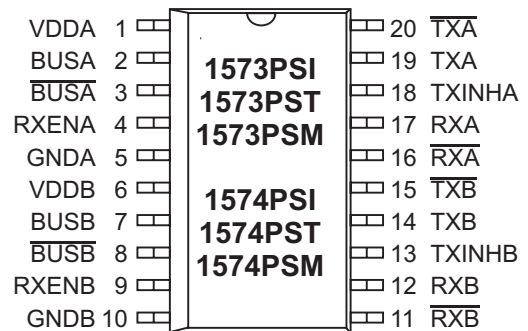

20 Pin Plastic ESOIC - WB package

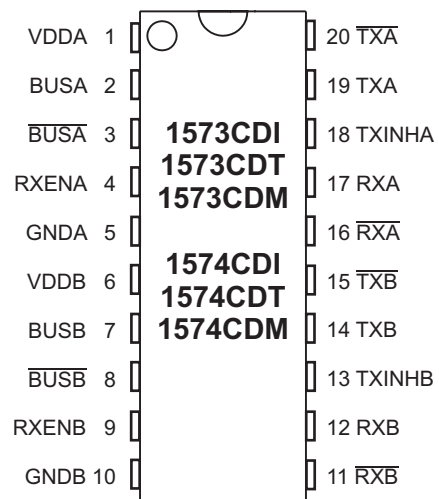

20 Pin Ceramic DIP package

HI-1573, HI-1574

PIN DESCRIPTIONS

PIN (DIP & SOIC)	SYMBOL	FUNCTION	DESCRIPTION
1	VDDA	power supply	+3.3 volt power for transceiver A
2	BUSA	analog output	MIL-STD-1533 bus driver A, positive signal
3	\overline{BUSA}	analog output	MIL-STD-1553 bus driver A, negative signal
4	RXENA	digital input	Receiver A enable. If low, forces RXA and \overline{RXA} low (HI-1573) or High (HI-1574)
5	GNDA	power supply	Ground for transceiver A
6	Vddb	power supply	+3.3 volt power for transceiver B
7	BUSB	analog output	MIL-STD-1533 bus driver B, positive signal
8	\overline{BUSB}	analog output	MIL-STD-1553 bus driver B, negative signal
9	RXENB	digital input	Receiver B enable. If low, forces RXB and \overline{RXB} low (HI-1573) or High (HI-1574)
10	GNDB	power supply	Ground for transceiver B
11	\overline{RXB}	digital output	Receiver B output, inverted
12	RXB	digital output	Receiver B output, non-inverted
13	TXINHb	digital input	Transmit inhibit, bus B. If high BUSB, \overline{BUSB} disabled
14	TXB	digital input	Transmitter B digital data input, non-inverted
15	\overline{TXB}	digital input	Transmitter B digital data input, inverted
16	\overline{RXA}	digital output	Receiver A output, inverted
17	RXA	digital output	Receiver A output, non-inverted
18	TXINHb	digital input	Transmit inhibit, bus A. If high BUSA, \overline{BUSA} disabled
19	TXA	digital input	Transmitter A digital data input, non-inverted
20	\overline{TXA}	digital input	Transmitter A digital data input, inverted

FUNCTIONAL DESCRIPTION

The HI-1573 family of data bus transceivers contains differential voltage source drivers and differential receivers. They are intended for applications using a MIL-STD-1553 A/B data bus. The device produces a trapezoidal output waveform during transmission.

TRANSMITTER

Data input to the device's transmitter section is from the complementary CMOS inputs TXA/B and $\overline{TXA/B}$. The transmitter accepts Manchester II bi-phase data and converts it to differential voltages on BUSA/B and $\overline{BUSA/B}$. The transceiver outputs are either direct or transformer coupled to the MIL-STD-1553 data bus. Both coupling methods produce a nominal voltage on the bus of 7.5 volts peak to peak.

The transmitter is automatically inhibited and placed in the high impedance state when both TXA/B and $\overline{TXA/B}$ are either at a logic "1" or logic "0" simultaneously. A logic "1" applied to the TXINHb input will force the transmitter to the high impedance state, regardless of the state of TXA/B and $\overline{TXA/B}$.

RECEIVER

The receiver accepts bi-phase differential data from the MIL-STD-1553 bus through the same direct or transformer coupled interface as the transmitter. The receiver's differential input stage drives a filter and threshold comparator that produces CMOS data at the RXA/B and $\overline{RXA/B}$ output pins.

Each set of receiver outputs can be independently forced to a logic "0" (HI-1573) or logic "1" (HI-1574) by setting RXENA or RXENB low.

MIL-STD-1553 BUS INTERFACE

A direct coupled interface (see Figure 2) uses a 1:2.5 ratio isolation transformer and two 55 ohm isolation resistors between the transformer and the bus.

In a transformer coupled interface (see Figure 3), the transceiver is connected to a 1:1.79 isolation transformer which in turn is connected to a 1:1.4 coupling transformer. The transformer coupled method also requires two coupling resistors equal to 75% of the bus characteristic impedance (Z_0) between the coupling transformer and the bus.

HI-1573, HI-1574

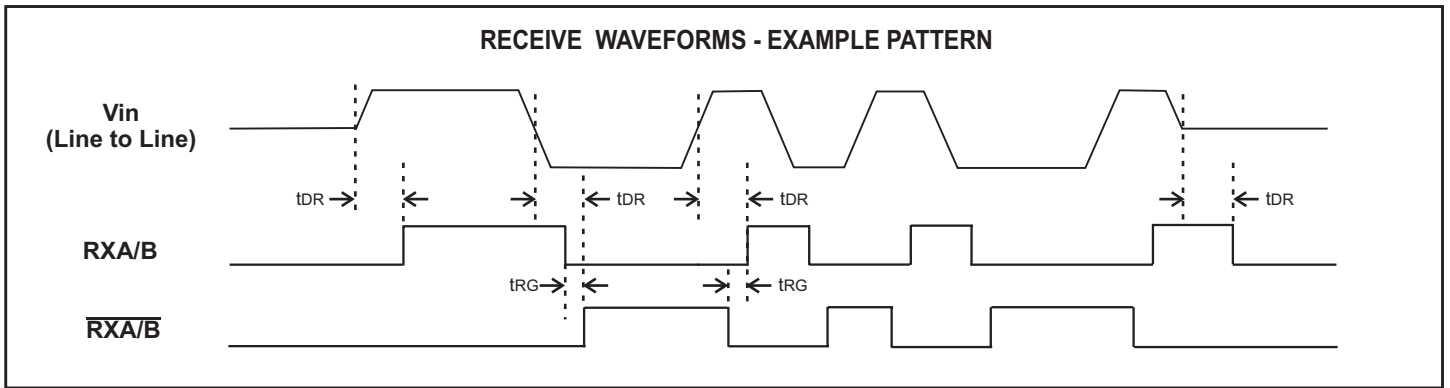
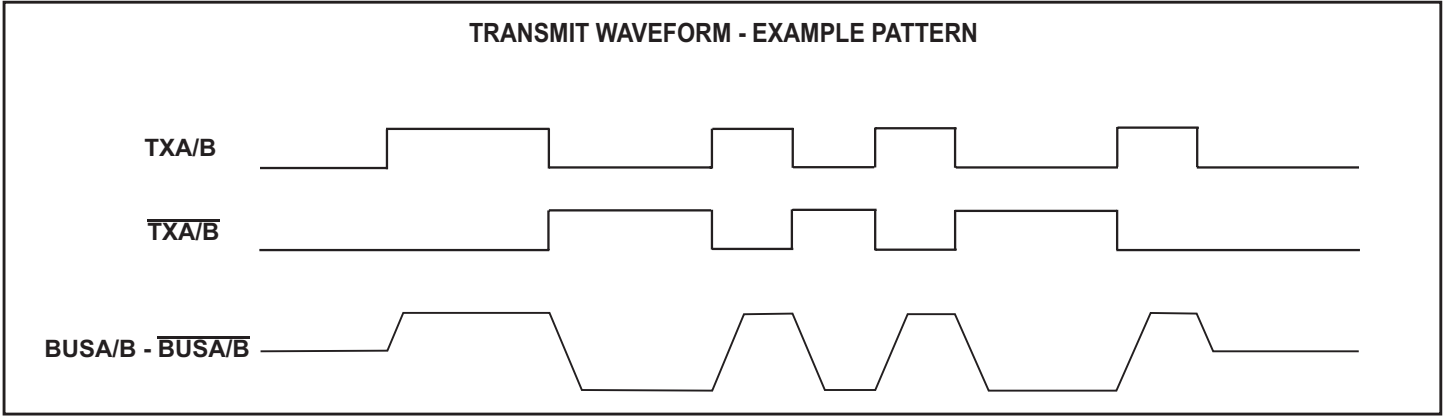
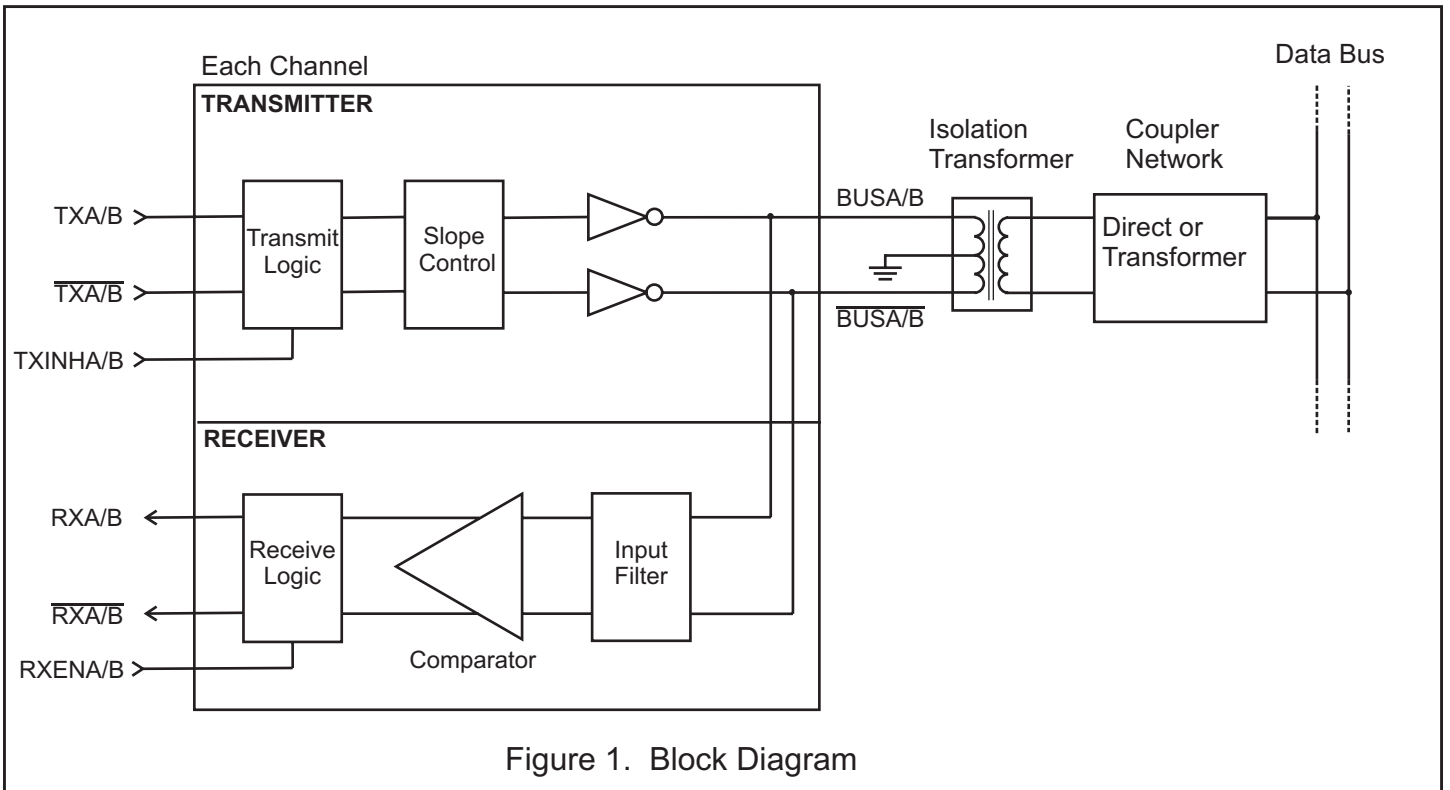

HI-1573, HI-1574

ABSOLUTE MAXIMUM RATINGS

Supply voltage (VDD)	-0.3 V to +5 V
Logic input voltage range	-0.3 V dc to +3.6 V
Receiver differential voltage	10 Vp-p
Driver peak output current	+1.0 A
Power dissipation at 25°C ceramic DIL, derate	1.0 W 7mW/°C
Solder Temperature	275°C for 10 sec.
Junction Temperature	175°C
Storage Temperature	-65°C to +150°C

RECOMMENDED OPERATING CONDITIONS

Supply Voltage
VDD..... 3.3V... ±5%
Temperature Range
Industrial Screening.....-40°C to +85°C
Hi-Temp Screening.....-55°C to +125°C
Military Screening.....-55°C to +125°C

NOTE: Stresses above absolute maximum ratings or outside recommended operating conditions may cause permanent damage to the device. These are stress ratings only. Operation at the limits is not recommended.

DC ELECTRICAL CHARACTERISTICS

VDD = 3.3 V, GND = 0V, TA = Operating Temperature Range (unless otherwise specified).

PARAMETER	SYMBOL	CONDITION	MIN	TYP	MAX	UNITS	
Operating Voltage	VDD		3.15	3.30	3.45	V	
Total Supply Current	ICC1	Not Transmitting		4	10	mA	
	ICC2	Transmit one channel @ 50% duty cycle		225	250	mA	
	ICC3	Transmit one channel @ 100% duty cycle		425	500	mA	
Power Dissipation	PD1	Not Transmitting			0.06	W	
	PD2	Transmit one channel @ 100% duty cycle		0.3	0.5	W	
Min. Input Voltage (HI)	V _{IH}	Digital inputs	70%			VDD	
Max. Input Voltage (LO)	V _{IL}	Digital inputs			30%	VDD	
Min. Input Current (HI)	I _{IH}	Digital inputs			20	µA	
Max. Input Current (LO)	I _{IL}	Digital inputs	-20			µA	
Min. Output Voltage (HI)	V _{OH}	I _{OUT} = -1.0mA, Digital outputs	90%			VDD	
Max. Output Voltage (LO)	V _{OL}	I _{OUT} = 1.0mA, Digital outputs			10%	VDD	
RECEIVER (Measured at Point "Ad" in Figure 2 unless otherwise specified)							
Input resistance	R _{IN}	Differential	20			Kohm	
Input capacitance	C _{IN}	Differential			5	pF	
Common mode rejection ratio	CMRR		40			dB	
Input Level	V _{IN}	Differential			9	Vp-p	
Input common mode voltage	V _{ICM}		-5.0		5.0	V-pk	
Threshold Voltage - Direct-coupled	Detect	V _{THD}	1 Mhz Sine Wave (Measured at Point "Ad" in Figure 2)		1.15	20.0	Vp-p
	No Detect	V _{THND}					
Threshold Voltage - Transformer-coupled	Detect	V _{THD}	1 MHz Sine Wave (Measured at Point "Ar" in Figure 3)		0.86	14.0	Vp-p
	No Detect	V _{THND}					

HI-1573, HI-1574

DC ELECTRICAL CHARACTERISTICS (cont.)

VDD = 3.3 V, GND = 0V, TA = Operating Temperature Range (unless otherwise specified).

PARAMETER	SYMBOL	CONDITION	MIN	TYP	MAX	UNITS	
TRANSMITTER (Measured at Point "Ad" in Figure 2 unless otherwise specified)							
Output Voltage	Direct coupled	V _{OUT}	35 ohm load (Measured at Point "Ad" in Figure 2)	.6.0		9.0	Vp-p
	Transformer coupled	V _{OUT}	70 ohm load (Measured at Point "At" in Figure 3)	.18.0		27.0	Vp-p
Output Noise		V _{ON}	Differential, inhibited			10.0	mVp-p
Output Dynamic Offset Voltage	Direct coupled	V _{DYN}	35 ohm load (Measured at Point "Ad" in Figure 2)	-90		90	mV
	Transformer coupled	V _{DYN}	70 ohm load (Measured at Point "At" in Figure 3)	-250		250	mV
Output resistance		R _{OUT}	Differential, not transmitting	10			Kohm
Output Capacitance		C _{OUT}	1 MHz sine wave			15	pF

AC ELECTRICAL CHARACTERISTICS

VDD = 3.3 V, GND = 0V, TA = Operating Temperature Range (unless otherwise specified).

PARAMETER	SYMBOL	TEST CONDITIONS	MIN	TYP	MAX	UNITS
RECEIVER (Measured at Point "At" in Figure 3)						
Receiver Delay	t _{DR}	From input zero crossing to RXA/B or $\overline{RXA/B}$			500 Note 3	ns
Receiver gap time	t _{RG}	Spacing between RXA/B and $\overline{RXA/B}$ pulses	60 Note 1		430 Note 2	ns
Receiver Enable Delay	t _{REN}	From RXENA/B rising or falling edge to RXA/B or $\overline{RXA/B}$			40	ns
TRANSMITTER (Measured at Point "Ad" in Figure 2)						
Driver Delay	t _{DT}	TXA/B, TXA/B to BUSA/B, BUSA/B			150	ns
Rise time	t _r	35 ohm load	100		300	ns
Fall Time	t _f	35 ohm load	100		300	ns
Inhibit Delay	t _{DI-H}	Inhibited output			100	ns
	t _{DI-L}	Active output			150	ns

Note 1. Measured using a 1 MHz sinusoid, 20 V peak to peak, line to line at point "AT" (Guaranteed but not tested).

Note 2. Measured using a 1 MHz sinusoid, 860 mV peak to peak, line to line at point "AT" (100% tested).

Note 3. Measured using a 1 MHz sinusoid, 860 mV peak to peak, line to line at point "AT". Measured from input zero crossing point.

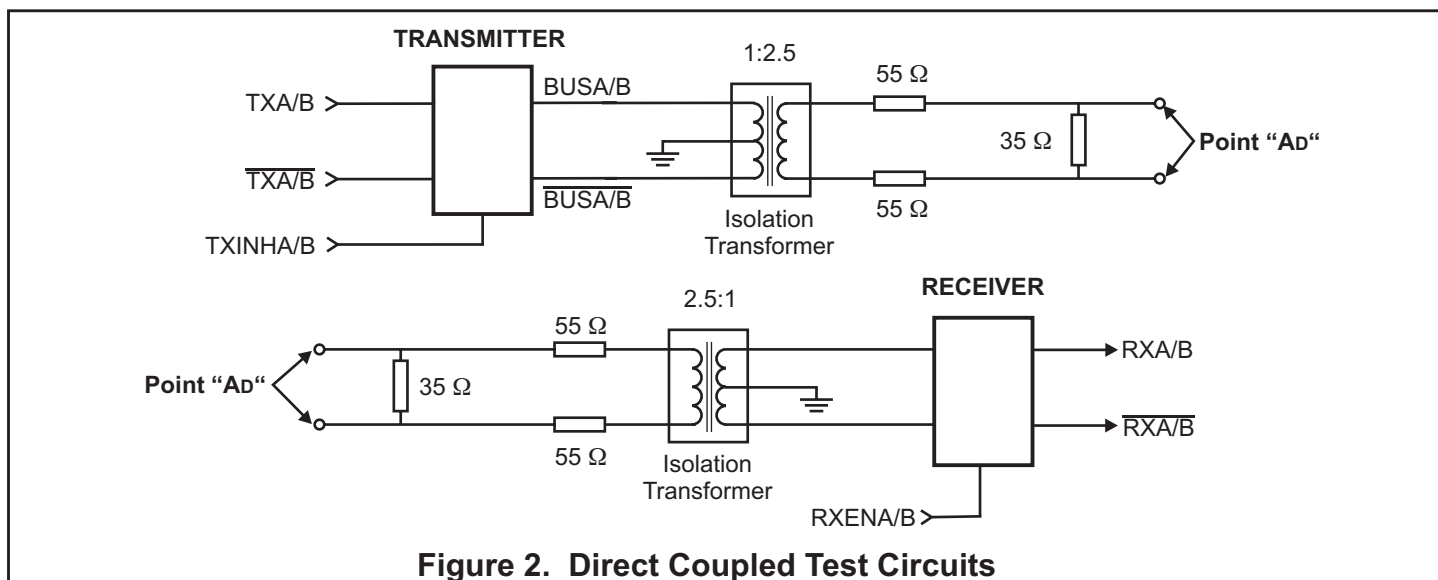

Figure 2. Direct Coupled Test Circuits

HI-1573, HI-1574

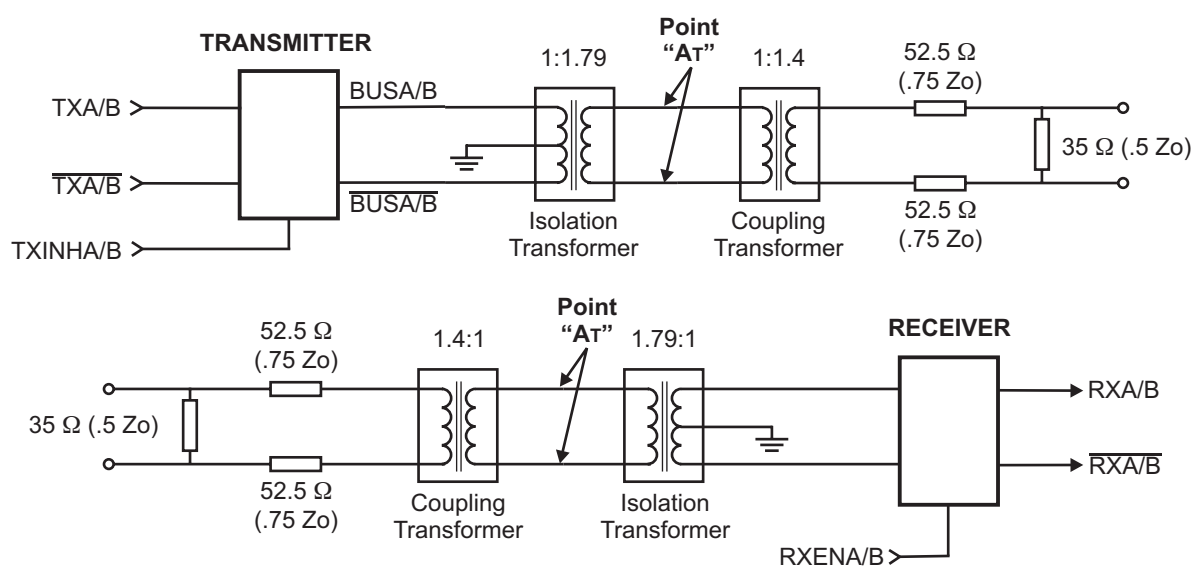

Figure 3. Transformer Coupled Test Circuits

HEAT SINK - ESOIC & CHIP-SCALE PACKAGE

Both the HI-1573PSI/T/M and HI-1574PSI/T/M use a 20-pin thermally enhanced SOIC package. The HI-1573PCI/T and HI-1574PCI/T use a plastic chip-scale package. These packages include a metal heat sink located on the bottom surface of the device. This heat sink should be soldered down to the printed circuit board for optimum thermal dissipation. The heat sink is electrically isolated and may be soldered to any convenient power or ground plane..

APPLICATIONS NOTE

Holt Applications Note AN-500 provides circuit design notes regarding the use of Holt's family of MIL-STD-1553 transceivers. Layout considerations, as well as recommended interface and protection components are included.

THERMAL CHARACTERISTICS

PART NUMBER	PACKAGE STYLE	CONDITION	θ_{JA}	JUNCTION TEMPERATURE		
				$T_A=25^\circ\text{C}$	$T_A=85^\circ\text{C}$	$T_A=125^\circ\text{C}$
HI-1573PSI / T / M	20-pin Thermally enhanced plastic SOIC (ESOIC)	Heat sink unsoldered	54°C/W	52°C	112°C	152°C
HI-1574PSI / T / M		Heat sink soldered	47°C/W	49°C	109°C	149°C
HI-1573CDI / T / M HI-1574CDI / T / M	20-pin Ceramic side-brazed DIP	Socketed	62°C/W	56°C	116°C	156°C
HI-1573PCI / T HI-1574PCI / T	44-pin Plastic chip-scale package	Heat sink unsoldered	49°C/W	50°C	110°C	150°C

Data taken at VDD=3.3V, continuous transmission at 1Mbit/s, single transmitter enabled.

HI-1573, HI-1574

ORDERING INFORMATION

HI - 157x xx x x (Plastic)

PART NUMBER	LEAD FINISH
Blank	Tin / Lead (Sn / Pb) Solder
F	100% Matte Tin (Pb-free, RoHS compliant)

PART NUMBER	TEMPERATURE RANGE	FLOW	BURN IN
I	-40°C TO +85°C	I	NO
T	-55°C TO +125°C	T	NO
M	-55°C TO +125°C	M	YES

PART NUMBER	PACKAGE DESCRIPTION
PC	44 PIN PLASTIC CHIP-SCALE (LPCC)
PS	20 PIN PLASTIC ESOIC (Wide Body, Thermally Enhanced SOIC w/Heat Sink)

PART NUMBER	RXENA = 0		RXENB = 0	
	RXA	RXA	RXB	RXB
1573	0	0	0	0
1574	1	1	1	1

HI - 157xCD x (Ceramic)

PART NUMBER	TEMPERATURE RANGE	FLOW	BURN IN	LEAD FINISH
I	-40°C TO +85°C	I	NO	Gold (Pb-free, RoHS compliant)
T	-55°C TO +125°C	T	NO	Gold (Pb-free, RoHS compliant)
M	-55°C TO +125°C	M	YES	Tin / Lead (Sn / Pb) Solder

PART NUMBER	RXENA = 0		RXENB = 0		PACKAGE DESCRIPTION
	RXA	RXA	RXB	RXB	
1573CD	0	0	0	0	20 PIN CERAMIC SIDE BRAZED DIP
1574CD	1	1	1	1	20 PIN CERAMIC SIDE BRAZED DIP

RECOMMENDED TRANSFORMERS

The HI-1573 and HI-1574 transceivers have been characterized for compliance with the electrical requirements of MIL-STD-1553 when used with the following

transformers. Holt recommends the Premier Magnetics parts as offering the best combination of electrical performance, low cost and small footprint.

MANUFACTURER	PART NUMBER	APPLICATION	TURNS RATIO(S)	DIMENSIONS
Technotrol	TL1553-45	Isolation	Dual tapped 1:1.79, 1:2.5	.630 x .630 x .155 inches
Premier Magnetics	PM-DB2725EX	Isolation	Dual tapped 1:1.79, 1:2.5	.500 x .500 x .375 inches
Technotrol	TQ1553-2	Stub coupling	1:1.4	.625 x .625 x .250 inches
Premier Magnetics	PM-DB2702	Stub coupling	1:1.4	.625 x .500 x .250 inches

20-PIN PLASTIC SMALL OUTLINE (ESQIC) - WB
(Wide Body, Thermally Enhanced)

Package Type: 24HEW

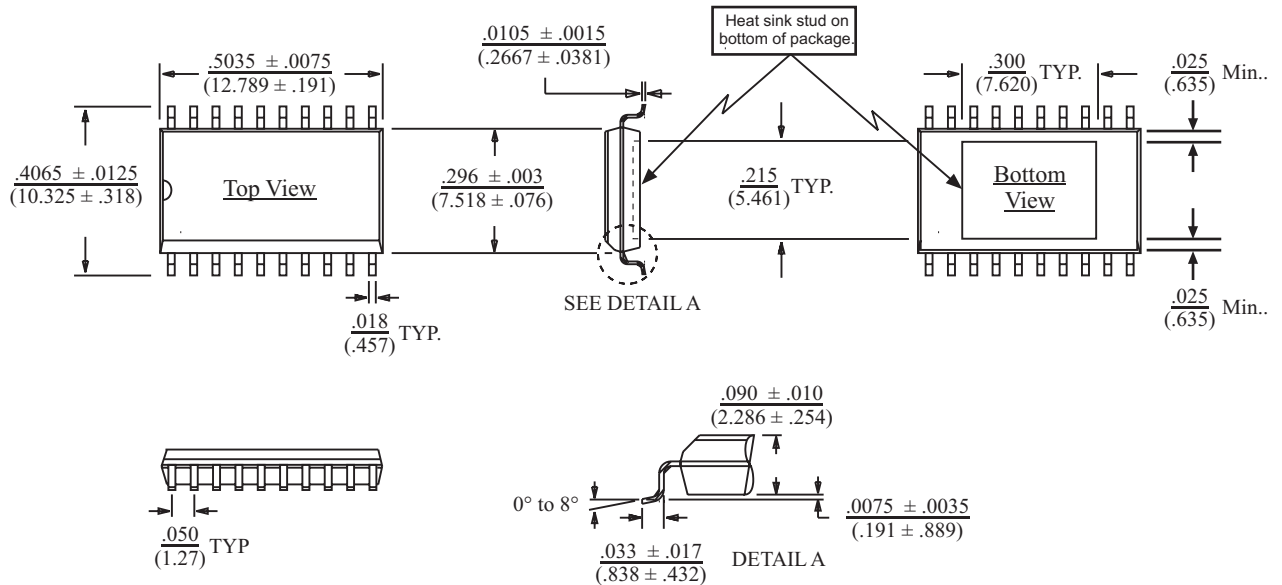

20-PIN CERAMIC SIDE-BRAZED DIP

PACKAGE TYPE: 20C

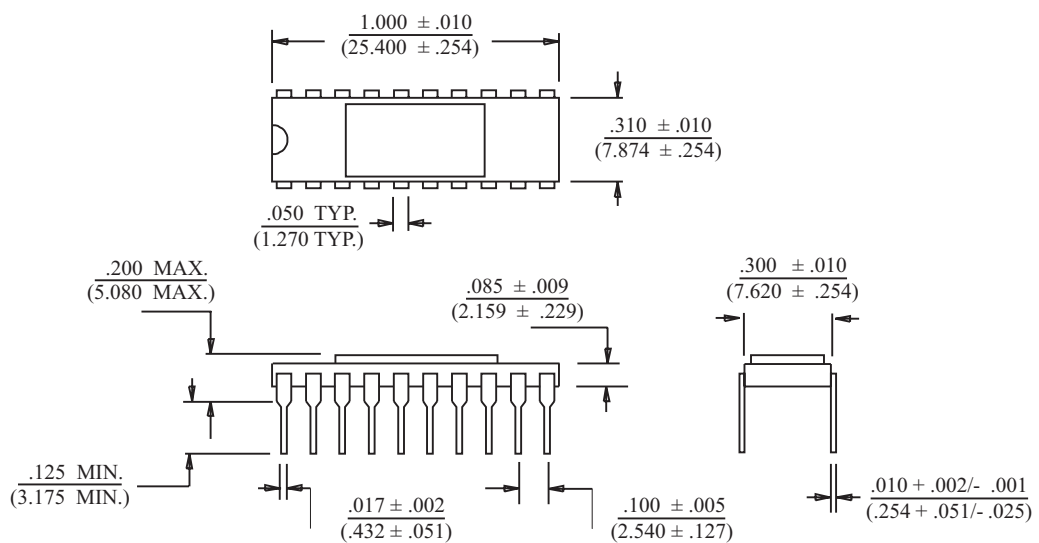

44-PIN PLASTIC CHIP-SCALE PACKAGE

