

# GSD

M39012/20-0504

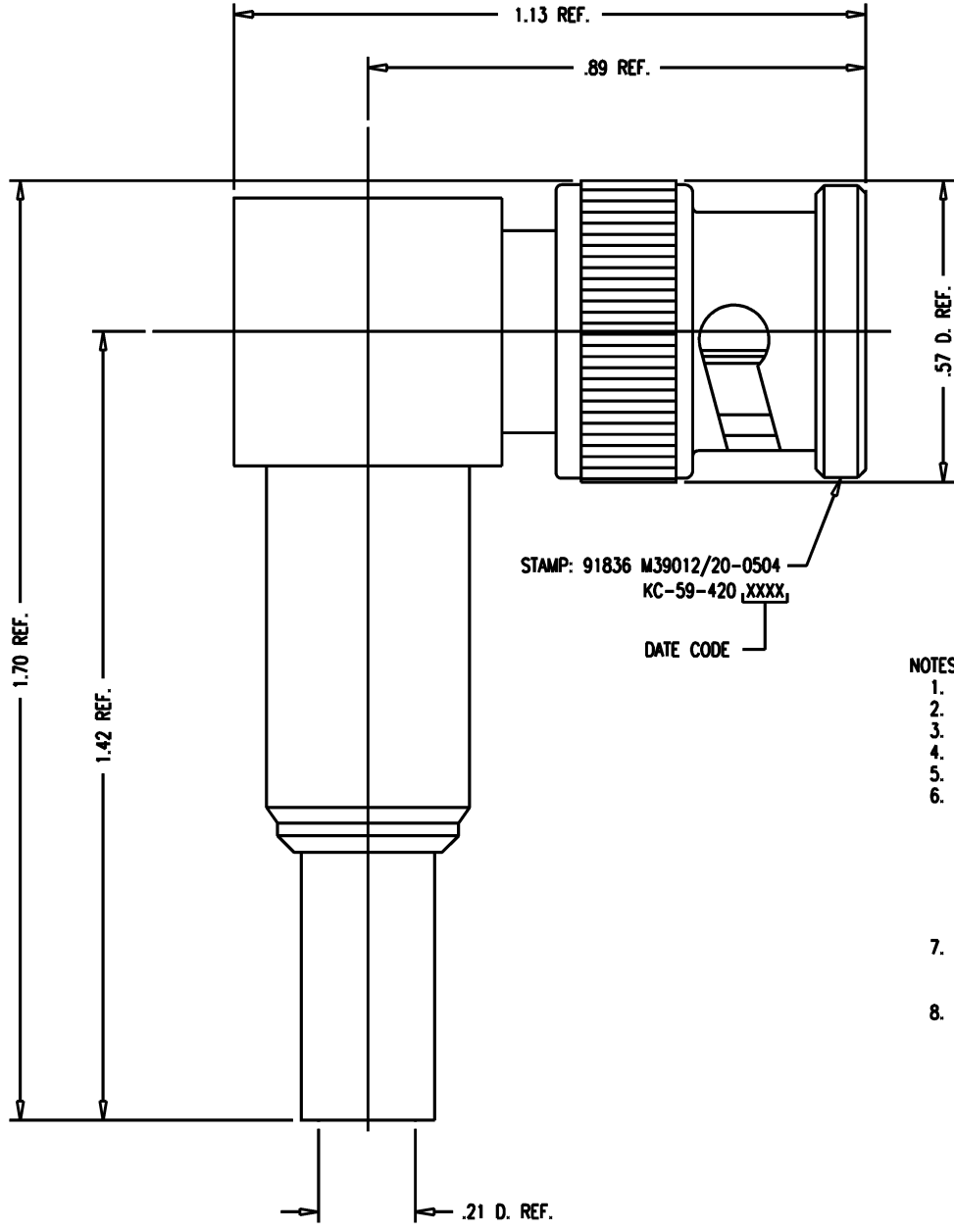

STAMP: 91836 M39012/20-0504  
 KC-59-420,XXXX  
 DATE CODE

- NOTES:
1. FOR USE WITH RG-58, 141 & 303/U CABLE.
  2. FOR CABLING INSTRUCTIONS SEE CP-465.
  3. FOR CABLE TRIMMING USE KTJ-123 & KTD-166.
  4. FOR CRIMPING USE DIE KTH-2001.
  5. INTERFACE PER MIL-STD-348, 301-1.
  6. MATERIALS:  
 INSULATORS: TEFLON, ASTM-D-1457  
 GASKET: SILICONE RUBBER, ZZ-R-765  
 K-GRIP SLEEVE: COM BRONZE, ALLOY 220  
 OUTER CONTACT } BER. COPPER, ASTM-B-196  
 BNC C/C CONTACT F }  
 ALL OTHER METAL PARTS: BRASS, ASTM-B16
  7. FINISHES:  
 CENTER CONTACTS: HARD GOLD PLATE, PER MIL-G-45204  
 ALL OTHER METAL PARTS: SILVER PLATE, QQ-S-365
  8. ELECTRICAL CHARACTERISTICS:  
 NOMINAL IMPEDANCE: 50 OHMS  
 WORKING VOLTAGE: 500 VRMS  
 FREQUENCY RANGE: DC TO 4 GHz

REVISIONS

ISSUE	CHANGES
9	CN 34481 C REDRAWN KH 04/22/93
10	CN 35064 C JCA 11/22/93
11	CN 39781 C PMC 2/5/07

KAM2728

SCALE 4:1

APPROX SURFACE AREA

KC-59-420

USED ON

REF:

PLUG, ANGLE, BNC

DRAWN KH DATE 04/22/93

DESIGN MJB DATE 04/23/93

APPR. DATE

**KINGS**  
 ELECTRONICS CO., INC.  
 ROCK HILL, SOUTH CAROLINA 29730

M39012/20-0504

# GSD