

Model 2805

110 Channel CATV Private Network Solution (PNS)



Features

- Transmits up to 110 Channels Over One Singlemode Fiber at 1310 nm.
- VSB/AM Transmission Ensures Compatibility with Standard CATV Modulators, Processors, etc.
- The Transmitter Includes Status Indicator LED's that Provide Easy Assessment of the Transmitter's Performance.
- Excellent for Structured In-Building Premise Wiring Video Distribution. .
- High Capacity Backbone Transport for Multiple Data Services (RS-232, T1/E1, Ethernet, etc.) Via CATV RF Modem.
- CATV HFC Distribution Network, Distance Learning, CCTV Video Surveillance, Campus Video Distribution, Teleconferencing and more.
- +13 dBm Optical Output Power Supports Links to beyond 20 km.

The Model 2805 110 Channel CATV PNS transmitter is part of a robust system for transporting up to 110 Channels of VSB/AM modulated signals over a singlemode optical fiber. The system provides 40-870 MHz of usable bandwidth for video signals stacked at 6 MHz intervals. A low loss singlemode fiber allows full channel loading to beyond 20 km while maintaining a good carrier-to-noise ratio. The Model 2805 may be used with the Model 2807 mini-node receiver for use in return path and multiple splitter applications or with the Model 2808 receiver for basic 110 channel CATV transmission. In all cases, the link provides excellent performance for many demanding applications such as broadband LANs, distance learning, and multiple data services.

110 Channel Transmitter Part Numbers

Description	Part Number (SC/APC Optical Connector)	Part Number (FC/APC Optical Connector)
1RU Transmitter, +6 dBm Optical Output Power	2805TD-SCSP/06	2805TD-SCAP/06
1RU Transmitter, +8 dBm Optical Output Power	2805TD-SCSP/08	2805TD-SCAP/08
1RU Transmitter, +10 dBm Optical Output Power	2805TE-SCSP/10	2805TE-SCAP/10
1RU Transmitter, +12 dBm Optical Output Power	2805TF-SCSP/12	2805TF-SCAP/12
1RU Transmitter, +13 dBm Optical Output Power	2805TG-SCSP/13	2805TG-SCAP/13

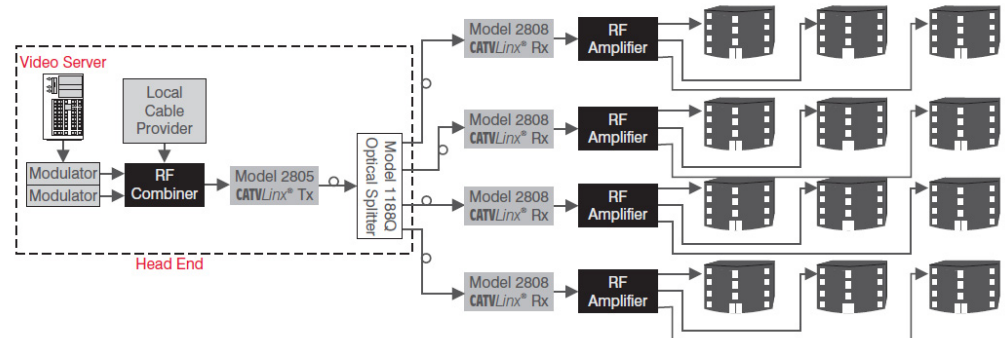

RF and Optical Characteristics

Parameter	Min	Typ	Max	Units
Channel Loading	-	-	110	ch.
Operating Wavelength	1290	1310	1330	nm
Bandwidth	40	-	870	MHz
Input/Output RF Impedance	-	75	-	Ohms
Side Mode Suppression Ratio	30	-	-	dB
Backreflection Tolerance	-	-	-50	dB
Required Fiber Bandwidth	2,000	-	-	MHz
Composite Second Order (CSO)	-	-60	-	dBc
Composite Triple Beat (CTB)	-	-65	-	dBc
Carrier-to-Noise Ratio		See Graph		dB

System performance specifications indicated for use with 9/125 μ m singlemode fiber.

Carrier-to-Noise Performance

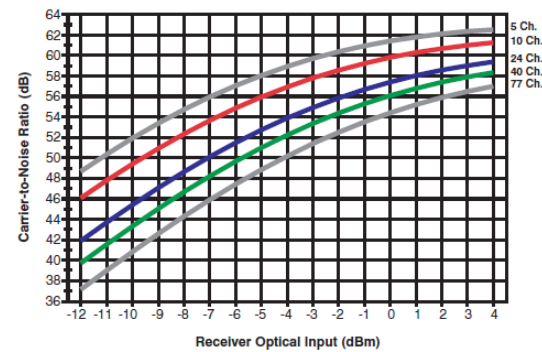

Electrical Characteristics

Parameter	Min	Typ	Max	Units
Power Supply Voltage	-	120	240	V _{AC}
Power Supply Frequency	50	60	-	Hz
Power Dissipation	-	20	-	Watts
Fuse Rating (Slow Blow)		1.25		A

Physical Characteristics

Parameter	Min	Typ	Max	Units
Weight	-	5.5	-	lbs
		2.5		kg
Dimensions	-	19 x 1.72 x 12.1	-	in
		483 x 43.7 x 307		mm

Environmental Characteristics

Parameter	Min	Typ	Max	Units
Operating Temperature Range	0	-	+45	°C
Storage Temperature Range	-20	-	+70	°C
Relative Humidity	0	-	90	%