

GSD

M39012/55-4502

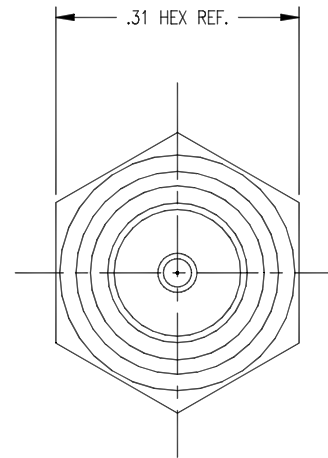
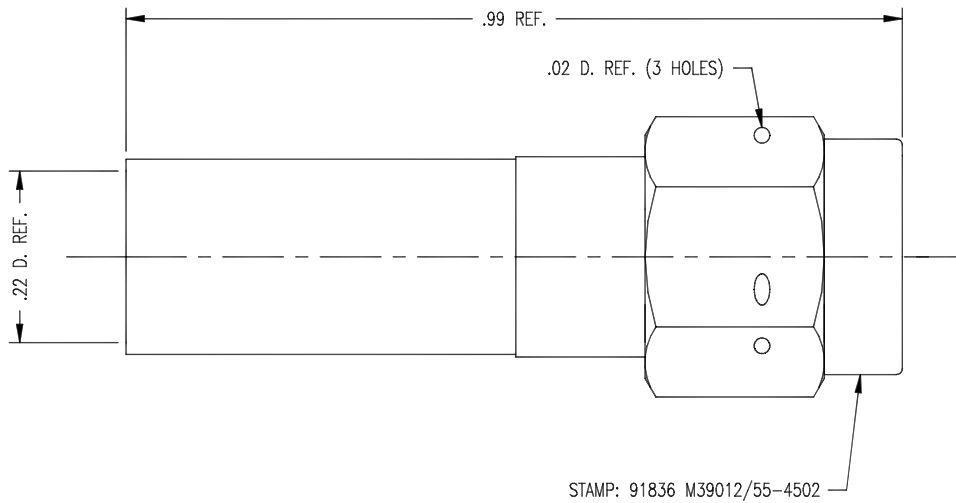

REVISIONS

ISSUE	CHANGES
4	CN 33974 D REDRAWN JCA 08/27/92
5	CN 34221 D JCA 01/21/93
6	CN 35539 C KH 05/23/94
H	CN ER10692 PSM 10/10/08

NOTES:

- FOR USE WITH M17/60-RG142 AND M17/128-RG400 CABLES.
- FOR CABLING INSTRUCTIONS SEE CP-493.
- FOR TRIMMING USE KTJ-169 AND KTD-215.
- FOR CRIMPING USE DIE KTH-2113.
- INTERFACE PER MIL-STD-348, FIG. 310-1.
- MARK PACKAGE: KINGS 875-21-18 XXXX (DATE CODE)
- MATERIALS:
 - INSULATOR-TEFLON, ASTM-D-1457
 - GASKET-SILICONE RUBBER, ZZ-R-765
 - K-GRIP SLEEVE-COMMERCIAL BRONZE, ALLOY 220
 - CENTER CONTACT-BRASS, ASTM-B16
 - ALL OTHER METAL PARTS-BER. COP., ASTM-B-196
- FINISHES:
 - ALL METAL PARTS-HARD GOLD PLATE PER MIL-G-45204
- ELECTRICAL CHARACTERISTICS:
 - NOMINAL IMPEDANCE-50 OHMS
 - FREQUENCY RANGE-DC TO 12.4 GHz

JCA3057

SCALE 6:1	
APPROX SURFACE AREA	
M39012/55-4502	
USED ON	
REF:	
PLUG, SMA	
DRAWN JCA	DATE 08/28/92
DESIGN LI	DATE 08/28/92
APPR.	DATE
	
Winchester Electronics 62 Barnes Industrial Road North Wallingford, CT 06492	
875-21-18	

GSD

B
SIZE