

## FEATURES

- Max. toggle frequency of 700MHz
- Clock to Q max. of 1200ps
- IEE min. of -98mA
- Industry standard 100K ECL levels
- Extended supply voltage option:  
VEE = -4.2V to -5.5V
- Voltage and temperature compensation for improved noise immunity
- Internal 75kΩ input pull-down resistors
- 50% faster than Fairchild 300K
- Better than 20% lower power than Fairchild
- Function and pinout compatible with Fairchild F100K
- Available in 28-pin PLCC package

## DESCRIPTION

The SY100S351 offers six D-type, edge-triggered, master/slave flip-flops with differential outputs, and is designed for use in high-performance ECL systems. The flip-flops are controlled by the signal from the logical OR operation on a pair of common clock signals (CP<sub>a</sub>, CP<sub>b</sub>). Data enters the master when both CP<sub>a</sub> and CP<sub>b</sub> are LOW and transfers to the slave when either CP<sub>a</sub> or CP<sub>b</sub> (or both) go to a logic HIGH. The Master Reset (MR) input overrides all other inputs and takes the Q outputs to a logic LOW. The inputs on this device have 75kΩ pull-down resistors.

## PIN NAMES

Pin	Function
D <sub>0</sub> — D <sub>5</sub>	Data Inputs
CP <sub>a</sub> , CP <sub>b</sub>	Common Clock Inputs
MR	Asynchronous Master Reset Input
Q <sub>0</sub> — Q <sub>5</sub>	Data Outputs
$\bar{Q}_0$ — $\bar{Q}_5$	Complementary Data Outputs
VEES	VEE Substrate
VCCA	VCCO for ECL Outputs

## BLOCK DIAGRAM

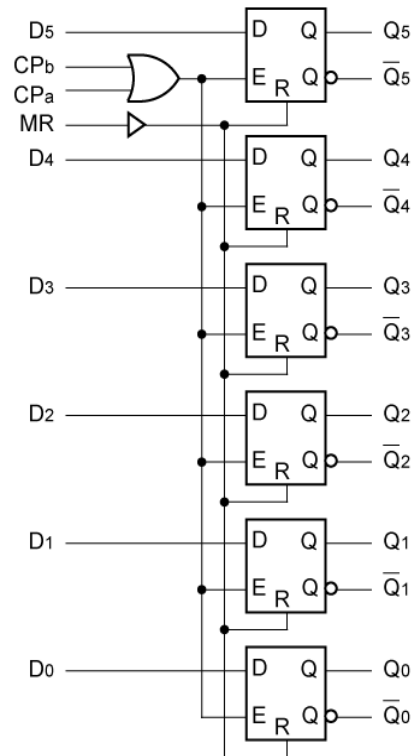

**PACKAGE/ORDERING INFORMATION**

**Ordering Information**

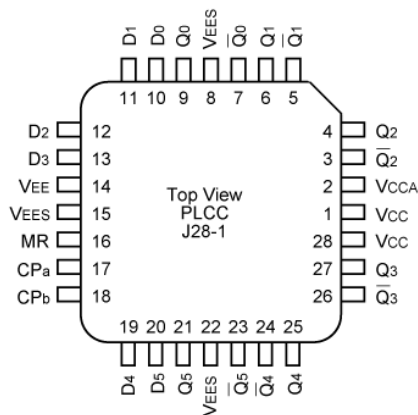

**28-Pin PLCC (J28-1)**

Part Number	Package Type	Operating Range	Package Marking	Lead Finish
SY100S351JC	J28-1	Commercial	SY100S351JC	Sn-Pb
SY100S351JCTR <sup>(1)</sup>	J28-1	Commercial	SY100S351JC	Sn-Pb
SY100S351JZ <sup>(2)</sup>	J28-1	Commercial	SY100S351JZ with Pb-Free bar-line indicator	Matte-Sn
SY100S351JZTR <sup>(1,2)</sup>	J28-1	Commercial	SY100S351JZ with Pb-Free bar-line indicator	Matte-Sn
SY100S351JY <sup>(1)</sup>	J28-1	Industrial	SY100S351JY with Pb-Free bar-line indicator	Matte-Sn
SY100S351JYTR <sup>(1,2)</sup>	J28-1	Industrial	SY100S351JY with Pb-Free bar-line indicator	Matte-Sn

**Notes:**

1. Tape and Reel.
2. Pb-Free package is recommended for new designs.

**TRUTH TABLES**

Asynchronous Operation <sup>(1)</sup>				
Inputs				Outputs
D <sub>n</sub>	CP <sub>a</sub>	CP <sub>b</sub>	MR	Q <sub>n</sub> (t+1)
X	X	X	H	L

**NOTE:**

1. H = High Voltage Level  
L = Low Voltage Level  
X = Don't Care  
t = Time before CP Positive Transition  
t+1 = Time after CP Positive Transition  
u = LOW-to-HIGH Transition

Synchronous Operation <sup>(1)</sup>				
Inputs				Outputs
D <sub>n</sub>	CP <sub>a</sub>	CP <sub>b</sub>	MR	Q <sub>n</sub> (t+1)
L	u	L	L	L
H	u	L	L	H
L	L	u	L	L
H	L	u	L	H
X	H	u	L	Q <sub>n</sub> (t)
X	u	H	L	Q <sub>n</sub> (t)
X	L	L	L	Q <sub>n</sub> (t)

**DC ELECTRICAL CHARACTERISTICS**

$V_{EE} = -4.2V$  to  $-5.5V$  unless otherwise specified;  $V_{CC} = V_{CCA} = GND$

Symbol	Parameter	Min.	Typ.	Max.	Unit	Condition
$I_{IH}$	Input HIGH Current				$\mu A$	$V_{IN} = V_{IH} (Max.)$
	MR	—	—	270		
	D <sub>0</sub> – D <sub>5</sub>	—	—	200		
	CP <sub>a</sub> , CP <sub>b</sub>	—	—	300		
$I_{EE}$	Power Supply Current	-98	-71	-49	mA	Inputs Open

**AC ELECTRICAL CHARACTERISTICS**

$V_{EE} = -4.2V$  to  $-5.5V$  unless otherwise specified;  $V_{CC} = V_{CCA} = GND$

Symbol	Parameter	$T_A = -40^{\circ}C$		$T_A = 0^{\circ}C$		$T_A = +25^{\circ}C$		$T_A = +85^{\circ}C$		Unit	Condition
		Min.	Max.	Min.	Max.	Min.	Max.	Min.	Max.		
$f_{MAX}$	Toggle Frequency	700	—	700	—	700	—	700	—	MHz	
$t_{PLH}$ $t_{PHL}$	Propagation Delay CP <sub>a</sub> , CP <sub>b</sub> to Output	—	1200	—	1200	—	1200	—	1200	ps	
$t_{PLH}$ $t_{PHL}$	Propagation Delay MR to Output	—	1200	—	1200	—	1200	—	1200	ps	
$t_{TLH}$ $t_{THL}$	Transition Time 20% to 80%, 80% to 20%	300	900	300	900	300	900	300	900	ps	
$t_s$	Set-up Time D <sub>0</sub> –D <sub>5</sub> MR (Release Time)	500 1000	— —	500 1000	— —	500 1000	— —	500 1000	— —	ps	
$t_H$	Hold Time, D <sub>0</sub> –D <sub>5</sub>	550	—	550	—	550	—	550	—	ps	
$t_{PW} (H)$	Pulse Width HIGH CP <sub>a</sub> , CP <sub>b</sub> , MR	1000	—	1000	—	1000	—	1000	—	ps	

**TIMING DIAGRAMS**

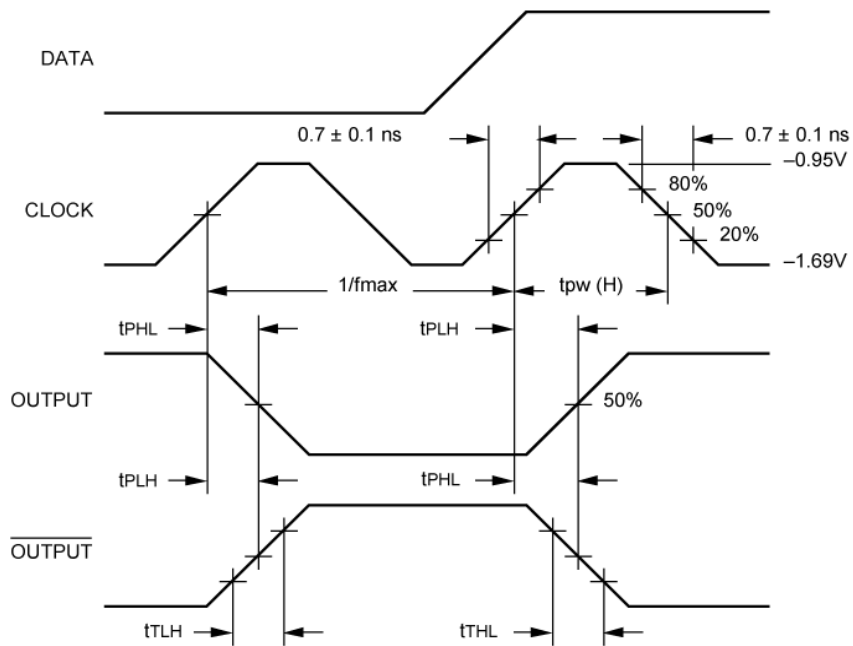

**Propagation Delay (Clock) and Transition Times**

**NOTE:**

VEE = -4.2V to -5.5V unless otherwise specified; VCC = VCCA = GND

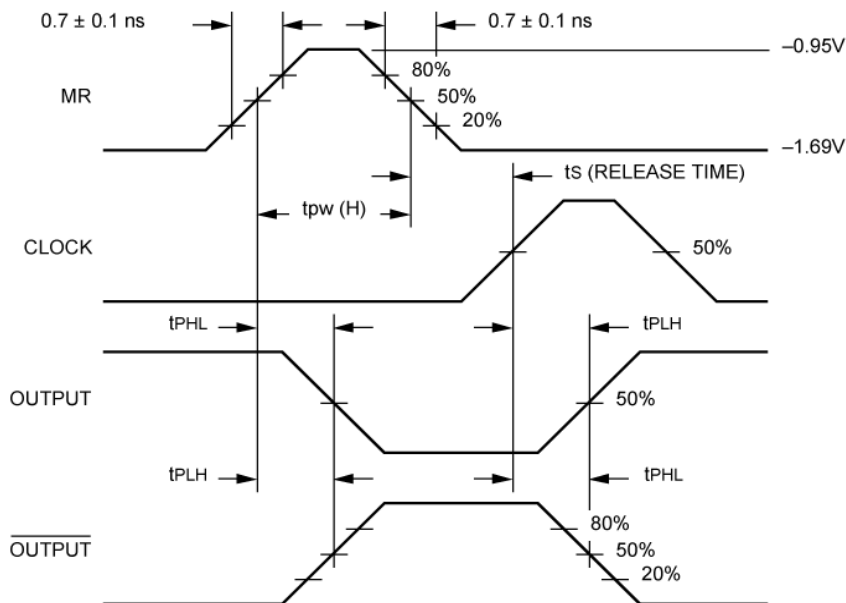

**Propagation Delay (Resets)**

## TIMING DIAGRAMS

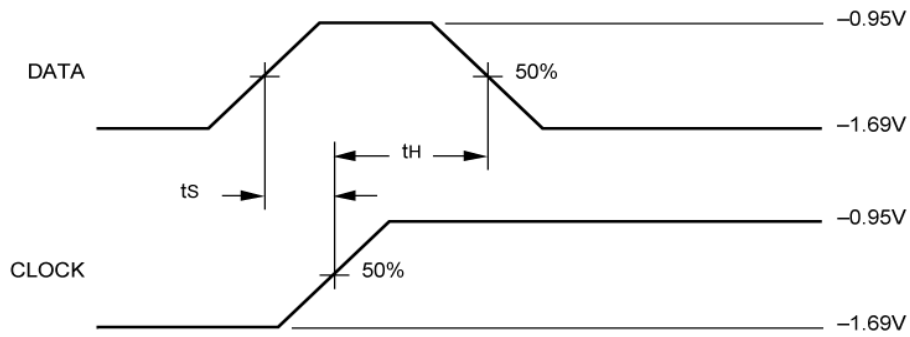

**Data Set-up and Hold Time**

**Notes:**

1.  $V_{EE} = -4.2V$  to  $-5.5V$  unless otherwise specified;  $V_{CC} = V_{CCA} = GND$
2.  $t_s$  is the minimum time before the transition of the clock that information must be present at the data input.
3.  $t_H$  is the minimum time after the transition of the clock that information must remain unchanged at the data input.

**28-PIN PLCC (J28-1)**

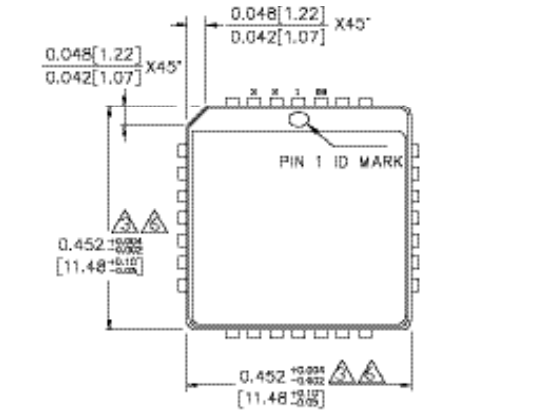

TOP VIEW

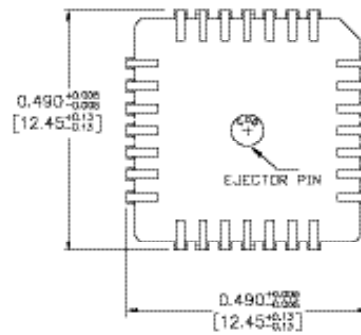

BOTTOM VIEW

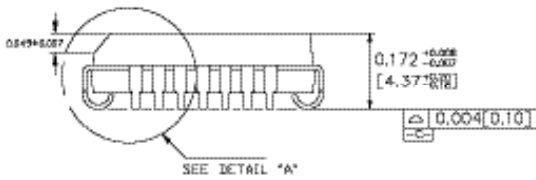

SIDE VIEW

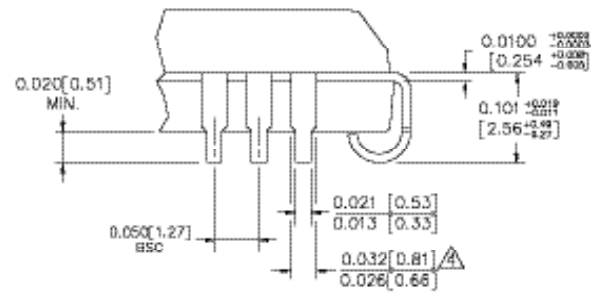

DETAIL "A"

NOTES:

1. DIMENSIONS ARE IN INCHES [MM].
2. CONTROLLING DIMENSION: INCHES.
3. DIMENSION DOES NOT INCLUDE MOLD FLASH OR PROTRUSIONS, EITHER OF WHICH SHALL NOT EXCEED 0.008 [0.203].
4. LEAD DIMENSION DOES NOT INCLUDE DAMBAR PROTRUSION.
5. MAXIMUM AND MINIMUM SPECIFICATIONS ARE INDICATED AS FOLLOWS: MAX/MIN.
6. PACKAGE TOP DIMENSION MAY BE SLIGHTLY SMALLER THAN BOTTOM DIMENSION.

Rev. A

**MICREL, INC. 2180 FORTUNE DRIVE SAN JOSE, CA 95131 USA**

TEL + 1 (408) 944-0800 FAX + 1 (408) 474-1000 WEB <http://www.micrel.com>

The information furnished by Micrel in this datasheet is believed to be accurate and reliable. However, no responsibility is assumed by Micrel for its use. Micrel reserves the right to change circuitry and specifications at any time without notification to the customer.

Micrel Products are not designed or authorized for use as components in life support appliances, devices or systems where malfunction of a product can reasonably be expected to result in personal injury. Life support devices or systems are devices or systems that (a) are intended for surgical implant into the body or (b) support or sustain life, and whose failure to perform can be reasonably expected to result in a significant injury to the user. A Purchaser's use or sale of Micrel Products for use in life support appliances, devices or systems is at Purchaser's own risk and Purchaser agrees to fully indemnify Micrel for any damages resulting from such use or sale.

© 2006 Micrel, Incorporated.