

MX•COM, INC. MiXed Signal ICs

DATA BULLETIN

MX102

Autocorrelating Signal Processor

Features

- Low Signal Level Input of 10mVrms
- Wide Signal Frequency Range from 17Hz to 13kHz
- On-Chip Gain Amplifier
- Digital Output Signal ($f_{IN} \times 4$)
- Divided-Down Clock Output
- Low Supply Voltage Operation of 2.5 V
- Low Current Drain

Applications

- Medical Instruments
- Sonar Detection
- Remote Signaling
- Pagers
- Mobile Radio
- Slow Data Rate Communication
- Tone Detection

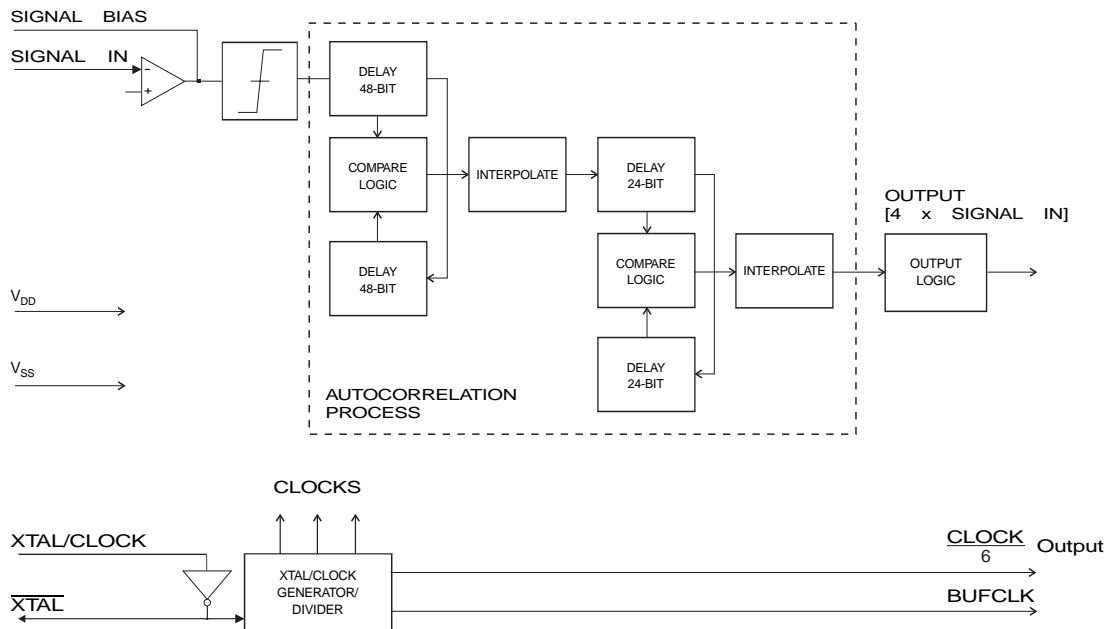

The MX102 is a single-chip device to extract single periodic signals from very high random-noise environments.

Using patented autocorrelation techniques the MX102 will enhance the input signal's signal-to-noise ratio by as much as 8.5dB and provide a digital output signal centered at four times (x4) the input frequency.

The amplitude of non-periodic components of the signal is substantially reduced. The patented autocorrelator compares the incoming signal to itself; the more elements of the waveform that are seen as periodic, the higher the energy at the microcircuit output.

The MX102 cascades two autocorrelators, each one improving the signal-to-noise ratio

With a random noise input the output will swing rail-to-rail at random (peak-limited). The input/output signal delay is fixed by the choice of clock frequency and the length of the internal register. The MX102 will operate at supply voltages of between 2.5 volts and 5.5 volts and with Xtal/clock frequencies from 20kHz to 2.5MHz. Using various Xtal/clock inputs the device can be set to accept input signal frequencies, in bands, from 17.0Hz to 13.0kHz.

Two uncommitted clock outputs are available: one to supply a 'divided-down' Xtal/clock frequencies and the second is a buffered output for use in external and peripheral functions.

This MX102 is available in the following package styles: 16-pin SOIC (MX102DW) and 16-pin CDIP (MX102J).

CONTENTS

Section	Page
1. Block Diagram	3
2. Signal List	4
3. External Components	5
4. General Description	6
4.1 Signal	6
4.2 Input Frequency Range.....	6
5. Performance Specification	8
5.1 Electrical Performance	8
5.2 Packaging	10

MX•COM, Inc. reserves the right to change specifications at any time and without notice.

1. Block Diagram

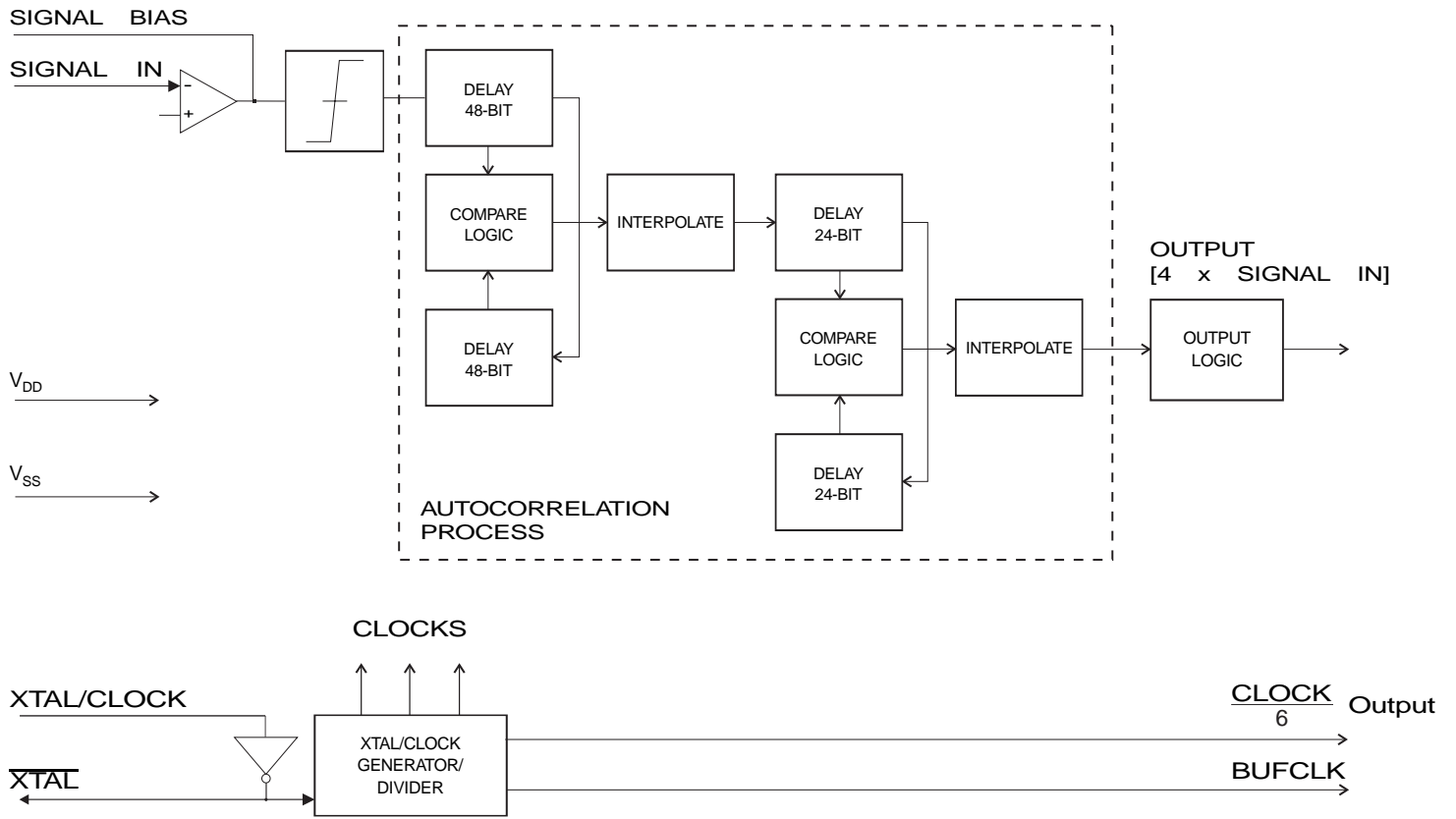

Figure 1: Device Block Diagram

2. Signal List

Packages	Signal		Description	
	DW/J	Name		Type
1		Signal In	input	The inverting input to the analog amplifier/comparator. Used with the Signal Bias pin; external coupling components are required. See Figure 2
3		Signal Bias	output	The output of the analogue amplifier/comparator. Do not load this pin with peripheral circuitry; there is no drive capacity for off-chip signaling. The feedback resistor should be not less than 200kΩ. See Figure 2.
4		V _{DD}	power	Positive supply rail. A single, stable power supply is required. Note that this device has two V _{DD} pins; this input is positioned to prevent cross-talk, either or both may be connected to the host circuit's supply line. Do not attempt to draw current from either V _{DD} pin.
5		BUFCLK	output	Buffered inverter oscillator digital output. May be used as test point to align clock frequency or to drive other circuitry.
6		$\overline{\text{XTAL}}$	output	The output of the on-chip clock oscillator inverter.
8		Xtal/Clock	input	The input to the on-chip clock oscillator inverter; this may be a Xtal, resonator or clock pulse input. The selection of this frequency will affect the operational input signal bandwidth (and output frequency) of this device; refer to Table 4. Note that the choice of V _{DD} will determine the maximum Xtal/clock frequency and hence the maximum useable signal input frequency. Operation of this microcircuit without an active Xtal or clock input may cause device damage. A clock pulse input is fed directly into this pin; Xtal/clock components are not required. See Table 2.
9		V _{SS}	power	Negative Supply
11		CLK ÷ 6	output	A squarewave output clock signal at the rate of Clock/6; provided for peripheral and test purposes.
13		OUTPUT	output	(f _{OUT} = 4 x f _{SIGNAL IN}). The auto-correlated output signal at four times (x 4) the input signal (see Figure 3). There is a time delay between input and output signals (see Specifications).
16		V _{DD}	power	Positive supply rail. A single, stable power supply is required. Note that this device has two V _{DD} pins; either or both may be connected to the host circuit's supply line. Do not attempt to draw current from either V _{DD} pin. The choice of V _{DD} will determine the maximum Xtal/clock frequency and hence the maximum useable signal input frequency (see Figure 4).
2, 7, 10, 12, 14, 15			N/C	No internal connection. Leave open circuit

Table 1: Signal List

V _{DD} (V)	Max. Xtal/Clock Freq. (MHz)
2.5	0.625
3.0	1.0
5.0	2.5

Table 2: Maximum Usable Xtal/Clock Frequencies

3. External Components

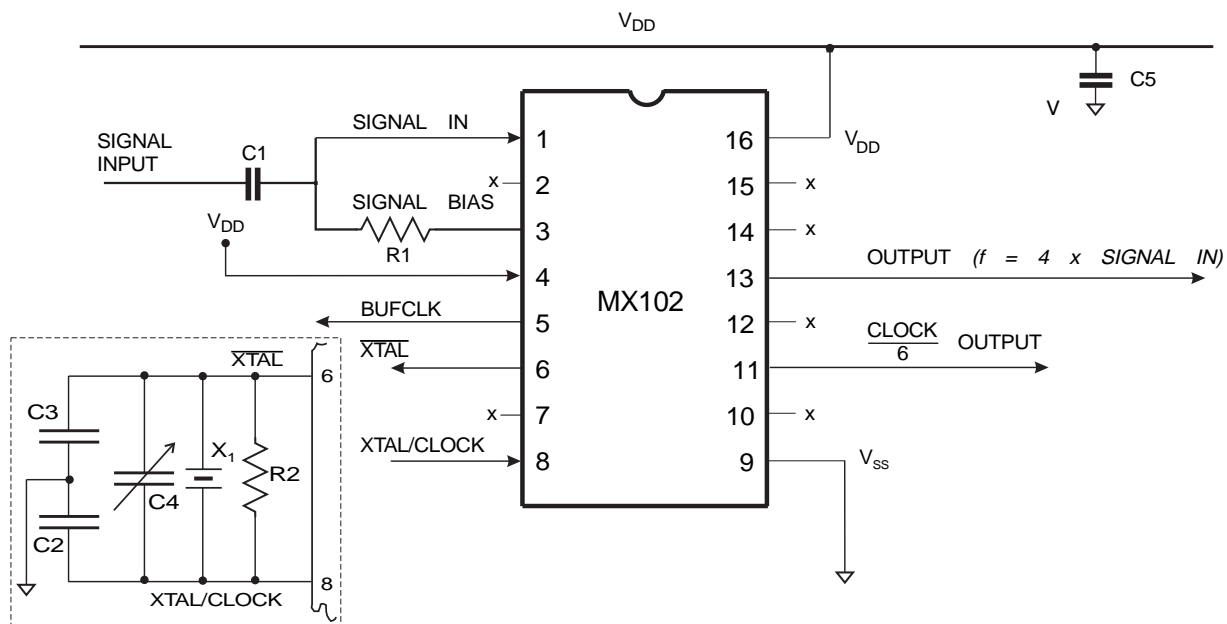

Figure 2: Recommended External Components

R1		2.2MΩ
R2		1.0MΩ
C1		0.01μF
C2	Note 1	47.0pF -see below
C3	Note 1	47.0pF -see below
C4	Note 2	5 - 65pF -see below
C5		1.0μF
X1		560kHz resonator
X1 range		20kHz to 2.5MHz

Table 3: Recommended External Components

Recommended External Component Notes:

1. Values of capacitors C2 and C3 should be reduced for higher Xtal frequencies and/or lower supply voltages (V_{DD}).
2. C4 is suggested for frequency setting when using a resonator; when a Xtal is used C4 is omitted.

4. General Description

4.1 Signal

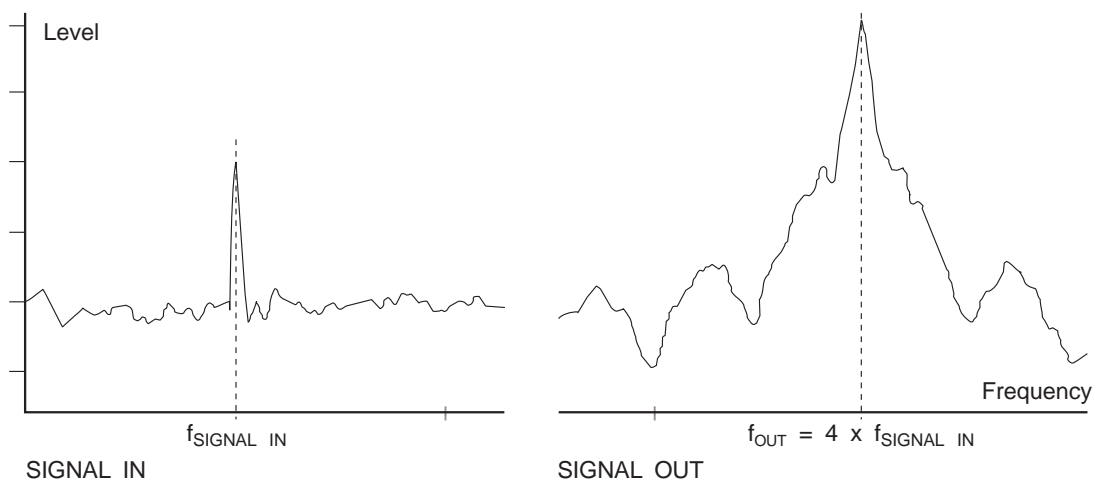

Figure 3: MX102 Input/Output Relationships

Note:

1. The frequency of the output signal is four times (x4) that of the input signal.

4.2 Input Frequency Range

The MX102 has a wide frequency range, but care must be taken to choose the Xtal frequency appropriate for your application.

Xtal/Clock Frequency (kHz)	Input Freq. (Hz)		BW (Hz)
	Min.	Max.	
20	17	105	88
100	88	526	443
200	166	1052	886
300	250	1579	1329
400	333	2105	1772
500	416	2632	2216
560	467	2947	2480
600	500	3158	2658
700	583	3684	3101
800	667	4210	3543
900	750	4737	3987
1000	833	5263	4430
2000	1667	10526	8859
2500	2083	13157	11074

Table 4: Input Signal Ranges vs Xtal/Clock Frequency

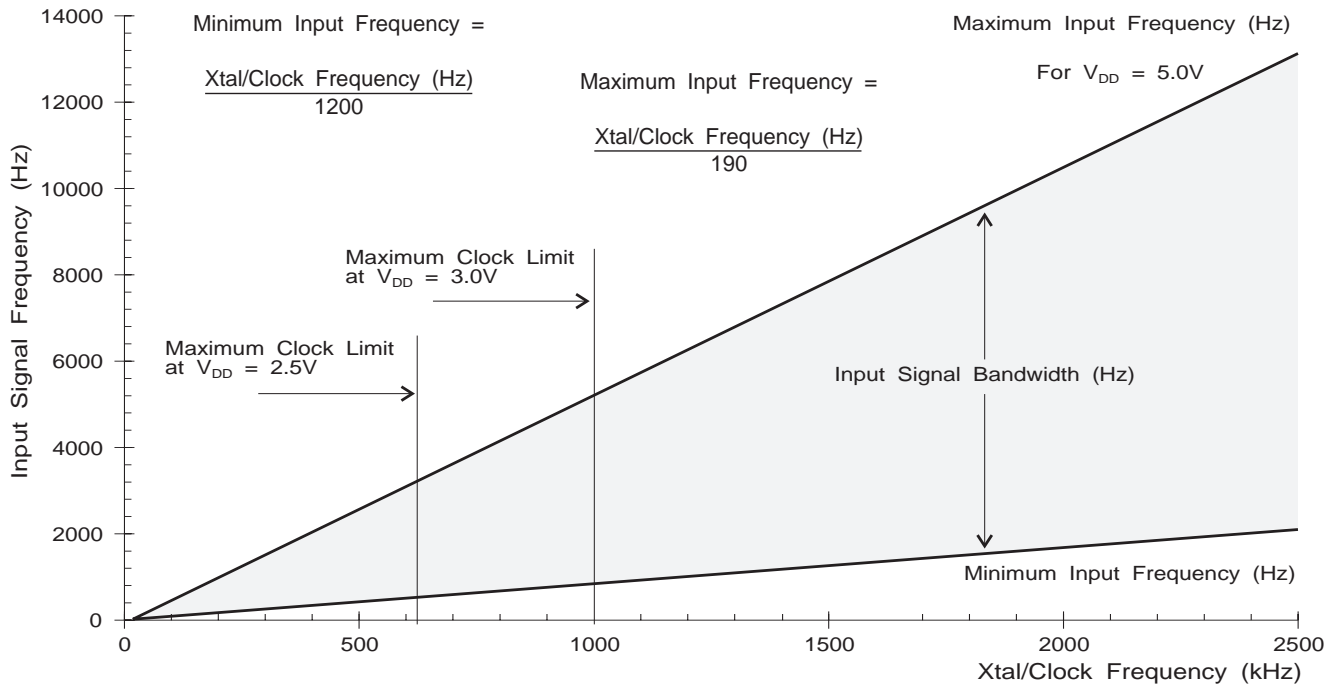

Figure 4: Input Signal Ranges vs Xtal/Clock Frequency

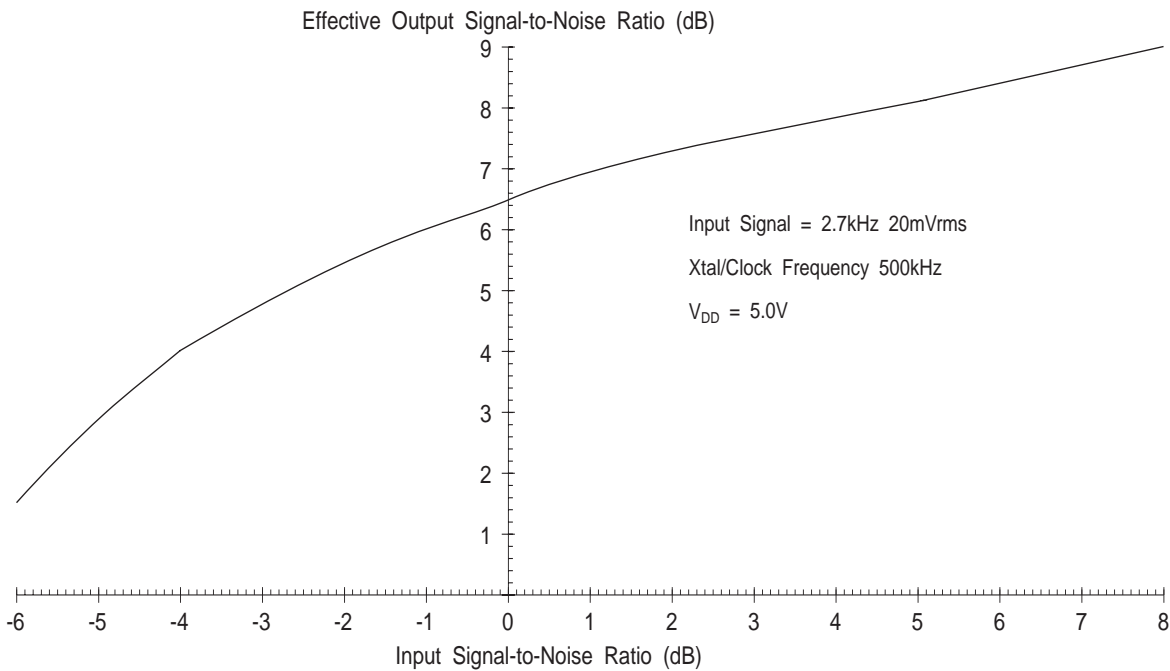

Figure 5: Enhancement of Signal-To-Noise Ratio

Note:

1. The graph shown in Figure 5 illustrates the signal-to-noise enhancement that can be obtained, under varying input conditions, from the MX102.

5. Performance Specification

5.1 Electrical Performance

Absolute Maximum Ratings

Exceeding these maximum ratings can result in damage to the device.

General	Min.	Max.	Units
Supply Voltage	-0.3	7.0 volts	V
Input Voltage at any pin	-0.3	($V_{DD}+0.3$ volts)	V
Current			
V_{DD}	-30	30	mA
V_{SS}	-30	30	mA
Any other pins	-20	20	mA
Maximum Device Dissipation	100		mW
Operating Temperature	-40°	85	°C
Storage Temperature	-40°	125	°C

Operating Limits

Correct operation of the device outside these limits is not implied.

	Min.	Typ.	Max.	Units
V_{DD}	2.5	3.3/5.0	5.5	V
Xtal/Clock	20		2500	kHz
Operating Temperature	-40		85	°C

Operating Characteristics

For the following conditions unless otherwise specified:

$V_{DD} = 5.0V$, $T_{AMB} = 25^{\circ}C$

Xtal/Clock = 560kHz, Input Test Signal = 200mV_{RMS}

	Notes	Min.	Typ.	Max	Units
Static Values					
Supply Current		-	1.0	2.5	mA
	2	-	4.0	-	mA
Logic '1' Level		80%	-	-	V
Logic '0' Level		-	-	20%	V
Digital Output Impedance		-	4.0	10.0	k Ω
Dynamic Values					
Signal Input	3	20.0	-	1000	mV _{RMS}
Analog (Input) Amplifier Gain	4	20.0	-	-	dB
	5	9.0	-	-	dB
	6	10.0	-	-	dB
Recommended Input Signal Duty Cycle Ratio		35	50	-	%
Frequency Out/Frequency In Ratio		4.0	-	4.0	%
Maximum Xtal/Clock Frequency	1	2.5	-	-	MHz
Minimum Xtal/Clock Frequency				20.0	kHz
Frequency Input Range					
Xtal/Clock = 560kHz	7	500	-	3000	Hz
Table 4		1/1200		1/190	Xtal/Clock
Input to Output Delay	8	-	1.4		ms
Output resolution		-	1/6	-	Xtal/Clock

Operating Characteristics Notes:

1. Maximum Xtal/clock frequency allowed varies with applied supply voltage (V_{DD}).
2. I_{DD} requirement for Xtal/clock frequency of 2.24MHz.
3. Signal input level required to provide a constant autocorrelated output.
4. Measured with a 6.0kHz sinewave at the signal input.
5. Measured with $V_{DD} = 2.5$ volts.
6. Measured with a 12kHz input signal.
7. Recommended input signal frequency range to correlation circuits.
8. Input (Signal In) to output (Output) time with a 2.24MHz Xtal/clock input.

5.2 Packaging

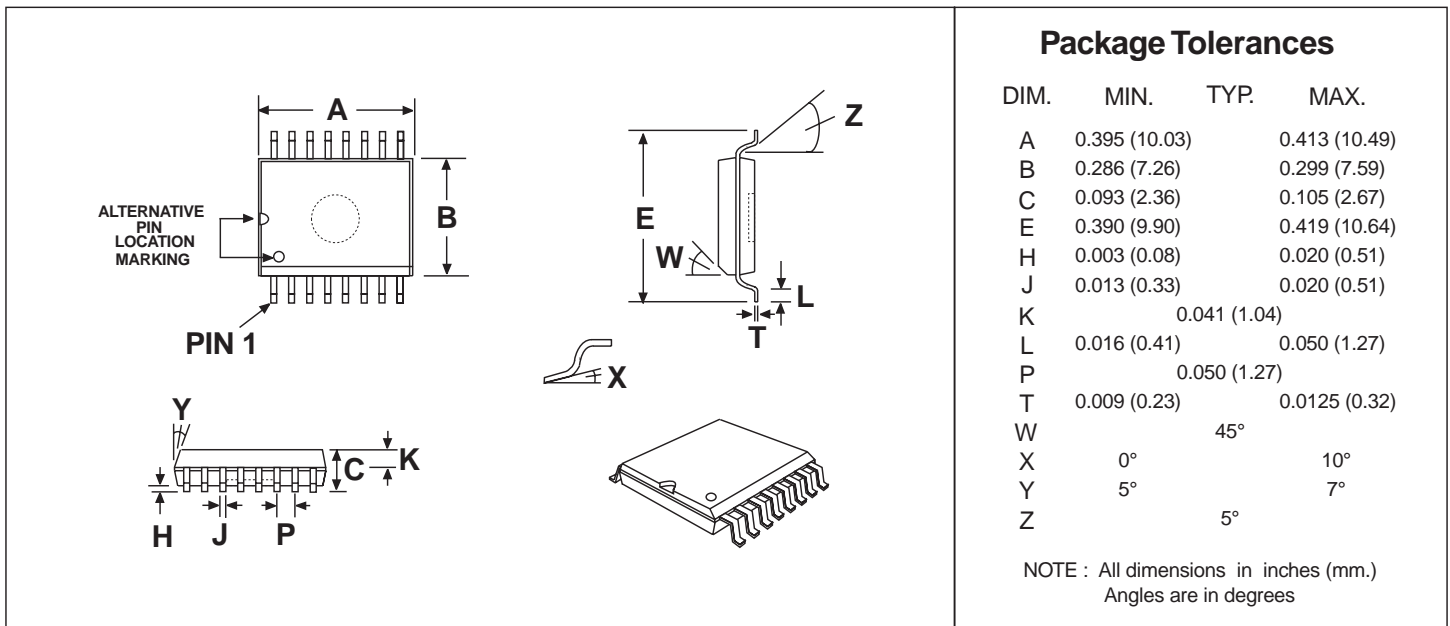

Figure 6: 16-pin SOIC Mechanical Outline: *Order as part no. MX102DW*

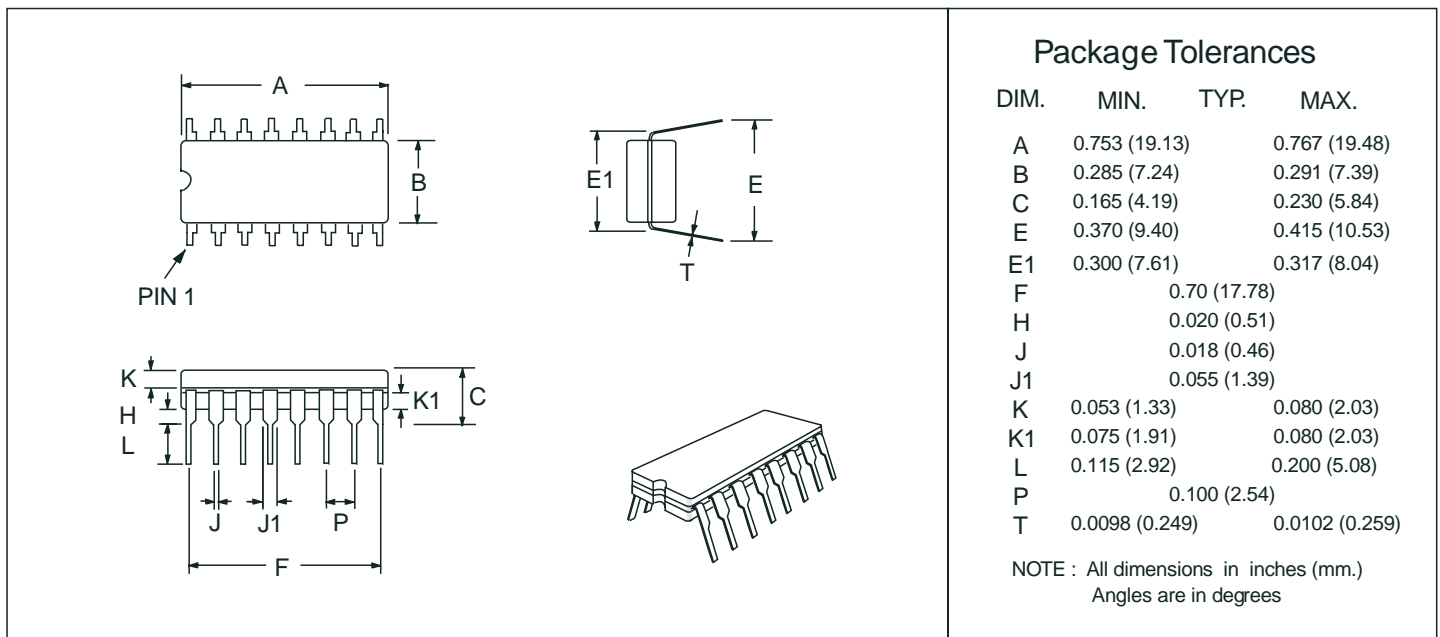

Figure 7: 16-pin CDIP Mechanical Outline: *Order as part no. MX102J*