

10 9 8 7 6 5 4 3 2 1

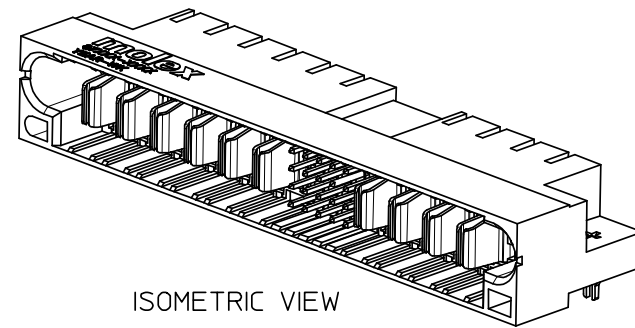

ISOMETRIC VIEW

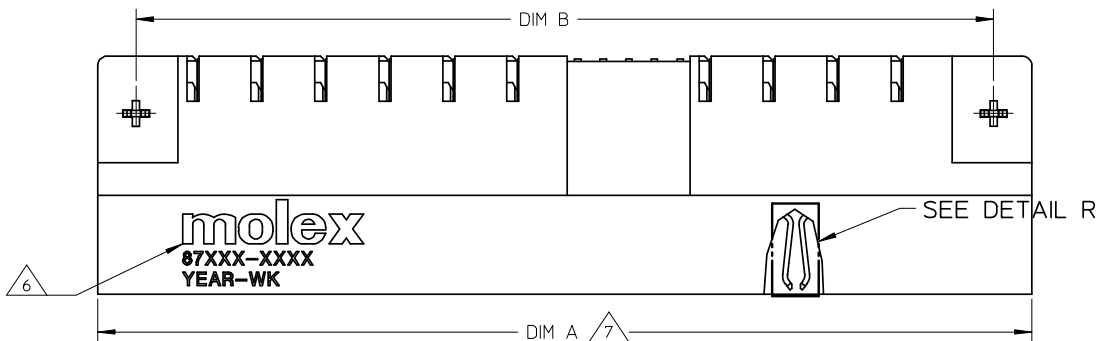
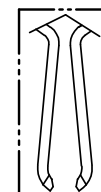
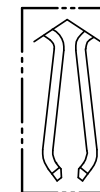
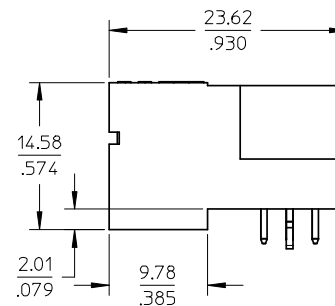
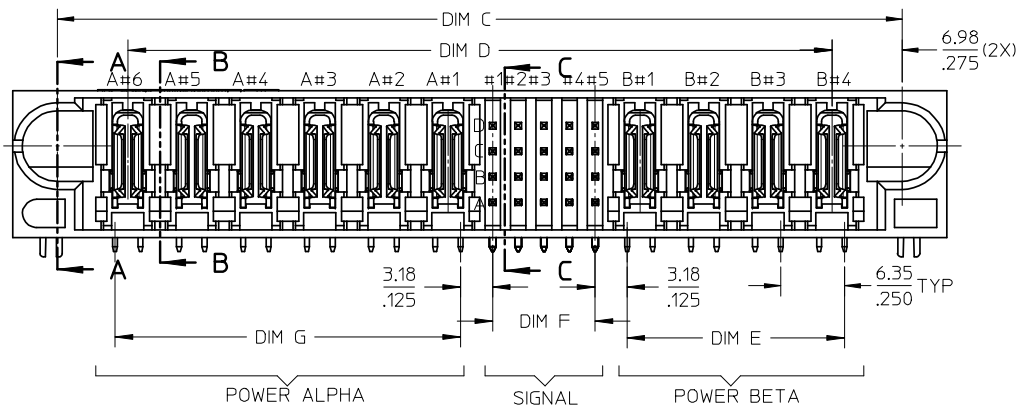

SHORT BLADE OPTION LONG BLADE OPTION

DETAIL R
(SEE TABLE FOR BLADE OPTION)

NOTES:

- MATERIALS: LCP GLASS FILLED , UL94V-0, COLOUR: BLACK
POWER PINS - COPPER ALLOY
SIGNAL PINS - COPPER ALLOY
- FINISHES: POWER & SIGNAL PINS:
SELECTIVE GOLD IN CONTACT AREA.
THICKNESS= 0.76 MICROMETER/ 30 MICROINCH MINIMUM
SELECTIVE TIN THE PC TAIL AREA
THICKNESS= 2.54 MICROMETER/100 MICROINCH MINIMUM
1.27um NICKEL OVERALL.
- PRODUCT SPECIFICATION: PS-87631-006.
- SEE SHEET 2 FOR RECOMMENDED PCB LAYOUT AND THICKNESS.
- COMPONENT STAY AWAY ZONE FROM CONNECTOR.
- MANUFACTURER LOGO, PART NUMBER AND YEAR-WEEK CODE.
- 6P ALPHA-20 SIGNAL-4P BETA CONFIGURATION IS SHOWN FOR ILLUSTRATION. P-S-P CONFIGURATION IS AVAILABLE UP TO 203mm/8 INCHES. PLEASE CONTACT MOLEX SALES PERSONNEL FOR OTHER CONFIGURATION AND OPTION NEEDED.

PDR#S-001800-00-00 EC NO: S2008-1060 DRWN:ATSEE 2008/06/13 CHKD:SKANG 2008/06/13 APPR:MLONG 2008/06/13 D6	QUALITY SYMBOLS ▽=0 ◻=0	GENERAL TOLERANCES (UNLESS SPECIFIED)		DIMENSION STYLE MM/IN		SCALE NTS	DESIGN UNITS METRIC	THIRD ANGLE PROJECTION		
				DRAWN BY BHLW	DATE 2002/09/24	TITLE POWER CONNECTOR HEADER P(A)-S-P(B) CONFIG. R/A, T/H, BOARD-LOCK				
				CHECKED BY KCL ING	DATE 2002/09/30	MOLEX INCORPORATED				
				APPROVED BY SKTOH	DATE 2002/10/03	MATERIAL NO. SEE TABLE	DOCUMENT NO. SD-87631-014	SHEET NO. 1 OF 3		
		DRAFT WHERE APPLICABLE MUST REMAIN WITHIN DIMENSIONS			THIS DRAWING CONTAINS INFORMATION THAT IS PROPRIETARY TO MOLEX INCORPORATED AND SHOULD NOT BE USED WITHOUT WRITTEN PERMISSION					

9 8 7 6 5 4 3 2 1

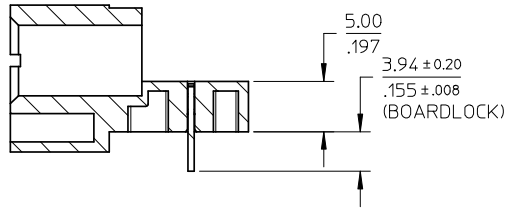

SECTION A-A

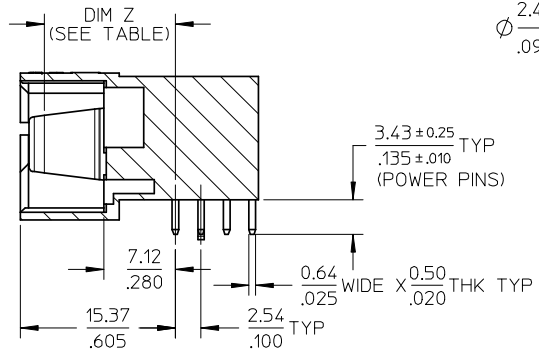

SECTION B-B

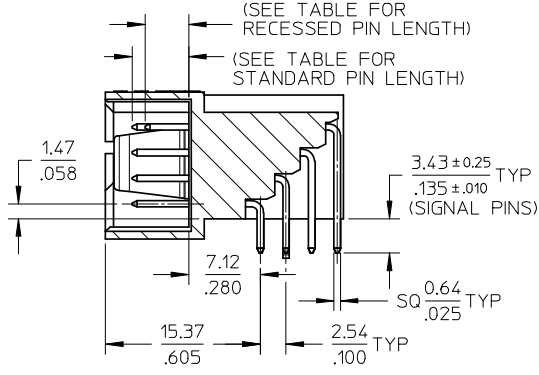

SECTION C-C

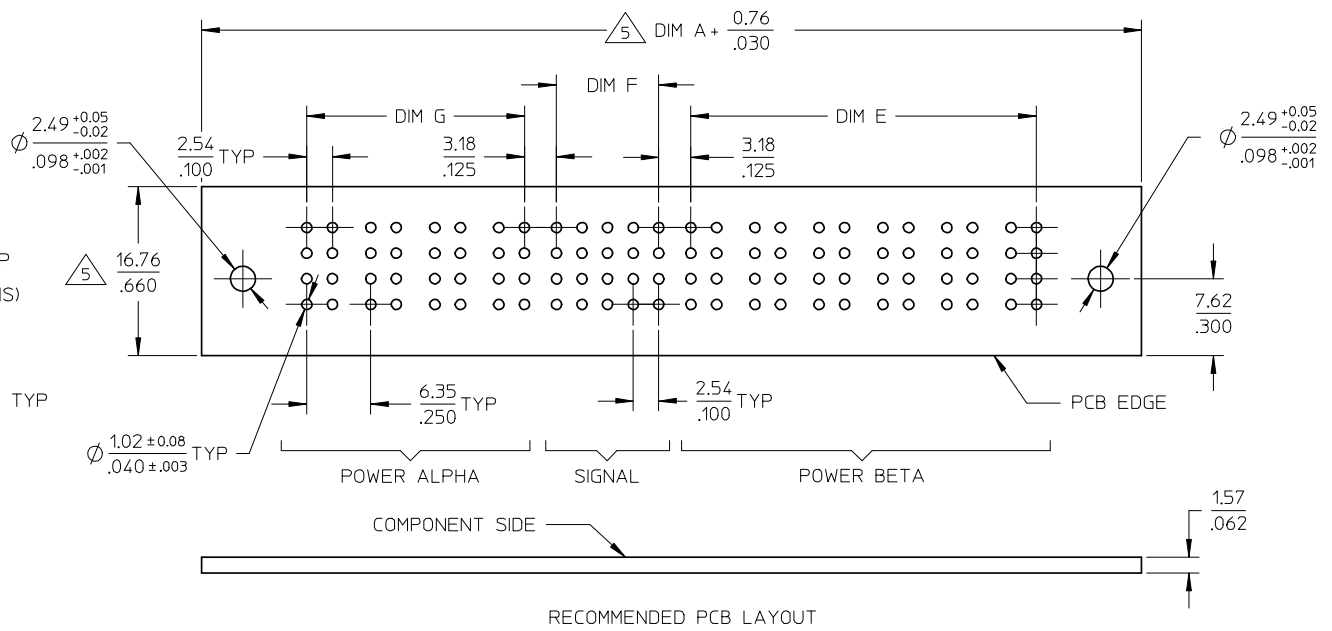

RECOMMENDED PCB LAYOUT

PDR#S-001800-00-00 EC NO: S2008-1060 DRWN:ATSEE 2008/06/13 CHKD:SKANG 2008/06/13 APPR:MLONG 2008/06/13	QUALITY SYMBOLS	GENERAL TOLERANCES (UNLESS SPECIFIED)		DIMENSION STYLE		SCALE	DESIGN UNITS	THIRD ANGLE PROJECTION	
	▽=0 ∇=0	mm	INCH	MM/IN		NTS	METRIC		
		4 PLACES ± --- ± ---	3 PLACES ± --- ± .010	DRAWN BY	DATE	TITLE			
		2 PLACES ± 0.25 ± ---	1 PLACE ± --- ± ---	BHLOW	2002/09/24	POWER CONNECTOR HEADER			
	ANGULAR ± 3 °	DRAFT WHERE APPLICABLE MUST REMAIN WITHIN DIMENSIONS		CHECKED BY	DATE	P(A)-S-P(B) CONFIG.			
				KCL ING	2002/09/30	R/A, T/H, BOARD-LOCK			
				APPROVED BY	DATE	MOLEX INCORPORATED			
				SKTOH	2002/10/03	MATERIAL NO. DOCUMENT NO. SHEET NO.			
				SEE TABLE		SD-87631-014		2 OF 3	
				THIS DRAWING CONTAINS INFORMATION THAT IS PROPRIETARY TO MOLEX INCORPORATED AND SHOULD NOT BE USED WITHOUT WRITTEN PERMISSION					

10		9		8		7		6		5		4		3		2		1	
PART NUMBER	P-S-P CONFIGURATION			DIM A	DIM B	DIM C	DIM D	DIM E	DIM F	DIM G	POWER TYPE	BLADE OPTIONS DIM Z ± 0.13/0.005	STANDARD SIGNAL PIN LENGTH	RECESSED SIGNAL PIN		VOID SIGNAL LOCATION	PACKAGING		
	POWER ALPHA	SIGNAL	POWER BETA											LENGTH	LOCATION				
87631-2001	2	48	2	72.38 2.850	64.77 2.550	63.49 2.500	49.53 1.950	8.89 .350	27.94 1.100	8.89 .350	SHORT CONTACT	13.32/.524	5.59/.220	4.32/.170	A1,A12,D1,D12	NIL	TRAY		
87631-2002	7	32	6	119.38 4.700	111.76 4.400	110.48 4.350	96.52 3.800	34.29 1.350	17.78 .700	40.64 1.600	SHORT CONTACT	13.32/.524	5.59/.220	4.32/.170	A3,B6,C3,D5	NIL			
87631-2003	7	32	6	119.38 4.700	111.76 4.400	110.48 4.350	96.52 3.800	34.29 1.350	17.78 .700	40.64 1.600	LONG CONTACT	14.12/.556	6.86/.270	5.59/.220	A3,B6,C3,D5	NIL			
87631-2004	5	32	5	100.33 3.950	92.71 3.650	91.44 3.600	77.47 3.050	27.94 1.100	17.78 .700	27.94 1.100	LONG CONTACT	14.12/.556	6.45/.254	NIL	NIL	NIL			
87631-2005	2	24	2	57.15 2.250	49.53 1.950	48.26 1.900	34.29 1.350	8.89 .350	12.70 .500	8.89 .350	LONG CONTACT	14.12/.556	6.86/.270	5.59/.220	B3,D3	A6,B6,C5,D5			
87631-2006	4	28	4	85.09 3.350	77.47 3.050	76.20 3.000	62.23 2.450	21.59 .850	15.24 .600	21.59 .850	LONG CONTACT	14.12/.556	6.86/.270	5.59/.220	A1	NIL			
87631-2010	1	16	1	39.37 1.550	31.75 1.250	30.48 1.200	16.51 .650	2.54 .100	7.62 .300	2.54 .100	LONG CONTACT	14.12/.556	6.86/.270	5.59/.220	B1	NIL			
87631-2013	4	40	4	92.71 3.650	85.09 3.350	83.82 3.300	69.85 2.750	21.59 .850	22.86 .900	21.59 .850	LONG CONTACT	14.12/.556	6.86/.270	5.59/.220	A1,A10	NIL			
87631-2014	4	16	2	64.77 2.550	57.15 2.250	55.88 2.200	41.91 1.650	8.89 .350	7.62 .300	21.59 .850	LONG CONTACT	14.12/.556	6.86/.270	5.59/.220	A1,A2,A4,B1B3,C2,C4,D1,D2,D3,D4	NIL			
87631-2019	2	24	2	57.15 2.250	49.53 1.950	48.26 1.900	34.29 1.350	8.89 .350	12.70 .500	8.89 .350	LONG CONTACT	14.12/.556	6.86/.270	5.59/.220	A6,B6,C6,D6	NIL			
87631-2020	2	16	2	52.08 2.050	44.45 1.750	43.19 1.700	29.22 1.150	8.89 .350	7.62 .300	8.89 .350	LONG CONTACT	14.12/.556	6.86/.270	5.59/.220	NIL	NIL			
87631-2021	4	24	2	69.84 2.750	62.23 2.450	60.95 2.400	46.99 1.850	8.89 .350	12.70 .500	21.59 .850	LONG CONTACT	14.12/.556	6.86/.270	5.59/.220	C1	NIL			
87631-2022	6	24	6	107.95 4.250	100.33 3.950	99.06 3.900	85.09 3.350	34.29 1.350	12.70 .500	34.29 1.350	LONG CONTACT	14.12/.556	6.86/.270	5.59/.220	B4	NIL			
87631-2023	3	24	3	69.85 2.750	62.23 2.450	60.96 2.400	46.99 1.850	15.24 0.600	12.70 .500	15.24 0.600	LONG CONTACT	14.12/.556	6.86/.270	5.59/.220	B3,D6	NIL			
87631-2025	6	60	6	130.81 5.150	123.19 4.850	121.92 4.800	107.95 4.250	34.29 1.350	35.56 1.400	34.29 1.350	LONG CONTACT	14.12/.556	6.86/.270	NIL	NIL	NIL			
87631-2026	4	24	4	82.55 3.250	74.93 2.950	73.66 2.900	59.69 2.350	21.59 .850	12.70 .500	21.59 .850	LONG CONTACT	14.12/.556	6.86/.270	NIL	NIL	NIL			
87631-2028	3	24	3	69.85 2.750	62.23 2.450	60.96 2.400	46.99 1.850	15.24 0.600	12.70 .500	15.24 0.600	LONG CONTACT	14.12/.556	6.86/.270	5.59/.220	D2	NIL			
87631-2030	2	24	2	57.15 2.250	49.53 1.950	48.26 1.900	34.29 1.350	8.89 .350	12.70 .500	8.89 .350	LONG CONTACT	14.12/.556	6.86/.270	5.59/.220	C6	NIL			
87631-2032	4	16	2	64.77 2.550	57.15 2.250	55.88 2.200	41.91 1.650	8.89 .350	7.62 .300	21.59 .850	LONG CONTACT	14.12/.556	6.86/.270	5.59/.220	A1,A2,A3,A4,B2,B4,C1,C3,D1,D2,D4	NIL			

PDR#S-001800-00-00 EC NO: S2008-1060 DRW: N/AT/SEE CHKD: SKANG APPR: M/LONG 2008/06/13 2008/06/13 2008/06/13	QUALITY SYMBOLS = 0 = 0	GENERAL TOLERANCES (UNLESS SPECIFIED)		DIMENSION STYLE MM/IN		SCALE NTS	DESIGN UNITS METRIC	THIRD ANGLE PROJECTION			
		4 PLACES ± --- ± --- 3 PLACES ± --- ± .010 2 PLACES ± 0.25 ± --- 1 PLACE ± --- ± ---	mm INCH	DRAWN BY BHL0W	DATE 2002/09/24	TITLE POWER CONNECTOR HEADER P(A)-S-P(B) CONFIG. R/A, T/H, BOARD-LOCK					
		ANGULAR ± 3 °		CHECKED BY KCL ING	DATE 2002/09/30	MOLEX INCORPORATED					
		DRAFT WHERE APPLICABLE MUST REMAIN WITHIN DIMENSIONS		APPROVED BY SKTOH	DATE 2002/10/03	MATERIAL NO. SEE TABLE	DOCUMENT NO. SD-87631-014	SHEET NO. 3 OF 3			