

DESCRIPTION

The LXM1653 floating output drive CCFL (Cold Cathode Fluorescent Lamp) Inverter Module is specifically designed to drive large LCD displays (11.3" and larger), which are used in notebook computers. This new inverter was specifically designed to reduce the leakage currents from the lamp to the reflector or the metal frame of the panels. The floating output architecture of this inverter also permits a much wider dimming range when compared to non-floating designs, and allows an additional 10% efficiency improvement.

The module converts unregulated DC voltage from the system battery or AC adapter directly to high-frequency, high-voltage sine waves required to ignite and operate CCFL lamps. The module design is based on a proprietary Linfinité IC that provides important new performance advances.

Remarkable improvements in efficiency and RF emissions result from this *single* stage resonant inverter, featuring a patented Current Synchronous, Zero Voltage Switching (CS-ZVS) topology. CS-ZVS produces nearly pure sine wave currents in the lamp,

enabling maximum light delivery, while reducing both conducted and radiated noise. This topology simultaneously performs two tasks including line voltage regulation and lamp dimming through lamp current regulation. These two functions are performed in a single power stage made up of a pair of low-loss MOSFETs. The MOSFETs drive a low current resonant circuit that feeds the primary of a high-voltage transformer with a sinusoidal voltage.

Required L and C values in the resonant circuit are such that very low-loss components can be used to obtain higher electrical efficiency than is possible with previous topologies.

The full-bridge LXM1653 provides peak efficiency when operated at input voltages from 6.5 volts to 18 volts.

In addition, this module is equipped with a dimming input that permits full range brightness control from an external potentiometer or PWM signal, and a sleep input that reduces module power to a few microwatts in shut-down mode.

Output open and short circuit protection are also featured on this module.

KEY FEATURES

- FULLY FLOATING OUTPUT
- 35% MORE LIGHT OUTPUT AT 5 WATTS
- GREATER EFFICIENCY THAN GROUNDED OUTPUT DESIGNS
- 6.5V TO 18V INPUT VOLTAGE RANGE
- VERSATILE BRIGHTNESS CONTROL INPUT
- 10 MICROAMP SLEEP CURRENT
- OUTPUT SHORT CIRCUIT PROTECTION AND AUTOMATIC OVER VOLTAGE LIMITING
- 7.4mm MAX HEIGHT, NARROW FOOTPRINT
- MINIMIZE THERMOMETER EFFECTS
- MINIMIZE LAMP TO PANEL LEAKAGE CURRENT

APPLICATIONS

- 11.3" LCD PANELS AND LARGER
- NOTEBOOK AND SUB-NOTEBOOK COMPUTERS
- PORTABLE INSTRUMENTATION
- AUTOMOTIVE DISPLAYS
- DESKTOP DISPLAYS
- AIRLINE ENTERTAINMENT CENTERS

BENEFITS

- ULTRA-HIGH EFFICIENCY, LINE VOLTAGE REGULATION AND SLEEP MODE EXTEND COMPUTER BATTERY LIFE
- COOL OPERATION PERMITS CLOSE PROXIMITY TO LCD PANEL WITHOUT DISPLAY DISTORTION
- SMOOTH, FULL-RANGE BRIGHTNESS CONTROL GIVES YOUR PRODUCT A HIGH QUALITY IMAGE
- LOW EMI / RFI DESIGN MINIMIZES SHIELDING REQUIREMENTS
- NARROW, LOW-PROFILE MODULE FITS INTO MOST LCD ENCLOSURES

PRODUCT HIGHLIGHT

FLOATING OUTPUT ARCHITECTURE

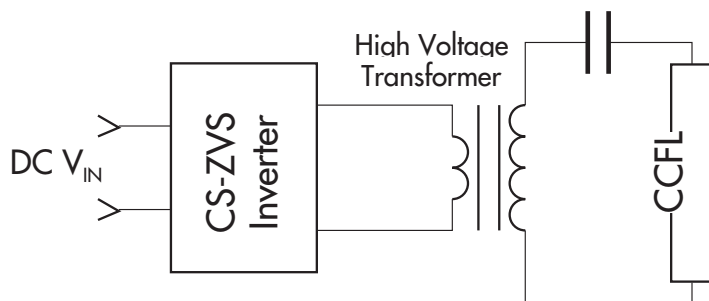

MODULE ORDER INFO

FULL-BRIDGE DRIVE

LXM1653-01

FOR FURTHER INFORMATION CALL (714) 898-8121

ABSOLUTE MAXIMUM RATINGS (Note 1)

Input Supply Voltage (V_{IN}).....	6.5V to 18V
Output Voltage, no load	Internally Limited to $2000V_{RMS}$
Output Current	$7.5mA_{RMS}$ (Internally Limited)
Output Power	6W
Input Signal Voltage, (SLEEP and BRITE Inputs)	-0.3V to 6.5V
Ambient Operating Temperature, zero airflow	0°C to 60°C
Storage Temperature Range	-40°C to 85°C

Note 1. Exceeding these ratings could cause damage to the device. All voltages are with respect to Ground. Currents are positive into, negative out of the specified terminal.

RECOMMENDED OPERATING CONDITIONS (R.C.)

This module has been designed to operate over a wide range of input and output conditions. However, best efficiency and performance will be obtained if the module is operated under the condition listed in the 'R.C.' column. Min. and Max. columns indicate values beyond which the inverter, although operational, will not function optimally.

Parameter	Symbol	Recommended Operating Conditions			Units
		Min.	R.C.	Max.	
Input Supply Voltage		6.5		18	V
Output Power	P_O		4.0	6.0	W
Brightness Control Input Voltage Range	V_{BRITE}	0.0		2.0	V
Lamp Operating Voltage	V_{LAMP}	300	600	800	V_{RMS}
Lamp Current - Full Brightness	I_{OLAMP}		7.2		mA_{RMS}
Operating Ambient Temperature Range	T_A	0		60	°C

ELECTRICAL CHARACTERISTICS

Unless otherwise specified, these specifications apply over the recommended operating conditions and 25°C ambient temperature for the LXM1653.

Parameter	Symbol	Test Conditions	LXM1653			Units
			Min.	Typ.	Max.	
Output Pin Characteristics						
Full Bright Lamp Current	$I_L (MAX)$	$V_{BRITE} = 2.0 V_{DC}, V_{LAMP} = 750V_{RMS}, V_{IN} \geq 10.8V_{DC}$	6.8	7.2	7.7	mA
		$V_{BRITE} = 2.0 V_{DC}, V_{LAMP} = 750V_{RMS}, V_{IN} \geq 9.0V_{DC}$	5.0	5.5		mA
		$V_{BRITE} = 2.0 V_{DC}, V_{LAMP} = 350V_{RMS}, V_{IN} \geq 6.5V_{DC}$	6.8	7.2		mA
		$V_{BRITE} = 2.0 V_{DC}, V_{LAMP} = 600V_{RMS}, V_{IN} \geq 8.0V_{DC}$	6.8	7.2		mA
Minimum Lamp Current	$I_L (MIN)$	$V_{BRITE} = 0.0 V_{DC}$		2.5		mA_{RMS}
Lamp Start Voltage	V_{LS}	0°C < T_A < 60°C	1800			V_{RMS}
Operating Frequency	f_O	$V_{BRITE} = 2.5V_{DC}, \overline{SLEEP} = \text{Logic High}, V_{IN} = 12V$	55	60	65	KHz
Brightness Control						
Input Current	I_{BRITE}	$V_{BRITE} = 0V_{DC}$		-200	-1000	nA_{DC}
Input Voltage for Max. Lamp Current	V_C	$I_{O(LAMP)} = 100\%$	2.4	2.5	2.6	V_{DC}
Input Voltage for 50% Lamp Current	V_C	$I_{O(LAMP)} = 50\%$		1.25		V_{DC}
SLEEP Input						
Input Logic 1	V_{IH}		2.5		5.5	V_{DC}
Input Logic 0	V_{IL}		0		0.8	V_{DC}
Input Current	I_{IN}	$V_{SLEEP} = 0 - 5V_{DC}$		50	100	μA_{DC}
Voltage Reference						
Output Voltage	V_{REF}	$0 < I_{REF} < 500\mu A$	2.40	2.50	2.60	V_{DC}
Output Current	I_{REF}		500			μA_{DC}
Power Characteristics						
Sleep Current	$I_{IN (MIN)}$	$V_{IN} = 12V, \overline{SLEEP} = \text{Logic 0}$		10	30	μA_{DC}

FLOATING OUTPUT DRIVE, CCFL INVERTER MODULES

FUNCTIONAL PIN DESCRIPTION

Conn.	Pin	Description
CN1		
CN1-1 CN1-2	V_{IN}	Input voltage. (+6.5 to +18V _{DC})
CN1-3 CN1-4	GND	Power supply return.
CN1-5	\overline{SLEEP}	Logical high on this pin enables inverter operation. Logical low removes power from the module and the lamp. A floating input is sensed as a logical low and will disable inverter operation. If not used, connect \overline{SLEEP} to V_{IN} .
CN1-6	BRITE	Brightness control input. Apply 0.0 to 2.0 volts DC to control lamp brightness. Lamp current varies linearly with input voltage. Open circuit or 2.0V gives maximum brightness. This input may also be driven with a PWM logic signal. See Application Notes Section.
CN1-7	AGND	Brightness control signal return. For best results do not run V_{IN} power supply return current through this pin.
CN1-8	V_{REF}	Reference Voltage Output. 2.5V @ 500 μ A max. For use with external dimming circuit.
CN2		
CN2-1	LAMP HI	High-voltage connection to high side of lamp. Connect to lamp terminal with shortest lead length. Do not connect to ground.
CN2-2	LAMP LO	High-voltage connection to low side of lamp. Connect to lamp terminal with longer lead length. This lead may be safely connected to ground, but may not result in specified performance depending on system wiring and lamp characteristics.

APPLICATION DIAGRAM

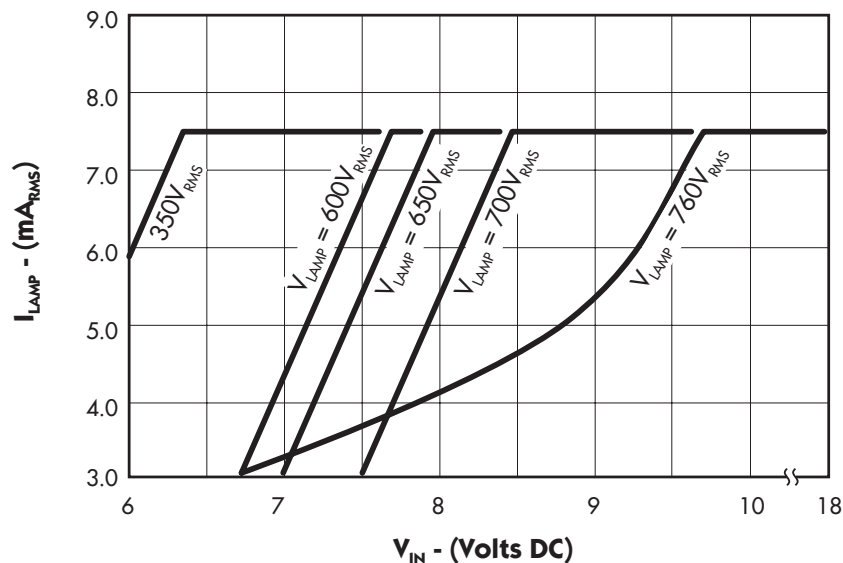

FIGURE 1 — MAXIMUM LAMP CURRENT vs. INPUT VOLTAGE FOR TYPICAL LAMP VOLTAGES

TYPICAL APPLICATIONS

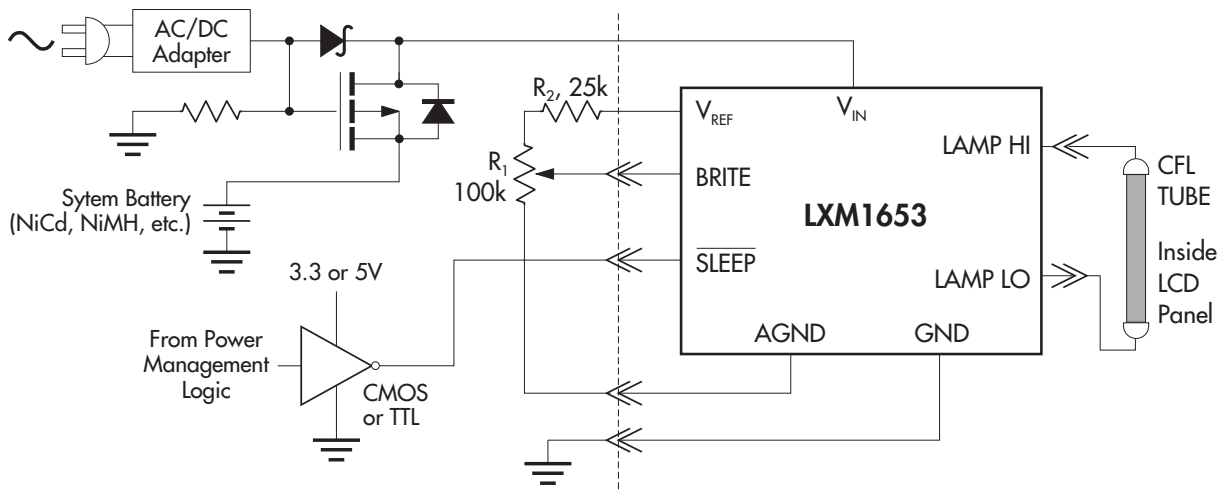

FIGURE 21 — NOTEBOOK SYSTEM APPLICATION

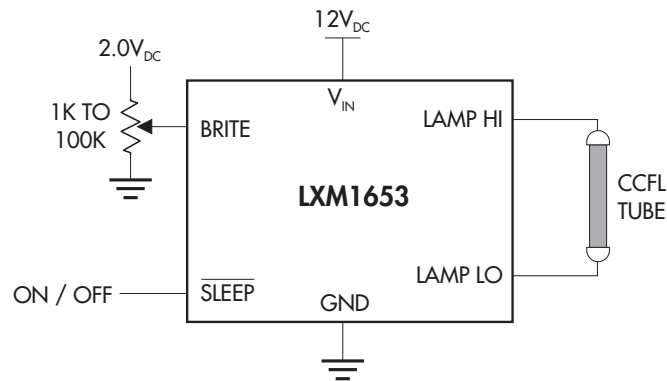
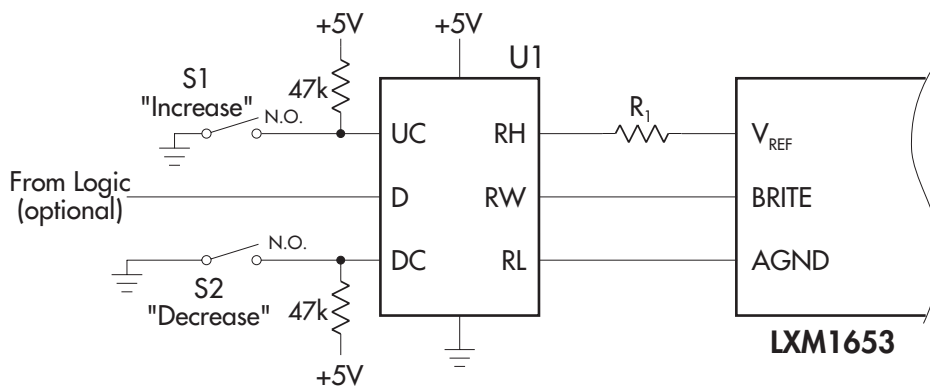

FIGURE 22 — POTENTIOMETER BRIGHTNESS CONTROL



- S1 & S2 are momentary push buttons, normally open contacts.
- U1 = 100k digital pot.
- R₁ value optional for choosing dimming range.

FIGURE 23 — NONVOLATILE DIGITAL BRIGHTNESS CONTROL

TYPICAL APPLICATIONS (continued)

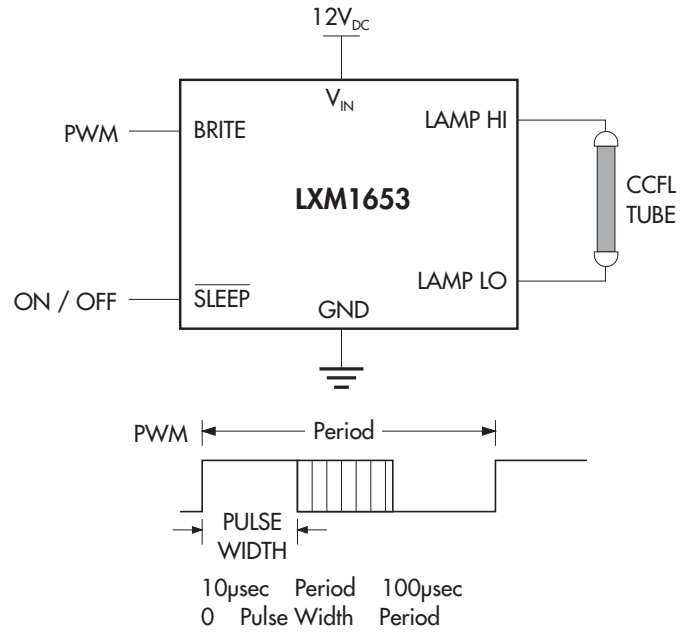
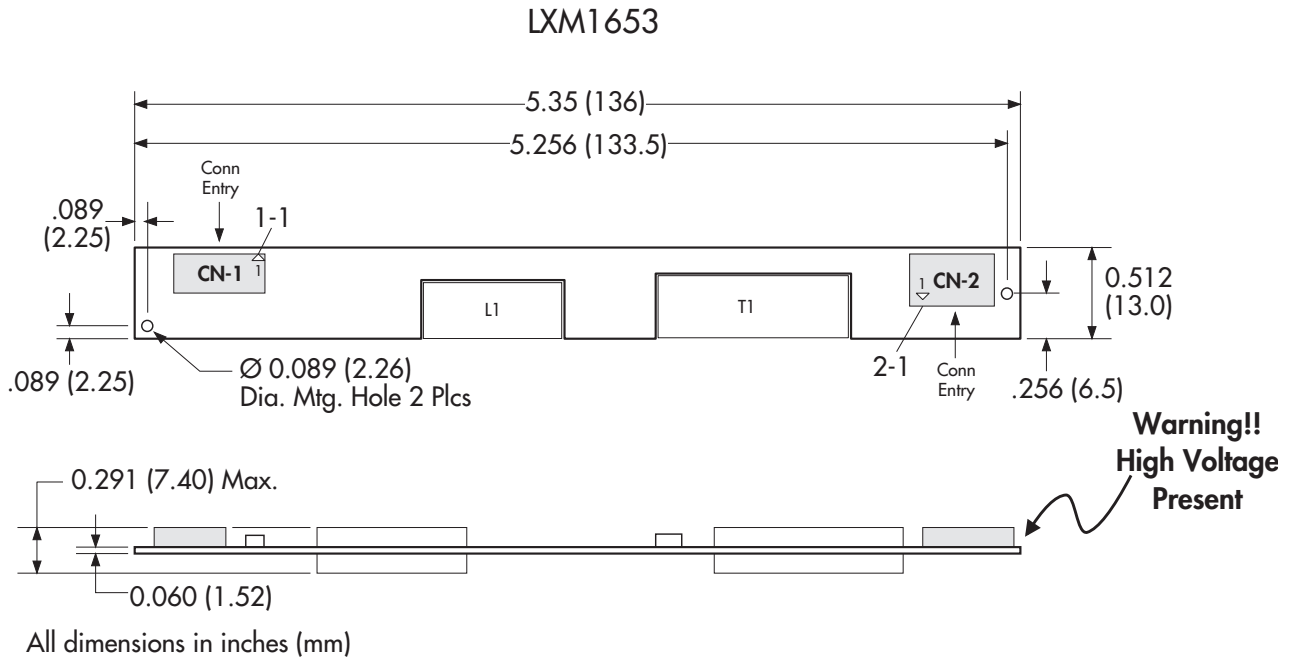

FIGURE 24 — PWM BRIGHTNESS CONTROL

PHYSICAL DIMENSIONS



CN-1 = MOLEX P/N: 53261-0890

CN-2 = JST P/N: SM02-(8.0)B-BHS-1D