

PMEM4020APD

www.DataSheet4U.com

PNP transistor/Schottky rectifier module

Rev. 01 — 4 October 2004

Product data sheet

1. Product profile

1.1 General description

Combination of a PNP transistor with low V_{CEsat} and high current capability and a planar Schottky barrier rectifier with an integrated guard ring for stress protection in a SOT457 (SC-74) small plastic package. NPN complement: PMEM4020AND.

1.2 Features

- 600 mW total power dissipation
- High current capability up to 2 A
- Reduces printed-circuit board area required
- Reduces pick and place costs
- Small plastic SMD package
- Transistor
 - ◆ Low collector-emitter saturation voltage.
- Diode
 - ◆ Ultra high-speed switching
 - ◆ Very low forward voltage
 - ◆ Guard ring protected.

1.3 Applications

- DC-to-DC converters
- Inductive load drivers
- General purpose load drivers
- Reverse polarity protection circuits
- MOSFET drivers.

1.4 Quick reference data

Table 1: Quick reference data

Symbol	Parameter	Conditions	Min	Typ	Max	Unit
PNP transistor						
V_{CEO}	collector-emitter voltage	open base	-	-	-40	V
I_C	collector current (DC)	continuous; $T_s \leq 55\text{ °C}$	[1] -	-	-2	A

PHILIPS

Table 1: Quick reference data ...continued

Symbol	Parameter	Conditions	Min	Typ	Max	Unit
Schottky barrier rectifier						
V_R	continuous reverse voltage		-	-	40	V
I_F	continuous forward current		-	-	1	A

[1] Soldering point of collector or cathode tab.

2. Pinning information

Table 2: Discrete pinning

Pin	Description	Simplified outline	Symbol
1	emitter	<p style="text-align: center;">SOT457</p>	<p style="text-align: center;">sym040</p>
2	not connected		
3	cathode		
4	anode		
5	base		
6	collector		

3. Ordering information

Table 3: Ordering information

Type number	Package		
	Name	Description	Version
PMEM4020APD	SC-74	plastic surface mounted package; 6 leads	SOT457

4. Marking

Table 4: Marking

Type number	Marking code
PMEM4020APD	D3

5. Limiting values

Table 5: Limiting values

In accordance with the Absolute Maximum Rating System (IEC 60134).

Symbol	Parameter	Conditions	Min	Max	Unit
PNP transistor					
V_{CBO}	collector-base voltage	open emitter	-	-40	V
V_{CEO}	collector-emitter voltage	open base	-	-40	V
V_{EBO}	emitter-base voltage	open collector	-	-5	V

Table 5: Limiting values ...continued
In accordance with the Absolute Maximum Rating System (IEC 60134).

Symbol	Parameter	Conditions	Min	Max	Unit
I _C	collector current (DC)	continuous	[1] -	-0.75	A
		continuous	[2] -	-1	A
		continuous	[3] -	-1.3	A
		continuous; T _s ≤ 55 °C	[4] -	-2	A
I _{CM}	peak collector current		-	-3	A
I _{BM}	peak base current		-	-1	A
P _{tot}	total power dissipation	T _{amb} ≤ 25 °C	[1] -	295	mW
		T _{amb} ≤ 25 °C	[2] -	400	mW
		T _{amb} ≤ 25 °C	[3] -	500	mW
		T _s ≤ 55 °C	[4] -	1000	mW
T _j	junction temperature		-	150	°C
Schottky barrier rectifier					
V _R	continuous reverse voltage		-	40	V
I _F	continuous forward voltage		-	1	A
I _{FRM}	repetitive peak forward current	t _p ≤ 1 ms; δ ≤ 0.5	-	3.5	A
I _{FSM}	non-repetitive peak forward current	t = 8 ms; square wave	-	10	A
P _{tot}	total power dissipation	T _{amb} ≤ 25 °C	[1] -	295	mW
		T _{amb} ≤ 25 °C	[2] -	400	mW
		T _{amb} ≤ 25 °C	[3] -	500	mW
		T _s ≤ 55 °C	[4] -	1000	mW
T _j	junction temperature		[2] -	150	°C
Combined device					
P _{tot}	total power dissipation	T _{amb} ≤ 25 °C	[2] -	600	mW
T _{stg}	storage temperature		-65	+150	°C
T _{amb}	ambient temperature		[2] -65	+150	°C

- [1] Mounted on a FR4 printed-circuit board, single-sided copper, tin-plated, standard footprint.
- [2] Device mounted on a printed-circuit board, single-sided copper, tin-plated, 1 cm² mounting pad for both collector and cathode.
- [3] Mounted on a ceramic printed-circuit board, single-sided copper, tin-plated, standard footprint.
- [4] Soldering point of collector or cathode tab.

6. Thermal characteristics

Table 6: Thermal characteristics [1]

Symbol	Parameter	Conditions	Min	Typ	Max	Unit
Single device						
$R_{th(j-s)}$	thermal resistance from junction to soldering point	in free air	[2] -	-	95	K/W
$R_{th(j-a)}$	thermal resistance from junction to ambient	in free air	[3] -	-	250	K/W
			[4] -	-	315	K/W
			[5] -	-	425	K/W
Combined device						
$R_{th(j-a)}$	thermal resistance from junction to ambient	in free air	[3] -	-	208	K/W

[1] For Schottky barrier rectifiers thermal run-away has to be considered, as in some applications the reverse power losses P_R are a significant part of the total power losses. Nomograms for determining the reverse power losses P_R and $I_{F(AV)}$ rating will be available on request.

[2] Soldering point of collector or cathode tab.

[3] Mounted on a ceramic printed-circuit board, single-sided copper, tin-plated, standard footprint.

[4] Device mounted on a printed-circuit board, single-sided copper, tin-plated, 1 cm² mounting pad for both collector and cathode tab.

[5] Mounted on a FR4 printed-circuit board, single-sided copper, tin-plated, standard footprint.

7. Characteristics

Table 7: Characteristics
 $T_{amb} = 25\text{ °C}$ unless otherwise specified.

Symbol	Parameter	Conditions	Min	Typ	Max	Unit
PNP transistor						
I_{CBO}	collector-base cut-off current	$V_{CB} = -40\text{ V}; I_E = 0\text{ A}$	-	-	-100	nA
		$V_{CB} = -40\text{ V}; I_E = 0\text{ A}; T_j = 150\text{ °C}$	-	-	-50	μA
I_{CEO}	collector-emitter cut-off current	$V_{CE} = -30\text{ V}; I_B = 0\text{ A}$	-	-	-100	nA
I_{EBO}	emitter-base cut-off current	$V_{EB} = -5\text{ V}; I_C = 0\text{ A}$	-	-	-100	nA
h_{FE}	DC current gain	$V_{CE} = -5\text{ V}; I_C = -1\text{ mA}$	300	-	-	
		$V_{CE} = -5\text{ V}; I_C = -100\text{ mA}$	300	-	-	
		$V_{CE} = -5\text{ V}; I_C = -500\text{ mA}$	250	-	900	
		$V_{CE} = -5\text{ V}; I_C = -1\text{ A}$	160	-	-	
		$V_{CE} = -5\text{ V}; I_C = -2\text{ A}$	[1] 50	-	-	
V_{CEsat}	collector-emitter saturation voltage	$I_C = -100\text{ mA}; I_B = -1\text{ mA}$	-	-	-120	mV
		$I_C = -500\text{ mA}; I_B = -50\text{ mA}$	-	-	-145	mV
		$I_C = -1\text{ A}; I_B = -100\text{ mA}$	-	-	-260	mV
		$I_C = -2\text{ A}; I_B = -200\text{ mA}$	-	-	-530	mV
R_{CEsat}	equivalent on-resistance	$I_C = -1\text{ A}; I_B = -100\text{ mA}$	[1] -	180	280	$\text{m}\Omega$
V_{BEsat}	base-emitter saturation voltage	$I_C = -1\text{ A}; I_B = -100\text{ mA}$	[1] -	-	-1.1	V
V_{BEon}	base-emitter turn-on voltage	$V_{CE} = -5\text{ V}; I_C = -1\text{ A}$	[1] -	-	-1.0	V
f_T	transition frequency	$V_{CE} = -10\text{ V}; I_C = -50\text{ mA}; f = 100\text{ MHz}$	150	-	-	MHz
C_c	collector capacitance	$V_{CB} = -10\text{ V}; I_E = I_e = 0\text{ A}; f = 1\text{ MHz}$	-	-	10	pF
Schottky barrier rectifier						
V_F	continuous forward voltage	see Figure 1				
		$I_F = 0.1\text{ mA}$	[1] -	95	130	mV
		$I_F = 1\text{ mA}$	[1] -	155	210	mV
		$I_F = 10\text{ mA}$	[1] -	220	270	mV
		$I_F = 100\text{ mA}$	[1] -	295	350	mV
		$I_F = 1000\text{ mA}$	[1] -	540	640	mV
I_R	reverse current	see Figure 2				
		$V_R = 10\text{ V}$	[1] -	7	20	μA
		$V_R = 40\text{ V}$	[1] -	30	100	μA
C_d	diode capacitance	$V_R = 1\text{ V}; f = 1\text{ MHz};$ see Figure 3	-	43	48	pF

[1] Pulse test: $t_p \leq 300\text{ }\mu\text{s}; \delta \leq 0.02$.

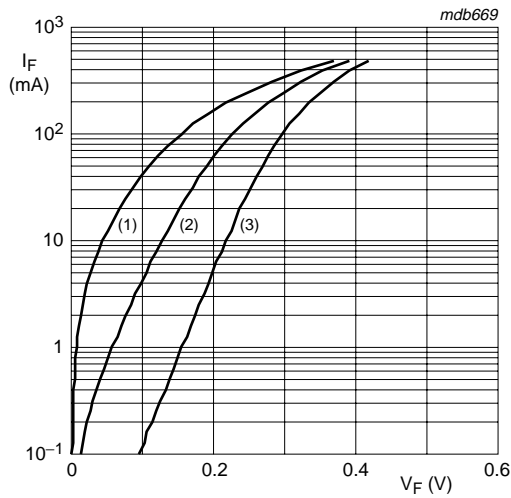

Schottky barrier rectifier.

- (1) $T_{amb} = 150\text{ }^{\circ}\text{C}$.
- (2) $T_{amb} = 85\text{ }^{\circ}\text{C}$.
- (3) $T_{amb} = 25\text{ }^{\circ}\text{C}$.

Fig 1. Forward current as a function of forward voltage; typical values.

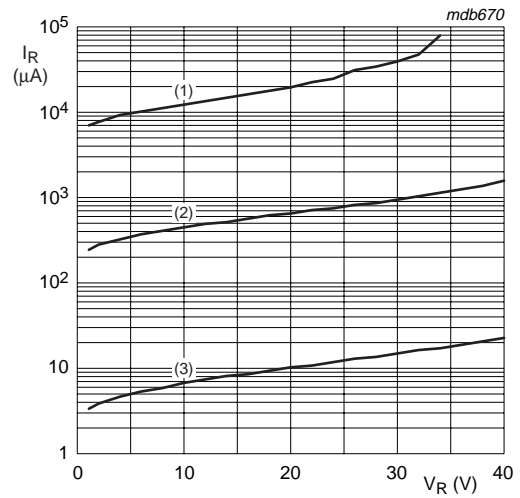

Schottky barrier rectifier.

- (1) $T_{amb} = 150\text{ }^{\circ}\text{C}$.
- (2) $T_{amb} = 85\text{ }^{\circ}\text{C}$.
- (3) $T_{amb} = 25\text{ }^{\circ}\text{C}$.

Fig 2. Reverse current as a function of reverse voltage; typical values.

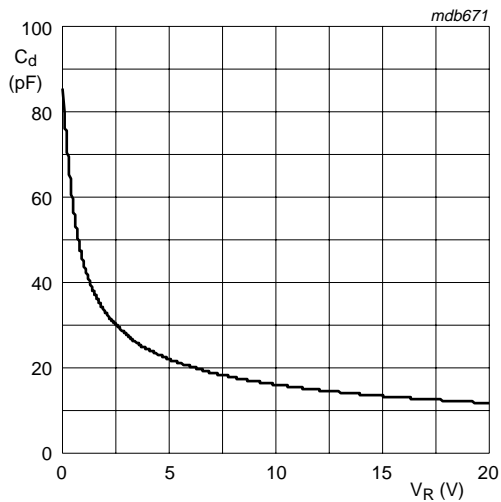

Schottky barrier rectifier;

$T_{amb} = 25\text{ }^{\circ}\text{C}$; $f = 1\text{ MHz}$.

Fig 3. Diode capacitance as a function of reverse voltage; typical values.

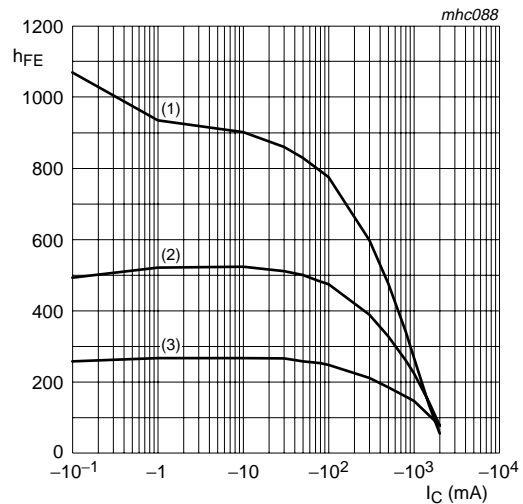

PNP transistor; $V_{CE} = -5\text{ V}$.

- (1) $T_{amb} = 150\text{ }^{\circ}\text{C}$.
- (2) $T_{amb} = 25\text{ }^{\circ}\text{C}$.
- (3) $T_{amb} = -55\text{ }^{\circ}\text{C}$.

Fig 4. DC current gain as a function of collector current; typical values.

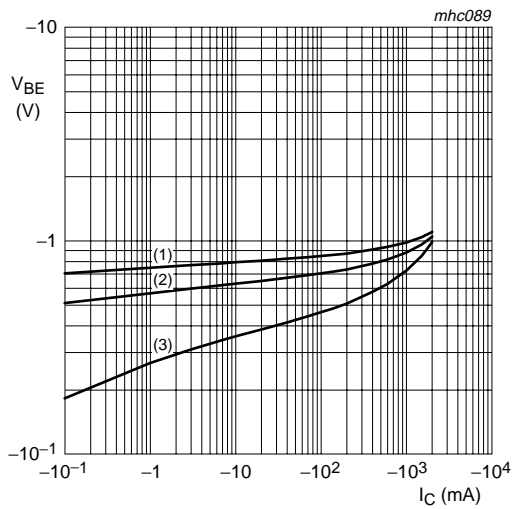

PNP transistor; $V_{CE} = -5$ V.

- (1) $T_{amb} = -55$ °C.
- (2) $T_{amb} = 25$ °C.
- (3) $T_{amb} = 150$ °C.

Fig 5. Base-emitter voltage as a function of collector current; typical values.

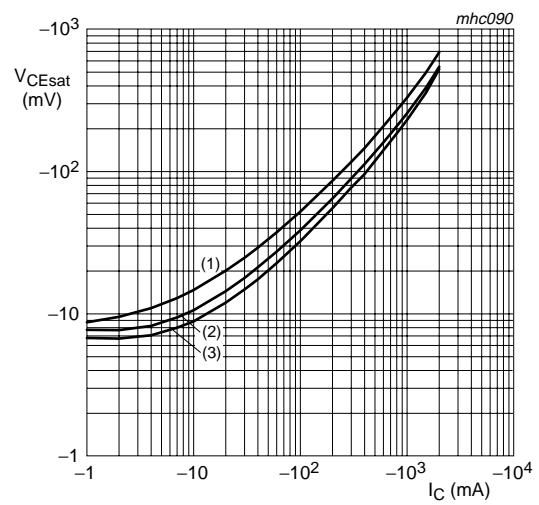

PNP transistor; $I_C/I_B = 10$.

- (1) $T_{amb} = 150$ °C.
- (2) $T_{amb} = 25$ °C.
- (3) $T_{amb} = -55$ °C.

Fig 6. Collector-emitter saturation voltage as a function of collector current; typical values.

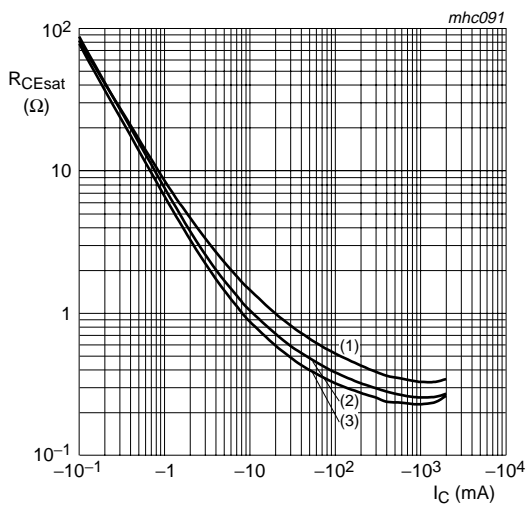

PNP transistor; $I_C/I_B = 10$.

- (1) $T_{amb} = 150$ °C.
- (2) $T_{amb} = 25$ °C.
- (3) $T_{amb} = -55$ °C.

Fig 7. Equivalent on-resistance as a function of collector current; typical values.

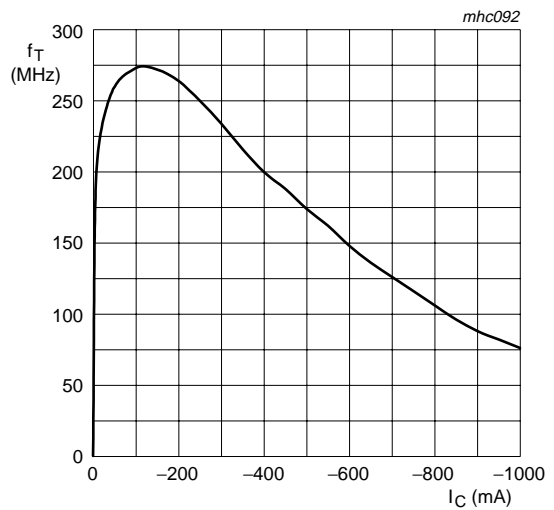

PNP transistor; $V_{CE} = -10$ V.

Fig 8. Transition frequency as a function of collector current.

8. Application information

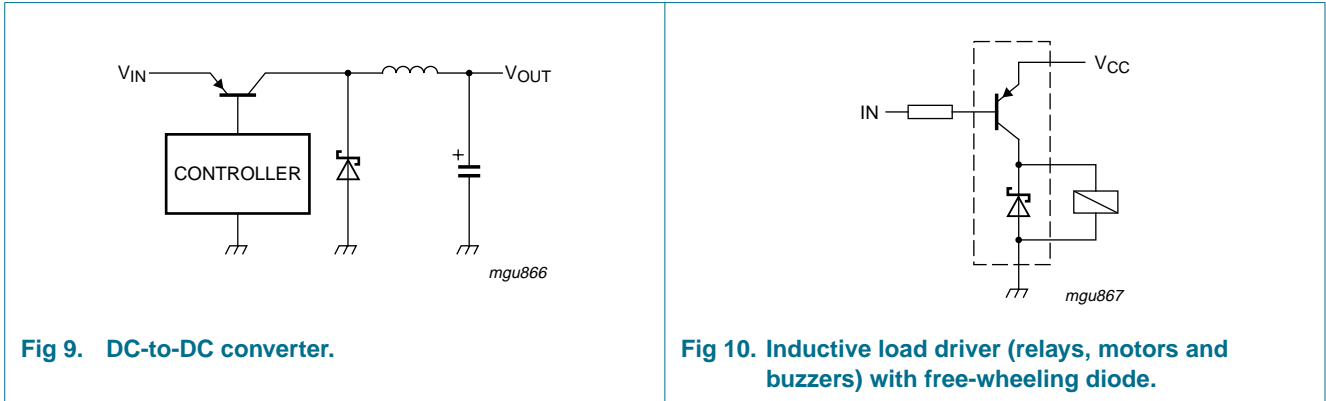

9. Package outline

Plastic surface mounted package; 6 leads

SOT457

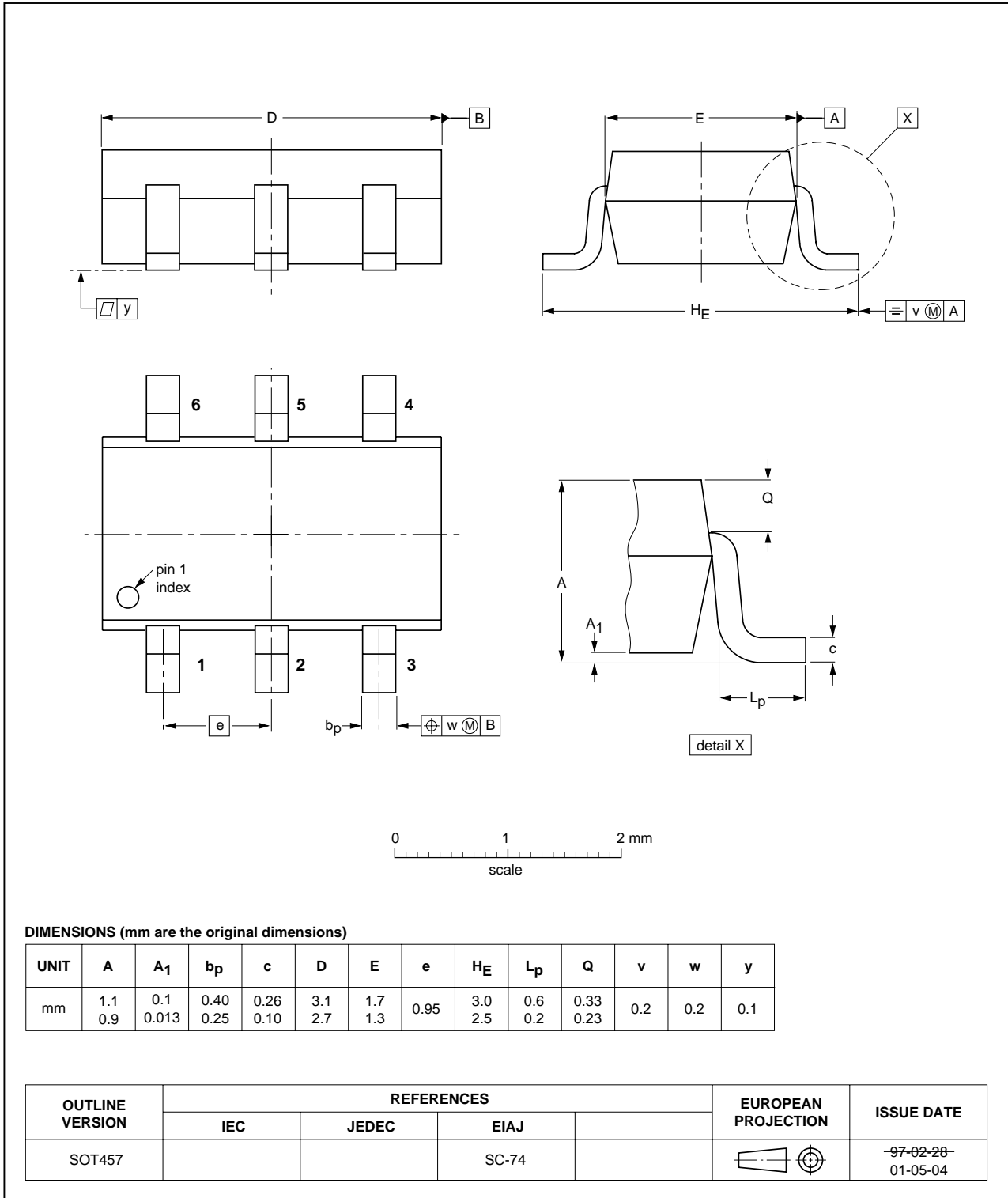

Fig 11. Package outline SOT457 (SC-74).

10. Packing information

Table 8: Packing methods

The indicated -xxx are the last three digits of the 12NC ordering code. [\[1\]](#)

Type number	Package	Description	Packing quantity	
			3000	10000
PMEM4020APD	SOT457	4 mm pitch, 8 mm tape and reel; T1	-115	-135
		4 mm pitch, 8 mm tape and reel; T2	-125	-165

[1] For further information and the availability of packing methods, see [Section 15.S](#)



11. Revision history

Table 9: Revision history

Document ID	Release date	Data sheet status	Change notice	Order number	Supersedes
PMEM4020APD_1	20041004	Product data sheet	-	9397 750 13707	-

12. Data sheet status

Level	Data sheet status ^[1]	Product status ^[2] ^[3]	Definition
I	Objective data	Development	This data sheet contains data from the objective specification for product development. Philips Semiconductors reserves the right to change the specification in any manner without notice.
II	Preliminary data	Qualification	This data sheet contains data from the preliminary specification. Supplementary data will be published at a later date. Philips Semiconductors reserves the right to change the specification without notice, in order to improve the design and supply the best possible product.
III	Product data	Production	This data sheet contains data from the product specification. Philips Semiconductors reserves the right to make changes at any time in order to improve the design, manufacturing and supply. Relevant changes will be communicated via a Customer Product/Process Change Notification (CPCN).

[1] Please consult the most recently issued data sheet before initiating or completing a design.

[2] The product status of the device(s) described in this data sheet may have changed since this data sheet was published. The latest information is available on the Internet at URL <http://www.semiconductors.philips.com>.

[3] For data sheets describing multiple type numbers, the highest-level product status determines the data sheet status.

13. Definitions

Short-form specification — The data in a short-form specification is extracted from a full data sheet with the same type number and title. For detailed information see the relevant data sheet or data handbook.

Limiting values definition — Limiting values given are in accordance with the Absolute Maximum Rating System (IEC 60134). Stress above one or more of the limiting values may cause permanent damage to the device. These are stress ratings only and operation of the device at these or at any other conditions above those given in the Characteristics sections of the specification is not implied. Exposure to limiting values for extended periods may affect device reliability.

Application information — Applications that are described herein for any of these products are for illustrative purposes only. Philips Semiconductors make no representation or warranty that such applications will be suitable for the specified use without further testing or modification.

14. Disclaimers

Life support — These products are not designed for use in life support appliances, devices, or systems where malfunction of these products can reasonably be expected to result in personal injury. Philips Semiconductors customers using or selling these products for use in such applications do so at their own risk and agree to fully indemnify Philips Semiconductors for any damages resulting from such application.

Right to make changes — Philips Semiconductors reserves the right to make changes in the products - including circuits, standard cells, and/or software - described or contained herein in order to improve design and/or performance. When the product is in full production (status 'Production'), relevant changes will be communicated via a Customer Product/Process Change Notification (CPCN). Philips Semiconductors assumes no responsibility or liability for the use of any of these products, conveys no license or title under any patent, copyright, or mask work right to these products, and makes no representations or warranties that these products are free from patent, copyright, or mask work right infringement, unless otherwise specified.

15. Contact information

For additional information, please visit: <http://www.semiconductors.philips.com>

For sales office addresses, send an email to: sales.addresses@www.semiconductors.philips.com

16. Contents

1	Product profile	1
1.1	General description.	1
1.2	Features	1
1.3	Applications	1
1.4	Quick reference data.	1
2	Pinning information	2
3	Ordering information	2
4	Marking	2
5	Limiting values	2
6	Thermal characteristics	4
7	Characteristics	5
8	Application information	8
9	Package outline	9
10	Packing information	10
11	Revision history	11
12	Data sheet status	12
13	Definitions	12
14	Disclaimers	12
15	Contact information	12



© Koninklijke Philips Electronics N.V. 2004

All rights are reserved. Reproduction in whole or in part is prohibited without the prior written consent of the copyright owner. The information presented in this document does not form part of any quotation or contract, is believed to be accurate and reliable and may be changed without notice. No liability will be accepted by the publisher for any consequence of its use. Publication thereof does not convey nor imply any license under patent- or other industrial or intellectual property rights.

Date of release: 4 October 2004
Document order number: 9397 750 13707

Published in The Netherlands