

PLEASE CHECK WWW.MOLEX.COM FOR LATEST PART INFORMATION

Part Number: [0345760803](#)
Status: **Active**
Overview: [mx123 sealed connection systems](#)
Description: 2.54mm (.100") Pitch, MX123™ Female Receptacle Housing, Keying Option H, Wire Dress Option 0, 56 Circuits, Gray TPA

Documents:

[Drawing \(PDF\)](#) [RoHS Certificate of Compliance \(PDF\)](#)
[Product Specification PS-34566-0000 \(PDF\)](#)

General

Product Family	Crimp Housings
Series	34576
Comments	See Sales Drawing for number of Open Circuits
Overview	mx123 sealed connection systems
Product Name	MX123

Physical

Circuits (maximum)	56
Circuits Detail	56
Color - Resin	Gray
Gender	Female
Glow-Wire Compliant	No
Keying to Mating Part	Yes
Lock to Mating Part	Yes
Material - Resin	Nylon
Number of Rows	4
Packaging Type	Tray
Panel Mount	No
Pitch - Mating Interface (in)	0.100 In
Pitch - Mating Interface (mm)	2.54 mm
Pitch - Term. Interface (in)	0.100 In
Pitch - Term. Interface (mm)	2.54 mm
Polarized to Mating Part	Yes
Stackable	No
Temperature Range - Operating	-40°C to +125°C

Electrical

Current - Maximum per Contact	11A, 25A
-------------------------------	----------

Material Info

Reference - Drawing Numbers

Application Specification	AS-34566-001
Product Specification	PS-34566-0000
Sales Drawing	SD-34576-001



EU RoHS

ELV and RoHS Compliant
REACH SVHC
 Not Reviewed
Halogen-Free
Status
Not Reviewed

China RoHS



Need more information on product environmental compliance?

Email productcompliance@molex.com
 For a multiple part number RoHS Certificate of Compliance, [click here](#)

Please visit the [Contact Us](#) section for any non-product compliance questions.

Search Parts in this Series

[34576Series](#)

Mates With

MX123™ Female Header [31386](#) , [31387](#)

Use With

MX64 Female Terminals [33467](#)

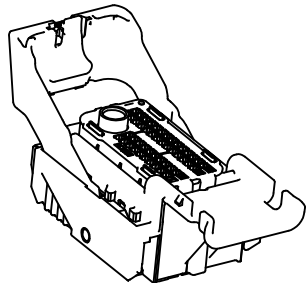

49 CKT
SCALE 1.5:1

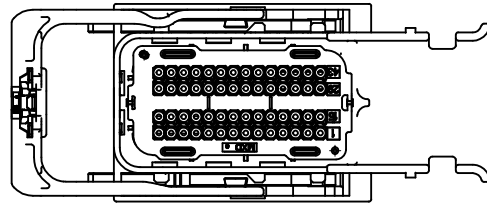

56 CKT
SCALE 1.5:1

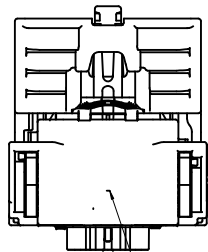

RECOMMENDED LOCATION FOR NOTE 2D

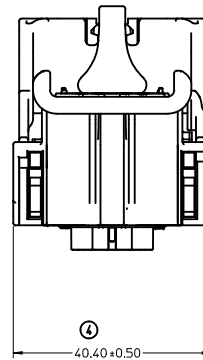
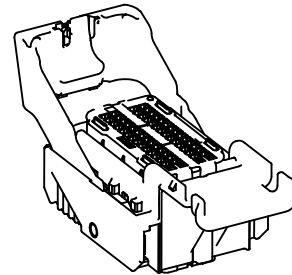
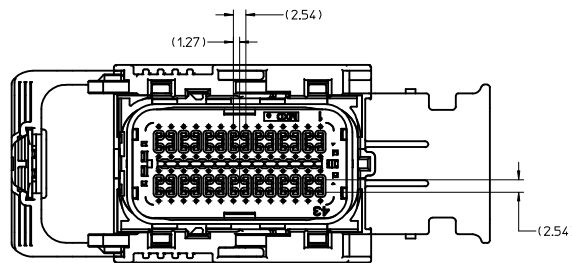
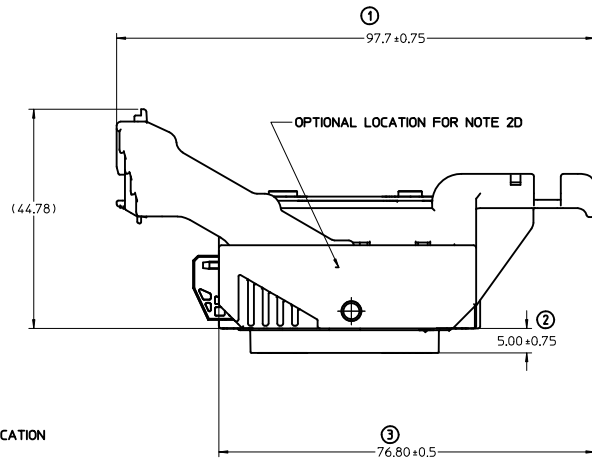

BALLOONS ADDED ① ② ③ ④

NOTES: UNLESS OTHERWISE SPECIFIED

1. MATERIAL:

- A. RESIN: SEE COMPONENT DRAWINGS
- B. COLOR: SEE TABLE

2. DESIGN - GENERAL:

- A. THIS IS A 100% CAD GENERATED PART. THE CAD MATHEMATICAL DATA IS THE MASTER FOR THIS PART. FOR DIMENSIONAL OR ANY INFORMATION NOT SHOWN ON THIS DRAWING, ANALYZE THE CAD MODEL.
- B. TOLERANCES:
 - a. LINEAR: XX ± 0.30, XXX ± 0.10, XXXX ± 0.10
 - b. ANGULAR: X° ± 3.0°
- C. CORNERS SHOWN AS SHARP TO BE R 0.2 MAX.
- D. FOLLOWING PRODUCTION CODES TO BE PERMANENTLY MARKED & HUMAN READABLE TO A LETTER HEIGHT < 3mm.
 - LINE #1: MATERIAL #: XXXXX-XXXX
 - LINE #2: DATE CODE: JJYY (JULIAN DAY, LAST DIGIT OF YEAR)
 - LINE #3: INSPECTION MACHINE CODE + SERIAL #: X_XXXXX
- E-1. PARTS MUST BE FREE OF DISCOLORATION, SALT RESIDUE AND OTHER IMPERFECTIONS THAT AFFECT FIT OR FUNCTION.
- E-2. SCRATCHES OR DENTS NOT TO EXCEED 0.13mm IN DEPTH.
- F. CHANGES IN DESIGN FROM PART PREVIOUSLY APPROVED REQUIRES PRIOR ENGINEERING APPROVAL. THIS INCLUDES BUT IS NOT LIMITED TO DRAFT, MATERIAL OR PROCESSING.
- G. SHALL CONFORM TO THE FOLLOWING PACKAGING SPECIFICATION: PK-31300-019

3. DESIGN - MANUFACTURING:

- A. DRAFT TO BE WITHIN TOLERANCE.
- B. ALLOWABLE FLASH 0.2 MAX HIGH X 0.13 MAX THICK.
- C. ALLOWABLE PARTING LINE MISMATCH 0.2 MAX.
- D. EJECTOR PINS MARK TO BE FLUSH TO 0.25 MAX DEPRESSED.
- E. ALLOWABLE GATE VESTIGE TO BE FLUSH TO 0.25 MAX PROTRUSION.

4. SYSTEM REQUIREMENTS:

- WHEN TESTED TO SAE/USCAR-2 REV: 3, APRIL 2001, AND GMW #3191, AUGUST 22, 2000 (DRAFT).
- A. TPA (WITHOUT TERMINALS)
 - a. INSERTION FORCE FROM PRE-SET TO LOCK: >20
 - b. REMOVAL FORCE FROM PRE-SET: >20
 - B. CPA
 - a. INSERTION FORCE FROM PRE-SET TO LOCK WITH CONNECTOR UN-MATED: >60N
 - b. REMOVAL FORCE FROM PRE-SET: >30N
 - C. GROMMET CAP
 - a. REMOVAL FORCE FROM HOUSING WITH ENGAGED LATCHES: >110N
 - D. MATE ASSIST LEVER
 - a. INADVERTENT ACTUATION FORCE DURING SHIPPING, HANDLING OR PRE-ASSEMBLY: >190N

REV	DESCRIPTION
F15	NEW PIN CONFIGURATION
F14	NEW PIN CONFIGURATION
F13	NEW PIN CONFIGURATION
F12	NEW PIN CONFIGURATION
F11	NEW PIN CONFIGURATION
F10	NEW PIN CONFIGURATION
F9	NEW PIN CONFIGURATION
F8	CORRECTED MATERIAL NUMBER
F7	NEW PIN CONFIGURATION
F6	NEW PIN CONFIGURATION
F5	RELEASE INTO ONE-SPACE FROM PRO-E

ENTER DESCRIPTION DEC NO: UAU2010-1803 DRAWN BY: 2010/06/02 CHKD: TSK IVER APPR: VKOSHY 2010/06/04	QUALITY SYMBOLS ▽=0 ▽=0	GENERAL TOLERANCES (UNLESS SPECIFIED)		DIMENSION STYLE MM ONLY		SCALE 2:1	DESIGN UNITS METRIC	THIRD ANGLE PROJECTION		
		4 PLACES ± --- INCH 3 PLACES ± --- INCH 2 PLACES ± --- INCH 1 PLACE ± --- INCH	4 PLACES ± --- mm 3 PLACES ± --- mm 2 PLACES ± --- mm 1 PLACE ± --- mm	DRAWN BY: SRAJENDRANAT DATE: 2008/02/20	CHECKED BY: TSK IVER DATE: 2008/02/20	TITLE MX123 49/56 CKT HRNS CONN ASSY		MOLEX INCORPORATED		SHEET NO. 1 OF 11
		DRAFT WHERE APPLICABLE MUST REMAIN WITHIN DIMENSIONS		SEE BOM TABLE		MATERIAL NO. SD-34576-001		DOCUMENT NO.		INCORPORATED AND SHOULD NOT BE USED WITHOUT WRITTEN PERMISSION
		F15		D		THIS DRAWING CONTAINS INFORMATION THAT IS PROPRIETARY TO MOLEX		INCORPORATED AND SHOULD NOT BE USED WITHOUT WRITTEN PERMISSION		INCORPORATED AND SHOULD NOT BE USED WITHOUT WRITTEN PERMISSION

WIRE DRESS OPTION 0
HOUSING ONLY, SHOWN FOR CLARITY

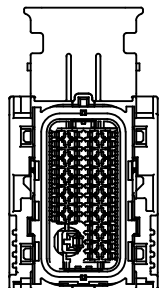

40 OKT
KEY OPTION A

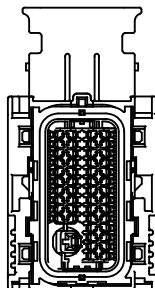

40 OKT
KEY OPTION B

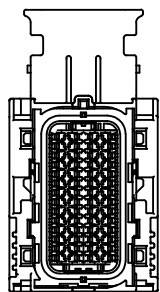

56 OKT
KEY OPTION G

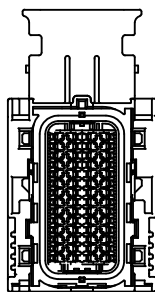

56 OKT
KEY OPTION H

ENTER DESCRIPTION EC NO: UAU2010-1803 DRAWN BY: CHYK/TSK/VER DATE: 2010/06/02 CHECKED BY: APPR:VKOSHY DATE: 2008/02/20 APPROVED BY: 2010/06/04	QUALITY SYMBOLS ▽=0 ▽=0	GENERAL TOLERANCES (UNLESS SPECIFIED) <table border="1"> <tr> <th></th> <th>mm</th> <th>INCH</th> </tr> <tr> <td>4 PLACES</td> <td>±---</td> <td>±---</td> </tr> <tr> <td>3 PLACES</td> <td>±---</td> <td>±---</td> </tr> <tr> <td>2 PLACES</td> <td>±---</td> <td>±---</td> </tr> <tr> <td>1 PLACE</td> <td>±---</td> <td>±---</td> </tr> <tr> <td colspan="3">ANGULAR ±----</td> </tr> </table>		mm	INCH	4 PLACES	±---	±---	3 PLACES	±---	±---	2 PLACES	±---	±---	1 PLACE	±---	±---	ANGULAR ±----			DIMENSION STYLE MM ONLY	SCALE 1.5:1	DESIGN UNITS METRIC	THIRD ANGLE PROJECTION
		mm	INCH																					
	4 PLACES	±---	±---																					
	3 PLACES	±---	±---																					
2 PLACES	±---	±---																						
1 PLACE	±---	±---																						
ANGULAR ±----																								
DRAWN BY: SRAJENDRANAT DATE: 2008/02/20 CHECKED BY: TSK/VER DATE: 2008/02/20 APPROVED BY: VKOSHY DATE: 2008/02/20	TITLE MX123 49/56 CKT HRNS CONN ASSY	MATERIAL NO. MOLEX INCORPORATED		DOCUMENT NO. SD-34576-001	SHEET NO. 2 OF 11																			
DRAFT WHERE APPLICABLE MUST REMAIN WITHIN DIMENSIONS		SEE BOM TABLE		THIS DRAWING CONTAINS INFORMATION THAT IS PROPRIETARY TO MOLEX INCORPORATED AND SHOULD NOT BE USED WITHOUT WRITTEN PERMISSION																				
SIZE D																								

WIRE DRESS OPTION 9
HOUSING ONLY, SHOWN FOR CLARITY

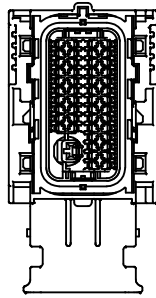

49 OKT
KEY OPTION A

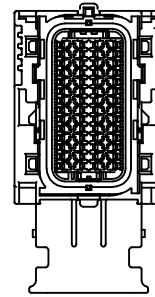

56 OKT
KEY OPTION G

ENTER DESCRIPTION EC NO: UAU2010-1803 DRAWN BY: CHKD:TSK IVER APPR:VKOSHY 2010/06/02 2008/02/20 2010/06/04	QUALITY SYMBOLS ▽=0 ▽=0	GENERAL TOLERANCES (UNLESS SPECIFIED)		DIMENSION STYLE MM ONLY	SCALE 1.5:1	DESIGN UNITS METRIC	THIRD ANGLE PROJECTION		
		4 PLACES ±---+--- 3 PLACES ±---+--- 2 PLACES ±---+--- 1 PLACE ±---+---	mm INCH	DRAWN BY DATE SRAJENDRANAT 2008/02/20	TITLE MX123 49/56 OKT HRNS CONN ASSY				
		DRAFT WHERE APPLICABLE MUST REMAIN WITHIN DIMENSIONS		CHECKED BY DATE TSK IVER 2008/02/20	MOLEX INCORPORATED				
		SEE BOM TABLE		APPROVED BY DATE VKOSHY 2008/02/20	MATERIAL NO. SD-34576-001	DOCUMENT NO.	SHEET NO. 3 OF 11		

WIRE DRESS OPTION 0

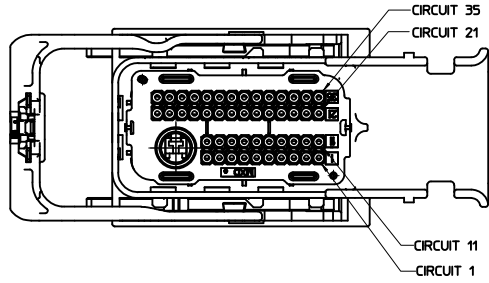

49 CKT

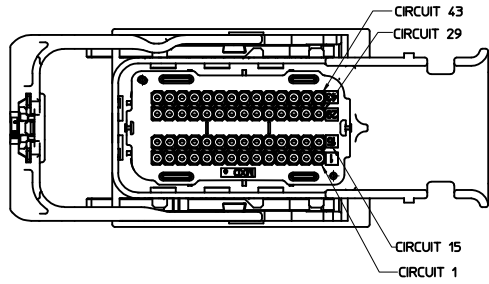

58 CKT

WIRE DRESS OPTION 9

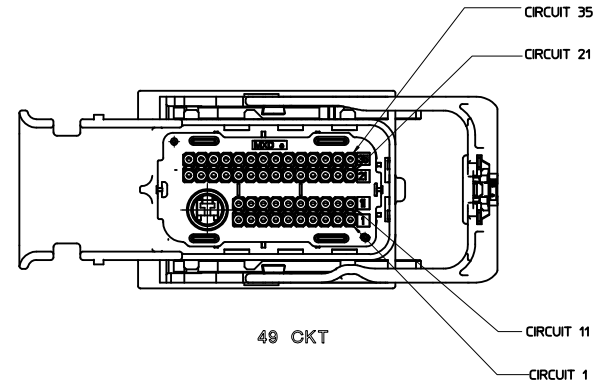

49 CKT

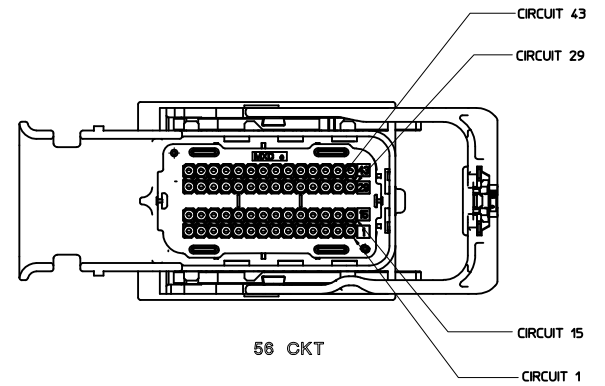

58 CKT

ENTER DESCRIPTION EC NO: UAU2010-1803 DRAWN BY: 2010/06/02 CHKD: TSK IVER APPR: VKOSHY 2010/06/04	QUALITY SYMBOLS	GENERAL TOLERANCES (UNLESS SPECIFIED)	DIMENSION STYLE	SCALE	DESIGN UNITS	THIRD ANGLE PROJECTION
	▽=0 ▽=0	mm INCH 4 PLACES ±---+--- 3 PLACES ±---+--- 2 PLACES ±---+--- 1 PLACE ±---+--- ANGULAR ±---°	MM ONLY	2:1	METRIC	
	DRAWN BY: SRAJENDRANAT CHECKED BY: TSK IVER APPROVED BY: VKOSHY DATE: 2008/02/20 DATE: 2008/02/20 DATE: 2008/02/20	TITLE: MX123 49/56 CKT HRNS CONN ASSY				
	MATERIAL NO. SIZE D	SEE BOM TABLE				MOLEX INCORPORATED DOCUMENT NO. SD-34576-001 SHEET NO. 4 OF 11

STATUS	GM PART #	MATERIAL #	PART/MATERIAL REVISION	WIRE DRESS OPTION	KEY OPTION	COLOR (TPA)	NUMBERS INDICATE CAVITIES OPEN FOR CIRCUITS																			
ACTIVE	TBD	34576-003	F	0	A	BLACK																				
NOT TOOLED	TBD	34576-0203	F	0	B	ST GRY	48	47	46	45	44	43	42	41	40	39	38	37	36	35						
NOT TOOLED	TBD	34576-0303	F	0	C	BLUE	34	33	32	31	30	29	28	27	26	25	24	23	22	21						
NOT TOOLED	TBD	34576-0403	F	0	D	BROWN	49										20	19	18	17	16	15	14	13	12	11
NOT TOOLED	TBD	34576-0503	F	0	E	GREEN											10	9	8	7	6	5	4	3	2	1
NOT TOOLED	TBD	34576-0603	F	0	F	NATURAL																				
AVAILABLE	12582680	34576-0703	F	0	G	BLUE																				
ACTIVE	12582681	34576-0803	F	0	H	ST GRY	56	55	54	53	52	51	50	49	48	47	46	45	44	43						
ACTIVE	TBD	34576-0903	F	0	J	BLACK	42	41	40	39	38	37	36	35	34	33	32	31	30	29						
ACTIVE	TBD	34576-1003	F	0	K	BROWN	28	27	26	25	24	23	22	21	20	19	18	17	16	15						
ACTIVE	TBD	34576-1103	F	0	L	GREEN	14	13	12	11	10	9	8	7	6	5	4	3	2	1						
ACTIVE	TBD	34576-1203	F	0	M	NATURAL																				
ACTIVE	TBD	34576-1303	F	9	A	BLACK																				
NOT TOOLED	TBD	34576-1403	F	9	B	ST GRY	48	47	46	45	44	43	42	41	40	39	38	37	36	35						
NOT TOOLED	TBD	34576-1503	F	9	C	BLUE	34	33	32	31	30	29	28	27	26	25	24	23	22	21						
NOT TOOLED	TBD	34576-1603	F	9	D	BROWN	49										20	19	18	17	16	15	14	13	12	11
NOT TOOLED	TBD	34576-1703	F	9	E	GREEN											10	9	8	7	6	5	4	3	2	1
NOT TOOLED	TBD	34576-1803	F	9	F	NATURAL																				
ACTIVE	12603600	34576-1903	F	9	G	BLUE																				
ACTIVE	12603601	34576-2003	F	9	H	ST GRY	56	55	54	53	52	51	50	49	48	47	46	45	44	43						
ACTIVE	TBD	34576-2103	F	9	J	BLACK	42	41	40	39	38	37	36	35	34	33	32	31	30	29						
ACTIVE	TBD	34576-2203	F	9	K	BROWN	28	27	26	25	24	23	22	21	20	19	18	17	16	15						
ACTIVE	TBD	34576-2303	F	9	L	GREEN	14	13	12	11	10	9	8	7	6	5	4	3	2	1						
ACTIVE	TBD	34576-2403	F	9	M	NATURAL																				
AVAILABLE	NOT APPLICABLE	34576-2503	F	0	G	BLUE	56	55	54	53				49	48	47			44							
									40				37	36	35	34	33									
																20	19	18								
							13	12				9		7	6					2						
AVAILABLE	NOT APPLICABLE	34576-2603	F	0	G	BLUE	56	55	54	53				49	48	47			44							
									40				37	36	35	34	33									
																20	19	18								
							13	12				9		7	6											
AVAILABLE	NOT APPLICABLE	34576-2703	F	0	G	BLUE																				

SEE NEXT PAGE FOR ADDITIONAL NUMBERS

ENTER DESCRIPTION EC NO: UAU2010-1803 DRAWN BY: 2010/06/02 CHKD: TSK IVER APPR: VKOSHY 2010/06/04	QUALITY SYMBOLS	GENERAL TOLERANCES (UNLESS SPECIFIED)	DIMENSION STYLE	SCALE	DESIGN UNITS	THIRD ANGLE PROJECTION
	$\nabla=0$ $\nabla=0$	mm INCH 4 PLACES ±--- ±--- 3 PLACES ±--- ±--- 2 PLACES ±--- ±--- 1 PLACE ±--- ±---	MM ONLY		METRIC	
		DRAFT WHERE APPLICABLE MUST REMAIN WITHIN DIMENSIONS	DRAWN BY: SRAJENDRANAT CHECKED BY: TSK IVER APPROVED BY: VKOSHY DATE: 2008/02/20	DATE: 2008/02/20	TITLE: MX123 49/56 CKT HRNS CONN ASSY	MOLEX INCORPORATED
			SEE BOM TABLE	MATERIAL NO. SD-34576-001	SHEET NO. 5 OF 11	THIS DRAWING CONTAINS INFORMATION THAT IS PROPRIETARY TO MOLEX INCORPORATED AND SHOULD NOT BE USED WITHOUT WRITTEN PERMISSION

20 19 18 17 16 15 14 13 12 11 10 9 8 7 6 5 4 3 2 1

STATUS	GM PART #	MATERIAL #	PART/MATERIAL REVISION	WIRE DRESS OPTION	KEY OPTION	COLOR (TPA)	NUMBERS INDICATE CAVITIES OPEN FOR CIRCUITS																																												
AVAILABLE	NOT APPLICABLE	34576-2803	F	0	G	BLUE	<table border="1"> <tr><td>55</td><td>54</td><td>53</td><td>51</td><td>49</td><td>48</td><td>47</td><td>44</td></tr> <tr><td>40</td><td></td><td></td><td>37</td><td>36</td><td>35</td><td>34</td><td>33</td></tr> <tr><td>26</td><td></td><td></td><td></td><td></td><td></td><td>20</td><td>19</td></tr> <tr><td>13</td><td>12</td><td></td><td>9</td><td>7</td><td></td><td></td><td></td></tr> </table>	55	54	53	51	49	48	47	44	40			37	36	35	34	33	26						20	19	13	12		9	7															
55	54	53	51	49	48	47	44																																												
40			37	36	35	34	33																																												
26						20	19																																												
13	12		9	7																																															
AVAILABLE	NOT APPLICABLE	34576-2903	F	0	G	BLUE	<table border="1"> <tr><td>56</td><td>55</td><td>53</td><td></td><td>49</td><td>48</td><td>47</td><td>46</td><td>45</td><td>44</td></tr> <tr><td></td><td>40</td><td>39</td><td>37</td><td>36</td><td>35</td><td>34</td><td>33</td><td></td><td>30</td></tr> <tr><td></td><td></td><td>25</td><td></td><td></td><td></td><td>20</td><td>19</td><td>18</td><td></td></tr> <tr><td>13</td><td>12</td><td></td><td>9</td><td>7</td><td></td><td></td><td></td><td></td><td></td></tr> </table>	56	55	53		49	48	47	46	45	44		40	39	37	36	35	34	33		30			25				20	19	18		13	12		9	7									
56	55	53		49	48	47	46	45	44																																										
	40	39	37	36	35	34	33		30																																										
		25				20	19	18																																											
13	12		9	7																																															
AVAILABLE	NOT APPLICABLE	34576-3003	F	0	G	BLUE	<table border="1"> <tr><td>56</td><td>55</td><td>54</td><td>53</td><td></td><td>49</td><td>48</td><td>47</td><td>44</td><td></td></tr> <tr><td></td><td>40</td><td></td><td></td><td>37</td><td>36</td><td>35</td><td>34</td><td>33</td><td>29</td></tr> <tr><td></td><td></td><td></td><td></td><td></td><td></td><td></td><td>20</td><td>19</td><td>18</td></tr> <tr><td>13</td><td>12</td><td></td><td>9</td><td>7</td><td>6</td><td></td><td></td><td></td><td>2</td></tr> </table>	56	55	54	53		49	48	47	44			40			37	36	35	34	33	29								20	19	18	13	12		9	7	6				2				
56	55	54	53		49	48	47	44																																											
	40			37	36	35	34	33	29																																										
							20	19	18																																										
13	12		9	7	6				2																																										
AVAILABLE	NOT APPLICABLE	34576-3103	F	0	G	BLUE	<table border="1"> <tr><td>56</td><td>55</td><td>54</td><td>53</td><td></td><td>49</td><td>48</td><td>47</td><td>46</td><td>45</td><td>44</td></tr> <tr><td></td><td>40</td><td>39</td><td>37</td><td>36</td><td>35</td><td>34</td><td>33</td><td></td><td></td><td></td></tr> <tr><td></td><td></td><td></td><td></td><td></td><td></td><td>20</td><td>19</td><td>18</td><td></td><td></td></tr> <tr><td>13</td><td>12</td><td></td><td>9</td><td>7</td><td></td><td></td><td></td><td></td><td></td><td></td></tr> </table>	56	55	54	53		49	48	47	46	45	44		40	39	37	36	35	34	33										20	19	18			13	12		9	7						
56	55	54	53		49	48	47	46	45	44																																									
	40	39	37	36	35	34	33																																												
						20	19	18																																											
13	12		9	7																																															
AVAILABLE	NOT APPLICABLE	34576-3203	F	0	G	BLUE	<table border="1"> <tr><td>55</td><td>54</td><td>53</td><td></td><td>49</td><td>48</td><td>47</td><td>46</td><td>44</td><td></td></tr> <tr><td></td><td>40</td><td></td><td></td><td>37</td><td>36</td><td>35</td><td>34</td><td>33</td><td>32</td><td>31</td></tr> <tr><td></td><td>26</td><td></td><td></td><td></td><td></td><td></td><td>20</td><td>19</td><td>18</td><td></td></tr> <tr><td>13</td><td>12</td><td></td><td>9</td><td>7</td><td></td><td></td><td></td><td></td><td></td><td></td></tr> </table>	55	54	53		49	48	47	46	44			40			37	36	35	34	33	32	31		26						20	19	18		13	12		9	7							
55	54	53		49	48	47	46	44																																											
	40			37	36	35	34	33	32	31																																									
	26						20	19	18																																										
13	12		9	7																																															
AVAILABLE	NOT APPLICABLE	34576-3303	F	0	G	BLUE	<table border="1"> <tr><td>56</td><td>55</td><td>54</td><td></td><td></td><td>49</td><td>48</td><td>47</td><td></td><td>44</td></tr> <tr><td></td><td>40</td><td></td><td></td><td>37</td><td>36</td><td>35</td><td>34</td><td>33</td><td></td></tr> <tr><td></td><td></td><td></td><td></td><td></td><td></td><td></td><td>20</td><td>19</td><td>18</td></tr> <tr><td>13</td><td>12</td><td></td><td>9</td><td>7</td><td>6</td><td></td><td></td><td></td><td></td></tr> </table>	56	55	54			49	48	47		44		40			37	36	35	34	33									20	19	18	13	12		9	7	6								
56	55	54			49	48	47		44																																										
	40			37	36	35	34	33																																											
							20	19	18																																										
13	12		9	7	6																																														
AVAILABLE	NOT APPLICABLE	34576-3403	F	0	G	BLUE	<table border="1"> <tr><td>55</td><td>54</td><td>53</td><td></td><td>49</td><td>48</td><td>47</td><td>44</td><td></td></tr> <tr><td></td><td>40</td><td>39</td><td>37</td><td>36</td><td>35</td><td>34</td><td>33</td><td></td></tr> <tr><td></td><td>26</td><td></td><td></td><td></td><td></td><td></td><td>20</td><td>19</td><td>18</td></tr> <tr><td>13</td><td>12</td><td></td><td>9</td><td>7</td><td></td><td></td><td></td><td></td><td></td></tr> </table>	55	54	53		49	48	47	44			40	39	37	36	35	34	33			26						20	19	18	13	12		9	7											
55	54	53		49	48	47	44																																												
	40	39	37	36	35	34	33																																												
	26						20	19	18																																										
13	12		9	7																																															
AVAILABLE	NOT APPLICABLE	34576-3503	F	0	G	BLUE	<table border="1"> <tr><td>56</td><td>55</td><td>53</td><td></td><td>49</td><td>48</td><td>47</td><td>44</td><td></td></tr> <tr><td></td><td>40</td><td></td><td></td><td>37</td><td>36</td><td>35</td><td>34</td><td>33</td><td></td></tr> <tr><td></td><td></td><td></td><td></td><td></td><td></td><td></td><td>20</td><td>19</td><td>18</td></tr> <tr><td>13</td><td>12</td><td></td><td>9</td><td>7</td><td>6</td><td></td><td></td><td></td><td>2</td></tr> </table>	56	55	53		49	48	47	44			40			37	36	35	34	33									20	19	18	13	12		9	7	6				2					
56	55	53		49	48	47	44																																												
	40			37	36	35	34	33																																											
							20	19	18																																										
13	12		9	7	6				2																																										

SEE NEXT PAGE FOR ADDITIONAL NUMBERS

ENTER DESCRIPTION EC NO: UAU2010-1803 DRAWN BY: DRWNAH001 CHKD: TSK IVER APPR: VKOSHY DATE: 2010/06/02 DATE: 2008/02/20 DATE: 2010/06/04	QUALITY SYMBOLS ▽=0 ▽=0	GENERAL TOLERANCES (UNLESS SPECIFIED) <table border="1"> <tr><th></th><th>mm</th><th>INCH</th></tr> <tr><td>4 PLACES</td><td>±----</td><td>±----</td></tr> <tr><td>3 PLACES</td><td>±----</td><td>±----</td></tr> <tr><td>2 PLACES</td><td>±----</td><td>±----</td></tr> <tr><td>1 PLACE</td><td>±----</td><td>±----</td></tr> </table>		mm	INCH	4 PLACES	±----	±----	3 PLACES	±----	±----	2 PLACES	±----	±----	1 PLACE	±----	±----	DIMENSION STYLE MM ONLY	SCALE SCALE	DESIGN UNITS METRIC	THIRD ANGLE PROJECTION
		mm	INCH																		
	4 PLACES	±----	±----																		
	3 PLACES	±----	±----																		
2 PLACES	±----	±----																			
1 PLACE	±----	±----																			
APPROVED BY VKOSHY DATE: 2008/02/20	DRAWN BY SRAJENDRANAT DATE: 2008/02/20	CHECKED BY TSK IVER DATE: 2008/02/20	TITLE MX123 49/56 CKT HRNS CONN ASSY	MOLEX INCORPORATED																	
DRAFT WHERE APPLICABLE MUST REMAIN WITHIN DIMENSIONS	SEE BOM TABLE	MATERIAL NO. SD-34576-001	DOCUMENT NO. SD-34576-001	SHEET NO. 6 OF 11	THIS DRAWING CONTAINS INFORMATION THAT IS PROPRIETARY TO MOLEX INCORPORATED AND SHOULD NOT BE USED WITHOUT WRITTEN PERMISSION																
SIZE D																					

19 18 17 16 15 14 13 12 11 10 9 8 7 6 5 4 3 2 1

20 19 18 17 16 15 14 13 12 11 10 9 8 7 6 5 4 3 2 1

STATUS	GM PART #	MATERIAL #	PART/MATERIAL REVISION	WIRE DRESS OPTION	KEY OPTION	COLOR (TPA)	NUMBERS INDICATE CAVITIES OPEN FOR CIRCUITS																																																												
AVAILABLE	NOT APPLICABLE	34576-3603	F	0	G	BLUE	<table border="1"> <tr><td>55</td><td>54</td><td>53</td><td></td><td></td><td>49</td><td>48</td><td>47</td><td></td><td>44</td></tr> <tr><td>40</td><td></td><td></td><td>37</td><td>36</td><td>35</td><td>34</td><td>33</td><td></td><td></td></tr> <tr><td>26</td><td></td><td></td><td></td><td></td><td></td><td>20</td><td>19</td><td>18</td><td></td></tr> <tr><td>13</td><td>12</td><td></td><td>9</td><td>7</td><td></td><td></td><td></td><td></td><td></td></tr> </table>	55	54	53			49	48	47		44	40			37	36	35	34	33			26						20	19	18		13	12		9	7																									
55	54	53			49	48	47		44																																																										
40			37	36	35	34	33																																																												
26						20	19	18																																																											
13	12		9	7																																																															
AVAILABLE	NOT APPLICABLE	34576-3703	F	0	G	BLUE	<table border="1"> <tr><td>56</td><td>55</td><td>54</td><td>53</td><td>51</td><td>49</td><td>48</td><td>47</td><td></td><td>44</td></tr> <tr><td></td><td>40</td><td></td><td></td><td>37</td><td>36</td><td>35</td><td>34</td><td>33</td><td>29</td></tr> <tr><td></td><td></td><td></td><td></td><td></td><td></td><td></td><td>20</td><td>19</td><td>18</td></tr> <tr><td>13</td><td>12</td><td></td><td>9</td><td>7</td><td>6</td><td></td><td></td><td></td><td>16</td></tr> <tr><td></td><td></td><td></td><td></td><td></td><td></td><td></td><td></td><td></td><td>15</td></tr> <tr><td></td><td></td><td></td><td></td><td></td><td></td><td></td><td></td><td></td><td>2</td></tr> </table>	56	55	54	53	51	49	48	47		44		40			37	36	35	34	33	29								20	19	18	13	12		9	7	6				16										15										2
56	55	54	53	51	49	48	47		44																																																										
	40			37	36	35	34	33	29																																																										
							20	19	18																																																										
13	12		9	7	6				16																																																										
									15																																																										
									2																																																										
AVAILABLE	NOT APPLICABLE	34576-3803	F	0	G	BLUE	<table border="1"> <tr><td>56</td><td>54</td><td>53</td><td></td><td></td><td>49</td><td>47</td><td>46</td><td>44</td><td></td></tr> <tr><td></td><td>40</td><td>39</td><td>37</td><td>36</td><td>35</td><td>33</td><td>32</td><td>31</td><td>29</td></tr> <tr><td></td><td></td><td>25</td><td></td><td></td><td></td><td>20</td><td>19</td><td>18</td><td>15</td></tr> <tr><td>13</td><td>12</td><td></td><td>9</td><td>7</td><td></td><td></td><td></td><td></td><td>2</td></tr> </table>	56	54	53			49	47	46	44			40	39	37	36	35	33	32	31	29			25				20	19	18	15	13	12		9	7					2																				
56	54	53			49	47	46	44																																																											
	40	39	37	36	35	33	32	31	29																																																										
		25				20	19	18	15																																																										
13	12		9	7					2																																																										
AVAILABLE	NOT APPLICABLE	34576-3903	F	0	G	BLUE	<table border="1"> <tr><td>56</td><td>54</td><td>53</td><td></td><td></td><td>49</td><td>47</td><td></td><td>44</td><td></td></tr> <tr><td></td><td>40</td><td>39</td><td>37</td><td>36</td><td>35</td><td>33</td><td></td><td></td><td>29</td></tr> <tr><td></td><td></td><td>25</td><td></td><td></td><td></td><td>20</td><td>19</td><td>18</td><td>15</td></tr> <tr><td>13</td><td>12</td><td></td><td>9</td><td>7</td><td></td><td></td><td></td><td></td><td></td></tr> </table>	56	54	53			49	47		44			40	39	37	36	35	33			29			25				20	19	18	15	13	12		9	7																									
56	54	53			49	47		44																																																											
	40	39	37	36	35	33			29																																																										
		25				20	19	18	15																																																										
13	12		9	7																																																															
AVAILABLE	NOT APPLICABLE	34576-4003	F	0	G	BLUE	<table border="1"> <tr><td>56</td><td>55</td><td>54</td><td>53</td><td></td><td>49</td><td>48</td><td>47</td><td>45</td><td>44</td></tr> <tr><td></td><td>40</td><td>39</td><td>37</td><td>36</td><td>35</td><td>34</td><td>33</td><td></td><td>29</td></tr> <tr><td></td><td></td><td>25</td><td></td><td></td><td></td><td>20</td><td>19</td><td>18</td><td>16</td></tr> <tr><td>13</td><td>12</td><td></td><td>9</td><td>7</td><td>6</td><td></td><td></td><td></td><td>15</td></tr> <tr><td></td><td></td><td></td><td></td><td></td><td></td><td></td><td></td><td></td><td>1</td></tr> </table>	56	55	54	53		49	48	47	45	44		40	39	37	36	35	34	33		29			25				20	19	18	16	13	12		9	7	6				15										1										
56	55	54	53		49	48	47	45	44																																																										
	40	39	37	36	35	34	33		29																																																										
		25				20	19	18	16																																																										
13	12		9	7	6				15																																																										
									1																																																										
AVAILABLE	NOT APPLICABLE	34576-4103	F	0	G	BLUE	<table border="1"> <tr><td>56</td><td>55</td><td>54</td><td>53</td><td></td><td>49</td><td>48</td><td>47</td><td>46</td><td>44</td></tr> <tr><td></td><td>40</td><td>39</td><td>38</td><td>37</td><td>36</td><td>35</td><td>34</td><td>33</td><td>31</td></tr> <tr><td></td><td></td><td>25</td><td></td><td></td><td></td><td>20</td><td>19</td><td>18</td><td>16</td></tr> <tr><td>13</td><td>12</td><td></td><td>9</td><td>7</td><td></td><td></td><td></td><td></td><td></td></tr> </table>	56	55	54	53		49	48	47	46	44		40	39	38	37	36	35	34	33	31			25				20	19	18	16	13	12		9	7																									
56	55	54	53		49	48	47	46	44																																																										
	40	39	38	37	36	35	34	33	31																																																										
		25				20	19	18	16																																																										
13	12		9	7																																																															
AVAILABLE	NOT APPLICABLE	34576-4203	F	0	G	BLUE	<table border="1"> <tr><td>56</td><td>55</td><td>54</td><td>53</td><td></td><td>49</td><td>48</td><td>47</td><td>45</td><td>44</td></tr> <tr><td></td><td>40</td><td>39</td><td>37</td><td>36</td><td>35</td><td>34</td><td>33</td><td></td><td></td></tr> <tr><td></td><td></td><td></td><td></td><td></td><td></td><td>20</td><td>19</td><td>18</td><td></td></tr> <tr><td>13</td><td>12</td><td></td><td>9</td><td>7</td><td></td><td></td><td></td><td></td><td></td></tr> </table>	56	55	54	53		49	48	47	45	44		40	39	37	36	35	34	33									20	19	18		13	12		9	7																									
56	55	54	53		49	48	47	45	44																																																										
	40	39	37	36	35	34	33																																																												
						20	19	18																																																											
13	12		9	7																																																															
AVAILABLE	NOT APPLICABLE	34576-4303	F	0	G	BLUE	<table border="1"> <tr><td>56</td><td>55</td><td>54</td><td>53</td><td>51</td><td>49</td><td>48</td><td>47</td><td>45</td><td>44</td></tr> <tr><td>41</td><td>40</td><td>38</td><td>37</td><td>36</td><td>35</td><td>34</td><td>33</td><td></td><td>30</td></tr> <tr><td></td><td>26</td><td>25</td><td>24</td><td>22</td><td>21</td><td>20</td><td>19</td><td>17</td><td></td></tr> <tr><td>13</td><td>12</td><td></td><td>9</td><td>7</td><td></td><td></td><td></td><td>4</td><td>3</td></tr> <tr><td></td><td></td><td></td><td></td><td></td><td></td><td></td><td></td><td></td><td>1</td></tr> </table>	56	55	54	53	51	49	48	47	45	44	41	40	38	37	36	35	34	33		30		26	25	24	22	21	20	19	17		13	12		9	7				4	3										1										
56	55	54	53	51	49	48	47	45	44																																																										
41	40	38	37	36	35	34	33		30																																																										
	26	25	24	22	21	20	19	17																																																											
13	12		9	7				4	3																																																										
									1																																																										

SEE NEXT PAGE FOR ADDITIONAL NUMBERS

ENTER DESCRIPTION EC NO: UAU2010-1803 DRAWN BY: DRWNAH01 CHKD: TSK IVER APPR: VKOSHY 2010/06/02 2008/02/20 2010/06/04	QUALITY SYMBOLS	GENERAL TOLERANCES (UNLESS SPECIFIED)	DIMENSION STYLE	SCALE	DESIGN UNITS	THIRD ANGLE PROJECTION																							
	$\nabla=0$ $\nabla=0$	<table border="1"> <tr><th></th><th>mm</th><th>INCH</th></tr> <tr><td>4 PLACES</td><td>±----</td><td>±----</td></tr> <tr><td>3 PLACES</td><td>±---</td><td>±---</td></tr> <tr><td>2 PLACES</td><td>±--</td><td>±--</td></tr> <tr><td>1 PLACE</td><td>±-</td><td>±-</td></tr> </table>		mm	INCH	4 PLACES	±----	±----	3 PLACES	±---	±---	2 PLACES	±--	±--	1 PLACE	±-	±-	MM ONLY	SCALE	METRIC									
		mm	INCH																										
	4 PLACES	±----	±----																										
3 PLACES	±---	±---																											
2 PLACES	±--	±--																											
1 PLACE	±-	±-																											
<table border="1"> <tr><td>4 PLACES</td><td>±----</td><td>±----</td></tr> <tr><td>3 PLACES</td><td>±---</td><td>±---</td></tr> <tr><td>2 PLACES</td><td>±--</td><td>±--</td></tr> <tr><td>1 PLACE</td><td>±-</td><td>±-</td></tr> </table>	4 PLACES	±----	±----	3 PLACES	±---	±---	2 PLACES	±--	±--	1 PLACE	±-	±-	<table border="1"> <tr><td>4 PLACES</td><td>±----</td><td>±----</td></tr> <tr><td>3 PLACES</td><td>±---</td><td>±---</td></tr> <tr><td>2 PLACES</td><td>±--</td><td>±--</td></tr> <tr><td>1 PLACE</td><td>±-</td><td>±-</td></tr> </table>	4 PLACES	±----	±----	3 PLACES	±---	±---	2 PLACES	±--	±--	1 PLACE	±-	±-	DRAWN BY: SRAJENDRANAT CHECKED BY: TSK IVER APPROVED BY: VKOSHY DATE: 2008/02/20 DATE: 2008/02/20 DATE: 2008/02/20	TITLE: MX123 49/56 CKT HRNS CONN ASSY		MOLEX INCORPORATED
4 PLACES	±----	±----																											
3 PLACES	±---	±---																											
2 PLACES	±--	±--																											
1 PLACE	±-	±-																											
4 PLACES	±----	±----																											
3 PLACES	±---	±---																											
2 PLACES	±--	±--																											
1 PLACE	±-	±-																											
DRAFT WHERE APPLICABLE MUST REMAIN WITHIN DIMENSIONS	SEE BOM TABLE	MATERIAL NO. SD-34576-001	SHEET NO. 7 OF 11																										

19 18 17 16 15 14 13 12 11 10 9 8 7 6 5 4 3 2 1

20 19 18 17 16 15 14 13 12 11 10 9 8 7 6 5 4 3 2 1

STATUS	GM PART #	MATERIAL #	PART/MATERIAL REVISION	WIRE DRESS OPTION	KEY OPTION	COLOR (TPA)	NUMBERS INDICATE CAVITIES OPEN FOR CIRCUITS																																																
AVAILABLE	NOT APPLICABLE	34576-4403	F	0	G	BLUE	<table border="1"> <tr><td>56</td><td>55</td><td>54</td><td>53</td><td></td><td></td><td>49</td><td>48</td><td>47</td><td>46</td><td>44</td><td></td></tr> <tr><td></td><td></td><td>40</td><td>39</td><td>37</td><td>36</td><td>35</td><td>34</td><td>33</td><td>32</td><td>31</td><td>29</td></tr> <tr><td></td><td></td><td></td><td>25</td><td></td><td></td><td></td><td></td><td></td><td>20</td><td>19</td><td>18</td></tr> <tr><td></td><td></td><td></td><td>12</td><td></td><td></td><td>9</td><td>7</td><td></td><td></td><td></td><td>16</td></tr> </table>	56	55	54	53			49	48	47	46	44				40	39	37	36	35	34	33	32	31	29				25						20	19	18				12			9	7				16
56	55	54	53			49	48	47	46	44																																													
		40	39	37	36	35	34	33	32	31	29																																												
			25						20	19	18																																												
			12			9	7				16																																												
AVAILABLE	NOT APPLICABLE	34576-4503	F	0	G	BLUE	<table border="1"> <tr><td>56</td><td>55</td><td>54</td><td>53</td><td></td><td></td><td>49</td><td>48</td><td>47</td><td>46</td><td>44</td><td></td></tr> <tr><td></td><td></td><td>40</td><td>39</td><td>37</td><td>36</td><td>35</td><td>34</td><td>33</td><td>32</td><td>31</td><td>30</td></tr> <tr><td></td><td></td><td></td><td>25</td><td>24</td><td></td><td></td><td>22</td><td>21</td><td>20</td><td>19</td><td>18</td></tr> <tr><td></td><td></td><td></td><td>13</td><td>12</td><td></td><td>9</td><td>7</td><td></td><td>4</td><td></td><td>2</td></tr> </table>	56	55	54	53			49	48	47	46	44				40	39	37	36	35	34	33	32	31	30				25	24			22	21	20	19	18				13	12		9	7		4		2
56	55	54	53			49	48	47	46	44																																													
		40	39	37	36	35	34	33	32	31	30																																												
			25	24			22	21	20	19	18																																												
			13	12		9	7		4		2																																												
AVAILABLE	NOT APPLICABLE	34576-4603	F	0	G	BLUE	<table border="1"> <tr><td>56</td><td>55</td><td>54</td><td>53</td><td></td><td></td><td>49</td><td>48</td><td>47</td><td>46</td><td>44</td><td></td></tr> <tr><td></td><td></td><td>40</td><td>39</td><td>37</td><td>36</td><td>35</td><td>34</td><td>33</td><td>32</td><td>31</td><td>29</td></tr> <tr><td></td><td></td><td></td><td>25</td><td></td><td></td><td></td><td></td><td>20</td><td>19</td><td>18</td><td>16</td></tr> <tr><td></td><td></td><td></td><td>13</td><td>12</td><td></td><td>9</td><td>7</td><td></td><td></td><td></td><td>16</td></tr> </table>	56	55	54	53			49	48	47	46	44				40	39	37	36	35	34	33	32	31	29				25					20	19	18	16				13	12		9	7				16
56	55	54	53			49	48	47	46	44																																													
		40	39	37	36	35	34	33	32	31	29																																												
			25					20	19	18	16																																												
			13	12		9	7				16																																												
AVAILABLE	NOT APPLICABLE	34576-4703	F	0	G	BLUE	<table border="1"> <tr><td>56</td><td>55</td><td>54</td><td>53</td><td>51</td><td></td><td>49</td><td>48</td><td>47</td><td></td><td>44</td><td></td></tr> <tr><td></td><td></td><td>40</td><td>39</td><td>37</td><td>36</td><td>35</td><td>34</td><td>33</td><td></td><td>30</td><td></td></tr> <tr><td></td><td></td><td></td><td>25</td><td></td><td></td><td>22</td><td>21</td><td>20</td><td>19</td><td>18</td><td>16</td></tr> <tr><td></td><td></td><td></td><td>13</td><td>12</td><td></td><td>9</td><td>7</td><td></td><td>4</td><td></td><td>2</td></tr> </table>	56	55	54	53	51		49	48	47		44				40	39	37	36	35	34	33		30					25			22	21	20	19	18	16				13	12		9	7		4		2
56	55	54	53	51		49	48	47		44																																													
		40	39	37	36	35	34	33		30																																													
			25			22	21	20	19	18	16																																												
			13	12		9	7		4		2																																												
AVAILABLE	NOT APPLICABLE	34576-4803	F	0	G	BLUE	<table border="1"> <tr><td></td><td>55</td><td></td><td>53</td><td>51</td><td></td><td>49</td><td>48</td><td>47</td><td></td><td>44</td><td></td></tr> <tr><td></td><td></td><td>40</td><td>39</td><td>37</td><td>36</td><td>35</td><td>34</td><td>33</td><td></td><td>30</td><td></td></tr> <tr><td></td><td></td><td></td><td>26</td><td></td><td></td><td></td><td></td><td>20</td><td>19</td><td>18</td><td>16</td></tr> <tr><td></td><td></td><td></td><td>13</td><td>12</td><td></td><td>9</td><td>7</td><td></td><td>4</td><td></td><td>2</td></tr> </table>		55		53	51		49	48	47		44				40	39	37	36	35	34	33		30					26					20	19	18	16				13	12		9	7		4		2
	55		53	51		49	48	47		44																																													
		40	39	37	36	35	34	33		30																																													
			26					20	19	18	16																																												
			13	12		9	7		4		2																																												
ACTIVE	NOT APPLICABLE	34576-4903	F	9	G	BLUE	<table border="1"> <tr><td></td><td>55</td><td>54</td><td>53</td><td></td><td></td><td>49</td><td>48</td><td>47</td><td>46</td><td>44</td><td></td></tr> <tr><td></td><td></td><td>40</td><td></td><td>37</td><td>36</td><td>35</td><td>34</td><td>33</td><td>32</td><td>31</td><td></td></tr> <tr><td></td><td></td><td></td><td>26</td><td></td><td></td><td></td><td></td><td>20</td><td>19</td><td>18</td><td></td></tr> <tr><td></td><td></td><td></td><td>13</td><td>12</td><td></td><td>9</td><td>7</td><td></td><td></td><td></td><td></td></tr> </table>		55	54	53			49	48	47	46	44				40		37	36	35	34	33	32	31					26					20	19	18					13	12		9	7				
	55	54	53			49	48	47	46	44																																													
		40		37	36	35	34	33	32	31																																													
			26					20	19	18																																													
			13	12		9	7																																																
AVAILABLE	NOT APPLICABLE	34576-5003	F	0	G	BLUE	<table border="1"> <tr><td></td><td>55</td><td>54</td><td>53</td><td></td><td></td><td>49</td><td>48</td><td>47</td><td>45</td><td>44</td><td></td></tr> <tr><td></td><td></td><td>40</td><td></td><td>37</td><td>36</td><td>35</td><td>34</td><td>33</td><td></td><td></td><td></td></tr> <tr><td></td><td></td><td></td><td>26</td><td></td><td></td><td></td><td></td><td>20</td><td>19</td><td>18</td><td></td></tr> <tr><td></td><td></td><td></td><td>13</td><td>12</td><td></td><td>9</td><td>7</td><td></td><td></td><td></td><td></td></tr> </table>		55	54	53			49	48	47	45	44				40		37	36	35	34	33							26					20	19	18					13	12		9	7				
	55	54	53			49	48	47	45	44																																													
		40		37	36	35	34	33																																															
			26					20	19	18																																													
			13	12		9	7																																																
AVAILABLE	NOT APPLICABLE	34576-5103	F	0	G	BLUE	<table border="1"> <tr><td></td><td>55</td><td></td><td>53</td><td>51</td><td></td><td>49</td><td>48</td><td>47</td><td></td><td>44</td><td></td></tr> <tr><td></td><td></td><td>40</td><td></td><td>37</td><td>36</td><td>35</td><td>34</td><td>33</td><td></td><td>30</td><td></td></tr> <tr><td></td><td></td><td></td><td>26</td><td></td><td>24</td><td></td><td></td><td>20</td><td>19</td><td>18</td><td>16</td></tr> <tr><td></td><td></td><td></td><td>13</td><td>12</td><td></td><td>9</td><td>7</td><td></td><td>4</td><td></td><td>2</td></tr> </table>		55		53	51		49	48	47		44				40		37	36	35	34	33		30					26		24			20	19	18	16				13	12		9	7		4		2
	55		53	51		49	48	47		44																																													
		40		37	36	35	34	33		30																																													
			26		24			20	19	18	16																																												
			13	12		9	7		4		2																																												

ENTER DESCRIPTION EC NO: UAU2010-1803 DRAWN BY: CHKD:TSK IVER APPR:VKOSHY DATE: 2010/06/02 DATE: 2008/02/20 DATE: 2010/06/04	QUALITY SYMBOLS =0 =0	GENERAL TOLERANCES (UNLESS SPECIFIED) <table border="1"> <tr><th></th><th>mm</th><th>INCH</th></tr> <tr><td>4 PLACES</td><td>±---</td><td>±---</td></tr> <tr><td>3 PLACES</td><td>±---</td><td>±---</td></tr> <tr><td>2 PLACES</td><td>±---</td><td>±---</td></tr> <tr><td>1 PLACE</td><td>±---</td><td>±---</td></tr> </table>		mm	INCH	4 PLACES	±---	±---	3 PLACES	±---	±---	2 PLACES	±---	±---	1 PLACE	±---	±---	DIMENSION STYLE MM ONLY	SCALE SCALE	DESIGN UNITS METRIC	THIRD ANGLE PROJECTION
		mm	INCH																		
	4 PLACES	±---	±---																		
	3 PLACES	±---	±---																		
2 PLACES	±---	±---																			
1 PLACE	±---	±---																			
REVISIONS 15	DRAFT WHERE APPLICABLE MUST REMAIN WITHIN DIMENSIONS	APPROVED BY VKOSHY DATE: 2008/02/20	DRAWN BY SRAJENDRANAT DATE: 2008/02/20	CHECKED BY TSK IVER DATE: 2008/02/20	TITLE MX123 49/56 CKT HRNS CONN ASSY	MOLEX INCORPORATED															
		MATERIAL NO. SEE BOM TABLE	DOCUMENT NO. SD-34576-001	SHEET NO. 8 OF 11																	
		THIS DRAWING CONTAINS INFORMATION THAT IS PROPRIETARY TO MOLEX INCORPORATED AND SHOULD NOT BE USED WITHOUT WRITTEN PERMISSION																			

19 18 17 16 15 14 13 12 11 10 9 8 7 6 5 4 3 2 1

20 19 18 17 16 15 14 13 12 11 10 9 8 7 6 5 4 3 2 1

34576

STATUS	GM PART #	MATERIAL #	PART/MATERIAL REVISION	WIRE DRESS OPTION	KEY OPTION	COLOR (TPA)	NUMBERS INDICATE CAVITIES OPEN FOR CIRCUITS																																																							
AVAILABLE	NOT APPLICABLE	34576-5203	F	0	G	BLUE	<table border="1"> <tr><td>56</td><td>55</td><td>54</td><td>53</td><td></td><td></td><td>49</td><td>48</td><td>47</td><td></td><td>44</td></tr> <tr><td></td><td></td><td>40</td><td>39</td><td></td><td>37</td><td>36</td><td>35</td><td>34</td><td>33</td><td></td><td>29</td></tr> <tr><td></td><td></td><td></td><td></td><td></td><td></td><td></td><td></td><td>20</td><td>19</td><td>18</td><td></td><td>15</td></tr> <tr><td></td><td></td><td>13</td><td>12</td><td></td><td></td><td>9</td><td>7</td><td></td><td></td><td></td><td></td><td></td></tr> </table>	56	55	54	53			49	48	47		44			40	39		37	36	35	34	33		29									20	19	18		15			13	12			9	7											
56	55	54	53			49	48	47		44																																																				
		40	39		37	36	35	34	33		29																																																			
								20	19	18		15																																																		
		13	12			9	7																																																							
AVAILABLE	NOT APPLICABLE	34576-5403	F	0	G	BLUE	<table border="1"> <tr><td></td><td>55</td><td></td><td>53</td><td></td><td>51</td><td></td><td>49</td><td>48</td><td>47</td><td></td><td>44</td><td></td></tr> <tr><td></td><td></td><td>40</td><td>39</td><td></td><td>37</td><td>36</td><td>35</td><td>34</td><td>33</td><td></td><td>30</td><td></td></tr> <tr><td></td><td></td><td>26</td><td>25</td><td></td><td></td><td>22</td><td>21</td><td>20</td><td>19</td><td>18</td><td>16</td><td></td></tr> <tr><td></td><td></td><td>13</td><td>12</td><td></td><td></td><td>9</td><td>7</td><td></td><td></td><td>4</td><td>2</td><td>1</td></tr> </table>		55		53		51		49	48	47		44				40	39		37	36	35	34	33		30				26	25			22	21	20	19	18	16				13	12			9	7			4	2	1			
	55		53		51		49	48	47		44																																																			
		40	39		37	36	35	34	33		30																																																			
		26	25			22	21	20	19	18	16																																																			
		13	12			9	7			4	2	1																																																		
AVAILABLE	NOT APPLICABLE	34576-5503	F	0	G	BLUE	<table border="1"> <tr><td>56</td><td>55</td><td></td><td>53</td><td></td><td>51</td><td></td><td>49</td><td>48</td><td>47</td><td></td><td>44</td><td></td></tr> <tr><td></td><td></td><td>40</td><td>39</td><td></td><td>37</td><td>36</td><td>35</td><td>34</td><td>33</td><td></td><td>30</td><td></td></tr> <tr><td></td><td></td><td></td><td>25</td><td></td><td>22</td><td>21</td><td>20</td><td>19</td><td>18</td><td></td><td>16</td><td></td></tr> <tr><td></td><td></td><td>13</td><td>12</td><td></td><td></td><td>9</td><td>7</td><td></td><td></td><td>4</td><td>2</td><td>1</td></tr> </table>	56	55		53		51		49	48	47		44				40	39		37	36	35	34	33		30					25		22	21	20	19	18		16				13	12			9	7			4	2	1			
56	55		53		51		49	48	47		44																																																			
		40	39		37	36	35	34	33		30																																																			
			25		22	21	20	19	18		16																																																			
		13	12			9	7			4	2	1																																																		
AVAILABLE	NOT APPLICABLE	34576-5603	F	0	G	BLUE	<table border="1"> <tr><td>56</td><td>55</td><td></td><td>53</td><td></td><td></td><td>49</td><td>48</td><td>47</td><td>46</td><td></td><td>44</td><td></td></tr> <tr><td></td><td></td><td>40</td><td>39</td><td></td><td>37</td><td>36</td><td>35</td><td>34</td><td>33</td><td>32</td><td>31</td><td>30</td></tr> <tr><td></td><td></td><td></td><td>25</td><td></td><td>22</td><td>21</td><td>20</td><td>19</td><td>18</td><td></td><td>16</td><td></td></tr> <tr><td></td><td></td><td>13</td><td>12</td><td></td><td></td><td>9</td><td>7</td><td></td><td></td><td>4</td><td>2</td><td>1</td></tr> </table>	56	55		53			49	48	47	46		44				40	39		37	36	35	34	33	32	31	30				25		22	21	20	19	18		16				13	12			9	7			4	2	1			
56	55		53			49	48	47	46		44																																																			
		40	39		37	36	35	34	33	32	31	30																																																		
			25		22	21	20	19	18		16																																																			
		13	12			9	7			4	2	1																																																		
AVAILABLE	NOT APPLICABLE	34576-5703	F	0	G	BLUE	<table border="1"> <tr><td></td><td>55</td><td></td><td>53</td><td></td><td></td><td>49</td><td>48</td><td>47</td><td>46</td><td></td><td>44</td><td></td></tr> <tr><td></td><td></td><td>40</td><td>39</td><td></td><td>37</td><td>36</td><td>35</td><td>34</td><td>33</td><td>32</td><td>31</td><td>30</td></tr> <tr><td></td><td></td><td>26</td><td>25</td><td></td><td>22</td><td>21</td><td>20</td><td>19</td><td>18</td><td></td><td>16</td><td></td></tr> <tr><td></td><td></td><td>13</td><td>12</td><td></td><td></td><td>9</td><td>7</td><td></td><td></td><td>4</td><td>2</td><td>1</td></tr> </table>		55		53			49	48	47	46		44				40	39		37	36	35	34	33	32	31	30			26	25		22	21	20	19	18		16				13	12			9	7			4	2	1			
	55		53			49	48	47	46		44																																																			
		40	39		37	36	35	34	33	32	31	30																																																		
		26	25		22	21	20	19	18		16																																																			
		13	12			9	7			4	2	1																																																		
AVAILABLE	NOT APPLICABLE	34576-5803	F	0	G	BLUE	<table border="1"> <tr><td></td><td>55</td><td></td><td>53</td><td></td><td></td><td>49</td><td>48</td><td>47</td><td>46</td><td>45</td><td>44</td><td></td></tr> <tr><td></td><td></td><td>40</td><td>39</td><td></td><td>37</td><td>36</td><td>35</td><td>34</td><td>33</td><td></td><td></td><td></td></tr> <tr><td></td><td></td><td>26</td><td>25</td><td></td><td></td><td></td><td></td><td>20</td><td>19</td><td>18</td><td></td><td></td></tr> <tr><td></td><td></td><td>13</td><td>12</td><td></td><td></td><td>9</td><td>7</td><td></td><td></td><td></td><td></td><td></td></tr> </table>		55		53			49	48	47	46	45	44				40	39		37	36	35	34	33						26	25					20	19	18					13	12			9	7								
	55		53			49	48	47	46	45	44																																																			
		40	39		37	36	35	34	33																																																					
		26	25					20	19	18																																																				
		13	12			9	7																																																							
AVAILABLE	NOT APPLICABLE	34576-5903	F	0	G	BLUE	<table border="1"> <tr><td>56</td><td></td><td></td><td>53</td><td>52</td><td></td><td></td><td></td><td></td><td>47</td><td></td><td>45</td><td>43</td></tr> <tr><td>41</td><td>40</td><td>39</td><td>38</td><td></td><td></td><td></td><td></td><td></td><td>34</td><td>33</td><td>31</td><td>30</td><td>29</td></tr> <tr><td>28</td><td>27</td><td>26</td><td>25</td><td>24</td><td></td><td></td><td></td><td></td><td>20</td><td>19</td><td>18</td><td>16</td><td></td></tr> <tr><td>13</td><td>12</td><td>11</td><td>10</td><td></td><td></td><td></td><td></td><td></td><td></td><td></td><td>3</td><td>2</td><td></td></tr> </table>	56			53	52					47		45	43	41	40	39	38						34	33	31	30	29	28	27	26	25	24					20	19	18	16		13	12	11	10								3	2	
56			53	52					47		45	43																																																		
41	40	39	38						34	33	31	30	29																																																	
28	27	26	25	24					20	19	18	16																																																		
13	12	11	10								3	2																																																		
AVAILABLE	NOT APPLICABLE	34576-6003	F	0	G	BLUE	<table border="1"> <tr><td>56</td><td></td><td></td><td>53</td><td>52</td><td></td><td>50</td><td></td><td></td><td>47</td><td></td><td>45</td><td>43</td></tr> <tr><td></td><td>40</td><td>39</td><td>38</td><td></td><td></td><td></td><td></td><td></td><td>34</td><td>33</td><td>31</td><td>30</td><td>29</td></tr> <tr><td>28</td><td>27</td><td>26</td><td>25</td><td>24</td><td></td><td></td><td></td><td></td><td>20</td><td>19</td><td>18</td><td>16</td><td></td></tr> <tr><td>14</td><td>13</td><td>12</td><td>11</td><td>10</td><td></td><td></td><td></td><td></td><td></td><td>5</td><td>4</td><td>3</td><td>2</td></tr> </table>	56			53	52		50			47		45	43		40	39	38						34	33	31	30	29	28	27	26	25	24					20	19	18	16		14	13	12	11	10						5	4	3	2
56			53	52		50			47		45	43																																																		
	40	39	38						34	33	31	30	29																																																	
28	27	26	25	24					20	19	18	16																																																		
14	13	12	11	10						5	4	3	2																																																	
AVAILABLE	NOT APPLICABLE	34576-6103	F	0	G	BLUE	<table border="1"> <tr><td>56</td><td>55</td><td>54</td><td>53</td><td></td><td>51</td><td></td><td>49</td><td>48</td><td>47</td><td></td><td>44</td><td></td></tr> <tr><td></td><td></td><td>40</td><td>39</td><td></td><td>37</td><td>36</td><td>35</td><td>34</td><td>33</td><td></td><td>30</td><td>29</td></tr> <tr><td></td><td></td><td></td><td></td><td></td><td></td><td></td><td></td><td></td><td>20</td><td>19</td><td>18</td><td>16</td><td>15</td></tr> <tr><td></td><td></td><td>13</td><td>12</td><td></td><td></td><td>9</td><td>7</td><td></td><td></td><td>4</td><td>2</td><td></td><td></td></tr> </table>	56	55	54	53		51		49	48	47		44				40	39		37	36	35	34	33		30	29										20	19	18	16	15			13	12			9	7			4	2			
56	55	54	53		51		49	48	47		44																																																			
		40	39		37	36	35	34	33		30	29																																																		
									20	19	18	16	15																																																	
		13	12			9	7			4	2																																																			

ENTER DESCRIPTION EC NO: UAU2010-1803 DRAWN: H01 CHECKED: TSK IVER APPROVED: VKOSHY DATE: 2010/06/02 DATE: 2008/02/20 DATE: 2010/06/04	QUALITY SYMBOLS ▽=0 ▽=0	GENERAL TOLERANCES (UNLESS SPECIFIED) <table border="1"> <tr><th></th><th>mm</th><th>INCH</th></tr> <tr><td>4 PLACES</td><td>±----</td><td>±----</td></tr> <tr><td>3 PLACES</td><td>±----</td><td>±----</td></tr> <tr><td>2 PLACES</td><td>±----</td><td>±----</td></tr> <tr><td>1 PLACE</td><td>±----</td><td>±----</td></tr> </table>		mm	INCH	4 PLACES	±----	±----	3 PLACES	±----	±----	2 PLACES	±----	±----	1 PLACE	±----	±----	DIMENSION STYLE MM ONLY	SCALE SCALE	DESIGN UNITS METRIC	THIRD ANGLE PROJECTION
		mm	INCH																		
	4 PLACES	±----	±----																		
	3 PLACES	±----	±----																		
2 PLACES	±----	±----																			
1 PLACE	±----	±----																			
DRAWN BY SRAJENDRANAT	DATE 2008/02/20	CHECKED BY TSK IVER	DATE 2008/02/20	TITLE MX123 49/56 CKT HRNS CONN ASSY																	
APPROVED BY VKOSHY	DATE 2008/02/20	MOLEX INCORPORATED																			
MATERIAL NO. SEE BOM TABLE	DOCUMENT NO. SD-34576-001	SHEET NO. 9 OF 11	THIS DRAWING CONTAINS INFORMATION THAT IS PROPRIETARY TO MOLEX INCORPORATED AND SHOULD NOT BE USED WITHOUT WRITTEN PERMISSION																		

19 18 17 16 15 14 13 12 11 10 9 8 7 6 5 4 3 2 1

STATUS	GM PART #	MATERIAL #	PART/MATERIAL REVISION	WIRE DRESS OPTION	KEY OPTION	COLOR (TFA)	NUMBERS INDICATE CAVITIES OPEN FOR CIRCUITS																																																							
AVAILABLE	NOT APPLICABLE	34576-6203	G	0	G	BLUE	<table border="1"> <tr><td>55</td><td>54</td><td>53</td><td></td><td></td><td>49</td><td>48</td><td>47</td><td>46</td><td>45</td><td>44</td></tr> <tr><td>40</td><td></td><td></td><td>37</td><td>36</td><td>35</td><td>34</td><td>33</td><td></td><td></td><td></td></tr> <tr><td></td><td>26</td><td></td><td></td><td></td><td></td><td>20</td><td>19</td><td>18</td><td></td><td></td></tr> <tr><td>13</td><td>12</td><td></td><td>9</td><td>7</td><td></td><td></td><td></td><td></td><td></td><td></td></tr> </table>	55	54	53			49	48	47	46	45	44	40			37	36	35	34	33					26					20	19	18			13	12		9	7																	
55	54	53			49	48	47	46	45	44																																																				
40			37	36	35	34	33																																																							
	26					20	19	18																																																						
13	12		9	7																																																										
AVAILABLE	NOT APPLICABLE	34576-6303	G	0	G	BLUE	<table border="1"> <tr><td>55</td><td>54</td><td>53</td><td>51</td><td>49</td><td>48</td><td>47</td><td></td><td></td><td>44</td><td></td></tr> <tr><td>40</td><td>39</td><td>37</td><td>36</td><td>35</td><td>34</td><td>33</td><td></td><td></td><td></td><td>29</td></tr> <tr><td>26</td><td></td><td></td><td></td><td>20</td><td>19</td><td>18</td><td></td><td></td><td>16</td><td>15</td></tr> <tr><td>13</td><td>12</td><td></td><td>9</td><td>7</td><td></td><td>4</td><td></td><td>2</td><td></td><td></td></tr> </table>	55	54	53	51	49	48	47			44		40	39	37	36	35	34	33				29	26				20	19	18			16	15	13	12		9	7		4		2													
55	54	53	51	49	48	47			44																																																					
40	39	37	36	35	34	33				29																																																				
26				20	19	18			16	15																																																				
13	12		9	7		4		2																																																						
AVAILABLE	NOT APPLICABLE	34576-6403	G	0	G	BLUE	<table border="1"> <tr><td>55</td><td>54</td><td></td><td></td><td>49</td><td>48</td><td>47</td><td></td><td></td><td>44</td><td></td></tr> <tr><td>41</td><td>40</td><td></td><td>37</td><td>36</td><td>35</td><td>34</td><td>33</td><td></td><td></td><td></td></tr> <tr><td></td><td></td><td></td><td></td><td></td><td></td><td>20</td><td>19</td><td>18</td><td></td><td></td></tr> <tr><td>13</td><td>12</td><td></td><td>9</td><td>8</td><td>7</td><td></td><td></td><td></td><td>3</td><td></td></tr> </table>	55	54			49	48	47			44		41	40		37	36	35	34	33										20	19	18			13	12		9	8	7				3												
55	54			49	48	47			44																																																					
41	40		37	36	35	34	33																																																							
						20	19	18																																																						
13	12		9	8	7				3																																																					
AVAILABLE	NOT APPLICABLE	34576-6503	G	0	G	BLUE	<table border="1"> <tr><td></td><td>54</td><td></td><td></td><td></td><td></td><td>47</td><td>46</td><td>45</td><td>43</td><td></td></tr> <tr><td>41</td><td>40</td><td>39</td><td>38</td><td>37</td><td></td><td>33</td><td>32</td><td>31</td><td>30</td><td>29</td></tr> <tr><td>28</td><td>27</td><td>26</td><td>25</td><td>24</td><td>23</td><td></td><td>20</td><td>19</td><td>18</td><td>16</td></tr> <tr><td>13</td><td>12</td><td>11</td><td>10</td><td>9</td><td></td><td></td><td></td><td></td><td>3</td><td>2</td></tr> </table>		54					47	46	45	43		41	40	39	38	37		33	32	31	30	29	28	27	26	25	24	23		20	19	18	16	13	12	11	10	9					3	2											
	54					47	46	45	43																																																					
41	40	39	38	37		33	32	31	30	29																																																				
28	27	26	25	24	23		20	19	18	16																																																				
13	12	11	10	9					3	2																																																				
AVAILABLE	NOT APPLICABLE	34576-6603	G	0	G	BLUE	<table border="1"> <tr><td></td><td>54</td><td></td><td></td><td></td><td></td><td>47</td><td>46</td><td>45</td><td>43</td><td></td></tr> <tr><td>41</td><td>40</td><td>39</td><td>38</td><td>37</td><td></td><td>34</td><td>33</td><td>32</td><td>31</td><td>30</td></tr> <tr><td>28</td><td>27</td><td>26</td><td>25</td><td>24</td><td>23</td><td></td><td>20</td><td>19</td><td>18</td><td>16</td></tr> <tr><td>13</td><td>12</td><td>11</td><td>10</td><td>9</td><td></td><td></td><td></td><td></td><td>3</td><td>2</td></tr> </table>		54					47	46	45	43		41	40	39	38	37		34	33	32	31	30	28	27	26	25	24	23		20	19	18	16	13	12	11	10	9					3	2											
	54					47	46	45	43																																																					
41	40	39	38	37		34	33	32	31	30																																																				
28	27	26	25	24	23		20	19	18	16																																																				
13	12	11	10	9					3	2																																																				
AVAILABLE	NOT APPLICABLE	34576-6703	G	0	G	BLUE	<table border="1"> <tr><td>55</td><td></td><td></td><td>52</td><td>51</td><td></td><td>48</td><td></td><td>46</td><td>45</td><td>43</td></tr> <tr><td>41</td><td>40</td><td>39</td><td>38</td><td></td><td></td><td></td><td></td><td>33</td><td>32</td><td>31</td></tr> <tr><td>28</td><td>26</td><td>25</td><td>24</td><td></td><td></td><td>20</td><td>19</td><td>18</td><td>16</td><td>15</td></tr> <tr><td>13</td><td>12</td><td>11</td><td>10</td><td></td><td></td><td></td><td></td><td></td><td>3</td><td>2</td></tr> <tr><td></td><td></td><td></td><td></td><td></td><td></td><td></td><td></td><td></td><td></td><td>1</td></tr> </table>	55			52	51		48		46	45	43	41	40	39	38					33	32	31	28	26	25	24			20	19	18	16	15	13	12	11	10						3	2											1
55			52	51		48		46	45	43																																																				
41	40	39	38					33	32	31																																																				
28	26	25	24			20	19	18	16	15																																																				
13	12	11	10						3	2																																																				
										1																																																				
AVAILABLE	NOT APPLICABLE	34576-6803	G	0	G	BLUE	<table border="1"> <tr><td></td><td></td><td></td><td>52</td><td></td><td></td><td>48</td><td></td><td>46</td><td>45</td><td>43</td></tr> <tr><td>41</td><td>40</td><td>39</td><td>38</td><td></td><td></td><td></td><td></td><td>33</td><td>32</td><td>31</td></tr> <tr><td>28</td><td>26</td><td>25</td><td>24</td><td></td><td></td><td>20</td><td>19</td><td>18</td><td>16</td><td>15</td></tr> <tr><td>13</td><td>12</td><td>11</td><td>10</td><td></td><td></td><td></td><td></td><td></td><td>3</td><td>2</td></tr> <tr><td></td><td></td><td></td><td></td><td></td><td></td><td></td><td></td><td></td><td></td><td>1</td></tr> </table>				52			48		46	45	43	41	40	39	38					33	32	31	28	26	25	24			20	19	18	16	15	13	12	11	10						3	2											1
			52			48		46	45	43																																																				
41	40	39	38					33	32	31																																																				
28	26	25	24			20	19	18	16	15																																																				
13	12	11	10						3	2																																																				
										1																																																				
AVAILABLE	NOT APPLICABLE	34576-6813	G	0	G	BLUE	<table border="1"> <tr><td>56</td><td>55</td><td>54</td><td>53</td><td>51</td><td>50</td><td>49</td><td>47</td><td></td><td></td><td>44</td></tr> <tr><td>42</td><td></td><td>39</td><td>37</td><td>36</td><td>35</td><td>34</td><td></td><td></td><td></td><td></td></tr> <tr><td>27</td><td></td><td>25</td><td>23</td><td>22</td><td>21</td><td></td><td></td><td></td><td>17</td><td></td></tr> <tr><td>14</td><td></td><td>11</td><td>9</td><td>8</td><td>7</td><td>6</td><td>5</td><td>4</td><td></td><td></td></tr> </table>	56	55	54	53	51	50	49	47			44	42		39	37	36	35	34					27		25	23	22	21				17		14		11	9	8	7	6	5	4													
56	55	54	53	51	50	49	47			44																																																				
42		39	37	36	35	34																																																								
27		25	23	22	21				17																																																					
14		11	9	8	7	6	5	4																																																						
AVAILABLE	NOT APPLICABLE	34576-6823	G	0	G	BLUE	<table border="1"> <tr><td>56</td><td>54</td><td>53</td><td></td><td>50</td><td>49</td><td>47</td><td></td><td></td><td>44</td><td></td></tr> <tr><td>42</td><td></td><td>39</td><td>37</td><td>36</td><td>35</td><td>34</td><td></td><td></td><td></td><td></td></tr> <tr><td>27</td><td></td><td>25</td><td>23</td><td>22</td><td>21</td><td></td><td></td><td></td><td>17</td><td></td></tr> <tr><td>14</td><td></td><td>11</td><td>9</td><td>8</td><td>7</td><td>6</td><td>5</td><td>4</td><td></td><td></td></tr> </table>	56	54	53		50	49	47			44		42		39	37	36	35	34					27		25	23	22	21				17		14		11	9	8	7	6	5	4													
56	54	53		50	49	47			44																																																					
42		39	37	36	35	34																																																								
27		25	23	22	21				17																																																					
14		11	9	8	7	6	5	4																																																						

ENTER DESCRIPTION EC NO. UAU2010-1803 DRAWN BY: CHYD:SKIVER DATE: 2008/02/20 APPR: VKOSHY DATE: 2010/06/04	QUALITY SYMBOLS =0 =0	GENERAL TOLERANCES (UNLESS SPECIFIED) mm INCH 4 PLACES ± --- ± --- 3 PLACES ± --- ± --- 2 PLACES ± --- ± --- 1 PLACE ± --- ± --- ANGULAR ± ---°	DIMENSION STYLE MM ONLY	SCALE 1:1	DESIGN UNITS METRIC	THIRD ANGLE PROJECTION	
	DRAWN BY: SRAJENDRANAT DATE: 2008/02/20	CHECKED BY: TSKIVER DATE: 2008/02/20	APPROVED BY: VKOSHY DATE: 2008/02/20	MATERIAL NO.	DOCUMENT NO.	TITLE MX123 49/56 CKT HRNS CONN ASSY	SHEET NO. 10 OF 11
	DRAFT WHERE APPLICABLE MUST REMAIN WITHIN DIMENSIONS			SEE BOM TABLE	MOLEX INCORPORATED		SD-34576-001
	THIS DRAWING CONTAINS INFORMATION THAT IS PROPRIETARY TO MOLEX INCORPORATED AND SHOULD NOT BE USED WITHOUT WRITTEN PERMISSION						

STATUS	GM PART #	MATERIAL #	PART/MATERIAL REVISION	WIRE DRESS OPTION	KEY OPTION	COLOR (TFA)	NUMBERS INDICATE CAVITIES OPEN FOR CIRCUITS																																																						
AVAILABLE	NOT APPLICABLE	34576-6833	G	0	G	BLUE	<table border="1"> <tr><td>56</td><td>54</td><td>53</td><td></td><td></td><td>50</td><td>49</td><td>47</td><td></td><td></td><td></td><td></td></tr> <tr><td></td><td></td><td></td><td></td><td></td><td></td><td>21</td><td></td><td></td><td>17</td><td></td><td></td></tr> <tr><td>14</td><td></td><td>11</td><td>9</td><td>8</td><td>7</td><td>6</td><td>5</td><td>4</td><td></td><td></td><td></td></tr> </table>	56	54	53			50	49	47											21			17			14		11	9	8	7	6	5	4																					
56	54	53			50	49	47																																																						
						21			17																																																				
14		11	9	8	7	6	5	4																																																					
AVAILABLE	NOT APPLICABLE	34576-6843	G	0	G	BLUE	<table border="1"> <tr><td>56</td><td>54</td><td>53</td><td>52</td><td></td><td></td><td></td><td>47</td><td>46</td><td>45</td><td>43</td><td></td></tr> <tr><td></td><td>41</td><td>40</td><td>39</td><td>38</td><td>37</td><td></td><td></td><td>33</td><td>32</td><td>31</td><td>30</td><td>29</td></tr> <tr><td>28</td><td>27</td><td>26</td><td>25</td><td>24</td><td>23</td><td></td><td></td><td>20</td><td>19</td><td>18</td><td></td><td>16</td></tr> <tr><td></td><td>13</td><td>12</td><td>11</td><td>10</td><td>9</td><td></td><td></td><td></td><td></td><td>3</td><td>2</td><td></td></tr> </table>	56	54	53	52				47	46	45	43			41	40	39	38	37			33	32	31	30	29	28	27	26	25	24	23			20	19	18		16		13	12	11	10	9					3	2				
56	54	53	52				47	46	45	43																																																			
	41	40	39	38	37			33	32	31	30	29																																																	
28	27	26	25	24	23			20	19	18		16																																																	
	13	12	11	10	9					3	2																																																		
AVAILABLE	NOT APPLICABLE	34576-6853	G	0	G	BLUE	<table border="1"> <tr><td>56</td><td>54</td><td>53</td><td>52</td><td></td><td></td><td></td><td>47</td><td>46</td><td>45</td><td>43</td><td></td></tr> <tr><td></td><td>41</td><td>40</td><td>39</td><td>38</td><td>37</td><td></td><td></td><td>34</td><td>33</td><td>32</td><td>31</td><td>30</td><td>29</td></tr> <tr><td>28</td><td>27</td><td>26</td><td>25</td><td>24</td><td>23</td><td></td><td></td><td>20</td><td>19</td><td>18</td><td></td><td>16</td><td></td></tr> <tr><td></td><td>13</td><td>12</td><td>11</td><td>10</td><td>9</td><td></td><td></td><td></td><td></td><td></td><td>3</td><td>2</td><td></td></tr> </table>	56	54	53	52				47	46	45	43			41	40	39	38	37			34	33	32	31	30	29	28	27	26	25	24	23			20	19	18		16			13	12	11	10	9						3	2	
56	54	53	52				47	46	45	43																																																			
	41	40	39	38	37			34	33	32	31	30	29																																																
28	27	26	25	24	23			20	19	18		16																																																	
	13	12	11	10	9						3	2																																																	
AVAILABLE	NOT APPLICABLE	34576-6863	G	0	G	BLUE	<table border="1"> <tr><td></td><td>55</td><td></td><td>52</td><td>51</td><td></td><td></td><td>48</td><td>46</td><td>45</td><td>43</td><td></td></tr> <tr><td></td><td>41</td><td>40</td><td>38</td><td></td><td></td><td></td><td></td><td>33</td><td>32</td><td>31</td><td>30</td><td>29</td></tr> <tr><td>28</td><td></td><td>26</td><td>24</td><td></td><td></td><td></td><td>20</td><td>19</td><td>18</td><td></td><td>16</td><td>15</td></tr> <tr><td></td><td>13</td><td>12</td><td>10</td><td></td><td></td><td></td><td></td><td></td><td></td><td>3</td><td>2</td><td>1</td></tr> </table>		55		52	51			48	46	45	43			41	40	38					33	32	31	30	29	28		26	24				20	19	18		16	15		13	12	10							3	2	1			
	55		52	51			48	46	45	43																																																			
	41	40	38					33	32	31	30	29																																																	
28		26	24				20	19	18		16	15																																																	
	13	12	10							3	2	1																																																	
AVAILABLE	NOT APPLICABLE	34576-6873	G	0	G	BLUE	<table border="1"> <tr><td></td><td></td><td></td><td>52</td><td></td><td></td><td></td><td>48</td><td>46</td><td>45</td><td>43</td><td></td></tr> <tr><td></td><td>41</td><td>40</td><td>38</td><td></td><td></td><td></td><td></td><td>33</td><td>32</td><td>31</td><td>30</td><td>29</td></tr> <tr><td>28</td><td></td><td>26</td><td>24</td><td></td><td></td><td></td><td>20</td><td>19</td><td>18</td><td></td><td>16</td><td>15</td></tr> <tr><td></td><td>13</td><td>12</td><td>10</td><td></td><td></td><td></td><td></td><td></td><td></td><td>3</td><td>2</td><td>1</td></tr> </table>				52				48	46	45	43			41	40	38					33	32	31	30	29	28		26	24				20	19	18		16	15		13	12	10							3	2	1			
			52				48	46	45	43																																																			
	41	40	38					33	32	31	30	29																																																	
28		26	24				20	19	18		16	15																																																	
	13	12	10							3	2	1																																																	

ENTER DESCRIPTION EC NO: JAU2010-1803 DRAWN BY: 2010/06/02 CHKD: SKIVER 2008/02/20 APPR: VKOSHY 2010/06/04 REV:	QUALITY SYMBOLS	GENERAL TOLERANCES (UNLESS SPECIFIED)	DIMENSION STYLE	SCALE	DESIGN UNITS	THIRD ANGLE PROJECTION
	▽=0	mm INCH	MM ONLY	1:1	METRIC	
	▽=0	4 PLACES ± --- ± ---	DRAWN BY: SRAJENDRANAT	DATE: 2008/02/20	TITLE: MX123 49/56 CKT HRNS CONN ASSY	
	▽=0	3 PLACES ± --- ± ---	CHECKED BY: TSKIVER	DATE: 2008/02/20	MATERIAL NO: SD-34576-001	SHEET NO: 11 OF 11
	2 PLACES ± --- ± ---	1 PLACE ± --- ± ---	APPROVED BY: VKOSHY	DATE: 2008/02/20	MOLEX INCORPORATED DOCUMENT NO:	
	ANGULAR ± --- ± ---	DRAFT WHERE APPLICABLE MUST REMAIN WITHIN DIMENSIONS	SEE BOM TABLE	THIS DRAWING CONTAINS INFORMATION THAT IS PROPRIETARY TO MOLEX INCORPORATED AND SHOULD NOT BE USED WITHOUT WRITTEN PERMISSION		