



# SY58607U

## 3.2Gbps Precision, 1:2 LVPECL Fanout Buffer with Internal Termination and Fail Safe Input

### General Description

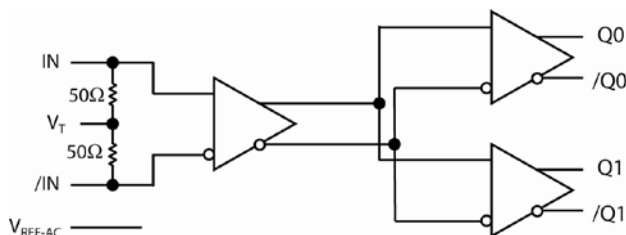
The SY58607U is a 2.5/3.3V, high-speed, fully differential 1:2 LVPECL fanout buffer optimized to provide two identical output copies with less than 20ps of skew and less than 10ps<sub>pp</sub> total jitter. The SY58607U can process clock signals as fast as 2.5GHz or data patterns up to 3.2Gbps.

The differential input includes Micrel's unique, 3-pin input termination architecture that interfaces to LVPECL, LVDS or CML differential signals, (AC- or DC-coupled) as small as 100mV (200mV<sub>pp</sub>) without any level-shifting or termination resistor networks in the signal path. For AC-coupled input interface applications, an integrated voltage reference (V<sub>REF-AC</sub>) is provided to bias the V<sub>T</sub> pin. The outputs are 800mV LVPECL, with extremely fast rise/fall times guaranteed to be less than 110ps.

The SY58607U operates from a 2.5V ±5% supply or 3.3V ±10% supply and is guaranteed over the full industrial temperature range (-40°C to +85°C). For applications that require CML or LVDS outputs, consider the SY58606U and SY58608U, 1:2 fanout buffers with 400mV and 325mV output swings respectively. The SY58607U is part of Micrel's high-speed, Precision Edge® product line.

Datasheets and support documentation can be found on Micrel's web site at: [www.micrel.com](http://www.micrel.com).

### Functional Block Diagram



Precision Edge®

### Features

- Precision 1:2, 800mV LVPECL fanout buffer
- Guaranteed AC performance over temperature and voltage:
  - DC-to > 3.2Gbps throughput
  - <350ps propagation delay (IN-to-Q)
  - <20ps within-device skew
  - <110ps rise/fall times
- Fail Safe Input
  - Prevents outputs from oscillating when input is invalid
- Ultra-low jitter design
  - <1ps<sub>RMS</sub> cycle-to-cycle jitter
  - <10ps<sub>pp</sub> total jitter
  - <1ps<sub>RMS</sub> random jitter
  - <10ps<sub>pp</sub> deterministic jitter
- High-speed LVPECL outputs
- 2.5V ±5% or 3.3V ±10% power supply operation
- Industrial temperature range: -40°C to +85°C
- Available in 16-pin (3mm x 3mm) QFN package

### Applications

- All SONET clock and data distribution
- Fibre Channel clock and data distribution
- Gigabit Ethernet clock and data distribution
- Backplane distribution

### Markets

- Storage
- ATE
- Test and measurement
- Enterprise networking equipment
- High-end servers
- Access
- Metro area network equipment

Precision Edge is a registered trademark of Micrel, Inc.

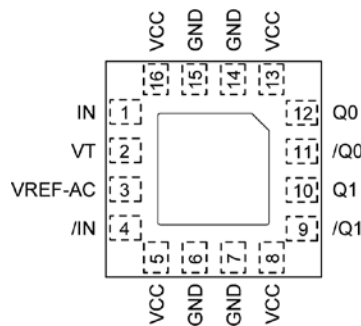
## Ordering Information<sup>(1)</sup>

Part Number	Package Type	Operating Range	Package Marking	Lead Finish
SY58607UMG	QFN-16	Industrial	607U with Pb-Free bar-line indicator	NiPdAu Pb-Free
SY58607UMGTR <sup>(2)</sup>	QFN-16	Industrial	607U with Pb-Free bar-line indicator	NiPdAu Pb-Free

**Notes:**

1. Contact factory for die availability. Dice are guaranteed at TA = 25°C, DC Electricals only.
2. Tape and Reel.

## Pin Configuration



16-Pin QFN

## Pin Description

Pin Number	Pin Name	Pin Function
1, 4	IN, /IN	Differential Input: This input pair is the differential signal input to the device. Input accepts DC-coupled differential signals as small as 100mV (200mVpp). Each pin of this pair internally terminates with 50Ω to the VT pin. If the input swing falls below a certain threshold (typical 30mV), the Fail Safe Input (FSI) feature will guarantee a stable output by latching the output to its last valid state. See “Input Interface Applications” subsection.
2	VT	Input Termination Center-Tap: Each input terminates to this pin. The VT pin provides a center-tap for each input (IN, /IN) to a termination network for maximum interface flexibility. See “Input Interface Applications” subsection.
4	VREF-AC	Reference Voltage: This output biases to V <sub>CC</sub> -1.2V. It is used for AC-coupling inputs IN and /IN. Connect VREF-AC directly to the corresponding VT pin. Bypass with 0.01μF low ESR capacitor to V <sub>CC</sub> . Maximum sink/source current is ±1.5mA. See “Input Interface Applications” subsection.
5, 8, 13, 16	VCC	Positive Power Supply: Bypass with 0.1uF//0.01uF low ESR capacitors as close to the V <sub>CC</sub> pins as possible.
6, 7, 14, 15	GND, Exposed pad	Ground: Exposed pad must be connected to a ground plane that is the same potential as the ground pins.
9, 10 11, 12	/Q1, Q1 /Q0, Q0	LVPECL Differential Output Pairs: Differential buffered copies of the input signal. The output swing is typically 800mV. Unused output pair may be left floating with no impact on jitter. See “LVPECL Output Termination” subsection.

### Absolute Maximum Ratings<sup>(1)</sup>

Supply Voltage ( $V_{CC}$ ) ..... -0.5V to +4.0V  
 Input Voltage ( $V_{IN}$ ) ..... -0.5V to  $V_{CC}$   
 LVPECL Output Current( $I_{OUT}$ )  
     Continuous.....50mA  
     Surge ..... 100mA  
 Current ( $V_T$ )  
     Source or sink on  $V_T$  pin .....±100mA  
 Input Current  
     Source or sink Current on (IN, /IN) .....±50mA  
 Current ( $V_{REF}$ )  
     Source or sink current on  $V_{REF-AC}$ <sup>(4)</sup> .....±1.5mA  
 Maximum operating Junction Temperature ..... 125°C  
 Lead Temperature (soldering, 20sec.) ..... 260°C  
 Storage Temperature ( $T_s$ ) ..... -65°C to +150°C

### Operating Ratings<sup>(2)</sup>

Supply Voltage ( $V_{IN}$ ) ..... +2.375V to +3.60V  
 Ambient Temperature ( $T_A$ ) ..... -40°C to +85°C  
 Package Thermal Resistance<sup>(3)</sup>  
 QFN  
     Still-air ( $\theta_{JA}$ ) ..... 60°C/W  
     Junction-to-board ( $\psi_{JB}$ ) ..... 33°C/W

### DC Electrical Characteristics<sup>(5)</sup>

$T_A = -40^\circ\text{C}$  to  $+85^\circ\text{C}$ , unless otherwise stated.

Symbol	Parameter	Condition	Min	Typ	Max	Units
$V_{CC}$	Power Supply Voltage Range		2.375 3.0	2.5 3.3	2.625 3.6	V
$I_{CC}$	Power Supply Current	No load, max. $V_{CC}$		40	60	mA
$R_{DIFF\_IN}$	Differential Input Resistance (IN-to-/IN)		90	100	110	$\Omega$
$V_{IH}$	Input HIGH Voltage (IN, /IN)	IN, /IN, Note 7	$V_{CC}-1.6$		$V_{CC}$	V
$V_{IL}$	Input LOW Voltage (IN, /IN)	IN, /IN	0		$V_{IH}-0.1$	V
$V_{IN}$	Input Voltage Swing (IN, /IN)	see Figure 3a, Note 6	0.1		1.7	V
$V_{DIFF\_IN}$	Differential Input Voltage Swing ( IN - /IN )	see Figure 3b	0.2			V
$V_{IN\_FSI}$	Input Voltage Threshold that Triggers FSI			30	100	mV
$V_{REF-AC}$	Output Reference Voltage		$V_{CC}-1.3$	$V_{CC}-1.2$	$V_{CC}-1.1$	V
IN to $V_T$					1.28	V

**Notes:**

1. Permanent device damage may occur if absolute maximum ratings are exceeded. This is a stress rating only and functional operation is not implied at conditions other than those detailed in the operational sections of this data sheet. Exposure to absolute maximum ratings conditions for extended periods may affect device reliability.
2. The data sheet limits are not guaranteed if the device is operated beyond the operating ratings.
3. Package thermal resistance assumes exposed pad is soldered (or equivalent) to the device's most negative potential on the PCB.  $\psi_{JB}$  and  $\theta_{JA}$  values are determined for a 4-layer board in still-air number, unless otherwise stated.
4. Due to the limited drive capability, use for input of the same package only.
5. The circuit is designed to meet the DC specifications shown in the above table after thermal equilibrium has been established.
6.  $V_{IN}$  (max) is specified when  $V_T$  is floating.
7.  $V_{IH}$  (min) not lower than 1.2V.

## LVPECL Outputs DC Electrical Characteristics<sup>(7)</sup>

$V_{CC} = +2.5V \pm 5\%$  or  $+3.3V \pm 10\%$ ,  $R_L = 50\Omega$  to  $V_{CC}-2V$ ;  $T_A = -40^\circ C$  to  $+85^\circ C$ , unless otherwise stated.

Symbol	Parameter	Condition	Min	Typ	Max	Units
$V_{OH}$	Output HIGH Voltage	Q0, /Q0, Q1, /Q1	$V_{CC}-1.145$		$V_{CC}-0.895$	V
$V_{OL}$	Output LOW Voltage	Q0, /Q0, Q1, /Q1	$V_{CC}-1.945$		$V_{CC}-1.695$	V
$V_{OUT}$	Output Voltage Swing	See Figure 3a	550	800	950	mV
$V_{DIFF\_OUT}$	Differential Output Voltage Swing	See Figure 3b	1100	1600		mV

### Notes:

7. The circuit is designed to meet the DC specifications shown in the above table after thermal equilibrium has been established.

## AC Electrical Characteristics

$V_{CC} = +2.5V \pm 5\%$  or  $+3.3V \pm 10\%$ ,  $R_L = 50\Omega$  to  $V_{CC}-2V$ , Input  $t_r/t_f: \leq 300ps$ ;  $T_A = -40^\circ C$  to  $+85^\circ C$ , unless otherwise stated.

Symbol	Parameter	Condition	Min	Typ	Max	Units
$f_{MAX}$	Maximum Frequency	NRZ Data	3.2	4.25		Gbps
		$V_{OUT} > 400mV$ Clock	2.5	3		GHz
$t_{PD}$	Propagation Delay IN-to-Q	$V_{IN}: 100mV-200mV$	180	300	450	ps
		$V_{IN}: 200mV-800mV$	150	230	350	ps
$t_{Skew}$	Within Device Skew	Note 8		4	20	ps
	Part-to-Part Skew	Note 9			135	ps
$t_{Jitter}$	Data Random Jitter	Note 10			1	$\mu SRMS$
	Deterministic Jitter	Note 12			10	$\mu SPP$
	Clock Cycle-to-Cycle Jitter	Note 13			1	$\mu SRMS$
	Total Jitter	Note 13			10	$\mu SPP$
$t_r, t_f$	Output Rise/Fall Time (20% to 80%)	At full output swing.	40	75	110	ps
	Duty Cycle	Differential I/O	47		53	%

### Notes:

- Within device skew is measured between two different outputs under identical input transitions.
- Part-to-part skew is defined for two parts with identical power supply voltages at the same temperature and no skew at the edges at the respective inputs.
- Random jitter is measured with a K28.7 pattern, measured at  $\leq f_{MAX}$ .
- Deterministic jitter is measured at 2.5Gbps with both K28.5 and  $2^{23}-1$  PRBS pattern.
- Cycle-to-cycle jitter definition: the variation period between adjacent cycles over a random sample of adjacent cycle pairs.  $t_{JITTER\_CC} = T_n - T_{n+1}$ , where T is the time between rising edges of the output signal.
- Total jitter definition: with an ideal clock input frequency of  $\leq f_{MAX}$  (device), no more than one output edge in  $10^{12}$  output edges will deviate by more than the specified peak-to-peak jitter value.

## Functional Description

### Fail-Safe Input (FSI)

The input includes a special failsafe circuit to sense the amplitude of the input signal and to latch the outputs when there is no input signal present, or when the amplitude of the input signal drops sufficiently below  $100\text{mV}_{\text{PK}}$  ( $200\text{mV}_{\text{PP}}$ ), typically  $30\text{mV}_{\text{PK}}$ . Maximum frequency of SY58607U is limited by the FSI function.

### Input Clock Failure Case

If the input clock fails to a floating, static, or extremely low signal swing, the FSI function will eliminate a metastable condition and guarantee a stable output. No ringing and no undetermined state will occur at the output under these conditions.

Note that the FSI function will not prevent duty cycle distortion in case of a slowly deteriorating (but still toggling) input signal. Due to the FSI function, the propagation delay will depend on rise and fall time of the input signal and on its amplitude. Refer to "Typical Characteristics" for detailed information.

## Timing Diagrams

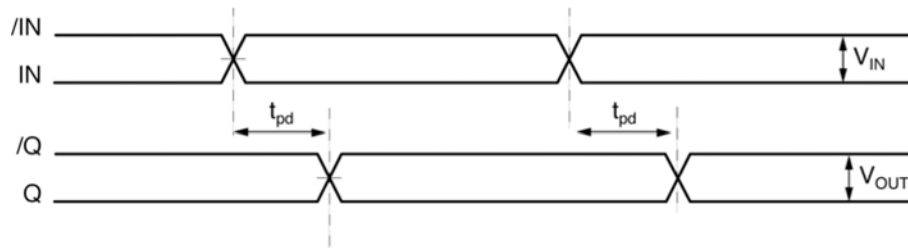


Figure 1a. Propagation Delay

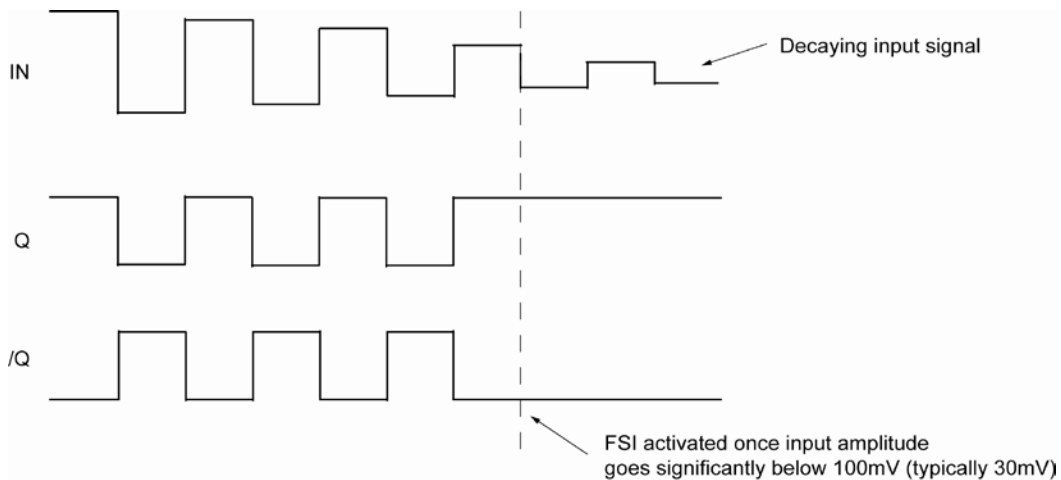
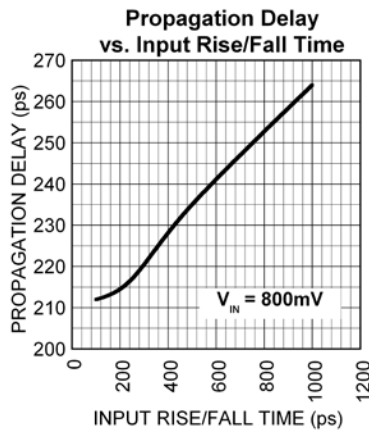
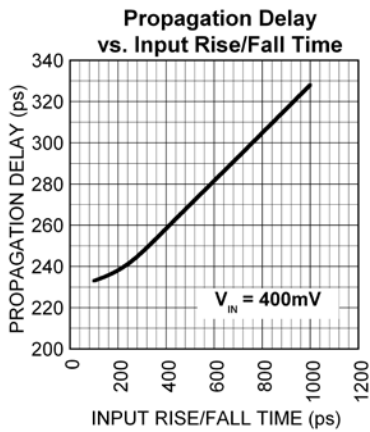
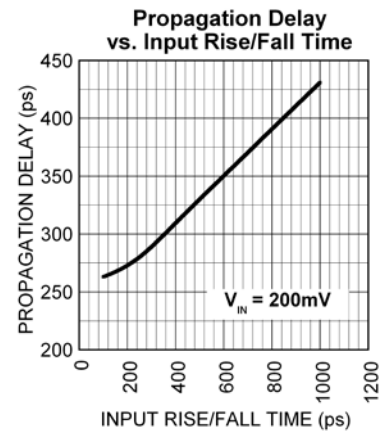
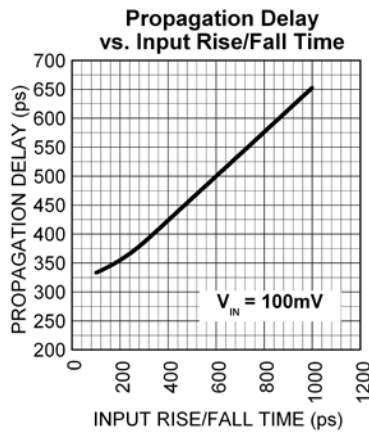
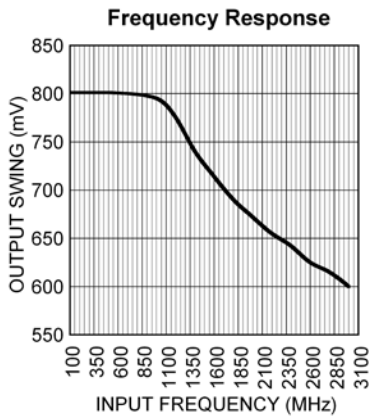


Figure 1b. Fail Safe Feature

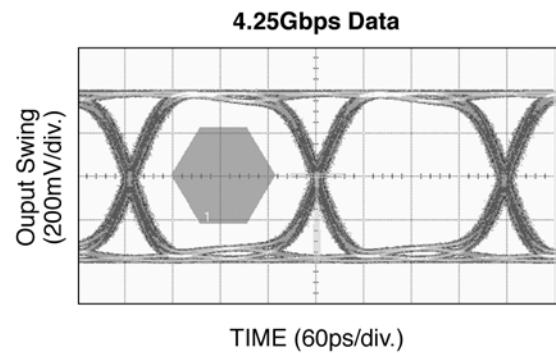
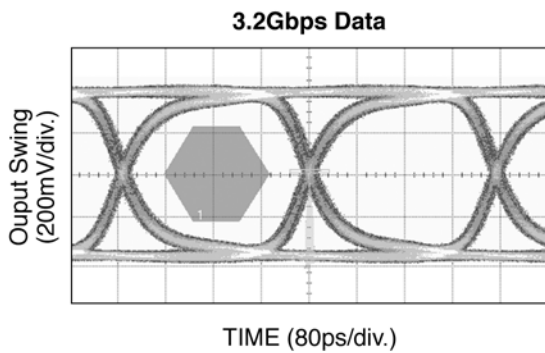
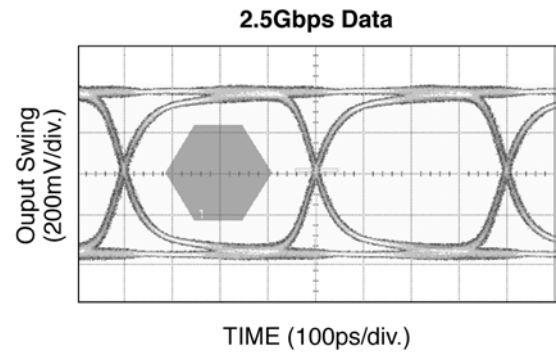
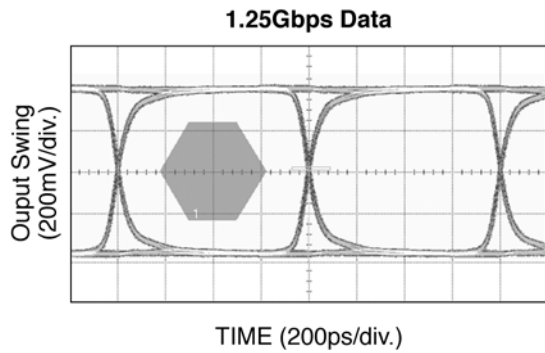
### Typical Characteristics

$V_{CC} = 3.3V$ ,  $GND = 0V$ ,  $V_{IN} = 100mV$ ,  $R_L = 50\Omega$  to  $V_{CC}-2V$ ,  $T_A = 25^\circ C$ , unless otherwise stated.



### Functional Characteristics

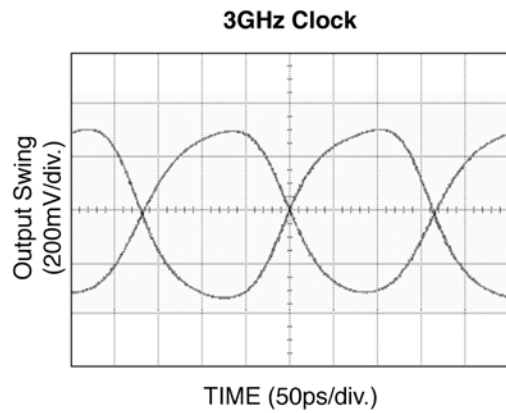
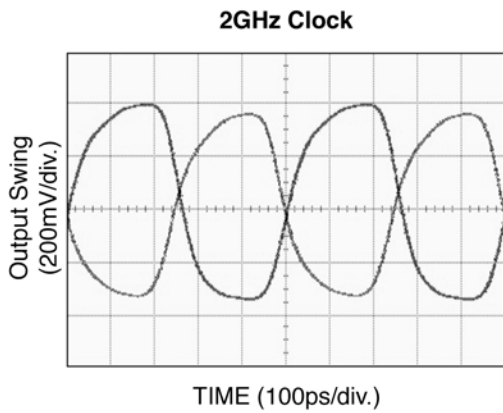
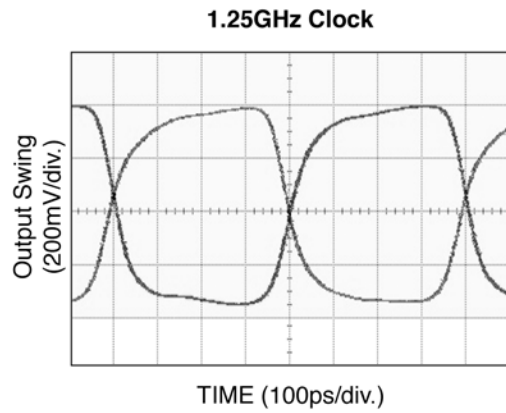
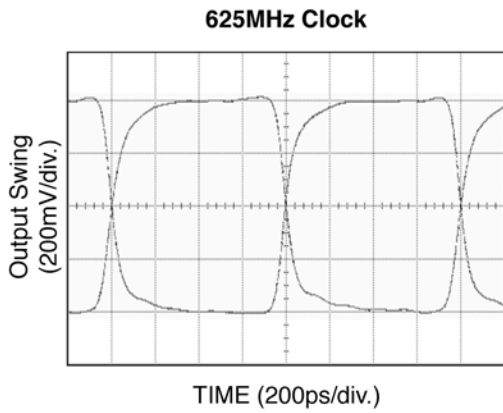
$V_{CC} = 3.3V$ ,  $GND = 0V$ ,  $V_{IN} = 400mV$ , Data Pattern:  $2^{23}-1$ ,  $R_L = 50\Omega$  to  $V_{CC}-2V$ ,  $T_A = 25^\circ C$ , unless otherwise stated.





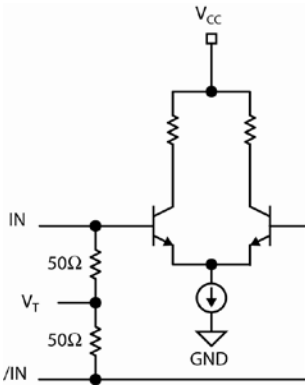
### Functional Characteristics (continued)

$V_{CC} = 3.3V$ ,  $GND = 0V$ ,  $V_{IN} = 400mV$ ,  $R_L = 50\Omega$  to  $V_{CC}-2V$ ,  $T_A = 25^\circ C$ , unless otherwise stated.

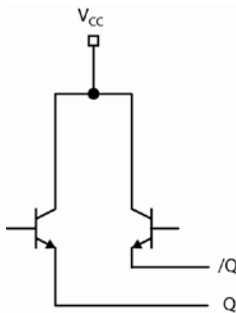


**Input and Output Stage**

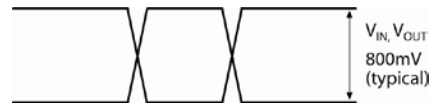
**Single-Ended and Differential Swings**



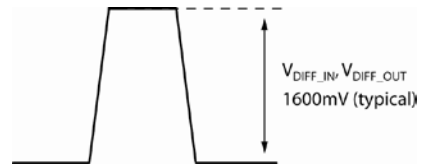
**Figure 2a. Simplified Differential Input Buffer**



**Figure 2b. Simplified LVPECL Output Buffer**

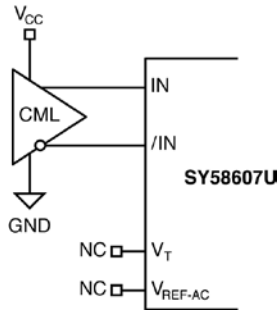


**Figure 3a. Single-Ended Voltage Swing**



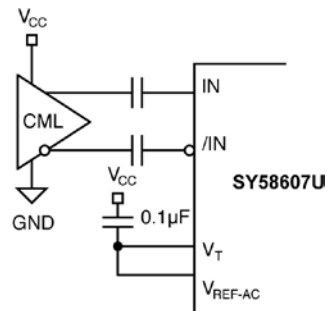
**Figure 3b. Differential Voltage Swing**

## Input Interface Applications

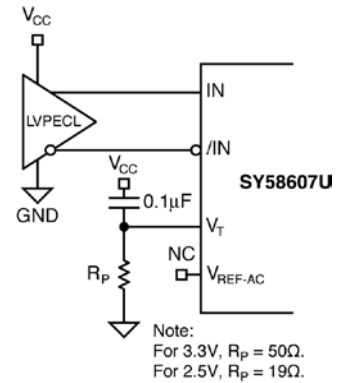


**Figure 4a. CML Interface (DC-Coupled)**

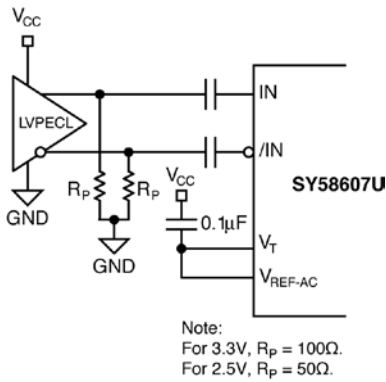
*Option: May connect  $V_T$  to  $V_{CC}$*



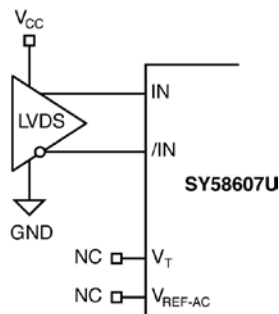
**Figure 4b. CML Interface (AC-Coupled)**



**Figure 4c. LVPECL Interface (DC-Coupled)**



**Figure 4d. LVPECL Interface (AC-Coupled)**



**Figure 4e. LVDS Interface**

### LVPECL Output Termination

LVPECL outputs have very low output impedance (open emitter), and small signal swing which results in low EMI. LVECL is ideal for driving 50- and 100Ω-controlled impedance transmission lines. There are several techniques in terminating the LVPECL output, as shown in Figures 5a through 5c.

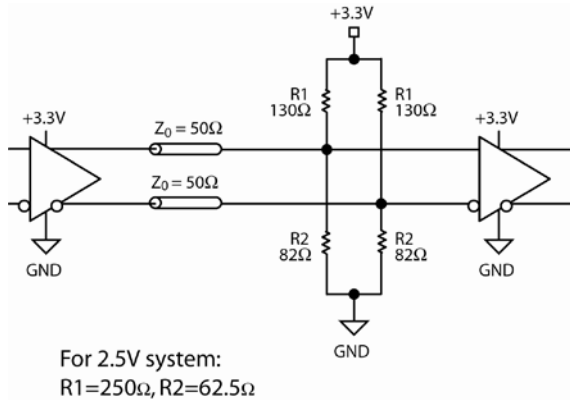


Figure 5a. Parallel Termination-Thevenin Equivalent

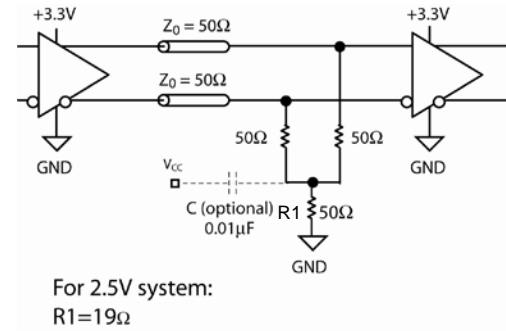
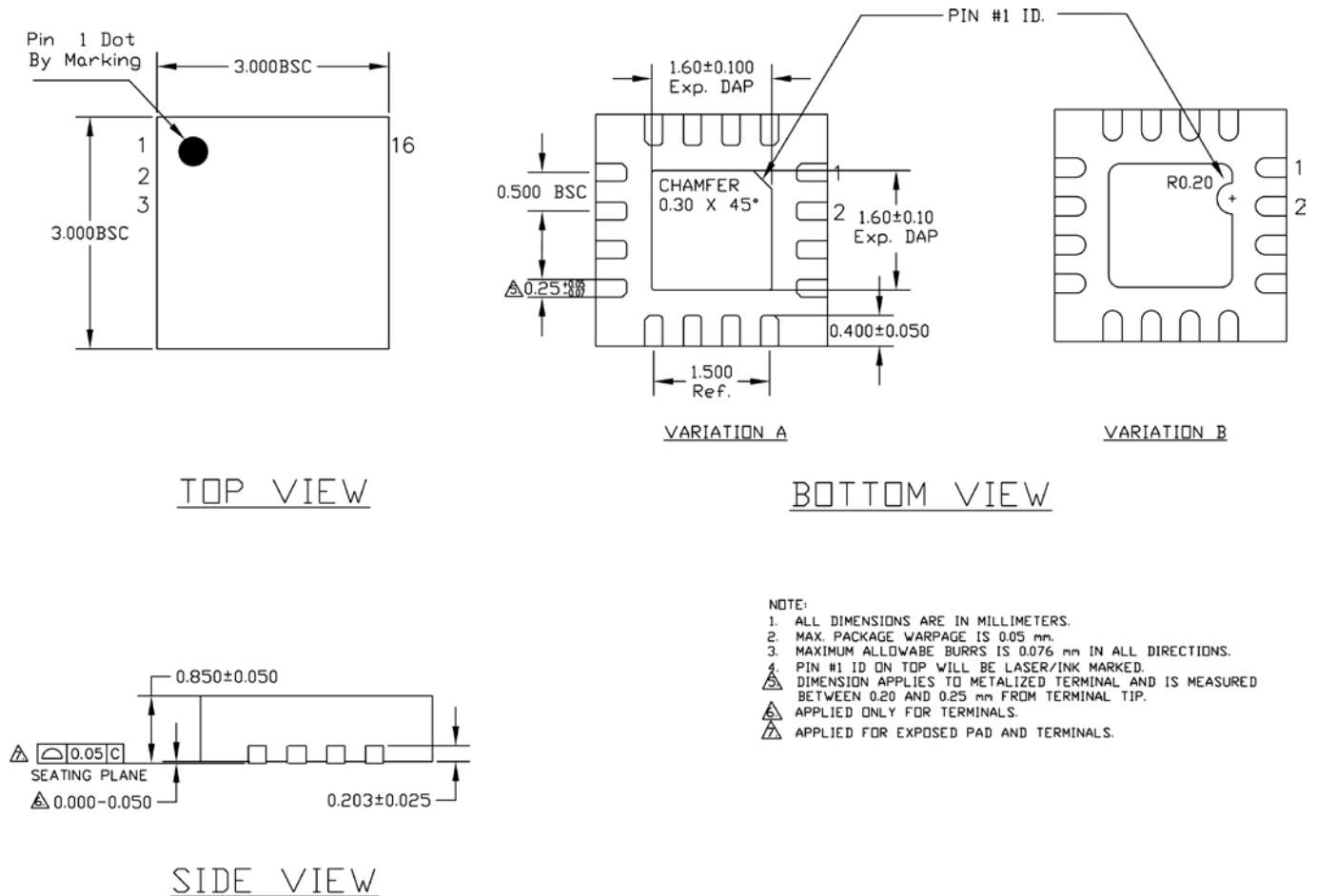


Figure 5b. Three-Resistor “Y-Termination”

### Related Product and Support Documents

Part Number	Function	Data Sheet Link
SY58606U	4.25Gbps Precision, 1:2 CML Fanout Buffer with Internal Termination and Fail Safe Input	<a href="http://www.micrel.com/page.do?page=/product-info/products/sy58606u.shtml">http://www.micrel.com/page.do?page=/product-info/products/sy58606u.shtml</a>
SY58608U	3.2Gbps Precision, 1:2 LVDS Fanout Buffer Buffer with Internal Termination and Fail Safe Input	<a href="http://www.micrel.com/page.do?page=/product-info/products/sy58608u.shtml">http://www.micrel.com/page.do?page=/product-info/products/sy58608u.shtml</a>
HBW Solutions	New Products and Termination Application Notes	<a href="http://www.micrel.com/page.do?page=/product-info/as/HBWolutions.shtml">http://www.micrel.com/page.do?page=/product-info/as/HBWolutions.shtml</a>

### Package Information



### 16-Pin QFN

**MICREL, INC. 2180 FORTUNE DRIVE SAN JOSE, CA 95131 USA**  
 TEL +1 (408) 944-0800 FAX +1 (408) 474-1000 WEB <http://www.micrel.com>

The information furnished by Micrel in this data sheet is believed to be accurate and reliable. However, no responsibility is assumed by Micrel for its use. Micrel reserves the right to change circuitry and specifications at any time without notification to the customer.

Micrel Products are not designed or authorized for use as components in life support appliances, devices or systems where malfunction of a product can reasonably be expected to result in personal injury. Life support devices or systems are devices or systems that (a) are intended for surgical implant into the body or (b) support or sustain life, and whose failure to perform can be reasonably expected to result in a significant injury to the user. A Purchaser's use or sale of Micrel Products for use in life support appliances, devices or systems is a Purchaser's own risk and Purchaser agrees to fully indemnify Micrel for any damages resulting from such use or sale.

© 2006 Micrel, Incorporated.