

Wide Gap Optical Sensor OPB856Z

Features:

- Designed for Industrial applications
- Threaded housing (M12 X 1 TH), Nut included
- Molded connectors mates with Molex 03-06-2023 plug.
- Emitter (White) and Sensor (Black) housing color coded

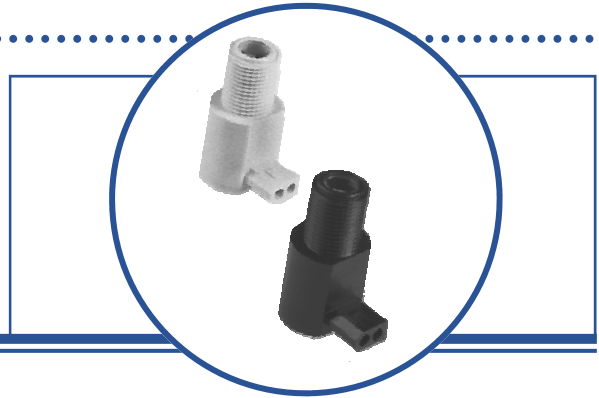

Description:

The **OPB856** emitter and sensor pair that consists of an LED (935 nm) and a Phototransistor designed to operate efficiently with each other. They are mounted in a threaded (M12x1TH) color-coded housing. The LED (white) and the Phototransistor (black) are designed to easily panel mount in through a 0.4724" (12.0 mm) hole. A 12 mm nut is included for each housing. Both components is designed to electrically mate with a Molex (03-06-2023) connector.

The OPB856 pair are designed to operate with separation distances between the LED and Phototransistor up to 12" (30.48 cm).

For Custom electrical, wire and cabling and connectors are available. Contact your local representative or OPTEK for more information.

Applications:

- Non-contact interruptive object sensing
- Assembly line automation
- Machine automation
- Equipment security
- Machine safety

Ordering Information			
Optical Pair Part Number	LED Peak Wavelength	Sensor	Connector Type
OPB856Z	935 nm	Transistor	Use Molex 03-06-2023

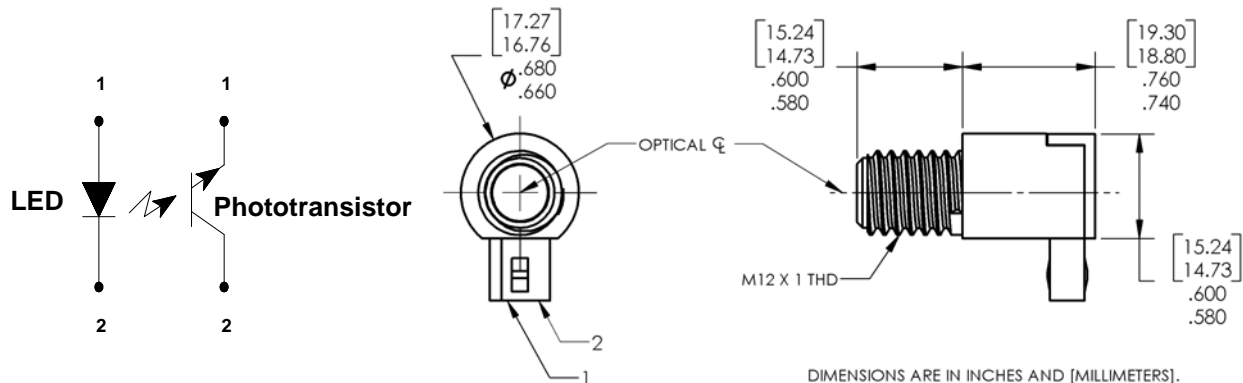

Housing	LED - White	Sensor - Black
Plug	MOLEX 03-06-2023	MOLEX 03-06-2023
Pin for Plug	Male MOLEX 02-06-6122	Female MOLEX 02-06-7104

White Housing		Black Housing	
Pin #	LED	Pin #	Phototransistor
1	Anode	1	Emitter
2	Cathode	2	Collector



RoHS

OPTEK reserves the right to make changes at any time in order to improve design and to supply the best product possible.

Absolute Maximum Ratings ($T_A=25^{\circ}\text{C}$ unless otherwise noted)

Storage & Operating Temperature Range	-40° C to +85° C
Lead Soldering Temperature [1/16 inch (1.6 mm) from case for 5 seconds with soldering iron]	260° C

Input Diode (See OP165 for additional information)

Continuous Forward DC Current	40 mA
Reverse Voltage	2 V
Power Dissipation ⁽¹⁾	100 mW

Output Phototransistor (See OP505 for additional information)

Collector-Emitter Voltage	30 V
Emitter-Collector Voltage	5 V
Power Dissipation ⁽¹⁾	100 mW

Electrical Characteristics ($T_A = 25^{\circ}\text{C}$ unless otherwise noted)

SYMBOL	PARAMETER	MIN	TYP	MAX	UNITS	TEST CONDITIONS
--------	-----------	-----	-----	-----	-------	-----------------

Input Diode (See OP9999 for additional information)

V_F	Forward Voltage	-	-	1.7	V	$I_F = 20\text{ mA}$
I_R	Reverse Current	-	-	100	μA	$V_R = 2\text{ V}$

Output Phototransistor (See OP9999 for additional information)

$V_{(BR)CEO}$	Collector-Emitter Breakdown Voltage	30	-	-	V	$I_C = 100\ \mu\text{A}$
$V_{(BR)ECO}$	Emitter-Collector Breakdown Voltage	5	-	-	V	$I_E = 100\ \mu\text{A}$
I_{CEO}	Collector Dark Current	-	-	100	nA	$V_{CE} = 10\text{ V}, I_F = 0, E_E = 0$

Combined

$I_{C(ON)}$	On-State Collector Current ⁽³⁾	1.8	-	-	mA	$V_{CE} = 5\text{ V}, I_F = 20\text{ mA}, d = 2'' (50.8\text{ mm})^{(2)}$
-------------	---	-----	---	---	----	---

Notes:

- (1) Derate linearly 1.67 mW/°C above 25 ° C..
- (2) Distance between lenses along the optical axis is "d".
- (3) All parameters tested using pulse technique.

OPTEK reserves the right to make changes at any time in order to improve design and to supply the best product possible.

Normalized Collector Current vs.
Distance between Emitter and Sensor

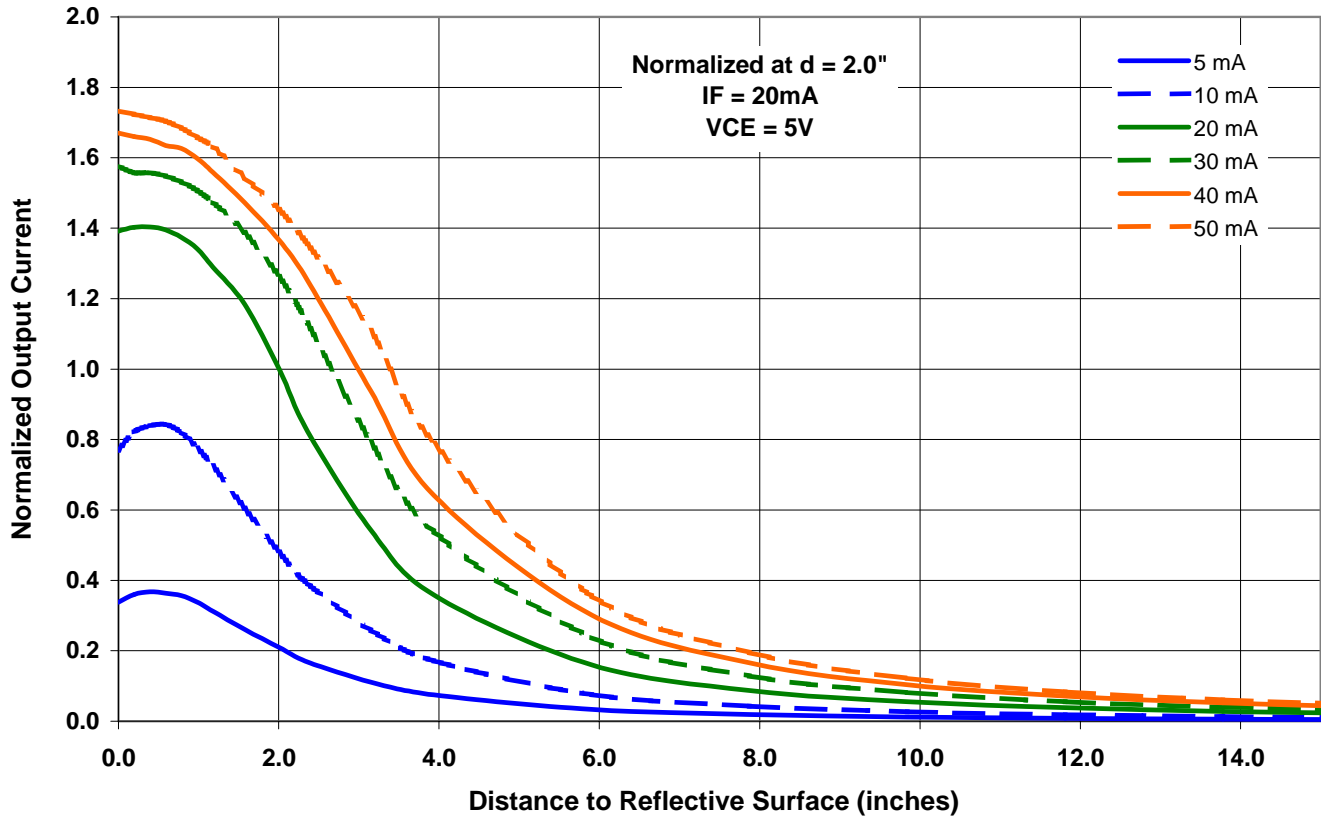

OPTEK reserves the right to make changes at any time in order to improve design and to supply the best product possible.