

0395

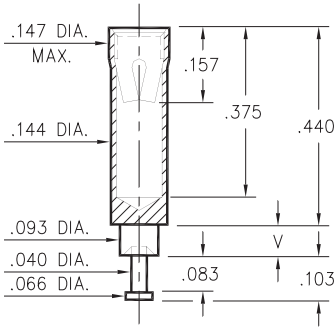

Basic Part Number	Board Thickness	Length V
0395-1	.031	.062
0395-2	.062	.094
0395-3	.094	.125
0395-4	.125	.156
0395-5	.188	.219

0395-X-15-XX-07-XX-10-0
Swage mount in .096 hole

8001

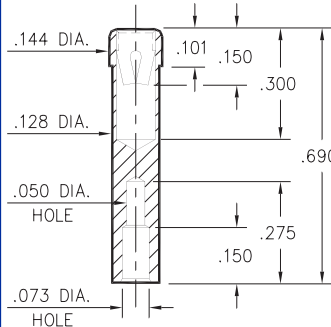

8001-0-19-XX-07-XX-10-0
Wire Termination

8016

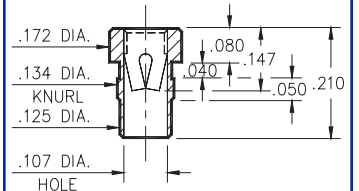

8016-0-15-XX-07-XX-10-0
Press-fit in .131 mounting hole

0350

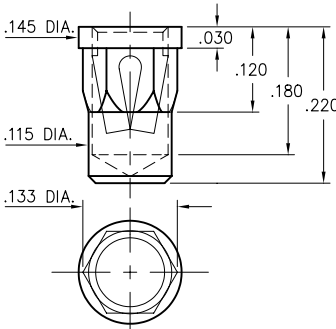

0350-0-15-XX-07-XX-10-0
Hex press-fit in .129±.002 plated thru hole

8837

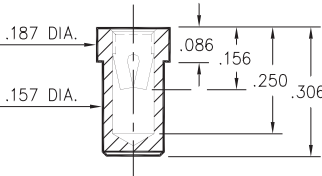

8837-0-15-XX-14-XX-10-0
Solder mount in .159 min. mounting hole

SPECIFICATIONS

SHELL MATERIAL:
Brass Alloy 360, 1/2 Hard

CONTACT MATERIAL:
Beryllium Copper Alloy 172, HT

DIMENSION IN INCHES
TOLERANCES ON:
LENGTHS: ±.005
DIAMETERS: ±.002
ANGLES: ± 2°

ORDER CODE: XXXX - X - 15 - XX - XX - XX - 10 - 0

BASIC PART # _____

SPECIFY SHELL FINISH: _____

01 200µ" TIN/LEAD OVER NICKEL
01 200µ" TIN/LEAD OVER NICKEL
15 10µ" GOLD OVER NICKEL

SPECIFY CONTACT FINISH:

01 200µ" TIN/LEAD OVER NICKEL
14 10µ" GOLD OVER NICKEL
27 30µ" GOLD OVER NICKEL

SELECT CONTACT

#07 or #14 CONTACT (DATA ON PAGES 214 & 215)