



SFP Transceiver Series (TRFxxxx)

Overview of Products

FEATURES

- **Wide Range of Applications: SDH, SONET, ATM, 155 Mbit/s to 2.5 Gbit/s, GbE, and 1GFC**
- **Variety of transmission distances: 500 m, 2 km, 15 km, 40 km, 80 km and 100 km**
- **Compliant with Small Form Factor Pluggable MSA Specification (Sept. 2000)**
- **High-Performance and Cost-Effective**
- **Compliant with Industry Standard Electrical Connector and Cage**
- **Compact Size with Industry Standard Duplex LC Connector**
- **Single + 3.3 V Power Supply and TTL Logic Interface**
- **Metal Package for Superior EMI Performance**
- **Low Power Consumption**
- **E²PROM with Serial ID Functionality**
- **Enhanced Monitoring Function (selected models)**
- **Wide Operating Temperature Range (selected models)**
- **Compliant with Class 1 Laser Product Safety Standards IEC 60825-1 and IEC 60825-2**

DESCRIPTION

General

The Small Form Factor Pluggable (SFP) series of transceiver modules from Opnext, Inc. are hot pluggable 3.3V transceivers designed for a range of high-speed bi-directional communication applications and offer nominal data rates ranging from 155 Mbit/s to 2.5 Gbit/sec. Supported distances range from 500 m (Gigabit Ethernet and Fibre Channel multimode) to 80 km (155 Mbit/s, 622 Mbit/s, 2.5 Gbit/s SONET/SDH and Gigabit Ethernet). The transceivers are compliant with all applicable standards, such as the relevant ITU and IEEE specifications, as well as the SFP Multisource Agreement (Sept. 2000). The SFP transceivers are provided with an LC receptacle that is compatible with the industry standard LC connector. The transceivers are also compatible with industry standard electrical connector and cage. The SFP transceivers are Class 1 eye safety products. The optical output power levels, under normal operation, are at eye-safe level.

SFP PRODUCT LINE OVERVIEW

Model Number*	Nominal Bit rate	Link	Application Standard
TRF542xAyLz	155 Mbit/s	15 km	OC-3 (IR-1), STM-1 (S-1.1)
TRF545xAyLz		40 km	OC-3 (LR-1), STM-1 (L-1.1)
TRF746xAyLz		80 km	OC-3 (LR-2), STM-1 (L-1.2)
TRF748xAyLz		100 km	OC-3 (LR-2), STM-1 (L-1.2), extended
TRF552xAyLz	622 Mbit/s	15 km	OC-12 (IR-1), STM-4 (S-4.1)
TRF555xAyLz		40 km	OC-12 (LR-1), STM-4 (L-4.1)
TRF756xAyLz		80 km	OC-12 (LR-2), STM-4 (L-4.2)
TRF758xAyLz		100 km	OC-12 (LR-2), STM-4 (L-4.2), extended
TRF271xAyLz	1.25 Gbit/s	550 m	GbE (1000BASE-SX)
	1.062 Gb/s	500 m	1G Fibre Channel
TRF573xAyLz	1.25 Gbit/s	10 km	GbE (1000BASE-LX)
	1.062 Gb/s	10 km	1G Fibre Channel
TRF776xAyLz	1.25 Gbit/s	80 km	GbE (1000BASE-ZX)
TRF591xAyLz	2.5 Gbit/s (optional FEC-rate support)	2 km	OC-48 (SR), STM-16 (I-16)
TRF592xAyLz		15 km	OC-48 (IR-1), STM-16 (S-16.1)
TRF595xAyLz		40 km	OC-48 (LR-1), STM-16 (L-16.1)
TRF796xAyLz		80 km	OC-48 (LR-2), STM-16 (L-16.2)

*** Meaning of “x”, “y” and “z” in product code**

- **Value of x** **Digital Diagnostic Function Implementation**

 - 5 no digital diagnostics
 - 6 with digital diagnostics
- **Value of y** **Operating Temperature Range**

 - N 0 to 70°C
 - A -5 to 70°C
 - C 0 to 75°C
 - L -5 to 75°C
 - H 0 to 85°C
 - M -5 to 85°C
 - Q -10 to 85°C
 - E -20 to 85°C
 - V -40 to 85°C
- **Value of z** **Latch Type**

 - T Thumb-release (button) latch mechanism
 - B Bail latch mechanism
 - R No latch mechanism (to be used in combination with an extraction tool)

Table 1: Product Overview

SFP to Host Connector Pin Assignment

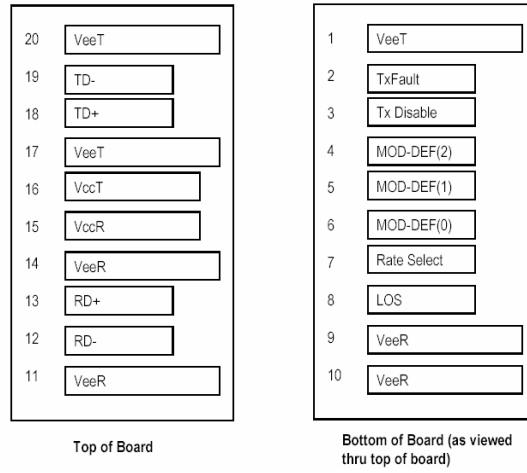

Figure 1: SFP Connector Pin Assignment

Overview of Internal Interface Signal Definition

Pin Name	Pin #	Name/Function	Signal Specification
Receiver Signals			
VeeR	9,10,11,14	Receiver Ground	Ground, to SFP Note: VeeR and VeeT are not connected internally within the SFP module
VccR	15	Receiver Power	Power, to SFP Note: VccR and VccT are the receiver and transmitter power supplies. The recommended host board power supply filtering is described below. When the recommended power supply filtering network is used, hot plugging the SFP transceiver module will result in an inrush current of no more than 30mA greater than the steady-state value. VccR and VccT are not connected internally within the SFP module
RD+ RD-	13 12	Receive Data Out Inv. Receive Data Out	High speed serial, from SFP Note: These are the differential receiver outputs. They are AC-coupled 100Ω differential lines, which should be terminated with 100Ω (differential) at the user SERDES. The AC coupling is done inside the module and thus is not required on the host board
LOS	8	Receiver Loss of Signal	Low speed, from SFP Note: This is an open collector/drain output, which should be pulled up with a 4.7 kΩ – 10 kΩ resistor. Pull-up voltage between 2.0V and VccT,R + 0.3V. When high, this output indicates the received power is below the worst-case receiver sensitivity (as defined by the standard in use). Low indicates normal operation. In the low state, the output will be pulled to <0.8V
Transmitter Signals			
VeeT	1,17,20	Transmitter Ground	Ground, to SFP Note: VeeR and VeeT are not connected internally within the SFP module
VccT	16	Transmitter Power	Power, to SFP Note: VccR and VccT are the receiver and transmitter power supplies. The recommended host board power supply filtering is described below. When the recommended power supply filtering network is used, hot plugging the SFP transceiver module will result in an inrush current of no more than 30mA greater than the steady-state value. VccR and VccT are not connected internally within the SFP module
TD+ TD-	18 19	Transmit Data In Inv. Transmit Data In	High speed serial, to SFP Note: These are the differential transmitter inputs. They are AC-coupled, differential lines, with 100Ω differential termination inside the module. The AC coupling is done inside the module and thus is not required on the host board
TX DISABLE	3	Transmitter Disable (Module disables on high or open)	Low speed, to SFP Note: Used to shut down the transmitter optical output. It is pulled up within the module with a 4.7 kΩ – 10 kΩ resistor. Its states are as follows: <ul style="list-style-type: none"> - Low (0 – 0.8V): Transmitter on - (>0.8V, <2.0V) undefined - High (2.0 – 3.465V): Transmitter disabled - Open: Transmitter disabled
TX FAULT	2	Transmitter Fault	Low speed, from SFP Note: This is an open collector/drain output, which should be pulled up with a 4.7 kΩ – 10 kΩ resistor on the host board. Pull-up voltage between 2.0V and VccT,R + 0.3V. When high, this output indicates a laser fault of some kind. Low indicates normal operation. In the low state, the output will be pulled to <0.8V
Control Signals			
MOD_DEF(0)	6	Module definition 0	These pins should be pulled up to VccT,R with a 4.7 kΩ – 10 kΩ resistor. <ul style="list-style-type: none"> - MOD_DEF(0) is grounded by the module to indicate that the module is present - MOD_DEF(1) is the clock line of the two-wire serial interface for serial ID - MOD_DEF(2) is the data line of the two-wire serial interface for serial ID
MOD_DEF(1)	5	Module definition 1	
MOD_DEF(2)	4	Module definition 2	
Rate Select	7	Select between full or reduced receiver bandwidth	N/C (not implemented, should be left open on host board)

Table 2: Overview of Internal Interface Signal Definition

Recommended Circuit Schematic

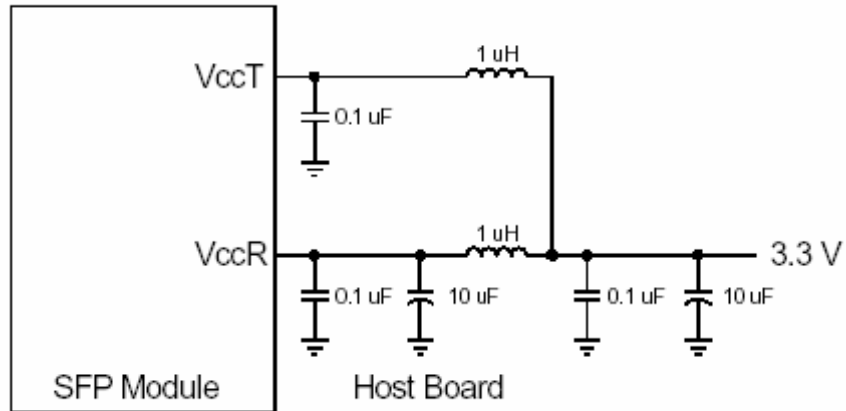
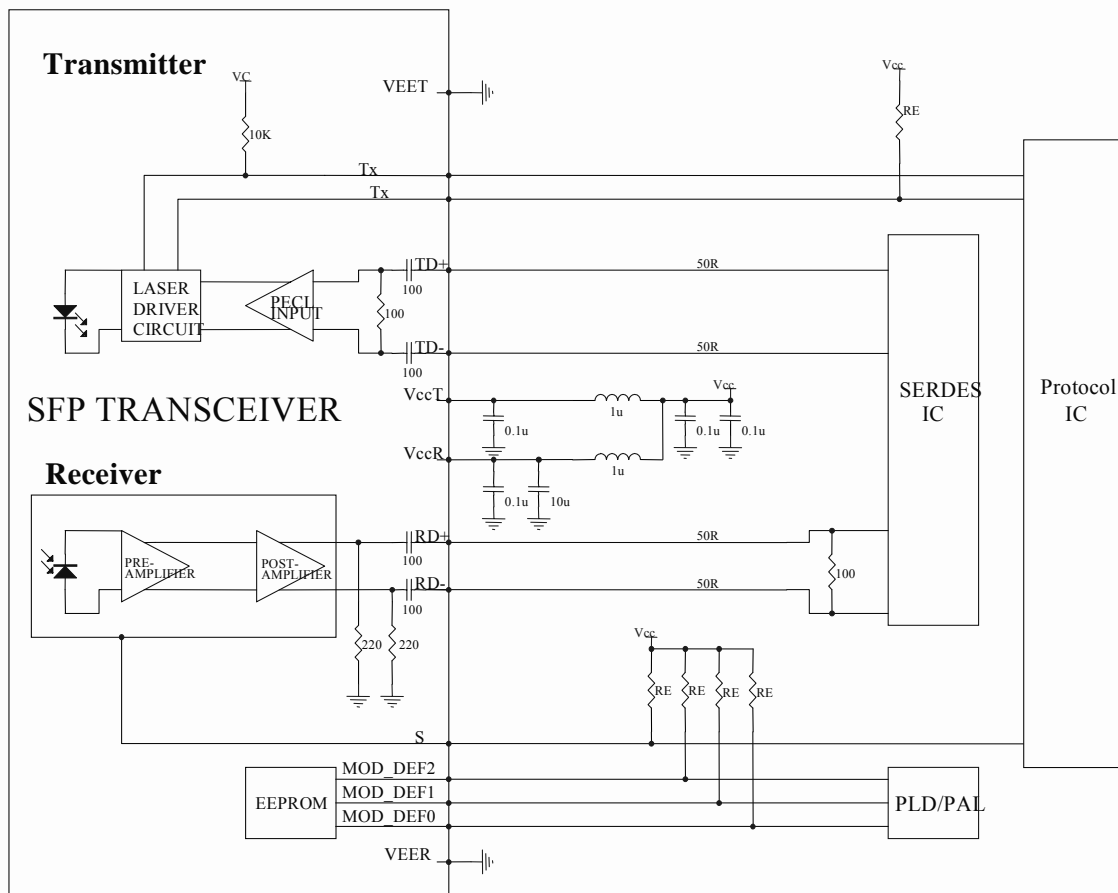

Figure 2: Recommended Host Board Supply Filtering Circuit



Note: $4.7k\Omega < RES < 10k\Omega$

Figure 3: Example Host Board Circuit Schematic

Package Outline Drawings

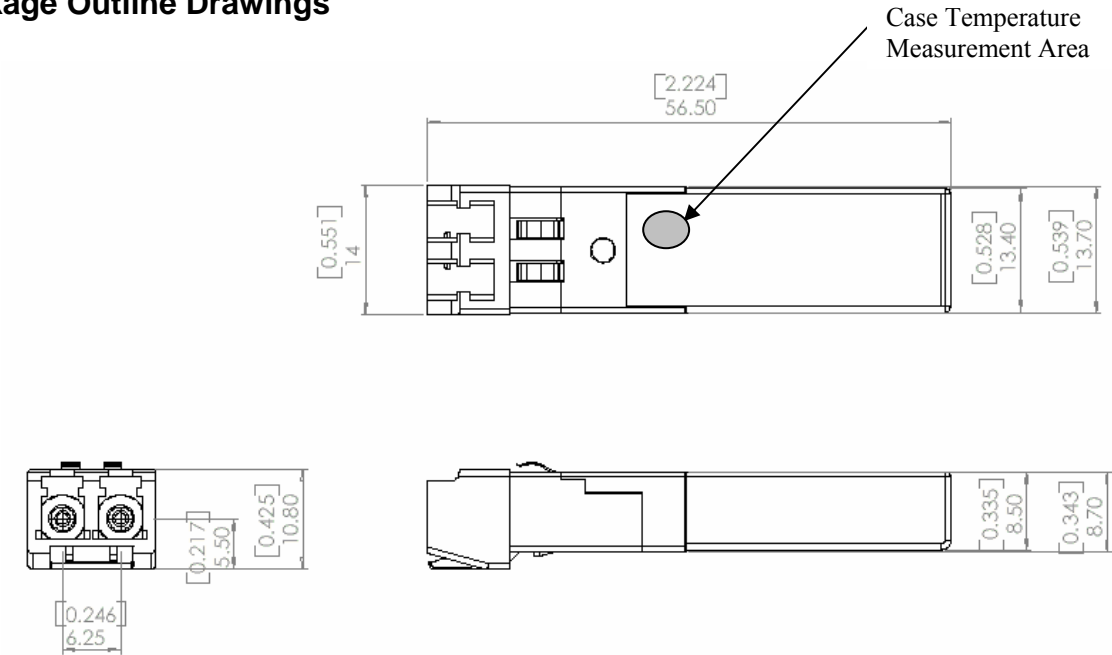

Units: mm [in]

Figure 4: Package Outline Drawing (with Thumb-Release (Button) Latch)

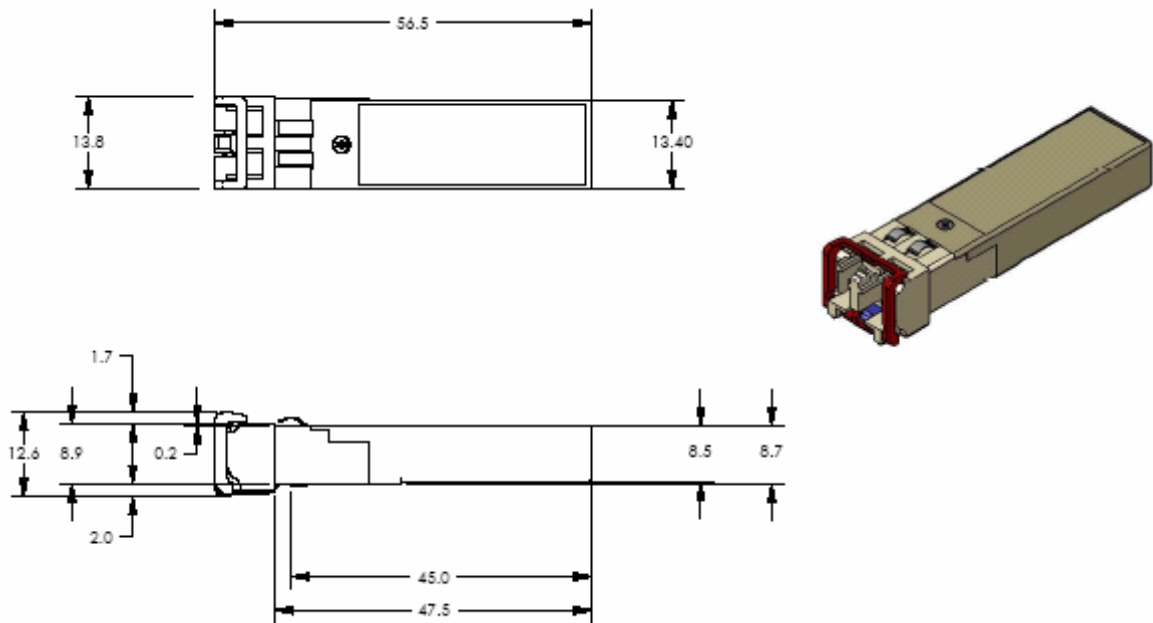
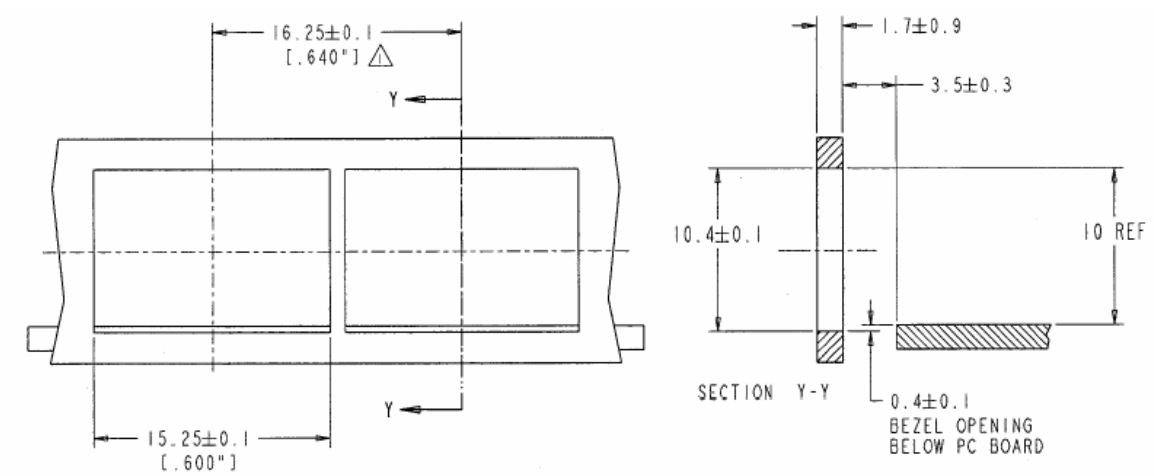

Figure 5: Package Outline Drawing (with Bail Latch)

Recommended Bezel Design



Units: mm [in]

Figure 6: Recommended Bezel Design

Digital Diagnostics (Enhanced Monitoring)

General

Some of the SFP transceivers are supplied with enhanced monitoring functions as specified per SFF-8472 (Rev 9.5 June 1, 2004). 2 wire serial bus address 1010001X (A2h) is used to access measurements of transceiver temperature, internally measured supply voltage, transmitter bias current, transmitter output power, and received optical power.

Calibration

Measurements are converted from raw A/D values to real world units using external calibration¹. Calibration constants are stored in EEPROM locations 56 – 95 at 2 wire serial bus address A2h. Calibration is valid over specified operating temperature and voltage.

Measurement Accuracy

After external calibration, the results are consistent with the accuracy and resolution goals for internally calibrated devices, as specified in SFF-8472.

Alarm and Warning Thresholds

Each A/D quantity has a corresponding high alarm, low alarm, high warning and low warning threshold. These factory-preset values allow the user to determine when a particular value is outside of normal limits. When external calibration is used, data may be compared to alarm and warning threshold values before or after calibration by the host. Comparison can be done directly before calibration. If comparison is to be done after calibration, calibration must first be applied to both data and threshold values. The values reported in the alarm and warning thresholds area may be temperature compensated or otherwise adjusted when setting warning and/or alarm flags.

¹ Internal Calibration option will be available for all codes

Parameter	Symbol	Min	Max	Unit	Conditions
TX_DISABLE Assert time	t_off		10	μsec	Time from rising edge of TX_DISABLE to when the optical output falls below 10% of nominal
TX_DISABLE Negate time	t_on		1	msec	Time from falling edge of TX_DISABLE to when the modulated optical output rises above 90% of nominal
Time to initialize, including reset of TX_FAULT	t_init		300	msec	From power on or negation of TX_Fault using TX Disable.
TX_FAULT Assert time	t_fault		100	μsec	Time from fault to TX Fault on
TX_FAULT reset time	t_reset	10		μsec	Time TX Disable must be held high to reset TX_Fault
LOS Assert Time	t_loss_on		100	μsec	Time from LOS state to Rx LOS assert
LOS Deassert Time	t_loss_off		100	μsec	Time from non-LOS state to Rx LOS deassert
Serial ID Clock Rate	f_serial_clock		100	kHz	

Table 3: Timing Parameters for SFP Management

SFP Timing Diagrams

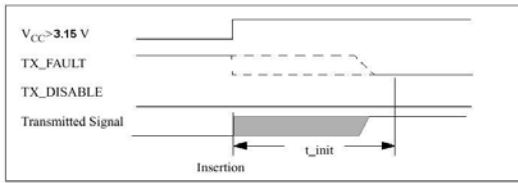

Power on initialization of SFP, TX_DISABLE negated

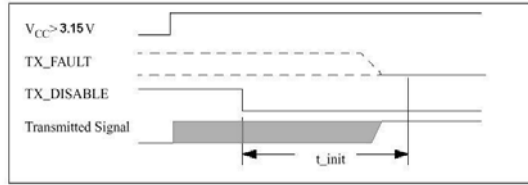

Power on initialization of SFP, TX_DISABLE asserted

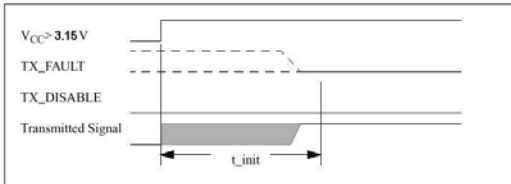

Example of initialization during hot plugging, TX_DISABLE

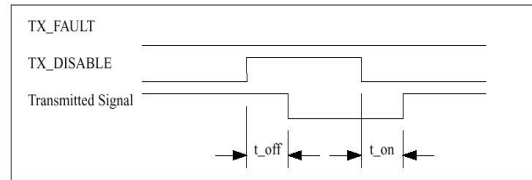

Management of SFP during normal operation, TX_DISABLE

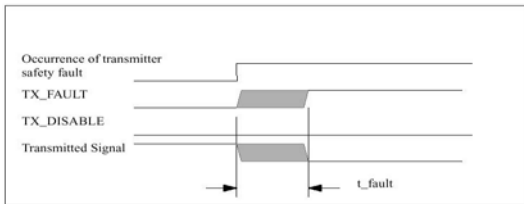

Detection of transmitter safety fault

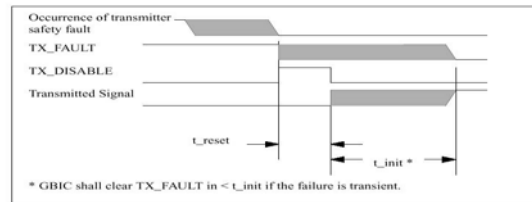

Successful recovery from transient safety fault

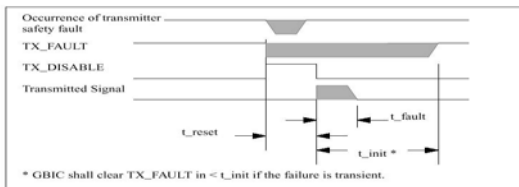

Unsuccessful recovery from safety fault

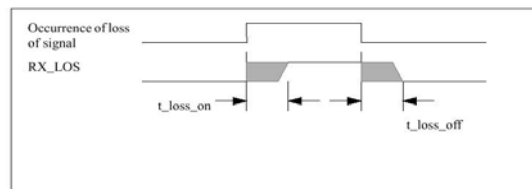

Timing of RX_LOS detection

Figure 7: SFP Timing Diagrams

Serial ID

The SFP serial ID provides access to sophisticated identification information that describe the SFP capabilities, standard interfaces, and other information. The serial interface uses the 2-wire serial CMOS E2PROM protocol defined for the ATMEL AT24C01A/02/04 family of components. The memories are organized as a series of 8-bit data words that can be addressed individually or sequentially. The 2 wire serial bus address 1010000X (A0h) is used for serial ID.

Data Address	Field Size (Bytes)	Name of field	Description of field
BASE ID FIELDS (A0h)			
0	1	Identifier	Type of serial transceiver (see Table 5)
1	1	Ext. Identifier	Extended identifier of type of serial transceiver
2	1	Connector	Code for connector type (see Table 6)
3-10	8	Transceiver	Code for electronic compatibility or optical compatibility (see Table 7)
11	1	Encoding	Code for serial encoding algorithm (see Table 9)
12	1	BR, Nominal	Nominal bit rate, units of 100 MBits/sec.
13	1	Reserved	
14	1	Length (9µm)	Link length supported for 9/125µm fiber, units of 1Km
15	1	Length (9µm)	Link length supported for 9/125µm fiber, units of 100 m
16	1	Length (50µm)	Link length supported for 50/125µm fiber, units of 10 m
17	1	Length (62.5µm)	Link length supported for 62.5/125µm fiber, units of 10 m
18	1	Length (Copper)	Link length supported for copper, units of meters
19	1	Reserved	
20-35	16	Vendor name	SFP vendor name (ASCII): OPNEXT INC
36	1	Reserved	
37-39	3	Vendor OUI	SFP vendor IEEE company ID (Hex): 00-0B-40
40-55	16	Vendor PN	Opnext part number (ASCII)
56-59	4	Vendor rev	Revision level for part number (ASCII)
60-61	2	Wavelength	Laser Wavelength
62	1	Reserved	
63	1	CC_BASE	Check code for Base ID Fields (addresses 0 to 62)
EXTENDED ID FIELDS (A0h)			
64-65	2	Options	Indicates which optional SFP signals are implemented
66	1	BR, max	Upper bit rate margin, units of %
67	1	BR, min	Lower bit rate margin, units of %
68-83	16	Vendor SN	Serial number provided by vendor (ASCII)
84-91	8	Date code	Vendor's manufacturing date code
92	1	Diagnostic Monitoring Type	Indicates which type of diagnostic monitoring is implemented (if any) in the transceiver
93	1	Enhanced Options	Indicates which optional enhanced features are implemented (if any) in the transceiver
94	1	SFF-8472 Compliance	Indicates which revision of SFF-8472 the transceiver complies with.
95	1	CC_EXT	Check code for the Extended ID Fields (addresses 64 - 94)
VENDOR SPECIFIC ID FIELDS (A0h)			
96-127	32	Read-only	Vendor specific data, read only
128-511	384	Reserved	
512-n			Vendor specific

Table 4: Serial ID Fields

Identifier

The identifier value specifies the physical device described by the serial information. This value shall be included in the serial data. The defined identifier values are shown below.

Value	Description of physical device
00h	Unknown or unspecified
01h	GBIC
02h	Module/connector soldered to motherboard
03h	SFP transceiver
03-7Fh	Reserved
80-FFh	Vendor specific

Table 5: Transceiver Type Codes

Extended Identifier

The field should be set to 04h for all SFP modules indicating serial ID module definition.

Connector

The connector value indicates the external connector provided on the interface. This value shall be included in the serial data. The defined connector values are shown below. Note that 01h-05h are not SFP compatible, but are included here for compatibility with GBIC standards.

Value	Description of Connector
00h	Unknown or unspecified.
01h	SC
02h	Fibre channel Style 1 copper connector
03h	Fibre channel Style 2 copper connector
04h	BNC/TNC
05h	Fibre channel coaxial headers
06h	Fiber Jack
07h	LC
08h	MTRJ
09h	MU
0Ah	SG
0Bh	Optical Pigtail
0C-1Fh	Reserved
20h	HSSDCII
21h	Copper Pigtail
22h-7Fh	Reserved
80-FFh	Vendor specific

Table 6: Connector Type Codes

Transceiver

The following bit significant indicators define the electronic or optical interfaces that are supported by the SFP Transceiver. At least one bit shall be set in this field. Where more than one electronic and optical interfaces are supported, the corresponding bits are also set. For Fibre Channel SFPs, the Fibre Channel speed, transmission media, transmitter technology, and distance capability shall all be specified. The defined transceiver values are shown in **Table 7** below.

Data Address	Bit	Description of transceiver	Data Address	Bit	Description of transceiver
Infiniband Compliance Codes			Fibre Channel link length		
3	7-4	Reserved	7	7	very long distance (L)
3	3	1X SX	7	6	short distance (S)
3	2	1X LX	7	5	intermediate distance (I)
3	1	1X Copper Active	7	4	long distance (L)
3	0	1X Copper Passive	Fibre Channel transmitter technology		
			7	3-2	Reserved
SONET Compliance Codes			7	1	Longwave laser (LC)
4	7-5	Reserved	7	0	Electrical inter-enclosure (EL)
4	4	SONET reach specifier bit 1 (see Table 8)	8	7	Electrical intra-enclosure (EL)
4	3	SONET reach specifier bit 2 (see Table 8)	8	6	Shortwave laser w/o OFC (SN)
4	2	OC 48, long reach	8	5	Shortwave laser w/ OFC (SL)
4	1	OC 48, intermediate reach	8	4	Longwave laser(LL)
4	0	OC 48 short reach	8	0-3	Reserved
5	7	Reserved			
5	6	OC 12, single mode long reach	Fibre Channel transmission media		
5	5	OC 12, single mode intermediate reach	9	7	Twin Axial Pair (TW)
5	4	OC 12 multi-mode short reach	9	6	Shielded Twisted Pair (TP)
5	3	Reserved	9	5	Miniature Coax (MI)
5	2	OC 3, single mode long reach	9	4	Video Coax (TV)
5	1	OC 3, single mode intermediate reach	9	3	Multi-mode, 62.5µ (M6)
5	0	OC 3, multi-mode short reach	9	2	Multi-mode, 50µ (M5)
			9	1	Reserved
Gigabit Ethernet Compliance Codes			9	0	Single Mode (SM)
6	7-4	Reserved			
6	3	1000BASE-T	Fibre Channel speed		
6	2	1000BASE-CX	10	7-5	Reserved
6	1	1000BASE-LX	10	4	400 MBytes/Sec
6	0	1000BASE-SX	10	3	Reserved
6	1,6	1000 BASE-ZX (0100 0010)	10	2	200 MBytes./Sec
			10	1	Reserved
			10	0	100 MBytes./Sec

Note: Bit 7 is the high order bit and is transmitted first in each byte.

Table 7: Electronic and Optical Compatibility Codes

SONET Compliance Codes

The SONET compliance code bits allow the host to determine with which specifications a SONET transceiver complies. For each bit rate defined in **Table 8** (OC-3, OC-12, OC-48), SONET specifies short reach (SR), intermediate reach (IR), and long reach (LR) requirements. For each of the three bit rates, a single short reach (SR) specification is defined. Two variations of intermediate reach (IR-1, IR-2) and three variations of long reach (LR-1, LR-2, and LR-3) are also defined for each bit rate.

Speed	Reach	Specifier bit 1	Specifier bit 2	Description
OC-3/OC-12/OC-48	Short	0	0	SONET SR compliant
OC-3/OC-12/OC-48	Intermediate	1	0	SONET IR-1 compliant
OC-3/OC-12/OC-48	Intermediate	0	1	SONET IR-2 compliant
OC-3/OC-12/OC-48	Long	1	0	SONET LR-1 compliant
OC-3/OC-12/OC-48	Long	0	1	SONET LR-2 compliant
OC-3/OC-12/OC-48	Long	1	1	SONET LR-3 compliant

Table 8: SONET Compliance Specifiers

Encoding

The encoding value indicates the serial encoding mechanism that is the normal design target of the particular SFP transceiver. The value shall be contained in the serial data. The defined Encoding Values are shown in Table 9.

Code	Description of encoding mechanism
00h	Unspecified
01h	8B10B
02h	4B5B
03h	NRZ
04h	Manchester
05h-FFh	Reserved

Table 9: Encoding Algorithm Codes

REGULATORY COMPLIANCE

Test Item	Test Method	Performance
Laser Eye Safety	U.S. 21 CFR 1040.10 & 1040.11, IEC 60825-1: 1993 +A1: 1997 +A2:2001	CDRH compliant and IEC Class 1 laser safe
Electromagnetic Interference (EMI)	FCC Part 15 Subpart B, Class B, IEC/CISPR 22: 1997, (EN 55022: 1998), Class B	Noise frequency range: 30MHz to 10GHz. Target margin of 25dB below FCC-B when tested as standalone unit in MSA cage within metal enclosure, using both alternating (101010) and PRBS data patterns
Radiated Immunity	IEC 61000-4-3-1995 + A1:1998 (EN 61000-4-3)	Field strength of 3V/m RMS, from 80MHz to 1 GHz. No effect on transceiver performance is detectable between these limits.
Electrostatic Discharge to Optical Connector (ESD Immunity)	IEC 6100-4-2; 1995 +A1: 1998 (EN 61000-4-2)	Withstand discharges of 15kV with an air-discharge probe, no data loss upon ESD event
Electrostatic Discharge to the Electrical Pins	MIL-STD-883E, Method 3015.7	Human Body Model, Class 1 (>1 kV)
Component Certification	UL 60950:2000, CSA C22.2 #60950-00, IEC 60950: 1999	National and International Component Certifications
Flammability	UL 94	All materials meet requirement of UL 94V-0 minimum

Table 10: Regulatory Compliance

USER INFORMATION

Handling Precautions

CAUTION: Take proper electrostatic-discharge (ESD) precautions while handling these devices. These devices are sensitive to ESD.

Laser Safety

CAUTION: Use of controls or adjustments or performance of procedures other than those specified herein may result in hazardous radiation exposure. Furthermore, unterminated optical receptacles may emit laser radiation. Refrain from viewing with optical instruments.

PERFORMANCE SPECIFICATIONS*

Absolute Maximum Ratings

Parameter	Symbol	Min.	Max.	Unit
Storage Temperature	T _S	-40	85	°C
Supply Voltage	V _{CC}	0	3.8	V

Recommended Operating Conditions

Parameter	Symbol	Min.	Max.	Unit
Operating Case Temperature ²	T _A	-40	85	°C
Supply Voltage	V _{CC}	3.135	3.465	V
Transmitter Differential Input Voltage	V _{IN p-p}	0.5	1.2	V

Electrical Characteristics

Parameter	Symbol	Min.	Max.	Unit
Transceiver Supply Current	I _{CC}		300	mA
Power Supply Voltage	V _{CC} T	3.135	3.465	V
Input Data Voltage - Differential ³	V _{IN p-p}	0.5	1.2	V
Transmit Disable Voltage Level ⁴	V _{DIS}	2.0	V _{CC}	V
Transmit Enable Voltage Level ⁴	V _{EN}	0	0.8	V
Transmit Fault Output Voltage Level ⁴	V _{FLT_HI} V _{FLT_LO}	2.0 0	V _{CC} 0.8	V V
Power Supply Voltage	V _{CCR}	3.135	3.465	V
Data output differential voltage	V _D	0.37	1.2	V
LOS Output Voltage-High ⁴	V _{SDH}	2	V _{CC}	V
LOS Output Voltage-Low ⁴	V _{SDL}	0	0.8	V

* For typical optical output power values below -5dBm, we recommend that an Agilent 86103B DCA plug-in module (or equivalent) is used for measurement, in order to ensure sufficient sensitivity.

² The location where the operating case temperature is measured is shown in the package outline drawings on page 7

³ Differential operation is necessary for optimum performance

⁴ Please see **Table 2** (page 3) for additional details on voltage level functions

TRF 542xAyLz (OC-3 / STM-1: 15km)*

Transmitter	Symbol	Min	Max	Unit
Mean Optical Wavelength	λ	1261	1360	nm
RMS Spectral Width	$\Delta\lambda_{RMS}$	-	7.7	nm
Average Optical Output Power	P_{AVG}	-15	-8	dBm
Transmitter Disabled Average Output Power	P_{DIS}	-	-40	dBm
Extinction Ratio	ER	8.2	-	dB
ITU/SONET Mask Margin	MM	20	-	%
Jitter Generation	J_{P-P}	-	0.1	UI _{P-P}
RMS Jitter Generation	J_{RMS}	-	0.01	UI _{RMS}

Receiver	Symbol	Min	Max	Unit
Average Sensitivity (Minimum Input Power) ¹	P_{MIN}	-	-28	dBm
Average Saturation (Maximum Input Power) ¹	P_{MAX}	-8	-	dBm
Loss of Signal Assert Level	LOSA	-42	-29	dBm
Loss of Signal Deassert Level	LOSD	-42	-28.5	dBm
Loss of Signal Hysteresis	ΔLOS	0.5	3	dB

1. Measured at bit error rate (BER) of 10^{-10} , using $2^{23}-1$ PRBS test data pattern and 8.2dB extinction ratio

* This transceiver also supports transmission at the Fast Ethernet bit rate, i.e. 125 Mbit/s

TRF545xAyLz (OC-3 / STM-1: 40km)

Transmitter	Symbol	Min	Max	Unit
Mean Optical Wavelength	λ	1263	1360	nm
RMS Spectral Width	$\Delta\lambda_{RMS}$	-	3	nm
Average Optical Output Power	P_{AVG}	-5	0	dBm
Transmitter Disabled Average Output Power	P_{DIS}	-	-40	dBm
Extinction Ratio	ER	10	-	dB
Jitter Generation	J_{P-P}	-	0.1	UI _{P-P}
RMS Jitter Generation	J_{RMS}	-	0.01	UI _{RMS}

Receiver	Symbol	Min	Max	Unit
Average Sensitivity (Minimum Input Power) ¹	P_{MIN}	-	-34	dBm
Average Saturation (Maximum Input Power) ¹	P_{MAX}	-10	-	dBm
Loss of Signal Assert Level	LOSA	-45	-35	dBm
Loss of Signal Deassert Level	LOSD	-45	-34.5	dBm
Loss of Signal Hysteresis	ΔLOS	0.5	3	dB

1. Measured at bit error rate (BER) of 10^{-10} , using $2^{23}-1$ PRBS test data pattern and 10dB extinction ratio

TRF746xAyLz (OC-3 / STM-1: 80km)

Transmitter	Symbol	Min	Max	Unit
Mean Optical Wavelength	λ	1480	1580	nm
-20dB Spectral Width	$\Delta\lambda_{-20dB}$	-	1	nm
Side Mode Suppression Ratio	SMSR	30	-	dB
Average Optical Output Power	P_{AVG}	-5	0	dBm
Transmitter Disabled Average Output Power	P_{DIS}	-	-40	dBm
Extinction Ratio	ER	10	-	dB
Jitter Generation	J_{P-P}	-	0.1	UI _{P-P}
RMS Jitter Generation	J_{RMS}	-	0.01	UI _{RMS}

Receiver	Symbol	Min	Max	Unit
Average Sensitivity (Minimum Input Power) ¹	P_{MIN}	-	-34	dBm
Average Saturation (Maximum Input Power) ¹	P_{MAX}	-10	-	dBm
Reflectance (Optical Return Loss)	ORL	-	-25	dB
Loss of Signal Assert Level	LOSA	-45	-35	dBm
Loss of Signal Deassert Level	LOSD	-45	-34.5	dBm
Loss of Signal Hysteresis	ΔLOS	0.5	3	dB

1. Measured at bit error rate (BER) of 10^{-10} , using $2^{23}-1$ PRBS test data pattern and 10dB extinction ratio

TRF748xAyLz (OC-3 / STM-1: 100km)

Transmitter	Symbol	Min	Max	Unit
Mean Optical Wavelength	λ	1480	1580	nm
-20dB Spectral Width	$\Delta\lambda_{-20dB}$	-	1	nm
Side Mode Suppression Ratio	SMSR	30	-	dB
Average Optical Output Power	P_{AVG}	-3	2	dBm
Transmitter Disabled Average Output Power	P_{DIS}	-	-40	dBm
Extinction Ratio	ER	10	-	dB
Jitter Generation	J_{P-P}	-	0.1	UI _{P-P}
RMS Jitter Generation	J_{RMS}	-	0.01	UI _{RMS}

Receiver	Symbol	Min	Max	Unit
Average Sensitivity (Minimum Input Power) ¹	P_{MIN}	-	-34	dBm
Average Saturation (Maximum Input Power) ¹	P_{MAX}	-10	-	dBm
Reflectance (Optical Return Loss)	ORL	-	-25	dB
Loss of Signal Assert Level	LOSA	-45	-35	dBm
Loss of Signal Deassert Level	LOSD	-45	-34.5	dBm
Loss of Signal Hysteresis	ΔLOS	0.5	3	dB

2. Measured at bit error rate (BER) of 10^{-10} , using $2^{23}-1$ PRBS test data pattern and 10dB extinction ratio

TRF552xAyLz (Dual Rate*: OC-12 / STM-4 and OC-3 / STM-1: 15km)

Transmitter	Symbol	Min	Max	Unit
Mean Optical Wavelength	λ	1274	1356	nm
RMS Spectral Width	$\Delta\lambda_{RMS}$	-	2.5	nm
Average Optical Output Power	P_{AVG}	-15	-8	dBm
Transmitter Disabled Average Output Power	P_{DIS}	-	-40	dBm
Extinction Ratio	ER	8.2	-	dB
ITU/SONET Mask Margin	MM	20	-	%
Jitter Generation	J_{P-P}	-	0.1	UI _{P-P}
RMS Jitter Generation	J_{RMS}	-	0.01	UI _{RMS}

Receiver	Symbol	Min	Max	Unit
Average Sensitivity (Minimum Input Power) ¹	P_{MIN}	-	-28	dBm
Average Saturation (Maximum Input Power) ¹	P_{MAX}	-8	-	dBm
Loss of Signal Assert Level	LOSA	-42	-29	dBm
Loss of Signal Deassert Level	LOSD	-42	-28.5	dBm
Loss of Signal Hysteresis	ΔLOS	0.5	3	dB

1. Measured at bit error rate (BER) of 10^{-10} , using $2^{23}-1$ PRBS test data pattern and 8.2dB extinction ratio

* These transceivers meet the specifications listed on this page (OC-12 / STM-4 15km) as well as the specifications listed for OC-3 / STM-1 15km.

TRF555xAyLz (OC-12 / STM-4: 40km)

Transmitter	Symbol	Min	Max	Unit
Mean Optical Wavelength	λ	1280	1335	nm
-20dB Spectral Width	$\Delta\lambda_{-20dB}$	-	1	nm
Average Optical Output Power	P_{AVG}	-3	+2	dBm
Transmitter Disabled Average Output Power	P_{DIS}	-	-40	dBm
Extinction Ratio	ER	10	-	dB
Jitter Generation	J_{P-P}	-	0.1	UI _{P-P}
RMS Jitter Generation	J_{RMS}	-	0.01	UI _{RMS}

Receiver	Symbol	Min	Max	Unit
Average Sensitivity (Minimum Input Power) ¹	P_{MIN}	-	-28	dBm
Average Saturation (Maximum Input Power) ¹	P_{MAX}	-8	-	dBm
Reflectance (Optical Return Loss)	ORL	-	-14	dB
Loss of Signal Assert Level	LOSA	-42	-29	dBm
Loss of Signal Deassert Level	LOSD	-42	-28.5	dBm
Loss of Signal Hysteresis	ΔLOS	0.5	3	dB

1. Measured at bit error rate (BER) of 10^{-10} , using $2^{23}-1$ PRBS test data pattern and 10dB extinction ratio

TRF756xAyLz (OC-12 / STM-4: 80km)

Transmitter	Symbol	Min	Max	Unit
Mean Optical Wavelength	λ	1480	1580	nm
-20dB Spectral Width	$\Delta\lambda_{-20dB}$	-	1	nm
Side Mode Suppression Ratio	SMSR	30	-	dB
Average Optical Output Power	P_{AVG}	-3	+2	dBm
Transmitter Disabled Average Output Power	P_{DIS}	-	-40	dBm
Extinction Ratio	ER	10	-	dB
Jitter Generation	J_{P-P}	-	0.1	UI _{P-P}
RMS Jitter Generation	J_{RMS}	-	0.01	UI _{RMS}

Receiver	Symbol	Min	Max	Unit
Average Sensitivity (Minimum Input Power) ¹	P_{MIN}	-	-28	dBm
Average Saturation (Maximum Input Power) ¹	P_{MAX}	-8	-	dBm
Reflectance (Optical Return Loss)	ORL	-	-27	dB
Loss of Signal Assert Level	LOSA	-42	-29	dBm
Loss of Signal Deassert Level	LOSD	-42	-28.5	dBm
Loss of Signal Hysteresis	ΔLOS	0.5	3	dB

1. Measured at bit error rate (BER) of 10^{-10} , using $2^{23}-1$ PRBS test data pattern and 10dB extinction ratio

TRF758xAyLz (OC-12 / STM-4: 100km)

Transmitter	Symbol	Min	Max	Unit
Mean Optical Wavelength	λ	1480	1580	nm
-20dB Spectral Width	$\Delta\lambda_{-20dB}$	-	1	nm
Side Mode Suppression Ratio	SMSR	30	-	dB
Average Optical Output Power	P_{AVG}	-3	+2	dBm
Transmitter Disabled Average Output Power	P_{DIS}	-	-40	dBm
Extinction Ratio	ER	10	-	dB
Jitter Generation	J_{P-P}	-	0.1	UI _{P-P}
RMS Jitter Generation	J_{RMS}	-	0.01	UI _{RMS}

Receiver	Symbol	Min	Max	Unit
Average Sensitivity (Minimum Input Power) ¹	P_{MIN}	-	-30	dBm
Average Saturation (Maximum Input Power) ¹	P_{MAX}	-8	-	dBm
Reflectance (Optical Return Loss)	ORL	-	-27	dB
Loss of Signal Assert Level	LOSA	-42	-29	dBm
Loss of Signal Deassert Level	LOSD	-42	-28.5	dBm
Loss of Signal Hysteresis	ΔLOS	0.5	3	dB

2. Measured at bit error rate (BER) of 10^{-10} , using $2^{23}-1$ PRBS test data pattern and 10dB extinction ratio

TRF591xA*yLz (OC-48 / STM-16: 2km)

Transmitter	Symbol	Min	Max	Unit
Mean Optical Wavelength	λ	1266	1360	nm
RMS Spectral Width	$\Delta\lambda_{RMS}$	-	4	nm
Average Optical Output Power	P_{AVG}	-10	-3	dBm
Transmitter Disabled Average Output Power	P_{DIS}	-	-40	dBm
Extinction Ratio	ER	8.2	-	dB
ITU/SONET Mask Margin	MM	10	-	%
Jitter Generation	J_{P-P}	-	0.1	UI _{P-P}
RMS Jitter Generation	J_{RMS}	-	0.01	UI _{RMS}

Receiver	Symbol	Min	Max	Unit
Average Sensitivity (Minimum Input Power) ¹	P_{MIN}	-	-18	dBm
Average Saturation (Maximum Input Power) ¹	P_{MAX}	-3	-	dBm
Reflectance (Optical Return Loss) ²	ORL	-	-14	dB
Reflectance (Optical Return Loss) ²	ORL	-	-27	dB
Loss of Signal Assert Level	LOSA	-40	-19	dBm
Loss of Signal Deassert Level	LOSD	-40	-18.5	dBm
Loss of Signal Hysteresis	ΔLOS	0.5	3	dB

1. Measured at bit error rate (BER) of 10^{-10} , using $2^{23}-1$ PRBS test data pattern and 8.2dB extinction ratio
2. In order to ensure acceptable penalties due to multiple reflections for all likely system configurations, a version of this transceiver with an ORL value of -27dB can also be provided (part number: TRF591x..001). The standard version of the transceiver (guaranteed to meet an ORL value of -14dB) has the part number TRF591x..000.

* For FEC support, the "A" in the designation is replaced by "F"

TRF592xA*yLz (OC-48 / STM-16: 15km)

Transmitter	Symbol	Min	Max	Unit
Mean Optical Wavelength	λ	1260	1360	nm
-20dB Spectral Width	$\Delta\lambda_{-20dB}$	-	1	nm
Side Mode Suppression Ratio	SMSR	30	-	dB
Average Optical Output Power	P_{AVG}	-5	0	dBm
Transmitter Disabled Average Output Power	P_{DIS}	-	-40	dBm
Extinction Ratio	ER	8.2	-	dB
ITU/SONET Mask Margin	MM	10	-	%
Jitter Generation	J_{P-P}	-	0.1	UI _{P-P}
RMS Jitter Generation	J_{RMS}	-	0.01	UI _{RMS}

Receiver	Symbol	Min	Max	Unit
Average Sensitivity (Minimum Input Power) ¹	P_{MIN}	-	-18	dBm
Average Saturation (Maximum Input Power) ¹	P_{MAX}	0	-	dBm
Reflectance (Optical Return Loss) ²	ORL	-	-14	dB
Reflectance (Optical Return Loss) ²	ORL	-	-27	dB
Loss of Signal Assert Level	LOSA	-40	-19	dBm
Loss of Signal Deassert Level	LOSD	-40	-18.5	dBm
Loss of Signal Hysteresis	ΔLOS	0.5	3 ³	dB

1. Measured at bit error rate (BER) of 10^{-10} , using $2^{23}-1$ PRBS test data pattern and 8.2dB extinction ratio
2. In order to ensure acceptable penalties due to multiple reflections for all likely system configurations, a version of this transceiver with an ORL value of -27dB can also be provided (part number TRF592x...001). This version of the transceiver also has an isolator integrated in the transmitter. The standard version of the transceiver (guaranteed to meet an ORL value of -14dB) has the part number TRF592x...000.
3. For TRF592x...000, the value is 4.5

* For FEC support, the "A" in the designation is replaced by "F"

TRF595xA*yLz (OC-48 / STM-16: 40km)

Transmitter	Symbol	Min	Max	Unit
Mean Optical Wavelength	λ	1280	1335	nm
-20dB Spectral Width	$\Delta\lambda_{-20dB}$	-	1	nm
Side Mode Suppression Ratio	SMSR	30	-	dB
Average Optical Output Power	P_{AVG}	-2	+3	dBm
Transmitter Disabled Average Output Power	P_{DIS}	-	-40	dBm
Extinction Ratio	ER	8.2	-	dB
Jitter Generation	J_{P-P}	-	0.1	UI _{P-P}
RMS Jitter Generation	J_{RMS}	-	0.01	UI _{RMS}

Receiver	Symbol	Min	Max	Unit
Average Sensitivity (Minimum Input Power) ¹	P_{MIN}	-	-27	dBm
Average Saturation (Maximum Input Power) ¹	P_{MAX}	-9	-	dBm
Reflectance (Optical Return Loss)	ORL	-	-27	dB
Loss of Signal Assert Level	LOSA	-40	-28	dBm
Loss of Signal Deassert Level	LOSD	-40	-27.5	dBm
Loss of Signal Hysteresis	ΔLOS	0.5	3	dB

1. Measured at bit error rate (BER) of 10^{-10} , using $2^{23}-1$ PRBS test data pattern and 8.2dB extinction ratio

* For FEC support, the “A” in the designation is replaced by “F”

TRF796xA*yLz (OC-48 / STM-16: 80km)

Transmitter	Symbol	Min	Max	Unit
Mean Optical Wavelength	λ	1500	1580	nm
-20dB Spectral Width	$\Delta\lambda_{-20dB}$	-	1	nm
Side Mode Suppression Ratio	SMSR	30	-	dB
Average Optical Output Power	P_{AVG}	-2	+3	dBm
Transmitter Disabled Average Output Power	P_{DIS}	-	-40	dBm
Extinction Ratio	ER	8.2	-	dB
Jitter Generation	J_{P-P}	-	0.1	UI _{P-P}
RMS Jitter Generation	J_{RMS}	-	0.01	UI _{RMS}

Receiver	Symbol	Min	Max	Unit
Average Sensitivity (Minimum Input Power) ¹	P_{MIN}	-	-28	dBm
Average Saturation (Maximum Input Power) ¹	P_{MAX}	-9	-	dBm
Reflectance (Optical Return Loss)	ORL	-	-27	dB
Loss of Signal Assert Level	LOSA	-40	-29	dBm
Loss of Signal Deassert Level	LOSD	-40	-28.5	dBm
Loss of Signal Hysteresis	ΔLOS	0.5	3	dB
Maximum optical path penalty	OPP		2	dB

1. Measured at bit error rate (BER) of 10^{-10} , using $2^{23}-1$ PRBS test data pattern and 8.2dB extinction ratio

* For FEC support, the “A” in the designation is replaced by “F”

TRF271xAyLz (* 1G Fibre Channel SW & GbE-SX)

Transmitter		Symbol	Min	Max	Unit
Mean Optical Wavelength		λ	770	860	nm
RMS Spectral Width		$\Delta\lambda_{RMS}$	-	0.85	nm
Average Optical Output Power		P_{AVG}	-10	-3	dBm
Transmitter Disabled Average Output Power		P_{DIS}	-	-40	dBm
Optical Modulation Amplitude		OMA	156	-	μ W
IEEE/FC Mask Margin		MM	10	-	%
Optical Rise/Fall Time		T_R / T_F	-	300	ps
Total Transmitter Jitter ¹	1.0625 Gb/s	TJ_{TX}	-	0.26	UI
Deterministic Transmitter Jitter ¹	1.0625 Gb/s	DJ_{TX}	-	0.09	UI
Relative Intensity Noise	1.0625 Gb/s	RIN	-	-116	dB/Hz

Receiver		Symbol	Min	Max	Unit
Average Sensitivity ²	1.0625 Gb/s	P_{MIN}	-	-17	dBm
Stressed Sensitivity ³	1.0625 Gb/s	P_S	-	-14.5	dBm
Average Saturation (Maximum Input Power) ²		P_{MAX}	0	-	dBm
Optical Return Loss		ORL	12	-	dB
Loss of Signal Assert Level		LOSA	-40	-18	dBm
Loss of Signal Deassert Level		LOSD	-40	-17.5	dBm
Loss of Signal Hysteresis		Δ LOS	0.5	3	dB
Total Receiver Jitter ⁴	1.0625 Gb/s	TJ_{RX}	-	0.21	UI
Deterministic Receiver Jitter ⁴	1.0625 Gb/s	DJ_{RX}	-	0.12	UI

1. Transmitter jitter added between interoperability points δ_T and γ_T as indicated in FC-PI-2.
2. Measured at bit error rate (BER) of 10^{-12} , using 2^7-1 PRBS test data pattern and 9dB extinction ratio. Measured average sensitivity of -17dBm is equivalent to 31 μ W OMA, -15dBm is equivalent to 49 μ W OMA.
3. Measured using conformance test signal defined in FC-PI-2, Annex A.6. Measured average stressed sensitivity of -14.5dBm is equivalent to 55 μ W OMA, -12.1dBm is equivalent to 96 μ W OMA.
4. Receiver jitter added between interoperability points γ_R and δ_R as indicated in FC-PI-2.

* These transceivers meet the Fibre Channel specifications listed on this page as well as the GbE-SX specifications listed on the following page.

TRF271xAyLz (* 1G Fibre Channel SW & GbE-SX, cont'd)

Transmitter	Symbol	Min	Max	Unit
Transmitter Supply Current	I_{CCT}			mA
Mean Optical Wavelength	λ	770	860	nm
RMS Spectral Width	$\Delta\lambda_{RMS}$	-	0.85	nm
Average Optical Output Power	P_{AVG}	-9.5	-3	dBm
Transmitter Disabled Average Output Power	P_{DIS}	-	-40	dBm
Extinction Ratio	ER	9	-	dB
IEEE/FC Mask Margin	MM	20	-	%
Optical Rise/Fall Time	T_R / T_F	-	260	ps
Total Transmitter Jitter ¹	TJ_{TX}	-	227	ps
Deterministic Transmitter Jitter ¹	DJ_{TX}	-	80	ps
Relative Intensity Noise	RIN	-	-117	dB/Hz

Receiver	Symbol	Min	Max	Unit
Receiver Supply Current	I_{CCR}			mA
Average Sensitivity (Minimum Input Power) ²	P_{MIN}	-	-17	dBm
Stressed Sensitivity ³	P_S	-	-13.5	dBm
Average Saturation (Maximum Input Power) ²	P_{MAX}	0	-	dBm
Optical Return Loss	ORL	12	-	dB
Loss of Signal Assert Level	LOSA	-40	-18	dBm
Loss of Signal Deassert Level	LOSD	-40	-17.5	dBm
Loss of Signal Hysteresis	ΔLOS	0.5	6	dB
Total Receiver Jitter ⁴	TJ_{RX}	-	266	ps
Deterministic Receiver Jitter ⁴	DJ_{RX}	-	170	ps

1. Transmitter jitter measured between TP1 and TP2 as indicated in IEEE 802.3 section 38.5
2. Measured at bit error rate (BER) of 10^{-12} , using 2^7-1 PRBS test data pattern and 9dB extinction ratio.
3. Measured using conformance test signal defined in IEEE 802.3, section 38.6.11
4. Receiver jitter measured between TP3 and TP4 as indicated in IEEE 802.3 section 38.5

These transceivers meet the GbE-SX specifications listed on this page as well as the Fibre Channel specifications listed on the previous page.

TRF573xAyLz (* 1G Fibre Channel LW & GbE-LX)

Transmitter		Symbol	Min	Max	Unit
Mean Optical Wavelength		λ	1270	1355	nm
RMS Spectral Width ¹		$\Delta\lambda_{RMS}$	-	2.8	nm
Average Optical Output Power		P_{AVG}	-9.5	-3	dBm
Transmitter Disabled Average Output Power		P_{DIS}	-	-40	dBm
Extinction Ratio		ER	9	-	dB
Optical Modulation Amplitude		OMA	219	-	μ W
IEEE/FC Mask Margin		MM	10	-	%
Optical Rise/Fall Time		T_R / T_F	-	320	ps
Total Transmitter Jitter ²	1.0625 Gb/s	TJ_{TX}	-	0.26	UI
Deterministic Transmitter Jitter ²	1.0625 Gb/s	DJ_{TX}	-	0.09	UI
Relative Intensity Noise	1.0625 Gb/s	RIN	-	-116	dB/Hz

Receiver		Symbol	Min	Max	Unit
Average Sensitivity ³		P_{MIN}	-	-20.2	dBm
Saturation (Maximum Input Power) ³		P_{MAX}	-3	-	dBm
Optical Return Loss		ORL	12	-	dB
Loss of Signal Assert Level		LOSA	-40	-21	dBm
Loss of Signal Deassert Level		LOSD	-40	-20.5	dBm
Loss of Signal Hysteresis		Δ LOS	0.5	3	dB
Total Receiver Jitter ⁴	1.0625 Gb/s	TJ_{RX}	-	0.20	UI
Deterministic Receiver Jitter ⁴	1.0625 Gb/s	DJ_{RX}	-	0.13	UI

1. Meets curves in FC-PI 10.0 Figures 18 and 19, which allow trade-off between wavelength, spectral width and OMA.
2. Transmitter jitter added between interoperability points δ_T and γ_T as indicated in FC-PI-2.
3. Measured at bit error rate (BER) of 10^{-12} , using 2^7-1 PRBS test data pattern and 9dB extinction ratio. Average sensitivity of -20.2dBm is equivalent to 15 μ W OMA.
4. Receiver jitter added between interoperability points γ_R and δ_R as indicated in FC-PI-2.

* These transceivers meet the Fibre Channel specifications listed on this page as well as the GbE-LX specifications listed on the following page.

TRF573xAyLz (* 1G Fibre Channel LW & GbE-LX, cont'd)

Transmitter	Symbol	Min	Max	Unit
Transmitter Supply Current	I_{CCT}			mA
Mean Optical Wavelength	λ	1270	1355	nm
RMS Spectral Width	$\Delta\lambda_{RMS}$	-	4	nm
Average Optical Output Power	P_{AVG}	-9	-3	dBm
Transmitter Disabled Average Output Power	P_{DIS}	-	-40	dBm
Extinction Ratio	ER	9	-	dB
IEEE/FC Mask Margin	MM	20	-	%
Optical Rise/Fall Time	T_R / T_F	-	260	ps
Total Transmitter Jitter ¹	TJ_{TX}	-	227	ps
Deterministic Transmitter Jitter ¹	DJ_{TX}	-	80	ps
Relative Intensity Noise	RIN	-	-120	dB/Hz

Receiver	Symbol	Min	Max	Unit
Receiver Supply Current	I_{CCR}			mA
Average Sensitivity (Minimum Input Power) ²	P_{MIN}	-	-20	dBm
Stressed Sensitivity ³	P_S	-	-14.4	dBm
Average Saturation (Maximum Input Power) ²	P_{MAX}	-3	-	dBm
Optical Return Loss	ORL	12	-	dB
Loss of Signal Assert Level	LOSA	-	-20	dBm
Loss of Signal Deassert Level	LOSD	-	-19.5	dBm
Loss of Signal Hysteresis	ΔLOS	0.5	6	dB
Total Receiver Jitter ⁴	TJ_{RX}	-	266	ps
Deterministic Receiver Jitter ⁴	DJ_{RX}	-	170	ps

1. Transmitter jitter measured between TP1 and TP2 as indicated in IEEE 802.3 section 38.5
2. Measured at bit error rate (BER) of 10^{-12} , using 2^7-1 PRBS test data pattern and 9dB extinction ratio.
3. Measured using conformance test signal defined in IEEE 802.3, section 38.6.11
4. Receiver jitter measured between TP3 and TP4 as indicated in IEEE 802.3 section 38.5

* These transceivers meet the GbE-LX specifications listed on this page as well as the Fibre Channel specifications listed on the previous page.

TRF776xAyLz (Gigabit Ethernet 1000BASE-ZX: 80km)

Transmitter	Symbol	Min	Max	Unit
Mean Optical Wavelength	λ	1530	1580	nm
-20dB Spectral Width	$\Delta\lambda_{-20dB}$	-	1	nm
Side Mode Suppression Ratio	SMSR	30		dB
Average Optical Output Power	P_{AVG}	0	+5	dBm
Transmitter Disabled Average Output Power	P_{DIS}	-	-40	dBm
Extinction Ratio	ER	9	-	dB
Optical Rise/Fall Time	T_R / T_F	-	260	ps
Total Transmitter Jitter ¹	TJ_{Tx}	-	227	ps
Deterministic Transmitter Jitter ¹	DJ_{Tx}	-	80	ps
Relative Intensity Noise	RIN	-	-120	dB/Hz

Receiver	Symbol	Min	Max	Unit
Average Sensitivity (Minimum Input Power) ²	P_{MIN}	-	-24	dBm
Average Saturation (Maximum Input Power) ²	P_{MAX}	-3	-	dBm
Optical Return Loss	ORL		-27	dB
Loss of Signal Assert Level	LOSA	-40	-25	dBm
Loss of Signal Deassert Level	LOSD	-40	-24.5	dBm
Loss of Signal Hysteresis	ΔLOS	0.5	6	dB
Total Receiver Jitter ⁴	TJ_{Rx}	-	266	ps
Deterministic Receiver Jitter ⁴	DJ_{Rx}	-	170	ps

1. Transmitter jitter measured between TP1 and TP2 as indicated in IEEE 802.3 section 38.5
2. Measured at bit error rate (BER) of 10^{-12} , using 2^7-1 PRBS test data pattern and 9dB extinction ratio.
3. Measured using conformance test signal defined in IEEE 802.3, section 38.6.11
4. Receiver jitter measured between TP3 and TP4 as indicated in IEEE 802.3 section 38.5

NOMENCLATURE INFORMATION

Item	Parameter	Symbol	
(1)	Product Category	TRF: SFF and SFP	
(2)	Wavelength Category	2: 850 nm 5: 1310 nm 7: 1550 nm	
(3)	Max. Nominal Bit-rate Supported (may support multiple bit rates, please see product and/or custom specification)	3: 52 Mbit/s 4: 155 Mbit/s 5: 622 Mbit/s 6: 1.062 Gbit/s 7: 1.25 Gbit/s 8: 2.125 Gbit/s 9: 2.5 Gbit/s	
(4)	Product Code (Application/ Range)	SONET / ITU-T	IEEE or FC
		0: VSR (600m) 1: SR (2km) 2: IR (15km) 3: IR-1(20 km) 4: SR-2(25 km) 5: LR-1(40 km) 6: LR-2/(≤ 80 km) 8: VR-2/(≥ 80km)	1: (SX) 500m 2: (LX) 5km 3: (LX) 10km 6: (ZX) 80km
(5)	Product Code (Type)	Development Code (One digit) 5: SFP, No enhanced monitoring (SFF-8472) 6: SFP, With enhanced monitoring (SFF-8472)	
(6)	Wavelength	Null: non-WDM	
(7)	Product Code (Function)	A: Nominal rate F: Nominal rate with FEC support M: Multi-Rate	
(8)	Operating Temperature Range	N: Normal 0 to 70 deg.C A: Low -5 to 70 deg. C C: Special 0 to 75 deg. C L: Low (extended) -5 to 75 deg. C H: Hardened 0 to 85 deg.C M: Medium -5 to 85 deg C Q: Wide -10 to 85 deg C E: Extended -20 to 85 deg. C V: Very Hardened -40 to 85 deg.C	
(9)	Optical Connector Type	L: LC (Standard) M:MU R:MT-RJ Other Connectors may be available.	
(10)	Package Type	T: SFP package with EMI shield and button latch B: SFP package with EMI shield and bail latch R: No latch provided (to be used in combination with extraction tool)	
(11)	Product Revision	n: Revision	
(12)	Waiver/Customized specification Code	00: Standard full specification	
(13)		nn: Customer Approved spec	
(14)	Product Status	M: Mechanical Sample F: Functional Sample Wn: Working Sample (n: null or Version number) Null: Mass Production	