

**PRELIMINARY DATA SHEET**

# SKY65014-70LF: InGaP Cascadable Amplifier

## LF-6 GHz

**Features**

- Broadband: LF-6 GHz
- Small signal gain: 15 dB typ. @ 2 GHz
- High output 3rd order intercept: +37 dBm typ.
- $OP_1$  dB: +18.5 dBm typ. @ 2 GHz
- Input and output impedance: 50  $\Omega$  nominal
- Single, positive DC supply voltage
- SOT-89 package
- Available lead (Pb)-free, RoHS compliant and Green MSL-1 @ 250 °C per JEDEC J-STD-020

**Applications**

- Wireless infrastructure: WLAN, HLAN, DBS, broadband, cellular base stations
- Test instrumentation
- CATV

**Description**

The SKY65014 is a general purpose, broadband amplifier fabricated from Skyworks InGaP HBT process and packaged in a SOT-89 package. The amplifier's input and output impedances are 50  $\Omega$ , which allows these amplifiers to be cascaded without external impedance matching networks. The typical -3 dB bandwidth of the SKY65014 is LF-6 GHz.

This amplifier is also available in the miniature SC-88 package (SKY65014-92LF) and the plastic micro-X package (SKY65014-214LF).

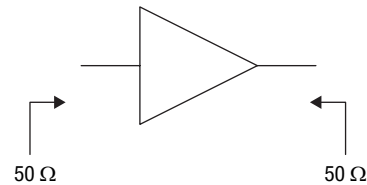
**Functional Block Diagram**

**NEW** Skyworks Green products are lead (Pb)-free, Restriction of Hazardous Substances (RoHS) compliant, conform to the EIA/EICTA/JEITA Joint Industry Guide (JIG) Level A guidelines, and are free from antimony trioxide and brominated flame retardants.



The SKY65014 is lead (Pb)-free and RoHS compliant. It is also "Green" — environmentally friendly, containing no antimony or halogens, such as bromine.

A populated evaluation board is available upon request.

Full scattering parameters for this part are available for download at [www.skyworksinc.com](http://www.skyworksinc.com)

## Electrical Specifications at 25 °C

**T = 25 °C, I<sub>S</sub> = 70 mA, P<sub>IN</sub> = 0 dBm, Z<sub>0</sub> = 50 Ω, measured in evaluation board, unless otherwise noted**

Parameter	Symbol	Condition	Frequency	Min.	Typ.	Max.	Unit
Small signal gain	GP		2 GHz	14.0	15.0	16.0	dB
3 dB gain bandwidth	BW <sub>3 dB</sub>				6.0		GHz
Noise figure	NF		2 GHz		4.5	5.0	dB
Output power at 1 dB compression	OP <sub>1 dB</sub>		2 GHz	17.0	18.5		dBm
Input and output VSWR	VSWR		0.1–5 GHz		1.9:1	2.0:1	
Output third order intercept point	OIP <sub>3</sub>	P <sub>IN</sub> = 0 dBm each tone, Δf = 10 MHz	2 GHz		37.0		dBm
Operating voltage	V <sub>D</sub>	Measured at pin 3		4.2	4.7	5.0	V
Reverse isolation	S <sub>12</sub>		0.1–6 GHz		18.0		dB
Gain flatness			10 MHz–6 GHz		±1.5		dB
Thermal resistance	θ <sub>JC</sub>				225		°C/W

## Typical Performance Data

**Z<sub>0</sub> = 50 Ω, I<sub>S</sub> = 70 mA, measured in evaluation board, unless otherwise noted**

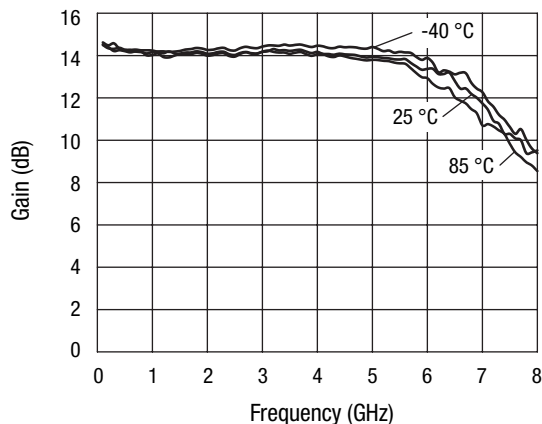

**Small Signal Gain vs. Frequency**

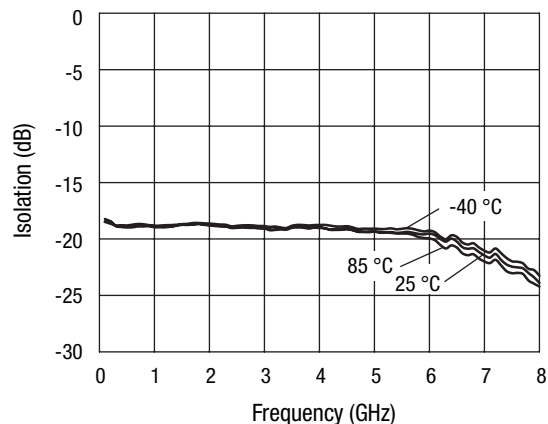

**Isolation vs. Frequency**

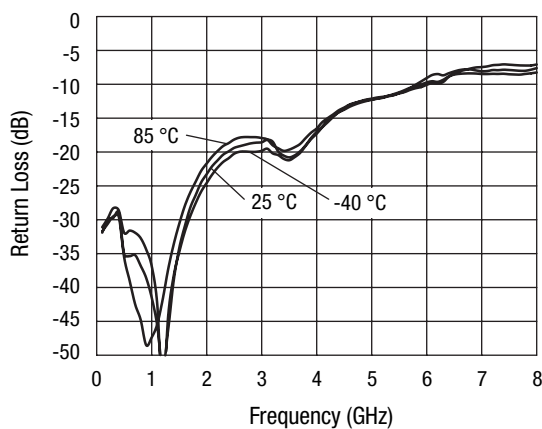

**Input Return Loss vs. Frequency**

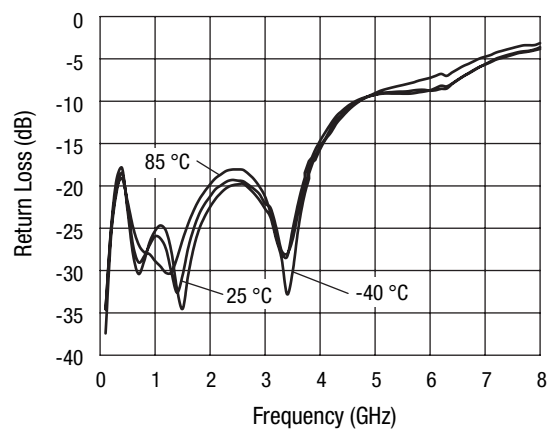

**Output Return Loss vs. Frequency**

## Absolute Maximum Ratings

Characteristic	Value
RF input power	15 dBm
Supply voltage	5 V
Supply current	120 mA
Power dissipation @ T = 25 °C	600 mW
Operating temperature	-40 °C to +85 °C
Storage temperature	-65 °C to +125 °C

Performance is guaranteed only under the conditions listed in the specifications table and is not guaranteed under the full range(s) described by the Absolute Maximum specifications. Exceeding any of the absolute maximum/minimum specifications may result in permanent damage to the device and will void the warranty.

**CAUTION:** Although this device is designed to be as robust as possible, Electrostatic Discharge (ESD) can damage this device. This device must be protected at all times from ESD. Static charges may easily produce potentials of several kilovolts on the human body or equipment, which can discharge without detection. Industry-standard ESD precautions must be employed at all times.

## SOT-89

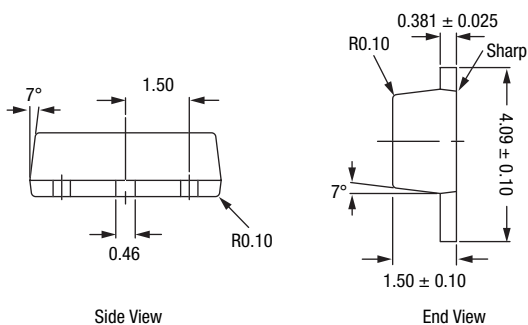

Side View

End View

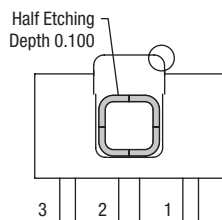

Bottom View

All measurements are in millimeters

## Pin Out (Top View)

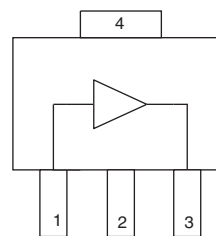

## Pin Descriptions

Pin Number	Pin Name	Description
2, 4	GND	Equipotential point – Internal circuit common, which must be connected to the PCB ground or common via the lowest possible impedance. Pin 4 must be connected via a low thermal resistance path to a good heatsink.
1	Input	RF input – RF input with 50 Ω nominal input impedance. An internally generated DC voltage is present at this pin, so an external DC block should be used to connect this pin to the external circuit.
3	Output	RF output – DC supply voltage input and RF output with 50 Ω nominal output impedance. The nominal voltage required at this pin is listed in the Electrical Specifications Table. Supply current is determined by an external resistor connected between the DC power supply and this pin.

## Evaluation Board

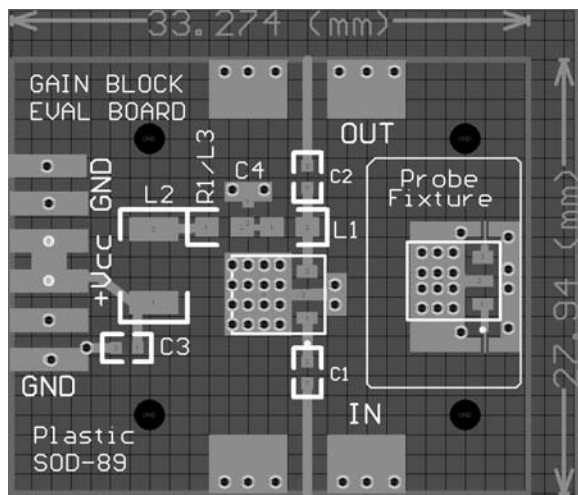
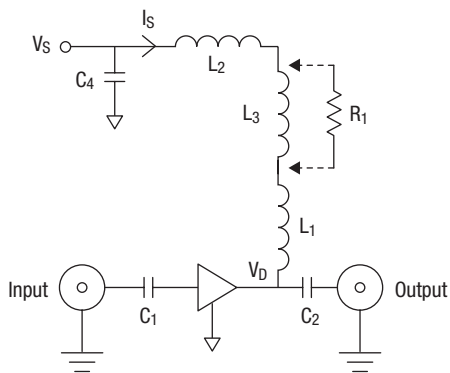

The SKY65014 evaluation board comprises the SKY65014 amplifier, the input and output of which are connected via 50  $\Omega$  microstrip transmission lines with DC blocking capacitors,  $C_1$  and  $C_2$ , to the input and output SMA connectors, respectively.

The positive supply voltage,  $V_S$ , is connected to pin 3, RF Output of the amplifier via the decoupling network which consists of  $C_4$ ,  $L_1$ ,  $L_2$  and  $R_1$ . The power supply current,  $I_S$ , must be limited, either via the current limit function of an external bench power supply, or by replacing  $L_3$  with resistor  $R_1$ , the value of which is given in the Current Limiting Resistor Values table. The evaluation board is shipped with  $L_3$  in place, which shifts an in-band series resonance of the supply decoupling network out of band. For low frequency applications,  $R_1$  may be used to conveniently limit supply current on the evaluation board.

The evaluation board also contains a probe fixtures which facilitates the direct measurement of the s parameters of the SKY65014. The probe fixture comprises a very short coplanar waveguide (CPW) transmission line to pin 1 and an identical line to pin 3. All other pins of the amplifier are grounded. The CPW transmission lines are compatible with ground-signal-ground wafer probe tips, which can be connected to the RF ports of a vector network analyzer (VNA) via coaxial cables. The very small electrical length of these CPW transmission lines obviates the need to de-embed their effects from the s parameters that are measured. The supply constant current must be applied via the bias tee, which is typically integrated into the VNA, which is cascade with the output pin of the amplifier.

## Evaluation Board Parts List

Component	Description	Value	Size	Suggested Part Number	Comments
$C_1, C_2, C_4$	Capacitor	47 nF	0603		
$L_1$	Inductor	33 nH	0603		
$L_2$	Ferrite bead			FBMH4525HM162N-T	
$R_1$	Resistor	See Current Limiting Resistor Values Table	0603		
$U_1$	Amplifier			SKY65014	

## Current Limiting Resistor Values

$V_S, V$	$R_1$ Resistance, $\Omega$	Minimum Power Dissipation rating, mW
5	4	125
6	19	125
7	33	250
8	47	500
9	61	500
10	76	500
12	104	1000

Copyright © 2002, 2003, 2004, 2005, Skyworks Solutions, Inc. All Rights Reserved.

Information in this document is provided in connection with Skyworks Solutions, Inc. ("Skyworks") products. These materials are provided by Skyworks as a service to its customers and may be used for informational purposes only by the customer. Skyworks assumes no responsibility for errors or omissions in these materials. Skyworks may make changes to its documentation, products, specifications and product descriptions at any time, without notice. Skyworks makes no commitment to update the information and shall have no responsibility whatsoever for conflicts, incompatibilities, or other difficulties arising from future changes to its documentation, products, specifications and product descriptions.

No license, express or implied, by estoppel or otherwise, to any intellectual property rights is granted by or under this document. Except as may be provided in Skyworks Terms and Conditions of Sale for such products, Skyworks assumes no liability whatsoever in association with its documentation, products, specifications and product descriptions.

THESE MATERIALS ARE PROVIDED "AS IS" WITHOUT WARRANTY OF ANY KIND, EITHER EXPRESS OR IMPLIED OR OTHERWISE, RELATING TO SALE AND/OR USE OF SKYWORKS PRODUCTS INCLUDING WARRANTIES RELATING TO FITNESS FOR A PARTICULAR PURPOSE, MERCHANTABILITY, PERFORMANCE, QUALITY OR NON-INFRINGEMENT OF ANY PATENT, COPYRIGHT OR OTHER INTELLECTUAL PROPERTY RIGHT. SKYWORKS FURTHER DOES NOT WARRANT THE ACCURACY OR COMPLETENESS OF THE INFORMATION, TEXT, GRAPHICS OR OTHER ITEMS CONTAINED WITHIN THESE MATERIALS. SKYWORKS SHALL NOT BE LIABLE FOR ANY DAMAGES, INCLUDING SPECIAL, INDIRECT, INCIDENTAL, OR CONSEQUENTIAL DAMAGES, INCLUDING WITHOUT LIMITATION, LOST REVENUES OR LOST PROFITS THAT MAY RESULT FROM THE USE OF THESE MATERIALS WHETHER OR NOT THE RECIPIENT OF MATERIALS HAS BEEN ADVISED OF THE POSSIBILITY OF SUCH DAMAGE.

Skyworks products are not intended for use in medical, lifesaving or life-sustaining applications. Skyworks customers using or selling Skyworks products for use in such applications do so at their own risk and agree to fully indemnify Skyworks for any damages resulting from such improper use or sale.

The following are trademarks of Skyworks Solutions, Inc.: Skyworks®, the Skyworks logo, and Breakthrough Simplicity®. Product names or services listed in this publication are for identification purposes only, and may be trademarks of Skyworks or other third parties. Third-party brands and names are the property of their respective owners. Additional information, posted at [www.skyworksinc.com](http://www.skyworksinc.com), is incorporated by reference.