

UNCONTROLLED DOCUMENT

PART NUMBER		REV.
OED-ST3054C16		A
REV.	E.C.N. NUMBER AND REVISION COMMENTS	DATE
A	E.C.N. #10BRDR. & REDRAWN IN 3D.	5.30.03

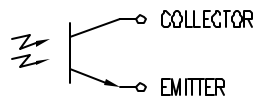
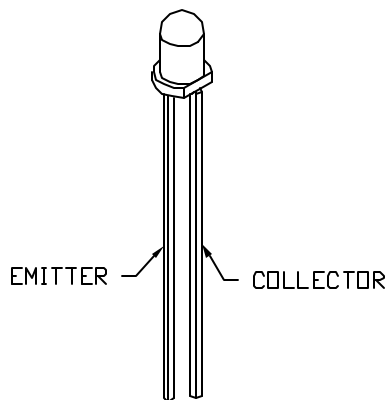
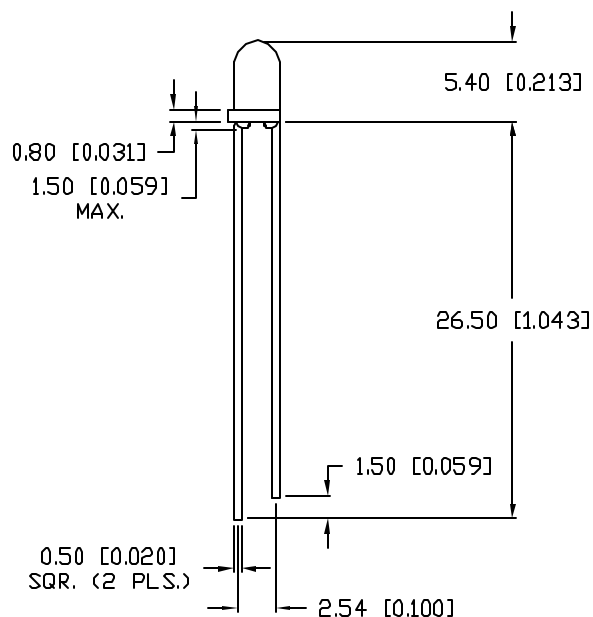
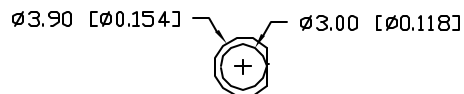

ELECTRO-OPTICAL CHARACTERISTICS $T_A=25^{\circ}\text{C}$

PARAMETER	MIN	TYP	MAX	UNITS	TEST COND
SPECTRAL SENSITIVITY		900		nm	
C/E BREAKDOWN VOLTAGE	30			V	$I_c=100\mu\text{A}$ $E_e=0.0\text{ mW/cm}^2$
E/C BREAKDOWN VOLTAGE	5.0			V	$I_c=100\mu\text{A}$ $E_e=0.0\text{ mW/cm}^2$
C/E SATURATION VOLTAGE			0.5	V	$I_c=2\text{ mA}$ $E_e=20\text{ mW/cm}^2$
COLLECTOR DARK CURRENT			100	nA	$V_{ce}=10\text{ V}$ $E_e=0.0\text{ mW/cm}^2$
COLLECTOR ON CURRENT		13		mA	$V_{ce}=5\text{ V}$ $E_e=1.0\text{ mW/cm}^2$
SWITCHING TIME		15		μS	$I_c=1\text{ mA}$ $V_{ce}=5\text{ V}, R_l=1000\Omega$
EPOXY FINISH:	WATER CLEAR				

LIMITS OF SAFE OPERATION AT 25°C

PARAMETER	MAX	UNITS
C/E BREAKDOWN VOLTAGE	30	V
E/C BREAKDOWN VOLTAGE	5	V
POWER DISSIPATION	75	mW
OPERATING TEMP.	-20 TO +70	$^{\circ}\text{C}$
STORAGE TEMP.	-30 TO +80	$^{\circ}\text{C}$
SOLDERING TEMP.	+260	$^{\circ}\text{C}$
2.0mm FROM BODY		3 SEC. MAX

*UNLESS OTHERWISE SPECIFIED TOLERANCES PER DECIMAL PRECISION ARE: X=±1 (±0.039), X.X=±0.5 (±0.020), X.XX=±0.25 (±0.010), X.XXX=±0.127 (±0.005). LEAD SIZE=±0.05 (±0.002), LEAD LENGTH=±0.75 (±0.030). MIN= ^{+0.00} _{-0.00} DECIMAL PRECISION MAX.= ^{+0.00} _{-0.00} DECIMAL PRECISION

UNCONTROLLED DOCUMENT

REV.	PART NUMBER
A	OED-ST3054C16
3mm PHOTO TRANSISTOR, WATER CLEAR LENS.	

CONFIDENTIAL INFORMATION
THE INFORMATION CONTAINED IN THIS DOCUMENT IS THE PROPERTY OF LUMEX INC. EXCEPT AS SPECIFICALLY AUTHORIZED IN WRITING BY LUMEX INC., THE HOLDER OF THIS DOCUMENT SHALL KEEP ALL INFORMATION CONTAINED HEREIN CONFIDENTIAL AND SHALL PROTECT SAME IN WHOLE OR IN PART FROM DISCLOSURE AND DISSEMINATION TO ALL THIRD PARTIES.

RELIABILITY NOTE
OUR MANY YEARS OF EXPERIENCE DATA ACCUMULATION INDICATE THAT SOLDER HEAT IS A MAJOR CAUSE OF EARLY AND FUTURE FAILURE. PLEASE PAY ATTENTION TO YOUR SOLDERING PROCESS.



290 E. HELEN ROAD
PALATINE, IL 60067-6976
PHONE: +1.847.359.2790
US WEB: www.lumex.com
TW WEB: www.lumex.com.tw

DRAWN BY:	CHECKED BY:	APPROVED BY:	DATE: 12.22.97
BC			PAGE: 1 OF 1
			SCALE: N/A