

FCN-364J*-A □ SOCKET, VERTICAL MOUNT, SOLDER DIP**

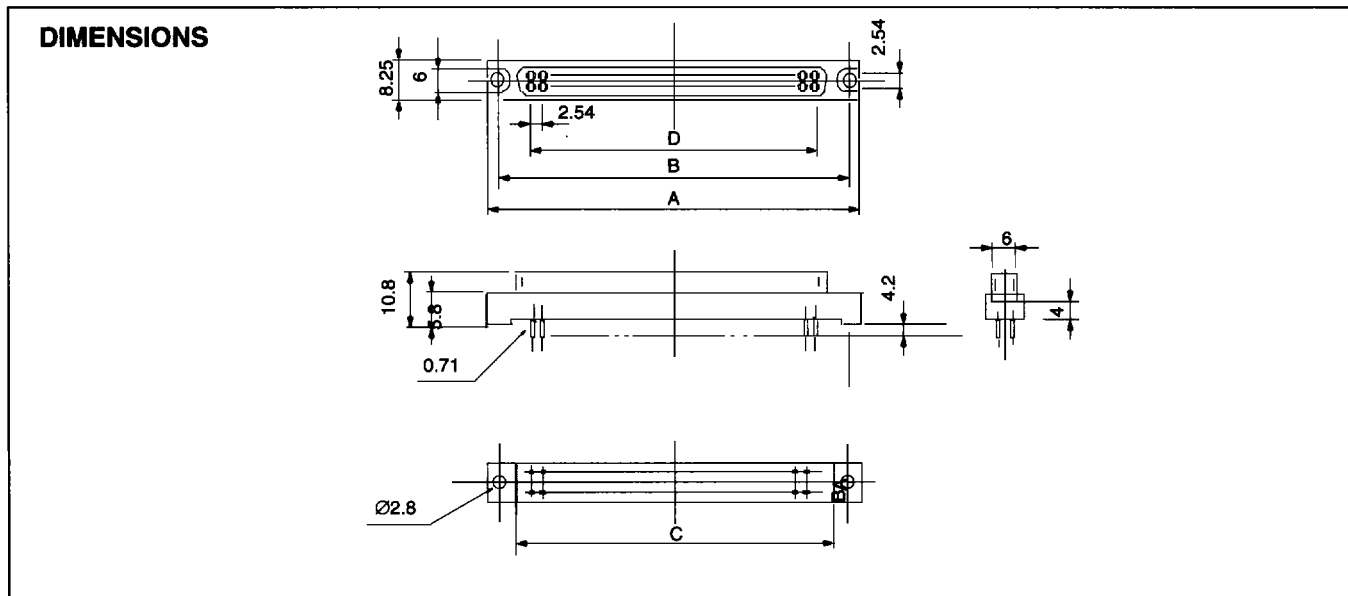

MOUNTING HOLE LAYOUT

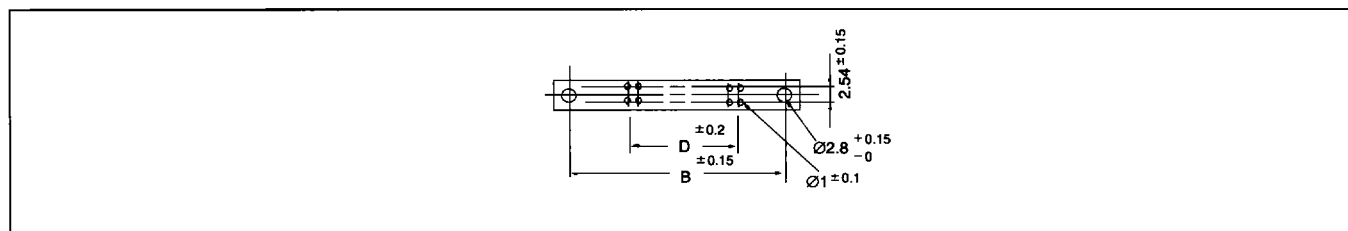

PART NUMBERS

Number of Contacts	Part numbers	Dimensions (mm)			
		A	B	C	D
8	FCN-364J008-AU	28.84	23.34	17.84	7.62
	FCN-364J008-AG				
16	FCN-364J016-AU	39.0	33.5	28.0	17.78
	FCN-364J016-AG				
24	FCN-364J024-AU	49.16	43.66	38.16	27.94
	FCN-364J024-AG				
32	FCN-364J032-AU	59.32	53.82	48.32	38.1
	FCN-364J032-AG				
40	FCN-364J040-AU	69.48	63.98	58.48	48.26
	FCN-364J040-AG				
48	FCN-364J048-AU	79.64	74.14	68.64	58.42
	FCN-364J048-AG				
56	FCN-364J056-AU	89.8	84.3	78.8	68.58
	FCN-364J056-AG				
64	FCN-364J064-AU	99.96	94.46	88.96	78.74
	FCN-364J064-AG				

Note: Designate AG for silver plating or AU for gold over palladium plating