

**IECQ-CECC**

**QC 88000-C001**

**COMPONENT**

**ISSUE 6**

**SPECIFICATION**

**March 2007**

---

**Component Specification  
For  
Ceramic Hermetically Sealed  
Transistor Optocouplers**



Up-to-date lists and bibliographical references of IECQ-CECC publications may be downloaded from [www.iecq.org](http://www.iecq.org)

Further copies of this document may be obtained from:

**IEC**

International Electrotechnical Commission  
Commission Electrotechnique Internationale

**Box 131, rue de Varembe, CH 1211 Geneva 20, Switzerland**

---

For sales enquiries, or further information, please contact our sales office at:

Isocom Ltd, Hutton Close, Crowther Industrial Estate, District 3, Washington, NE38 0AH  
Tel: +44 0191 4166 546 Fax: +44 0191 4155 055

## FOREWORD

The IECQ Quality Assessment System for Electronic Components (IECQ) is composed of those member countries of the International Electrotechnical Commission (IEC) who wish to take part in a harmonized system for electronic components of assessed quality. IECQ is also known in some European member countries as IECQ-CECC.

The object of the System is to facilitate international trade by the harmonization of the specifications and quality assessment procedures for electronic components, and by the grant of an internationally recognised Mark, or Certificate of Conformity. The components produced or services provided under the system are thereby acceptable in all member countries without further testing.

This Component Specification is based upon the requirements of IEC Publication QC 001002-2, and has been prepared by:

Isocom Ltd  
Hutton Close  
Crowther Industrial Estate  
Washington  
Tyne and Wear  
NE38 0AH  
Tel: +44 0191 4166 546  
Fax: +44 0191 4155 055

and published under the authority of:

BSI Product Services  
Maylands Avenue  
Hemel Hempstead  
Hertfordshire  
HP2 4SQ  
United Kingdom

## AMENDMENT RECORD

Issue 1 - Changed Page 10 – Amendments 25/06/10  
Issue 2 - Changed Page 4 – Amendments 22/03/10  
Issue 3 - Changed Pages 4 & 6 – Updated Drawings 25/06/10  
Issue 4 - Changed Pages 3 & 4 – Added devices IS49 & 4N49 05/07/10  
Issue 5 - Changed Pages 3, 4, 5, 6, 7 & 10 – RoHS Compliant, Added CSM165-2 & Amendments 13/07/10

## REQUIREMENTS

The requirements for IECQ-CECC Component Specifications as detailed in QC 001002-2 Amendment 1 clause 5.4 are satisfied by the following data sheet.

It should note that IECQ-CECC are not responsible for manufacturers declarations made in data sheets which fall outside the limits of approved detailed in IECQ-CECC certificates.

This Component Specification is intended for use with applicable IECQ-CECC Assessment Specifications. Eg: QC 88000-A0001

For sales enquiries, or further information, please contact our sales office at:

Isocom Ltd, Hutton Close, Crowther Industrial Estate, District 3, Washington, NE38 0AH  
Tel: +44 0191 4166 546 Fax: +44 0191 4155 055

## Ceramic Hermetically Sealed Transistor Optocouplers

- |             |            |
|-------------|------------|
| ■ 4N24      | ■ CSM1200  |
| ■ 4N49      | ■ CSM1224  |
| ■ CD500/501 | ■ CSM165-2 |
| ■ CH300     | ■ CSM165-4 |
| ■ CS200/201 | ■ CSM2224  |
| ■ CS224     | ■ IS49     |
| ■ CSM200    |            |

### Features

- Release to IECQ-CECC
- Hermetically Sealed
- High Density Packaging
- 1500V DC withstand Test Voltage
- Low Input Requirements
- High Current Transfer Ratio
- RoHS Compliant

### Applications

- Military, high reliability system
- Medical instruments
- Mos, Cmos Applications
- Logic Interfacing
- Data Transmission
- Power Supply
- Modems

### Description

These devices are single, dual and quad, hermetically sealed optocouplers. Each channel is composed of an infra-red emitting diode and a silicon phototransistor. Package styles for these devices include 6 pin, 8 pin, 16 pin flat pack, and hybrid 4 pin, with surface mount, butt cut and gull wing options available.

The same electrical die, assembly processes and materials are used for each channel of each device shown below. Therefore absolute maximum ratings, recommended operating conditions, electrical specifications and performance characteristics are identical for all units. Any exceptions, due to packaging variations and limitations, are as noted.

For sales enquiries, or further information, please contact our sales office at:

Isocom Ltd, Hutton Close, Crowther Industrial Estate, District 3, Washington, NE38 0AH  
Tel: +44 0191 4166 546 Fax: +44 0191 4155 055



## Selection Guide Package Styles and Configuration Options

Package	4 pin Hybrid	6 pin Metal Can TO-5	6 pin LCC	6 pin DIP	8 pin DIP	16 pin Flat Pack
Lead Style						
Channels	1	1	1	1	2	2/4
Common Channel Wiring						

### Isocom Part Numbers and Options

Commercial	CH300	4N24 4N49	CSM200, IS49 CSM1200/1244/2224	CS200/201 CS224	CD500 CD501	CSM165
Defense Screen Level	CH300/L2	4N24/L2 4N49/L2	CSM200/L2, IS49/L2 CSM1200/1244/2224/L2	CM200/201/L2 CS224/L2	CD500/L2 CD501/L2	CSM165/L2
Space Screen Level	CH300/L2S	4N24/L2S 4N49/L2S	CSM200/L2S, IS49/L2S CSM1200/1244/2224/L2S	CS200/201/L2S CS224/L2S	CD500/L2S CD501/L2S	CSM165/L2S
Standard Gold Plate Finish		Gold Plate	Gold Plate	Gold Plate	Gold Plate	Gold Plate
Solder Dipped				Option 20	Option 20	
Butt Cut/Gold Plate				Option 10	Option 10	
Gull Wing/Soldered				Option 30	Option 30	
Crew Cut/Gold Plate				Option 60	Option 60	

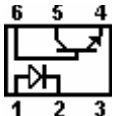
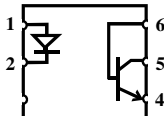
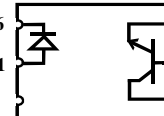
## Functional Diagrams

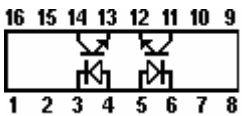
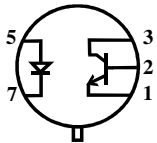
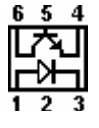
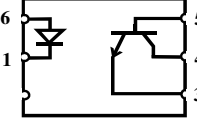
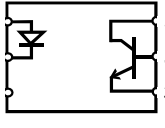
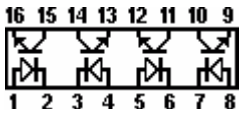
CH300	CS200/201	CSM200	CSM1224 IS49	CD500 CD501	CSM165-2
4 pin Hybrid 1 Channel	6 pin DIP 1 Channel	6 pin LCC 1 Channel	6 pin LCC 1 Channel	8 pin DIP 2 Channel	16 pin Flat Pack *2 Channel
					
<b>4N24 4N49</b>	<b>CS224</b>	<b>CSM1200</b>	<b>CSM2224</b>		<b>CSM165-4</b>
6 pin TO-5 1 Channel	6 pin DIP 1 Channel	** 6 pin LCC 1 Channel	6 pin LCC 1 Channel		16 pin Flat Pack 4 Channel
					

\* Note 2 channel is only for circuit of 2 middle channels 2 & 3 channel on the circuits.  
 \*\* See Outline Drawings 6 Terminal LCC Surface Mount, 1 Channel

For sales enquiries, or further information, please contact our sales office at:

Isocom Ltd, Hutton Close, Crowther Industrial Estate, District 3, Washington, NE38 0AH  
 Tel: +44 0191 4166 546 Fax: +44 0191 4155 055

## Outline Drawings

### 16 pin Flat Pack, 2 and 4 Channel

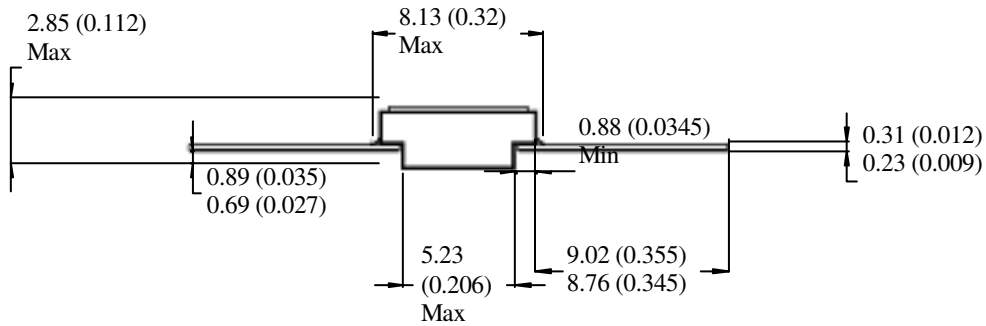
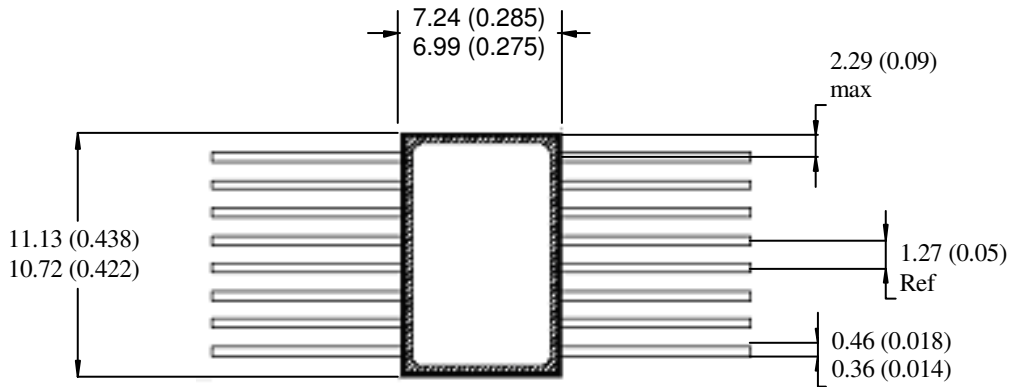

NOTE: DIMENSIONS IN MILLIMETERS

### 8 pin DIP 2 Channel

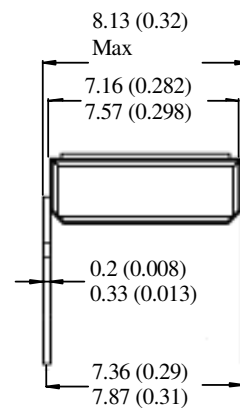
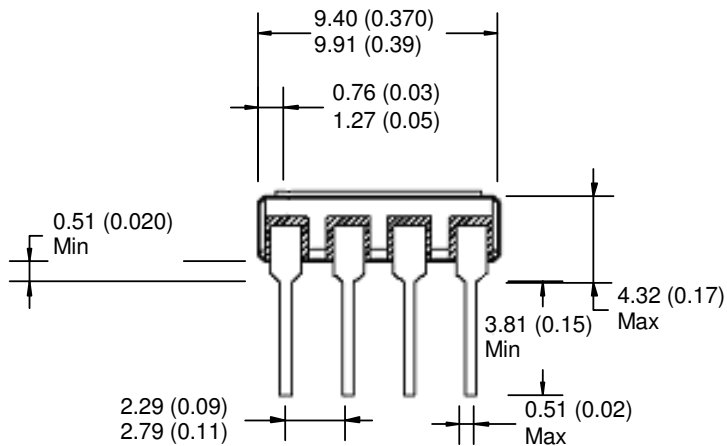

NOTE: DIMENSIONS IN MILLIMETERS

For sales enquiries, or further information, please contact our sales office at:

Isocom Ltd, Hutton Close, Crowther Industrial Estate, District 3, Washington, NE38 0AH  
 Tel: +44 0191 4166 546 Fax: +44 0191 4155 055

## 6 pin TO-5, 1 Channel

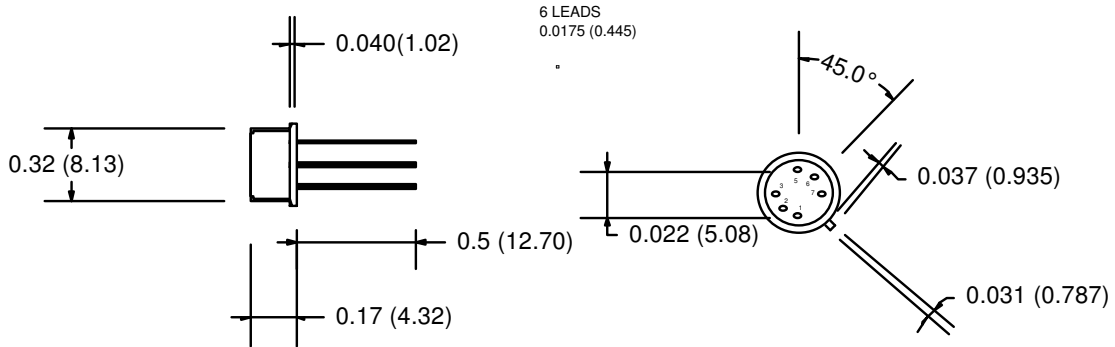

## 6 pin DIP 1 channel

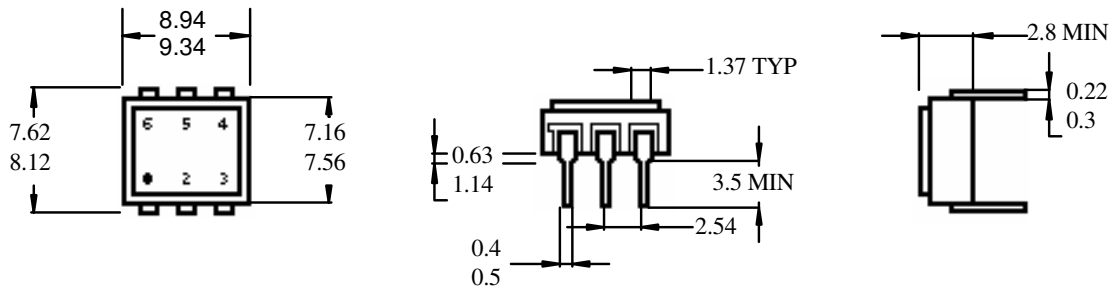

NOTE: DIMENSIONS IN MILLIMETERS

## 6 Terminal LCC Surface Mount, 1 Channel

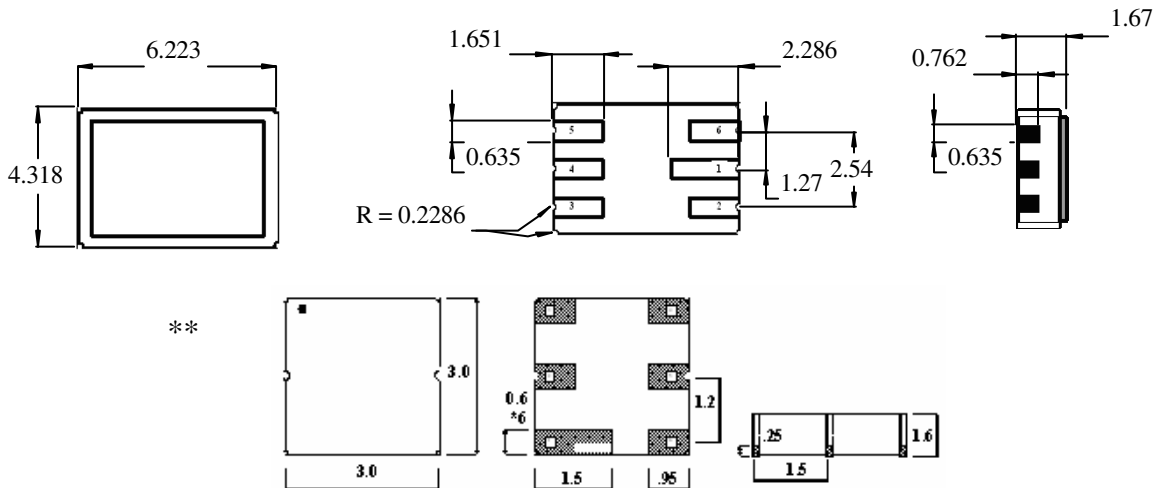

For sales enquiries, or further information, please contact our sales office at:

Isocom Ltd, Hutton Close, Crowther Industrial Estate, District 3, Washington, NE38 0AH  
Tel: +44 0191 4166 546 Fax: +44 0191 4155 055

## Device Marking

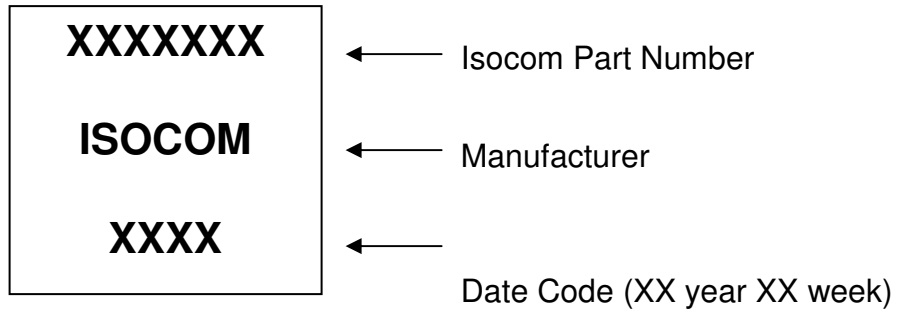

For sales enquiries, or further information, please contact our sales office at:

Isocom Ltd, Hutton Close, Crowther Industrial Estate, District 3, Washington, NE38 0AH  
Tel: +44 0191 4166 546 Fax: +44 0191 4155 055

## Hermetic Optocoupler Options

Option	Description
10	<p>Surface mountable hermetic optocoupler with leads trimmed for butt joint assembly. This option is available on commercial hi-rel product in 8 and 16 pin DIP</p>
20	
30	<p>Surface mountable hermetic optocoupler with leads cut and bent for gull wing assembly. This option is available on commercial and hi-rel product in 8 and 16 pin DIP.</p>
60	<p>Surface mountable hermetic optocoupler with leads trimmed for butt joint assembly. This option is available on commercial hi-rel product in 8 and 16 pin DIP</p>

For sales enquiries, or further information, please contact our sales office at:

Isocom Ltd, Hutton Close, Crowther Industrial Estate, District 3, Washington, NE38 0AH  
 Tel: +44 0191 4166 546 Fax: +44 0191 4155 055



## Absolute Maximum Ratings

Storage Temperature	-65 °C to +150 °C	
Operating Temperature	-55 °C to +125 °C	
Lead Soldering Temperature	260 °C 1.6mm from case for 10S	
Input-to-Output Isolation Voltage	↑1500VDC	
	↑500VDC for CH300	

## Input Diode

Forward DC Current	50mA	
	15mA	For CH300
Reverse DC Voltage	7V	
	5V	For CH300
	3V	For CSM165
	2V	For CS224
Peak forward Current	1.5mA	≤ 10µS duration
Power Dissipation	100mW	Derate linearly above 100 °C at 1.6W/°C.
	150mW	For CD500/501 and CSM165. Derate linearly above 100 °C at 1.4W/°C for CD500/501, and at 1.6 W/°C for CSM165
	25mW	For CH300

## Output Transistor

Collector-Emitter Voltage	50V	$BV_{CEO}$
	30V	For CH300
	35V	For CS224
Emitter-Collector Voltage	7V	$BV_{ECO}$
Collector-Base Voltage	70V	$BV_{CBO}$ For CS200/201 and CS224
	35V	For CS224
Collector Current	50mA	
	20mA	For CH300
Collector Current	100mA	t = 1mS
Power Dissipation	100mW	For CH300. Derate linearly above 100 °C at 1.4W/°C
	150mW	For CS200/201, CS224, CD500/501 and CSM165. Derate linearly above 100 °C at 1.4W/°C

For sales enquiries, or further information, please contact our sales office at:

Isocom Ltd, Hutton Close, Crowther Industrial Estate, District 3, Washington, NE38 0AH  
 Tel: +44 0191 4166 546 Fax: +44 0191 4155 055

## Electrical Characteristics

$T_A = 25^\circ\text{C}$  U.O.S. (each channel where appropriate).

### Input Diode Electrical Characteristics

Parameter	Symbol	Test Conditions	Device	Min	Type	Max	Units
Forward Voltage	$V_F$	$I_F = 10\text{mA}$		0.7	1.18	1.8	V (note 4)
		$I_F = 10\text{mA}, T_A = 125^\circ\text{C}$		0.7	1.10	1.8	
		$I_F = 10\text{mA}, T_A = -55^\circ\text{C}$		0.7	1.29	1.8	
Reverse Breakdown Voltage	$V_R$	$I_R = 0.1\text{mA}$		5	-	-	V
Reverse Current	$I_R$	$V_R = 3\text{V}$		-	-	100	$\mu\text{A}$
Capacitance	$C_{IN}$	$V = 0, f = 1\text{MHz}$		-	25	-	pF

### Output Detector Electrical Characteristics

Collector-Emitter Breakdown Voltage (See note 1 below)	$BV_{CEO}$	$I_C = 1\text{mA}$	CH300	40 30	-	-	V
Collector-Base Breakdown Voltage (See note 1 below)	$BV_{CBO}$	$I_B = 0.1\text{mA}$		70	-	-	V
Emitter-Collector Breakdown Voltage	$BV_{ECO}$	$I_E = 0.1\text{mA}$		7	-	-	V
Emitter-Base Breakdown Voltage	$BV_{EBO}$	$I_B = 0.1\text{mA}$		5	-	-	V
Collector-Emitter Leakage Current	$I_{CEO}$	$V_{CE} = 20\text{V}, I_F = 0$	CSM165	-	6	100	$\mu\text{A}$
		$V_{CE} = 15\text{V}, I_F = 0$		-	6	100	$\mu\text{A}$
		$V_{CE} = 20\text{V}, I_F = 0, T_A = 125^\circ\text{C}$		-	8	100	$\mu\text{A}$

### Coupled Electrical Characteristics

DC Current Transfer Ratio (See note 3)	$I_C/I_F$	$I_F = 10\text{mA}, V_{CE} = 5\text{V}$		50 100	-	-	%	
		$I_F = 10\text{mA}, V_{CE} = 5\text{V}, T_A = 125^\circ\text{C}$		CS201	50	-		-
		$I_F = 10\text{mA}, V_{CE} = 5\text{V}, T_A = -55^\circ\text{C}$		CS201	50	-		-
		$I_F = 10\text{mA}, V_{CE} = 5\text{V}; T_A = -55^\circ\text{C}-125^\circ\text{C}$			35	-		-
Optical Crosstalk	$I_{CEOX}$	$V_{CE} = 15\text{V}, I_F = 10\text{mA}$	CSM165			250	$\mu\text{A}$	
Collector-Emitter Saturation Voltage	$V_{CE}(\text{Sat})$	$I_F = 10\text{mA}, I_C = 2.5\text{mA}$		-	-	0.3	V	
		$I_F = 10\text{mA}, I_C = 10\text{mA}$	CSM165		0.4	0.9		
		$I_F = 2\text{mA}, I_C = 0.2\text{mA}$	CH300			0.25		
Input to Output Capacitance	$C_{IO}$	$V_{IO} = 0, f = 1\text{mhz}$ (See note 2 below)		-	3	5	pF	
Input to Output Resistance	$R_{IO}$	$V_{IO} = 500\text{V}$ (See note 2 below)		-	$10^{11}$	-	$\Omega$	
Isolation Voltage	$V_{IO}$	(See note 2 below)	CH300	1500 500	-	-	VDC	
Delay Time	$t_d$	$V_{CC} = 5\text{V}, I_C = 2\text{mA}$		-	4.0		$\mu\text{S}$	
Rise Time	$t_r$	$R_L = 100\text{Ohms}$		-	5.0		$\mu\text{S}$	
Storage Time	$t_s$			-	0.7		$\mu\text{S}$	
Fall Time	$t_f$			-	5.0		$\mu\text{S}$	
Turn-on Time	$t_{on}$	$V_{CC} = 5\text{V}, I_f = 5\text{mA}$		-	9		$\mu\text{S}$	
Turn-off Time	$t_{off}$	$R_L = 1\text{KOhms}$		-	25		$\mu\text{S}$	

- Notes:
- $BV_{CEO}$  and  $BV_{CBO}$  can be selected to suit customer specifications.
  - Measured between input when leads 1, 2 and 3 are shorted together and output when leads 4, 5 and 6 are shorted together.
  - A higher CTR can be selected to suit customer specification as a standard part.
  - For Radiation Tolerant  $V_F$  max = 2.0v

For sales enquiries, or further information, please contact our sales office at:

Isocom Ltd, Hutton Close, Crowther Industrial Estate, District 3, Washington, NE38 0AH  
Tel: +44 0191 4166 546 Fax: +44 0191 4155 055

## Electrical Characteristics

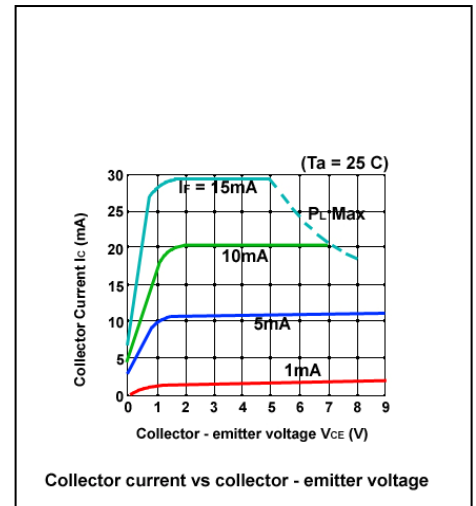
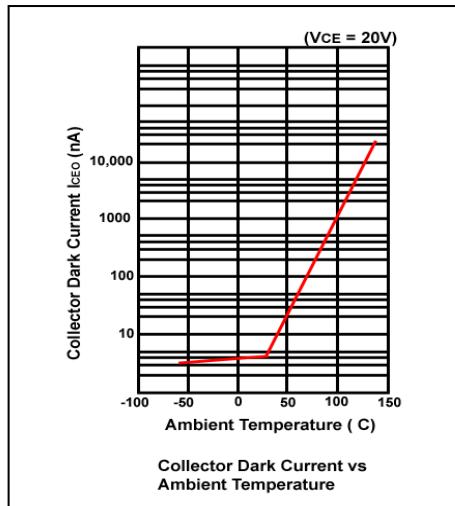
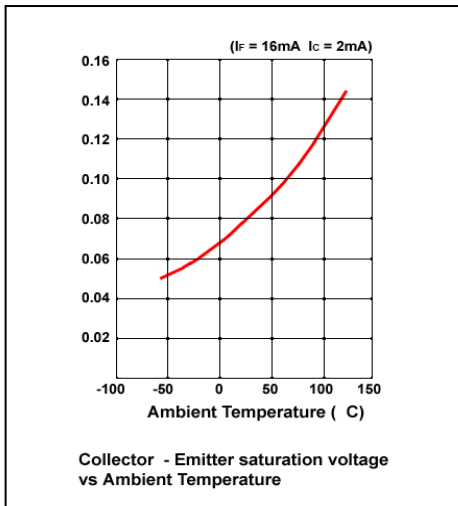
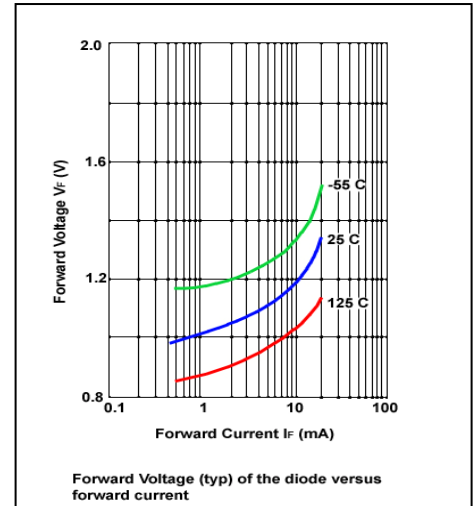
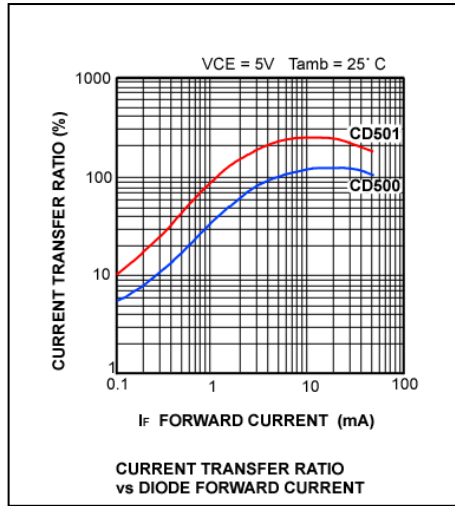
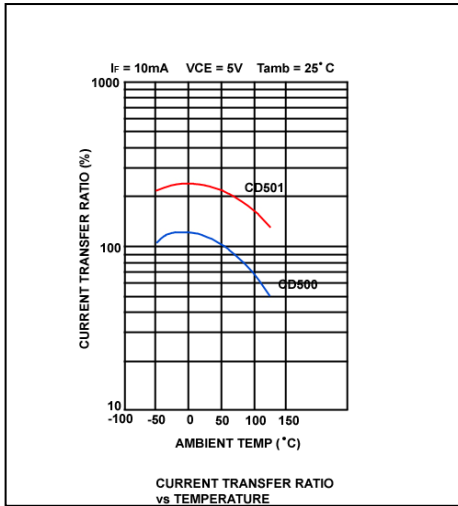

For sales enquiries, or further information, please contact our sales office at:

Isocom Ltd, Hutton Close, Crowther Industrial Estate, District 3, Washington, NE38 0AH  
 Tel: +44 0191 4166 546 Fax: +44 0191 4155 055

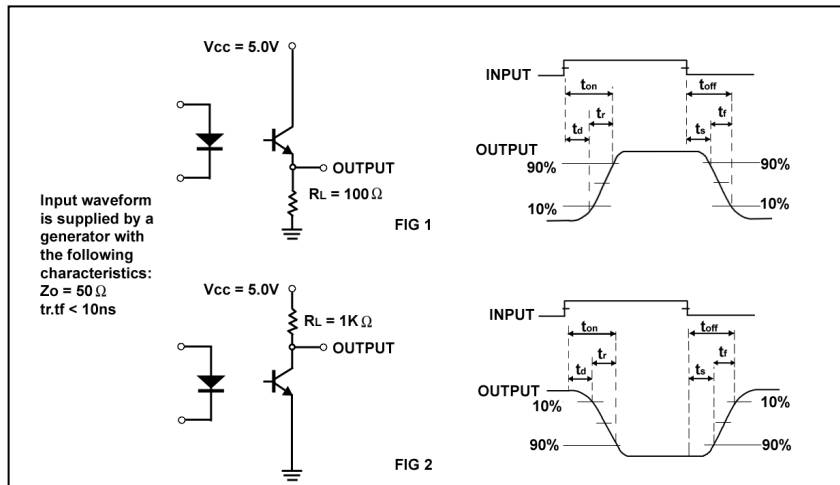

For sales enquiries, or further information, please contact our sales office at:

Isocom Ltd, Hutton Close, Crowther Industrial Estate, District 3, Washington, NE38 0AH  
 Tel: +44 0191 4166 546 Fax: +44 0191 4155 055