

CRYSTAL SPECIFICATION

Customer : 正文科技股份有限公司

Customer P/N :

Agent :

Agent Code :

SIWARD P/N : XTL571200-G47-247

Customer Approval :

希華晶體科技股份有限公司
SIWARD CRYSTAL TECHNOLOGY CO., LTD.

業務部/ SALE DEPARTMENT

TEL: (04)25347909

FAX: (04)25327885 / 25337396

URL HTTP://www.siward.com.tw

DATE : 2010/10/28

Approved By :

Cat

品質保證部/ QUALITY ASSURANCE DEPT.

TEL: (04)25347909 EXT 1340/1341

Checked By :

Tom

研發部/R & D DEPT.

TEL: (04)25347909 EXT 1533

Designer :

Sally

Address: 1-1, LANE 111, JUNG-SHAN RD., SEC.3, TANTZU HSING, TAICHUNG 427, TAIWAN, R.O.C.

Rev.	Description of Revision History	Date	Designer	Checked By
1	New Publication	2009/12/07	Scott	Tom
2	Load Capacitance Before Changed : 20 PF.(K0912-007)	2009/12/17	Sally	Tom

CRYSTAL SPECIFICATION

- 1. Description : Quartz Crystal
 - 2. Nominal Frequency : 25.000000 MHz
 - 3. Center Frequency : 25.000000 MHz
 - 4. Dimension & Drawing No. : SX-3225 ; SXD-00213
 - 5. Oscillation Mode : Fundamental
 - 6. Cutting Mode : AT cut
 - 7. Packing Style : TP-094
 - 8. Measurement Instrument : S&A 250B(Measured FL)
 - 9. Electrical Characteristics :
- [1] Operating Conditions :

Item	Symbol	MIN.	TYP.	MAX.	Unit	Condition
Operating Temperature Range	Topt	-10		95		
Storage Temperature Range	Tstg	-40		95		
Load Capacitance	CL		10		pF	
Drive Level	DL			100	μW	

[2] Frequency Stability :

Item	Symbol	MIN.	TYP.	MAX.	Unit	Condition
Tolerance	dF/Fo	-20		20	ppm	Refer to Center Frequency @25±3
Stability Over Temperature	dF/F25	-20		20	ppm	Refer to Operating Temperature
Aging	dF/F25	-3		3	ppm	Per Year

dF/Fo: Frequency Deviation Refer to Center Frequency

dF/F25: Frequency Deviation Refer to 25 Frequency

[3] Electrical Performance :

Item	Symbol	MIN.	TYP.	MAX.	Unit	Condition
Equivalent Series Resistance	ESR			60	Ω	@Series
Shunt Capacitance	Co			5	pF	
Spurious	SPDB	3			dB	@Fo+300KHz
Insulation Resistance	IR	500			M Ω	@DC 100 Volt

10. Marking : Laser

<p>*MARKING : D ->YEAR C -> MONTH YEAR : 1 2 3 4 5 6 7 8 9 0 CODE : A B C D E F G H J K MONTH: 1 2 3 4 5 6 7 8 9 10 11 12 CODE : A B C D E F G H J K L M</p>	<div style="border: 1px solid black; padding: 10px; width: fit-content; margin: auto;"> <p>25.0</p> <p>S DC</p> </div>
--	--

11. Remark :

<p>*Lead Free, RoHS compliant</p>

■ DIMENSIONS

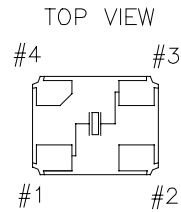
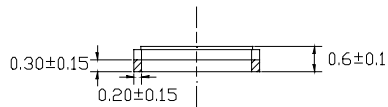
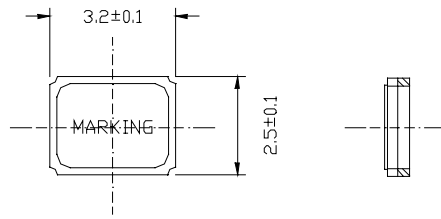

LAND PATTERN (REFERENCE)

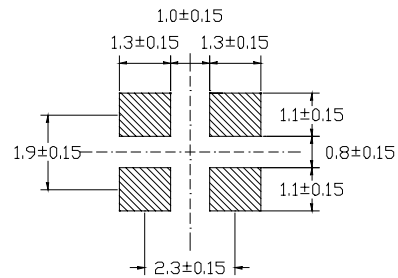
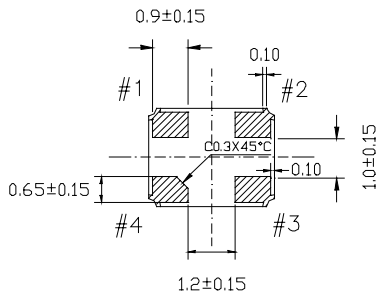

■ STRUCTURE ILLUSTRATION

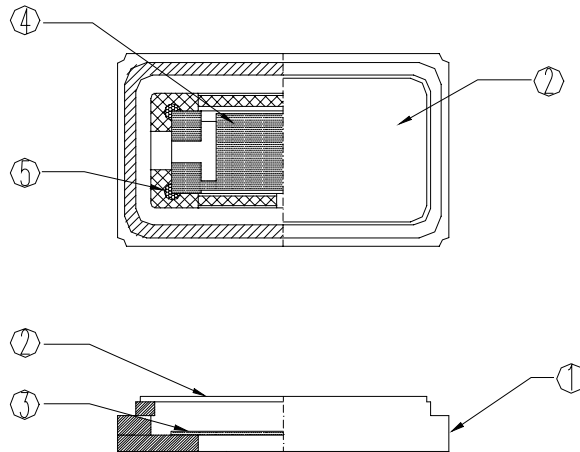

PART NAME		MATERIAL	PART NAME		MATERIAL
1.	BASE	CERAMIC	4.	ELECTRODE	Metal
2.	LID	Co	5.	ADHESMES	SILVER GLUE
3.	BLANK	QUARTZ			

■ RELIABILITY SPECIFICATION

REFER TO JIS C 6701

1. ENVIRONMENTAL PERFORMANCE

ITEM	CONDITION										
1. DRY HEAT(AGING)	STORED AT 85±2°C FOR 720±12H. THEN 25±2°C OVER 2H BEFORE TESTING.										
2. COLD	STORED AT - 40±2°C FOR 500±12H. THEN 25±2°C OVER 2H BEFORE TESTING.										
3. DAMP HEAT	STORED AT 60±2°C AND HUMIDITY 90~95% FOR 500±12 H. THEN 25±2°C OVER 2H BEFORE TESTING.										
4. TEMPERATURE CYCLE	<p>THE CRYSTAL UNIT SHALL BE SUBJECTED TO 100 SUCCESSIVE CHANGE OF TEMPERATURE CYCLES, THEN 25±2°C OVER 2H BEFORE TESTING, EACH CYCLE AS BELLOW :</p> <table style="margin-left: 40px;"> <thead> <tr> <th>TEMPERATURE</th> <th>DURATION</th> </tr> </thead> <tbody> <tr> <td>1. -40+0/-6°C</td> <td>30±3 MINUTES</td> </tr> <tr> <td>2. 25°C±2°C</td> <td>2~3 MINUTES</td> </tr> <tr> <td>3. 85+4/-0°C</td> <td>30±3 MINUTES</td> </tr> <tr> <td>4. 25°C±2°C</td> <td>2~3 MINUTES</td> </tr> </tbody> </table>	TEMPERATURE	DURATION	1. -40+0/-6°C	30±3 MINUTES	2. 25°C±2°C	2~3 MINUTES	3. 85+4/-0°C	30±3 MINUTES	4. 25°C±2°C	2~3 MINUTES
TEMPERATURE	DURATION										
1. -40+0/-6°C	30±3 MINUTES										
2. 25°C±2°C	2~3 MINUTES										
3. 85+4/-0°C	30±3 MINUTES										
4. 25°C±2°C	2~3 MINUTES										

2. MECHANICAL PERFORMANCE

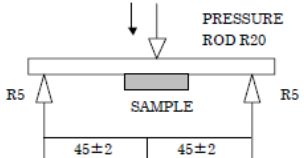
ITEM	CONDITION
5. SOLDERABILITY	THE LEAD IS IMMERSED IN A 260±5°C SOLDER BATH WITHIN 2±0.6 SECONDS.
6. RESISTANCE TO SOLDERING HEAT	REFLOW CHART AS ATTACH SHEET. TWICE PASS.
7. FREE FALL	FREE DROPPING FROM 75 cm HEIGHT 3 TIMES ON A HARD WOODEN BOARD.
8. VIBRATION	FREQUENCY : 10~55Hz, AMPLITUDE (TOTAL EXCURSION) : 1.5mm±15%, SWEEP TIME : 1MIN, 3 DIRECTION(X, Y, Z) EACH 2H.
9. SEALING	MASS-SPECTROMETER-TYPE LEAK DETECTOR SHALL BE USED TO MEASURE THE LEAKAGE RATE OF GAS THROUGH ANY FAULTY SEAL.
10. TERMINAL STRENGTH	<p>SHALL BE PRESSURIZED AT A SPEED OF APPROX.0.5mm/sec IN THE DIRECTION INDICATED BY THE ARROW UNTIL THE BENDING WIDTH REACHES 3mm AND HELD FOR 5 SECONDS.</p> 

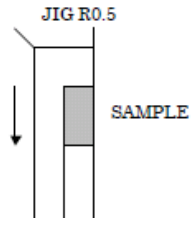
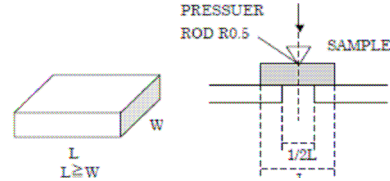
<p>11. STICKING TENDENCY</p>	<p>A R0.5 JIG SHALL BE USED TO APPLY A 10N DEAD LOAD IN THE DIRECTION INDICATED BY THE ARROW TO THE ELEMENT AND RETAIN IT FOR 10 SECONDS.</p> 
<p>12. ELEMENT ASSEMBLY STRENGTH</p>	<p>A R0.5 PRESSURIZED BAR SHALL BE USED TO APPLY A 10N LOAD IN THE CENTER OF ELEMENT AND RETAIN IT FOR 10 SECONDS.</p> 

■ SUGGESTED REFLOW PROFILE

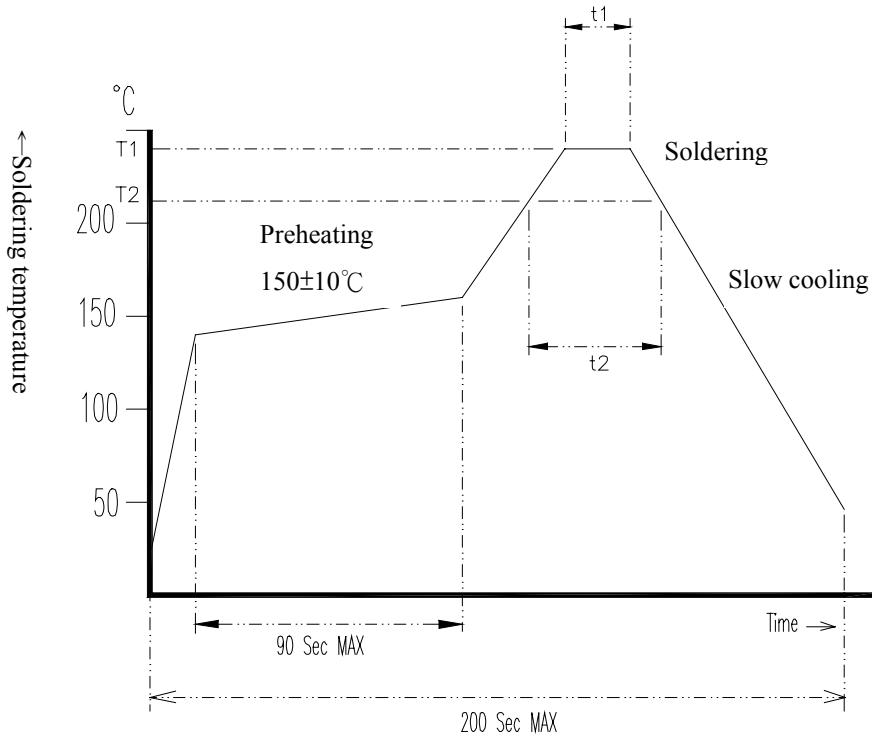

Application	Temperature	Time	T1 / t1	T2 / t2
Lead Free	260±5°C	10 Sec Max	225Min / 60 Sec Max	225Min / 60 Sec Max
Non Lead Free	240±5°C	10 Sec Max	200Min / 40 Sec Max	200Min / 40 Sec Max

■ PACKING

1. CARRIER TYPE

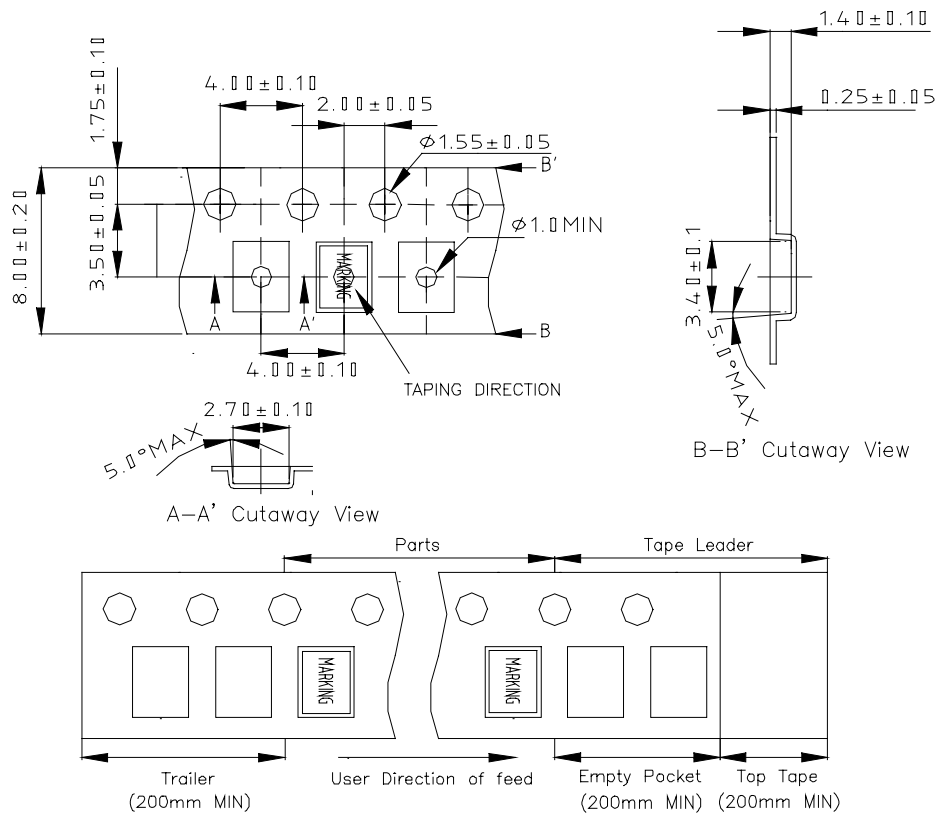

2. REEL : 3000 PCS

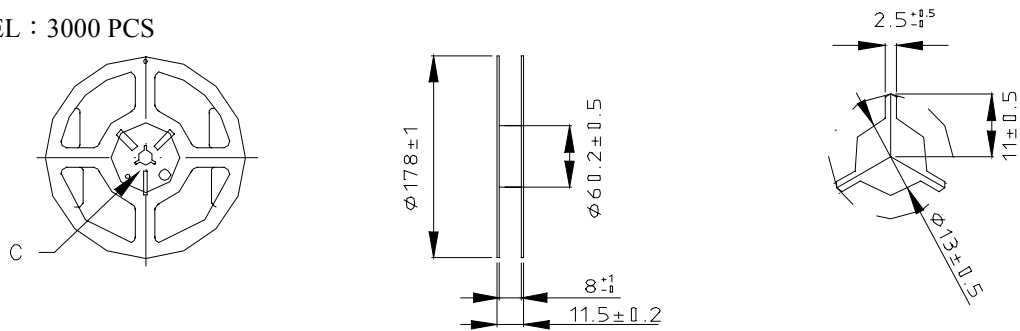

3. LABEL

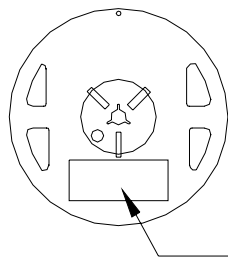

CUSTOMER :	
P.O.# :	
CUST.P/N :	
MFG.P/N :	
FREQ. :	MHZ
	MHZ
TYPE :	D.C. :
Q'TY. :	SPEC. :
LOT NO :	
REMARK 1 :	
REMARK 2 :	