

REV. BB

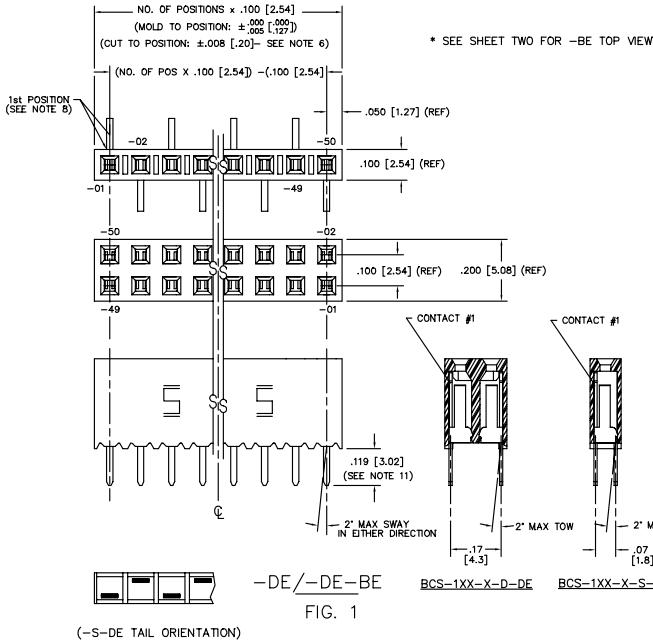

TABLE 1

ENTRY SPEC	BODY SPEC	CONTACT #1	CONTACT #2
-S-DE (SEE FIG.1)	SSM-XX-S	C-95-01-X	-----
-D-DE (SEE FIG.1)	SSM-XX-D	C-95-01-X	-----
-S-TE (SEE FIG.3)	SSM-XX-S	C-95-09-X	-----
-D-TE (SEE FIG.3)	SSM-XX-D	C-95-09-X	-----
-S-HE (SEE FIG.2)	BCH-XX-S	C-58-05-X	-----
-D-HE (SEE FIG.2)	BCH-XX-D	C-58-04-X	C-58-03-X
-S-PE (SEE FIG.4)	SSM-XX-S	C-166-10-X	-----
-D-PE (SEE FIG.4)	SSM-XX-D	C-166-10-X	-----
-S-DE-BE (SEE FIG.1)	SSM-XX-S-BE	C-95-01-X	-----
-D-DE-BE (SEE FIG.1)	SSM-XX-D	C-95-01-X	-----
-S-PE-BE (SEE FIG.4)	SSM-XX-S-BE	C-166-10-X	-----
-D-PE-BE (SEE FIG.4)	SSM-XX-D	C-166-10-X	-----

DIMENSIONS ARE IN INCHES UNLESS OTHERWISE NOTED TOLERANCES ARE ANGLES ±2°

ONE PLACE DECIMALS: ±.1 [2.5] THREE PLACE DECIMALS: ±.005 [.127]
TWO PLACE DECIMALS: ±.01 [.25] FOUR PLACE DECIMALS: ±.0020 [.0508]

TITLE: BOX CONNECTOR SOCKET STRIP

DWG NO: BCS-1XX-XX-X-XX-XX

SHEET 1 OF 2

BCS-1XX-XX-X-XX-XX

NO. OF POSITIONS -02 THRU -50

POLARIZING OPTION
INSERT PK-06-N INTO SPECIFIED POS AND BREAK OFF TAB (NOT AVAILABLE FOR -BE OPTION)

ENTRY SPECIFICATION
-DE: DUAL ENTRY (SEE TABLE 1)
-TE: TOP ENTRY (SEE TABLE 1)
-HE: HORIZONTAL ENTRY (SEE TABLE 1)
-PE: PASS-THROUGH ENTRY (SEE TABLE 1)
-DE-BE: (SEE TABLE 1)
-PE-BE: (SEE TABLE 1)

BODY SPECIFICATION
-S: SINGLE ROW (SEE TABLE 1)
-D: DOUBLE ROW (SEE TABLE 1)

PLATING SPEC.
-T: TIN
-L: LIGHT SELECTIVE
-F: FLASH GOLD
-P: GOLD FLASHED PALLADIUM NICKEL
-S: SELECTIVE
-H: HEAVY GOLD FLASH ON TAIL
-SM: HEAVY GOLD SELECTIVE, MATTE TIN TAIL (SEE TABLE 1)
-TM: MATTE TIN (SEE TABLE 1)
-LM: LIGHT GOLD SELECTIVE, MATTE TIN TAIL (SEE TABLE 1)
-FM: FLASH GOLD SELECTIVE, MATTE TIN TAIL (SEE TABLE 1)

ALL DIMS. DIFFERENT AS SHOWN, OTHERWISE SAME AS FIGURE 1

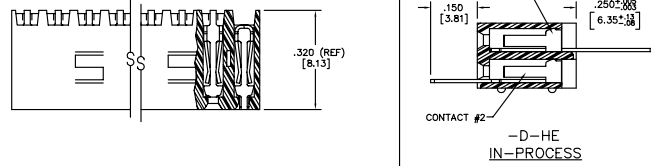
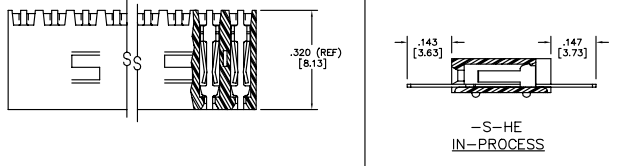
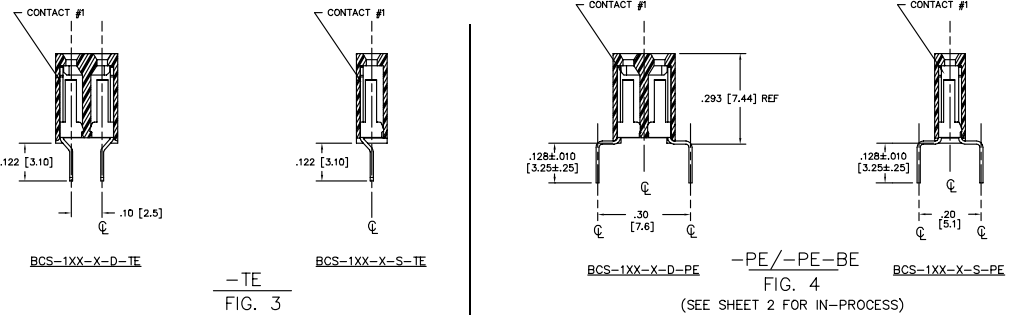

- NOTES:
- PUSHOUT FORCE TO BE: 1 LB. MIN.
 - ⊕ REPRESENTS CRITICAL DIM. FOR STATISTICAL PROCESS CONTROL.
 - CONTACT MATERIAL: PHOSPHOR BRONZE.
 - INSULATOR MATERIAL: BLACK, GLASS-FILLED LCP.
 - [] DIMENSIONS ARE IN MILLIMETERS.
 - MINIMUM WALL THICKNESS ON CUT PARTS: .009.
 - CUT PARTS TO BE SYMMETRICAL ABOUT C. L.
 - 1st POSITION WILL ALWAYS POINT UP ON TOP VIEW AS SHOWN.
 - 1 THROUGH 4 POSITIONS ARE TO BE LAYERED PACKAGED, 5 THROUGH 50 POSITIONS ARE TO BE TUBED FOR THIS PART NUMBER.
 - DAMAGE TO THE CUT SURFACE CAN NOT EFFECT LEAD-IN OF THE CORES.
 - MAX PIN VARIATION WITHIN EACH ROW AND FROM ADJACENT TAIL TO TAIL TO BE .0060

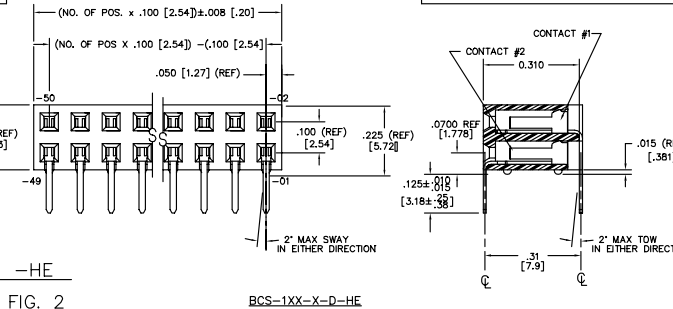
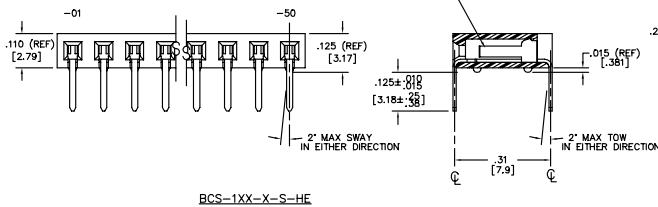

PROPRIETARY NOTE
THIS DOCUMENT CONTAINS APPROVED
SAMTEC'S AND PROPRIETARY
DESIGN INFORMATION. IT IS NOT TO BE
REPRODUCED OR TRANSMITTED IN
ANY FORM OR BY ANY MEANS, ELECTRONIC
OR MECHANICAL, INCLUDING PHOTOCOPYING,
RECORDING, OR BY ANY INFORMATION
SYSTEMS WITHOUT PERMISSION IN WRITING
OBTAINED FROM SAMTEC INC.

EXISPROD/ASSEMBLY/100 BCS-ASM

samtec

520 PARK EAST BLVD. NEW ALBANY, INDIANA 47150
PHONE (812) 944-6733 F.O. BOX 1147
CODE 55322

MADE BY: KOLB 9-12-91

BCS-1XX-XX-X-XX-XX

SHEET 1 OF 2