

FEATURES

- Includes Speech and Ringer Circuit in a single chip
- Operating Range From 15 to 100mA
- DTMF interface with adjustable gain
- Mute input for pulse of DTMF dialing
- Voltage regulator output
- Ring Frequency Discrimination
- Ring Melody Generator

ICM7111 is a low cost CMOS Speech and Ringer integrated circuit (IC) that perform all the necessary speech and line interface functions for telephone sets.

OVERVIEW

TYPICAL APPLICATION CIRCUIT

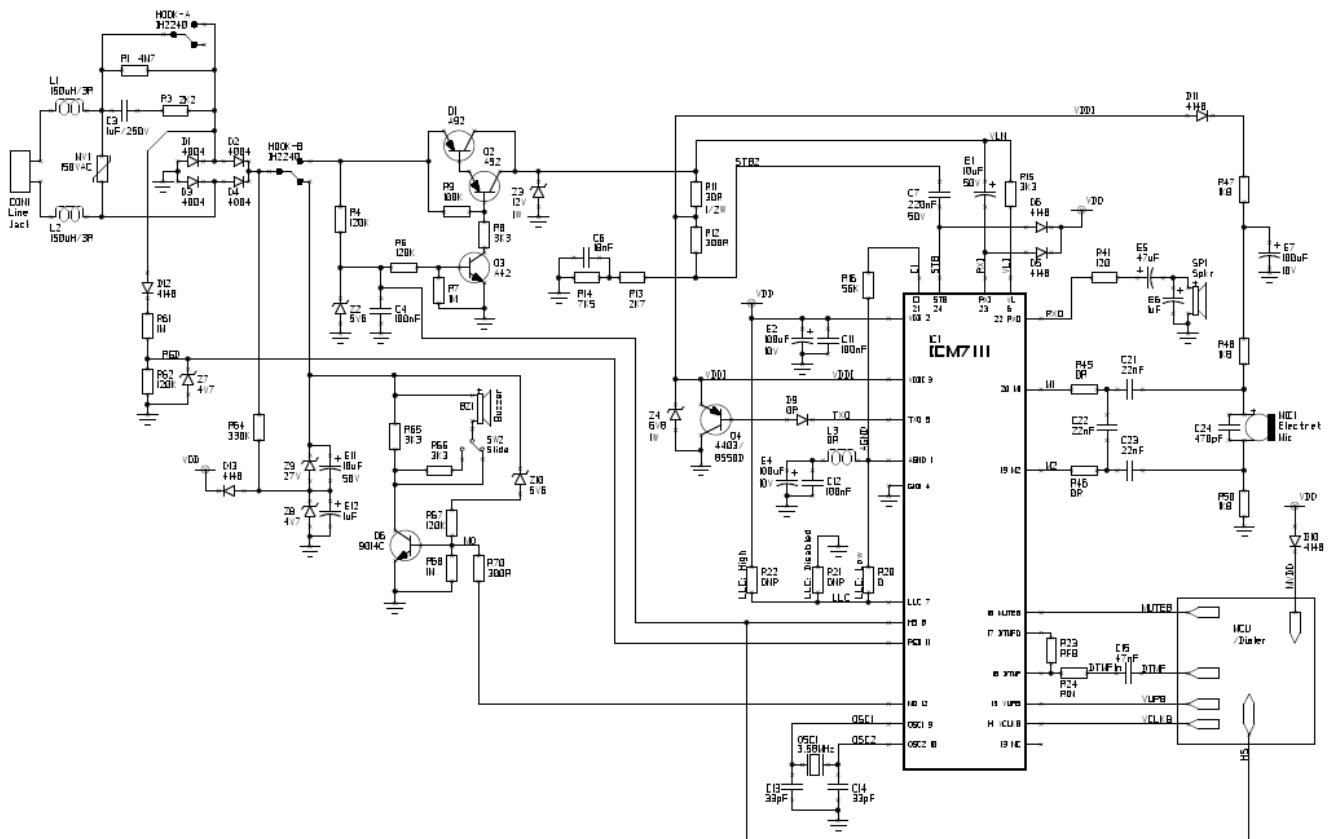
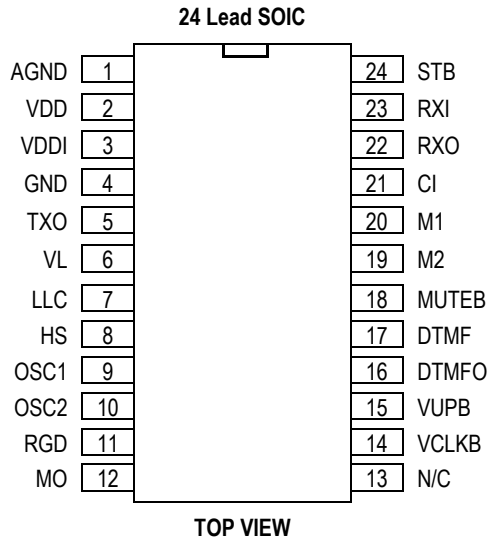

Figure 1: Typical Application Circuit

PACKAGE
24-Lead SOIC



PIN DESCRIPTION

Pin No	Symbol	Description
1	AGND	Analog Ground Analog ground reference.
2	VDD	Regulated Supply Voltage Can be used to power up external microcontroller.
3	VDDI	Supply Input Voltage Power for the chip is extracted from this pin.
4	GND	Ground
5	TXO	Transmit Output Transmit output to be connected to external power transistor for regulating VDDI (dc) and for the modulation of line voltage.
6	VL	Line Voltage
7	LLC	Line Loss Compensation 0V = No LLC; AGND=Low LLC; VDD=High LLC.
8	HS	Hook Switch Input Must be HIGH to activate the speech network. Must be LOW when line is disconnected to properly reset the speech network.
9	OSC1	Oscillator Input 3.58MHz ceramic resonator input.
10	OSC2	Oscillator Output
11	RGD	Ring Detection Input Input for ring frequency detection.
12	MO	Melody Output Melody pulse output for tone ringer. Open drain NMOS.
13	N/C	No Connection
14	VCLKB	Volume Control Clock Input If VUPB = 0; VCLKB pulse increases the volume in 3 steps to maximum. If VUPB = 1; VCLKB pulse decreases the volume in 4 steps to minimum. Has weak internal pull-up. Should be connected to VDD if not used.
15	VUPB	Volume Up/Down Determines whether a pulse on VCLKB would increase or decrease the volume. Has weak internal pull-up. Should be connected to VDD if not used.
16	DTMF	DTMF Input DTMF input (or any analog input signal). Use a series resistor (for input resistance) and a series capacitor (for decoupling) to the DTMF pin. See DTMFO pin.
17	DTMFO	DTMF Feedback Output DTMF feedback output. Connecting a resistor between DTMF and DTMFO pins provides feedback. Referring to Figure 1, $DTMFO = (R23/R24) \times DTMFin$.
18	MUTE B	Mute Transmitter When MUTE B is LOW, the M1/M2 mic input is blocked, and the input from DTMF pin is transmitted. Meant for DTMF dialing.
19 20	M2 M1	Microphone Inputs Input for electret microphone.
21	CI	Complex Impedance Input Connecting capacitor to this pin results in complex AC impedance.
22	RXO	Receive Output These outputs drive a dynamic earpiece.
23	RXI	Receive Input Input for received signal.
24	STB	Side Tone Balance Input Side tone cancellation input.

FUNCTIONAL DESCRIPTION

SYSTEM STARTUP

ICM7111 generates internal power-on-reset when VDD reaches around 1.5V. Power-on-reset appropriately initiates the system to a known initial state.

ICM7111 stays in shutdown mode so long as HS pin stays LOW. However, the ringer circuitry is activated in this mode to monitor the incoming ringing signal.

OSCILLATOR

All the timing of ICM7111 is based on a clock frequency of 3.58 MHz. A crystal oscillator or ceramic resonator of this frequency should be connected to oscillator pins of ICM7111. Care has to be taken in selecting this components since in practise minor deviations from the nominal frequency may occur due to the characteristics of the oscillator used.

It is recommended to connect a small value capacitors ($\leq 47\text{pF}$) in parallel with the oscillator to ensure proper start-up and operation at the nominal frequency.

tone RINGER

The tone ringer of ICM7111 consists of ring detection circuit and melody generator circuit.

Ring Detection Circuit

Ring detection circuit will assures the signal that present on RGD pin input is valid. The signal is considered as a valid signal if the signal has frequencies between 13Hz and 70Hz.

Melody Generator

Once the valid ring signal is detected on the ring detection (RGD) pin and is present for about 75 ms continuously, the melody generator will be activated, the ring signal will be monitored continuously and the melody generator will be immediately turn on or off according to the momentary presence of a valid or unvalid ring signal respectively until next power on reset or off-hook. The melody generator of ICM7111 creates 2 frequencies of 1250Hz and 1600Hz.

SPEECH NETWORK

The speech network of ICM7111 consists of a transmitter and a receiver path, side tone cancellation and line loss compensation.

The speech network is activated as soon as the phone goes off-hook (i.e. when HS pin goes HIGH).

Transmit

For 600 ohm termination, the typical transmit gain from microphone input to the line voltage is 35dB.

Receive

Typical receive path gain is 3dB for 600 ohm termination.

Side Tone Cancellation

As shown in the typical application circuit, side tone cancellation can be achieved best by balancing the Whitestone bridge of R11, R12, and R13 + R14//C6 (refer to Figure 1).

Line Loss Compensation

LLC input level is scanned as the phone goes off-hook (i.e. as HS pin goes HIGH). At the same time, the loop current level is sensed and determined. If LLC=0, no compensation scheme is in effect.

If LLC=AGND, "low" compensation scheme is in effect. Transmit and receive gains are reduced by as much as 6dB when the loop current exceeds 50mA.

If LLC=VDD, "high" compensation scheme is in effect. Transmit and receive gains are reduced by as much as 6dB when the loop current exceeds 75mA.

DTMF/Analog Signal Transmission

ICM7111 can transmit DTMF (or any analog signal) through DTMF pin. Referring to Figure 1, the typical transmit gain is as follow:

$$\text{DTMFO} = (\text{R23/R24}) \times \text{DTMFin}$$

$$\text{TXO} = 4 \times \text{DTMFO}$$

MUTEB must be LOW for the input thru DTMF pin to be transmitted to TXO.

ABSOLUTE MAXIMUM RATING

Symbol	Parameter	Value	Unit
VDDI	Supply Line Voltage	-0.3 to 7.0	V
V _{IN}	Digital Input Voltage	-0.3 to 7.0	V
T _{STG}	Storage Temperature	-55 to +150	°C
T _{SOL}	Soldering Temperature	300	°C

Note 1: Stress greater than those listed under ABSOLUTE MAXIMUM RATINGS may cause permanent damage to the device. This is a stress rating only and functional operation of the device at these or any other conditions above those indicated in the operational sections of this specification is not implied. Exposure to absolute maximum rating conditions for extended periods may affect reliability.

OPERATING RANGE

Range	Ambient Temperature
Commercial	-25 °C to 70 °C

ELECTRICAL CHARACTERISTICS

(I_{LINE} = 15mA unless otherwise specified)

Symbol	Parameter	Test Conditions	Min	Typ	Max	Unit
VDDI	Regulated Line Voltage (DC)	I _{LINE} : 13mA to 100mA		4.0		V
VDD	Regulated Supply	I _{LINE} : 13mA to 100mA		3.7		V
AGND	Regulated AGND reference	I _{LINE} : 13mA to 100mA		1.5		V
I _{DD}	Operating Current	Speech mode Ring mode V _{DD} = 2.5V		3 0.3		mA mA
I _{OL}	Output Current Sink TXO, MO	V _{OL} = 0.4V		1.5		mA
V _{IL}	Input Voltage Low	HS, RGD T _A =25°C	VSS		0.3	VDD
V _{IH}	Input Voltage High	RGD T _A =25°C	0.7		1	VDD
		HS T _A =25°C	2.7		VDD	V
Transmit (TX)						
G _{TX M1M2}	Transmit Gain (M1/M2)	MUTE _B = HIGH		35		dB
G _{TX_DTMF}	Transmit Gain (DTMFO to TXO)	MUTE _B = LOW		12		dB
THD	Distortion	V _{IL} < 0.5 V _{RMS}			2	%
Z _{IN M1M2}	Input Impedance (M1/M2)			20		KΩ
G _{MUTE}	Mute Attenuation (M1/M2)	MUTE _B = LOW	60			dB
V _{IN M1M2}	Input Voltage Range (M1/M2)	Differential Single Ended		+/- 1 +/- 0.5		V _{pp} V _{pp}
Receive (RX)						
G _{RX}	Receive Gain (VL to RXO)			3		dB
THD	Distortion	V _{RXI} < 0.5 V _{RMS}			2	%
Z _{IN_RXI}	Input Impedance (RXI)			8		KΩ
Z _{IN_STB}	Input Impedance (STB)			80		KΩ
V _{IN_RXI}	Input Voltage Range			+/- 2		V _{PEAK}

Output Driver (BJT)						
V _{IN MAX}	Input Voltage Range			+/- 2		V _{PEAK}
V _{TX}	Dynamic Range			+/- 2		V _{PEAK}
RL	Return Loss	Z _{RL} = 1000Ω	18			dB
Side Tone (ST)						
G _{ST}	Side Tone Cancellation		26			dB
V _{IN STB}	Input Voltage Range			+/- 2		V _{PEAK}
HS INPUT						
t _{HS-L}	Low to High Debounce	Going off-hook		15		ms
Tone Ringer						
V _{MO}	Melody Output			PDM		
t _{MD}	Melody Delay				10	ms
F1	Frequency 1			1250		Hz
F2	Frequency 2			1600		Hz
t _{DT}	Detection Time	Ring Freq = 20Hz	50		80	ms
f _{MIN}	Min. Detection Frequency		13			Hz
f _{MAX}	Max. Detection Frequency				70	Hz

APPENDIX A: ICM7111 TYPICAL APPLICATION CIRCUIT

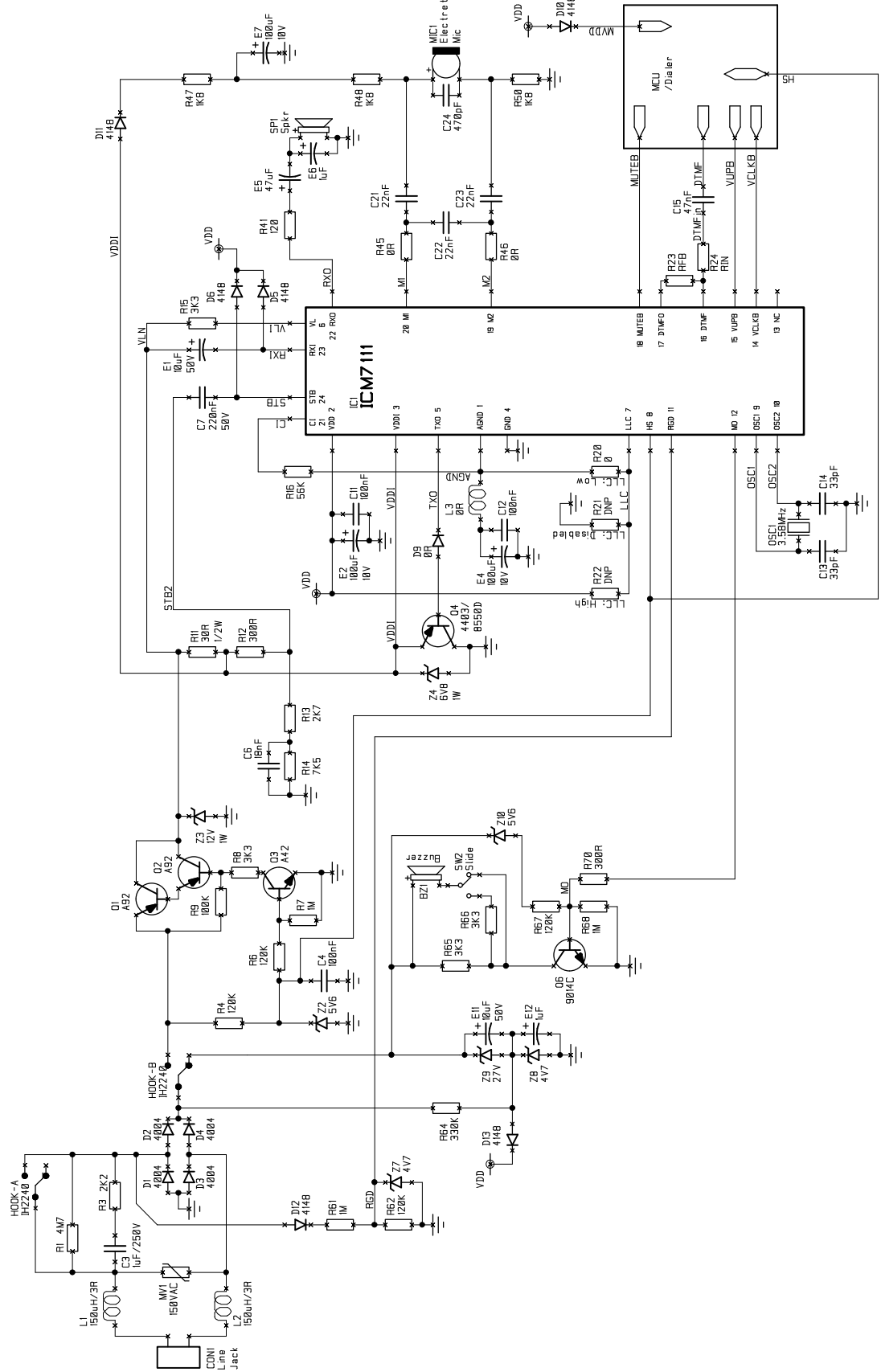

CONTRACT NO.		COMPANY NAME	
APPROVALS		IC MICROSYSTEMS SDN BHD	
DRAWN	DATE	DWG	REV.
CHECKED	10-JUL-06	7111-MB-25A	2.5 A
ISSUED	14-JUL-06	SIZE	DWG NO.
	14-JUL-06	SCALE	SHEET 1 of 1

PACKAGE INFORMATION
24-Lead SOIC (Unit: Inches)

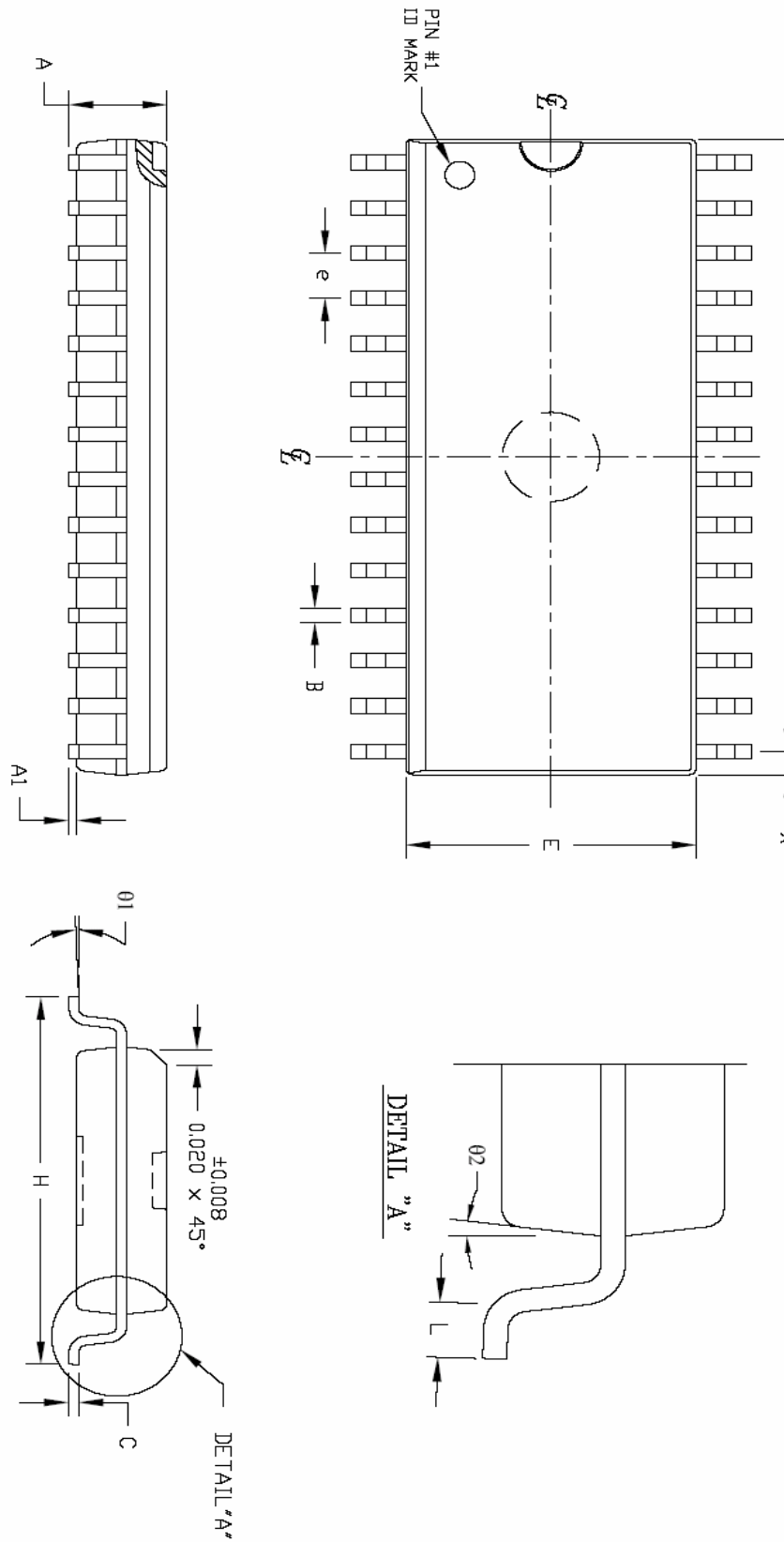

SYMBOL	16 SDIC	
	MIN	MAX
A	0.096	0.104
A1	0.004	0.012
B	0.014	0.020
D	0.398	0.406
E	0.291	0.299
H	0.398	0.414
e	0.050	BSC
C	0.009	0.011
L	0.020	0.040
X	0.026	REF
01	0°	8°
02	7° BSC	

SYMBOL	18 SDIC	
	MIN	MAX
A	0.096	0.104
A1	0.004	0.012
B	0.014	0.020
D	0.452	0.460
E	0.291	0.299
H	0.398	0.414
e	0.050	BSC
C	0.009	0.011
L	0.020	0.040
X	0.028	REF
01	0°	8°
02	7° BSC	

SYMBOL	20 SDIC	
	MIN	MAX
A	0.096	0.104
A1	0.004	0.012
B	0.014	0.020
D	0.498	0.506
E	0.291	0.299
H	0.398	0.414
e	0.050	BSC
C	0.009	0.011
L	0.020	0.040
X	0.026	REF
01	0°	8°
02	7° BSC	

SYMBOL	24 SDIC	
	MIN	MAX
A	0.096	0.104
A1	0.004	0.012
B	0.014	0.020
D	0.598	0.606
E	0.291	0.299
H	0.398	0.414
e	0.050	BSC
C	0.009	0.011
L	0.020	0.040
X	0.026	REF
01	0°	8°
02	7° BSC	

SYMBOL	28 SDIC	
	MIN	MAX
A	0.096	0.104
A1	0.004	0.012
B	0.014	0.020
D	0.698	0.706
E	0.291	0.299
H	0.398	0.414
e	0.050	BSC
C	0.009	0.011
L	0.020	0.040
X	0.026	REF
01	0°	8°
02	7° BSC	

- NOTE:
1. LEAD COPLANARITY SHOULD BE 0 TO 0.10MM (0.004") MAX.
 2. PACKAGE SURFACE FINISHING:
 - (2.1) TOP: MATTE (VDI # 24-27)
 - (2.2) ALL SIDE: MATTE (VDI # 24-27)
 - (2.3) BOTTOM: MATTE (VDI # 24-27)
 3. ALL DIMENSIONS EXCLUDING MOLD FLASHES.

DISCLAIMER

The information contained herein is current as of the date of publication; however, delivery of this document shall not under any circumstances create any implication that the information contained herein is correct as of any time subsequent to such date. ICmic reserves the right to make changes without notification, even if such changes would render information contained herein inaccurate or incomplete. ICmic makes no representation or warranty that any circuit designed by reference to the information contained herein, will function without errors and as intended by the designer.