

Solderless splices

BUTT

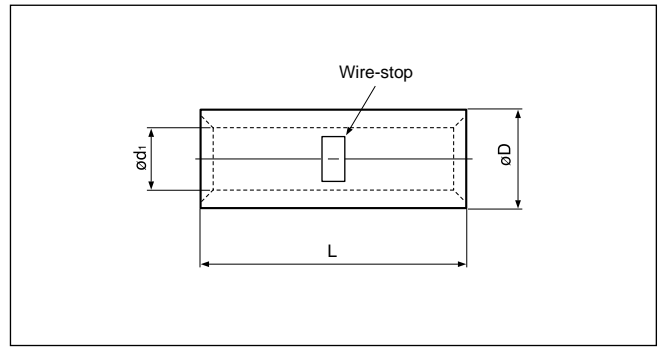

Non-insulated

Certificate No.: E42024 LR20812

Applicable Wire AWG#(mm ²)	Part No.	Standard	Dimensions mm (in.)			Tool No.										Qty/box								
			L	ø D	ø d ₁	YHT-2210	YHT-8S	YA-1	YA-2	YA-4	YA-5	YPT-60N	YPT-150-1	BCT-0514	BCT-860N			BCT-8150	YET-60-1	YET-150-1	YET-300-1	YET-300N		
22 to 16 (0.25 to 1.65)	C-1.25		15.0 (.591)	3.3 (.130)	1.7 (.067)	o	o	o	o				o										1,000	
16 to 14 (1.04 to 2.63)	C-2		15.0 (.591)	4.1 (.161)	2.3 (.091)	o	o	o	o				o											
12 to 10 (2.63 to 6.64)	C-5.5		15.0 (.591)	5.4 (.213)	3.4 (.134)	o	o	o	o				o											
8 (6.64 to 10.52)	C-8		21.0 (.827)	7.0 (.276)	4.5 (.177)		o		o	o	o	o	o	o	o	o	o	o	o	o	o	o	o	500
6 (10.52 to 16.78)	C-14		26.0(1.024)	8.9 (.350)	5.8 (.228)				o	o	o	o	o	o	o	o	o	o	o	o	o	o	o	200
4 (16.78 to 26.66)	C-22		29.0(1.142)	11.3 (.445)	7.7 (.303)						o	o	o		o	o	o	o	o	o	o	o	o	100
2 (26.66 to 42.42)	C-38		32.0(1.260)	13.2 (.520)	9.4 (.370)						o	o	o		o	o	o	o	o	o	o	o	o	50
1/0 (42.42 to 60.57)	C-60		36.0(1.417)	15.3 (.602)	11.4 (.449)						o	o	o		o	o	o	o	o	o	o	o	o	
2/0 (60.57 to 76.28)	C-70		37.0(1.457)	17.5 (.689)	13.3 (.524)							o			o	o	o	o	o	o	o	o	o	
3/0 (76.28 to 96.3)	C-80		38.0(1.496)	19.5 (.768)	14.5 (.571)							o			o	o	o	o	o	o	o	o	o	25
4/0 (96.3 to 117.2)	C-100		38.0(1.496)	22.1 (.870)	16.4 (.646)							o			o	o	o	o	o	o	o	o	o	20
250 to 300MCM (117.2 to 152.05)	C-150		54.0(2.126)	26.4(1.039)	19.5 (.768)							o			o	o	o	o	o	o	o	o	o	
350MCM (152.05 to 192.6)	C-180		57.0(2.244)	28.5(1.122)	21.0 (.827)																		o	
400MCM (192.6 to 242.27)	C-200		63.0(2.480)	32.4(1.276)	24.0 (.945)																		o	10
600 to 650MCM (242.27 to 325)	C-325		72.0(2.835)	37.0(1.457)	28.0(1.102)																		o	

Note: 1) Delivery lead times may vary depending on the product. Contact JST for details.

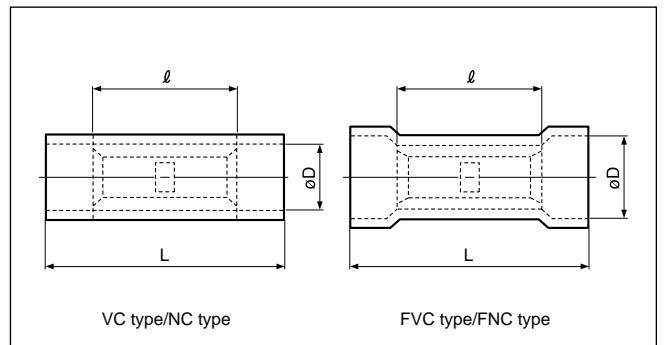
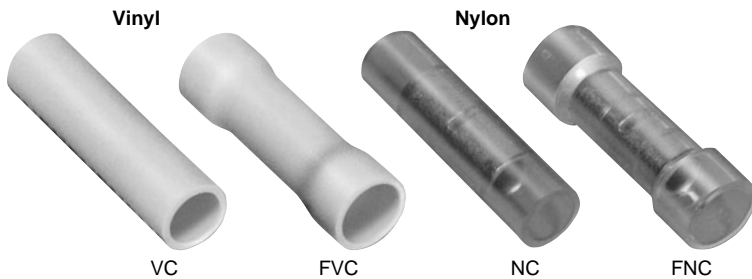

Vinyl or nylon insulated

Certificate No.: E42024 LR20812

Applicable Wire AWG#(mm ²)	Part No.		Standard	Dimensions mm (in.)			Color	Tool No.						Qty/box										
	Vinyl	Nylon		L	l	øD		YNT-2216	YNT-1614	YNT-1210S	YA-1	YA-2	YA-4	BCT-0514	Vinyl	Nylon								
22 to 16 *(0.25 to 1.65)	VC-1.25	NC-1.25		22.7 (.894)	15.0 (.591)	3.2 (.126)	o							o	o	o	o	o	o	o	o	o	1,000	500
	FVC-1.25	FNC-1.25				4.0 (.157)																		
16 to 14 (1.04 to 2.63)	VC-2	NC-2		22.7 (.894)	15.0 (.591)	3.9 (.154)		o						o	o	o	o	o	o	o	o	o	1,000	500
	FVC-2	FNC-2				4.5 (.177)																		
12 to 10 (2.63 to 6.64)	VC-5.5	NC-5.5		26.7(1.051)	15.0 (.591)	5.4 (.213)								o	o	o	o	o	o	o	o	o	500	500
	FVC-5.5	FNC-5.5				6.8 (.268)																		

Note: 1) *The crimping will be more secure if the total cross-sectional area of the wire is at least 0.5 mm².

Examples: If the cross-sectional area of the wire is 0.3mm², fold the wire in two when crimping the terminal.

If the cross-sectional area of the wire is 0.5mm², crimp the terminal onto the wire as it is.

2) Delivery lead times may vary depending on the product. Contact JST for details.

Solderless splices

BUTT

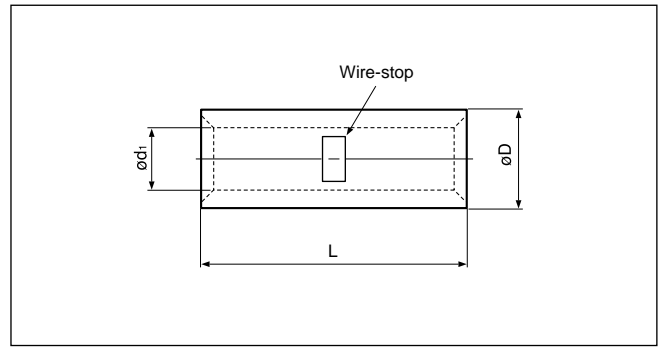
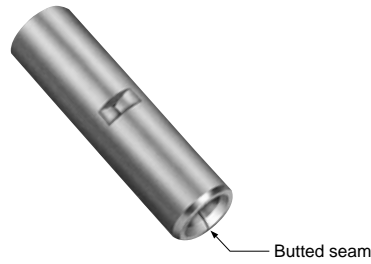

Non-insulated

Certificate No.: E42024 LR20812

Applicable Wire AWG#(mm ²)	Part No.	Standard	Dimensions mm (in.)			Tool No.					Qty/box	
			L	ø D	ø d ₁	YHT-2210	YA-1	YA-2	YA-4	BCT-0514		
22 to 16 (0.25 to 1.65)	WSC-1.25		15.0 (.591)	3.3 (.130)	1.7 (.067)	0	0	0	0	0	1,000	
16 to 14 (1.04 to 2.63)	WSC-2		15.0 (.591)	4.0 (.157)	2.3 (.091)	0	0	0	0	0		
12 to 10 (2.63 to 6.64)	WSC-5.5		15.0 (.591)	5.5 (.217)	3.4 (.134)	0	0	0	0	0		

Note:1) These products have a butted seam.
2) Delivery lead times may vary depending on the product. Contact JST for details.

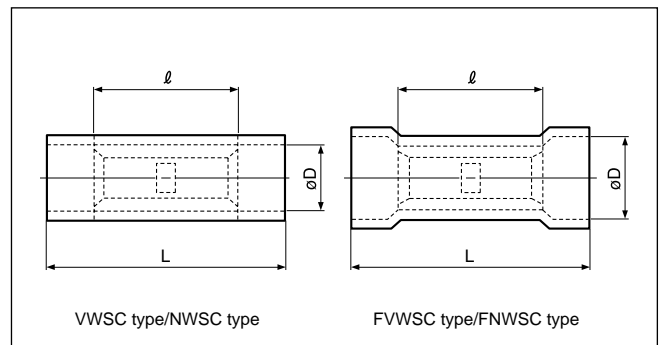
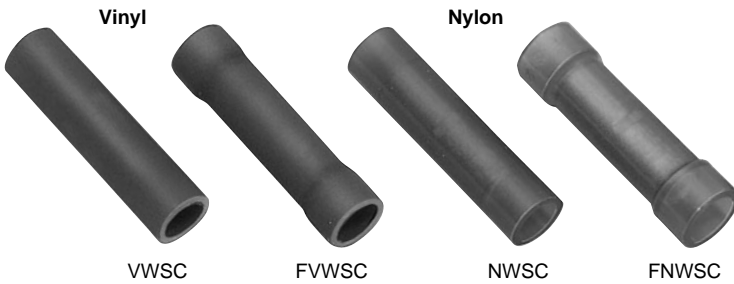

Vinyl or nylon insulated

Certificate No.: E42024 LR20812

Applicable Wire AWG#(mm ²)	Part No.		Standard	Dimensions mm (in.)			Color	Tool No.					Qty/box		
	Vinyl	Nylon		L	ℓ	ø D		YNT-2216	YNT-1614	YNT-1210S	YA-1	YA-2	YA-4	BCT-0514	Vinyl
22 to 16 *(0.25 to 1.65)	VWSC-1.25	NWSC-1.25		22.7 (.894)	15.0 (.591)	3.2 (.126)	0			0	0	0	0	1,000	500
	FWWSC-1.25	FNWSC-1.25				4.0 (.157)									
16 to 14 (1.04 to 2.63)	VWSC-2	NWSC-2		22.7 (.894)	15.0 (.591)	3.9 (.154)	0		0	0	0	0	1,000	500	
	FWWSC-2	FNWSC-2				4.5 (.177)									500
12 to 10 (2.63 to 6.64)	VWSC-5.5	NWSC-5.5		26.7(1.051)	15.0 (.591)	5.4 (.213)	0		0	0	0	0	500	500	
	FWWSC-5.5	FNWSC-5.5				6.8 (.268)									250

Note:1) These products have a butted seam.
2) *The crimping will be more secure if the total cross-sectional area of the wire is at least 0.5 mm².
Examples: If the cross-sectional area of the wire is 0.3mm², fold the wire in two when crimping the terminal.
If the cross-sectional area of the wire is 0.5mm², crimp the terminal onto the wire as it is.
3) Delivery lead times may vary depending on the product. Contact JST for details.