

1:1 Active HDMI™ Redriver with Optimized Equalization & I²C Buffer and RxTerm detection circuitry

Features

- Supply voltage, $V_{DD} = 3.3V \pm 5\%$
- Support for both DVI and HDMI™ signals
- Supports both AC-coupled and DC-coupled inputs
- Supports Deep Color™
- High Performance, up to 2.5 Gbps per channel
- 5V Tolerance on I²C path
- Integrated 50-ohm ($\pm 10\%$) termination resistors at each high speed signal input
- Integrated Rx termination detection circuit
- Configurable output swing control (400mV, 500mV, 600mV, 750mV, 1000mV)
- Configurable Pre-Emphasis levels (0dB, 1.5dB, 3.5dB, & 6.0dB, 9.0dB)
- Configurable De-Emphasis (0dB, -3.5dB, -6.0dB, -9.5dB)
- Optimized Equalization
Single default setting will support all cable lengths
- 8kV Contact ESD protection on all input data/clock channels per IEC61000-4-2
- Hot insertion support on output high speed pins & SCL/SDA pins only
- Propagation delay $\leq 1ns$
- High Impedance Outputs when disabled
- Packaging (Pb-free & Green): 42-contact TQFN (ZH42)

Description

Pericom Semiconductor's PI3HDMI101-B 1:1 active redriver circuit is targeted for high-resolution video networks that are based on DVI/HDMI™ standards and TMDS signal processing. The PI3HDMI101-B is an active redriver with Hi-Z outputs. The device receives differential signals from selected video components and drives the video display unit. This solution also provides a unique advanced pre-emphasis technique to increase rise and fall times which are reduced during transmission across long distances.

Each complete HDMI™/DVI channel also has slower speed, side band signals, that are required to be switched. Pericom's solution provides a complete solution by integrating the side band buffer together with the high speed buffer in a single solution. Using Equalization at the input of each of the high speed channels, Pericom can successfully eliminate deterministic jitter caused by long cables from the source to the sink. The elimination of the deterministic jitter allows the user to use much longer cables (up to 25 meters).

The maximum DVI/HDMI™ Bandwidth of 2.5 Gbps provides 36-bit deep color™ support, which is offered by HDMI™ revision 1.3. The PI3HDMI101-B also provides enhanced robust ESD/EOS protection of 8kV, which is required by many consumer video networks today.

The Optimized Equalization provides the user a single optimal setting that can provide HDMI™ compliance for all cable lengths: 1meter to 20meters and color depths of 8bit/ch, or 12bit/ch.

Pericom also offers the ability to fine tune the equalization settings in situations where cable length is known. For example, if 25meter cable length is required, Pericom's solution can be adjusted to 16dB EQ to accept 25meter cable length.

Using Pericom's patent-pending Rx termination detection circuit, PI3HDMI101-B can automatically disable its own input 50ohm termination when no 50-ohm termination is detected in the HDMI Rx chipset. If a switch is used between the PI3HDMI101-B and the HDMI Rx, our part can detect the 50ohm termination in the switch to determine if our input should be off or on.

Pin Configuration

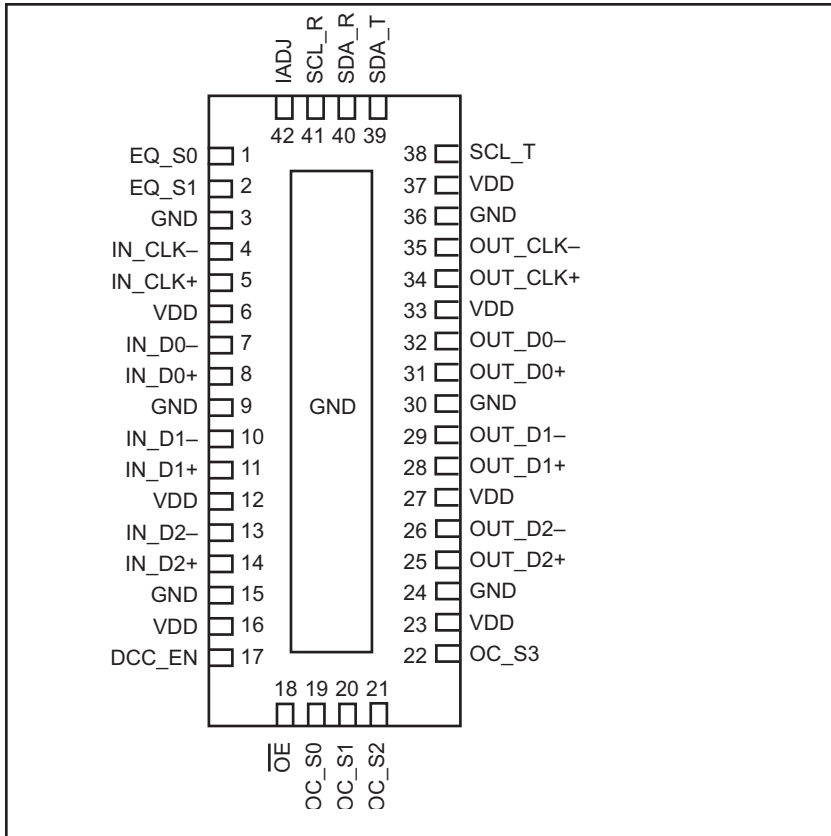

TMDS Receiver Block

Each high speed data and clock input has integrated equalization that can eliminate deterministic jitter caused by input cables. All activity can be configured using pin strapping. The Rx block is designed to receive all relevant signals directly from the HDMI™ connector without any additional circuitry, 3 High speed TMDS data, 1 pixel clock, and DDC signals. TMDS channels have the following termination scheme for Rx Sense support. The switching between 50ohm termination vs. 250Kohm termination is done automatically. The PI3HDMI101-B monitors the 50-ohm termination in the Rx chipset behind our part, and when this 50ohm termination is not present, we disable our 50ohm termination at our input.

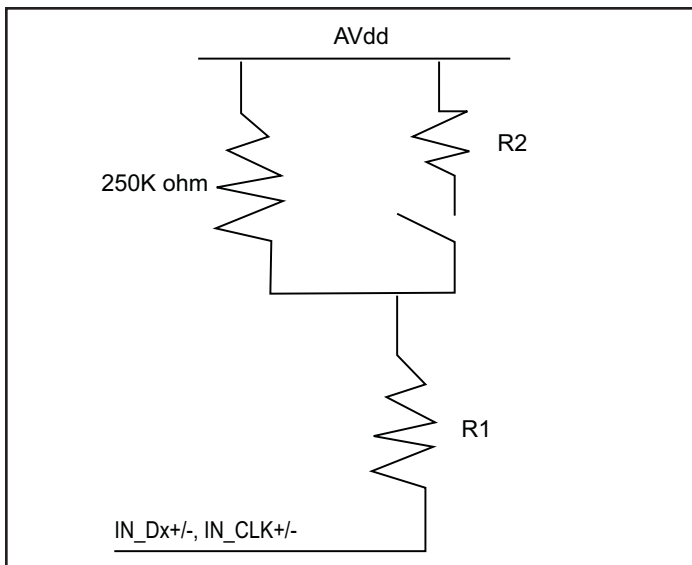

I²C Buffer

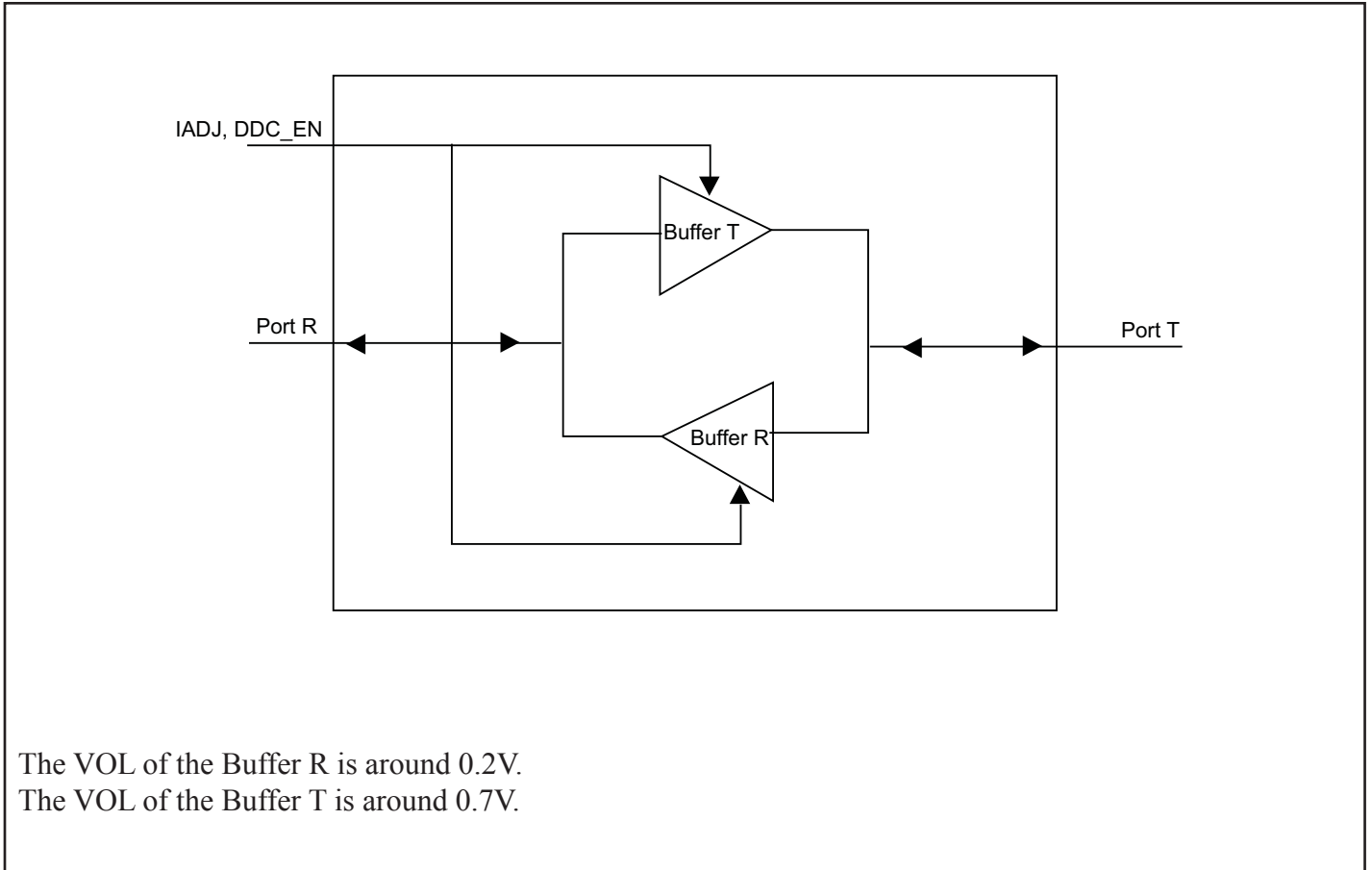

Functional Truth Tables

IADJ	External Pull-Up Range
H	1K Ω to 2K Ω (HDMI spec)
L	> 3K Ω (4.7K Ω typically)

DDC_EN	Port T / Port R (if no external pull-up resistor)
L	Hi-Z (I2C buffer disable)
H	(I2C buffer enable)

Pin Description

Pin #	Pin Name	I/O	Description
5, 8, 11, 14	IN_CLK+, IN_D0+, IN_D1+, IN_D2+	I	TMDS Positive inputs
4, 7, 10, 13	IN_CLK-, IN_D0-, IN_D1-, IN_D2-	I	TMDS Negative inputs
3, 9, 15, 24, 30, 36	GND	P	Ground
18	\overline{OE}	I	Output Enable, Active LOW
41	SCL_R	I/O	DDC Clock , Source Side
40	SDA_R	I/O	DDC Data, Source Side
6, 12, 16, 23, 27, 33, 37	V _{DD}	P	3.3V Power Supply
34, 31, 28, 25	OUT_CLK+, OUT_D0+, OUT_D1+, OUT_D2+	O	TMDS positive outputs
35, 32, 29, 26	OUT_CLK-, OUT_D0-, OUT_ D1-, OUT_D2-	O	TMDS negative outputs
1, 2	EQ_S0, EQ_S1	I	Equalizer controls, both pins with internal pull-ups
19, 20, 21, 22	OC_S0, OC_S1, OC_S2, OC_S3	I	Output buffer controls Note: All 4 pins have internal pull-ups
17	DDC_EN	I	I ² C path enable
38	SCL_T	I/O	DDC Clock, Sink side
39	SDA_T	I/O	DDC Data, Sink side
42	IADJ	I	High/Low Voltage Selection, depends on I ² C external pull-up range

Complete high speed input Rx block is as follows:⁽¹⁾

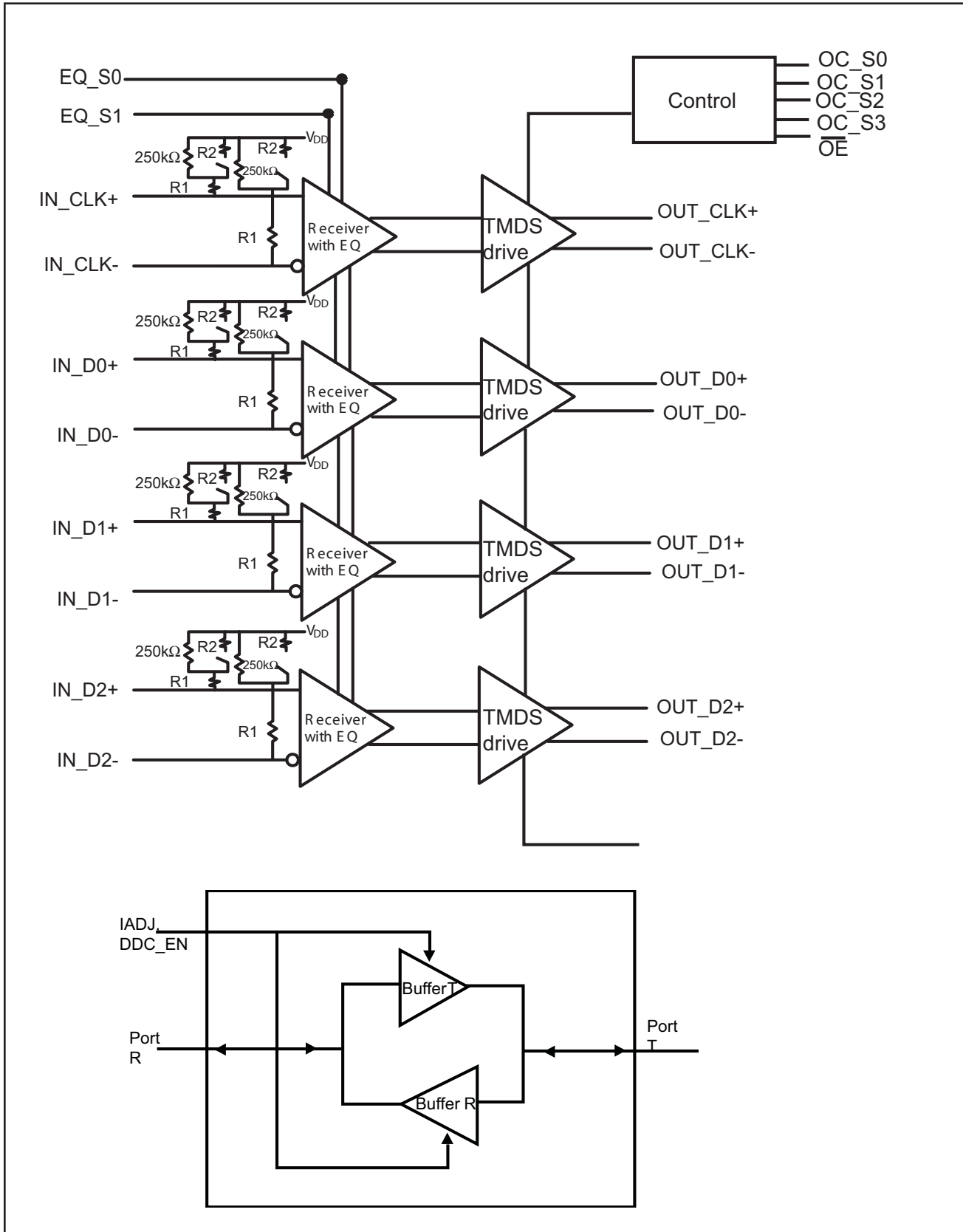

Truth Table

\overline{OE}	Function
0	Active
1	All TMDS outputs are Hi-Z

Truth Table 1

OC_S3 ⁽²⁾	OC_S2 ⁽²⁾	OC_S1 ⁽²⁾	OC_S0 ⁽²⁾	Vswing(mv)	Pre/de-emphasis
1	1	1	1	500	0dB
1	1	1	0	600	0dB
1	1	0	1	750	0dB
1	1	0	0	1000	0dB
1	0	1	1	500	0dB
1	0	1	0	500	1.5dB
1	0	0	1	500	3.5dB
1	0	0	0	500	6dB
0	1	1	1	400	0dB
0	1	1	0	400	3.5dB
0	1	0	1	400	6dB
0	1	0	0	400	9dB
0	0	1	1	1000	0dB
0	0	1	0	666	-3.5dB
0	0	0	1	500	-6dB
0	0	0	0	333	-9dB

EQ Setting Value Logic Table

EQ_S1 ⁽²⁾	EQ_S0 ⁽²⁾	Gain (dB)
1	1	Optimized Equalization (Default Setting)
1	0	8
0	1	3
0	0	15

Notes:

- External pull-ups are required along SCL/SDA path
- Internal 100Kohm pull-ups

Maximum Ratings

(Above which useful life may be impaired. For user guidelines, not tested.)

Storage Temperature	-65°C to +150°C
Supply Voltage to Ground Potential.....	-0.5V to +4.0V
DC Input Voltage	-0.5V to V _{DD}
DC Output Current.....	120mA
Power Dissipation	1.0W

Note:

Stresses greater than those listed under MAXIMUM RATINGS may cause permanent damage to the device. This is a stress rating only and functional operation of the device at these or any other conditions above those indicated in the operational sections of this specification is not implied. Exposure to absolute maximum rating conditions for extended periods may affect reliability.

Recommended Operating Conditions

Symbol	Parameter	Min.	Typ.	Max.	Units
V _{DD}	Supply Voltage	3.135	3.3	3.465	V
T _A	Operating free-air temperature	0		70	°C
TMDS Differential Pins					
V _{ID}	Receiver peak-to-peak differential input voltage	150		1560	mVp-p
V _{IC}	Input common mode voltage	2		V _{DD} + 0.01	V
V _{DD}	TMDS output termination voltage	3.135	3.3	3.465	V
R _T	Termination resistance	45	50	55	ohm
	Signaling rate	0		2.5	Gbps
Control Pins (OC_Sx, EQ_Sx, OE, DDC_EN)					
V _{IH}	LVTTL High-level input voltage	2		V _{DD}	V
V _{IL}	LVTTL Low-level input voltage	GND		0.8	
DDC Pins (SCL_R, SCL_T, SDA_R, SDA_T)					
V _{I(DDC)}	Input voltage	GND		5.5	V
I²C Pins (SCL_T, SDA_T)					
V _{IH}	High-level input voltage	0.7 x V _{DD}		5.5	V
V _{IL}	Low-level input voltage	-0.5		0.3 x V _{DD}	V
V _{ICL}	Low-level input voltage contention ⁽¹⁾	-0.5		0.4	V
I²C Pins (SCL_R, SDA_R)					
V _{IH}	High-level input voltage	0.7 x V _{DD}		5.5	V
V _{IL}	Low-level input voltage	-0.5		0.3 x V _{DD}	V

Notes:

1. V_{IL} specification is for the first low level seen by the SCL/SDA lines. V_{ICL} is for the second and subsequent low levels seen by the SCL_T/SDA_T lines.

TMDS Compliance Test Results

Item	HDMI 1.3 Spec	Pericom Product Spec
Operating Conditions		
Termination Supply Voltage, V_{DD}	$3.3V \leq 5\%$	$3.30 \pm 5\%$
Terminal Resistance	50-ohm $\pm 10\%$	45 to 55-ohm
Source DC Characteristics at TP1		
Single-ended high level output voltage, V_H	$V_{DD} \pm 10mV$	$V_{DD} \pm 10mV$
Single-ended low level output voltage, V_L	$(V_{DD} - 600mV) \leq V_L \leq (V_{DD} - 400mV)$	$(V_{DD} - 600mV) \leq V_L \leq (V_{DD} - 400mV)$
Single-ended output swing voltage, V_{swing}	$400mV \leq V_{swing} \leq 600mV$	$400mV \leq V_{swing} \leq 600mV$
Single-ended standby (off) output voltage, V_{off}	$V_{DD} \pm 10mV$	$V_{DD} \pm 10mV$
Transmitter AC Characteristics at TP1		
Risetime/Falltime (20%-80%)	$75ps \leq \text{Risetime/Falltime} \leq 0.4 \text{ Tbit}$ ($75ps \leq tr/tf \leq 242ps$) @ 1.65 Gbps	240ps
Intra-Pair Skew at Transmitter Connector, max	0.15 Tbit (90.9ps @ 1.65 Gbps)	60ps max
Inter-Pair Skew at Transmitter Connector, max	0.2 Tpixel (1.2ns @ 1.65 Gbps)	100ps max
Clock Jitter, max	0.25 Tbit (151.5ps @ 1.65 Gbps)	82ps max
Sink Operating DC Characteristics at TP2		
Input Differential Voltage Level, V_{diff}	$150 \leq V_{diff} \leq 1200mV$	$150mV \leq V_{DIFF} \leq 1200mV$
Input Common Mode Voltage Level, V_{ICM}	$(V_{DD} - 300mV) \leq V_{icm} \leq (V_{DD} - 37.5mV)$ Or $V_{DD} \pm 10\%$	$(V_{DD} - 300mV) \leq V_{icm} \leq (V_{DD} - 37.5mV)$ Or $V_{DD} \pm 10\%$
Sink DC Characteristics When Source Disabled or Disconnected at TP2		
Differential Voltage Level	$V_{DD} \pm 10mV$	$V_{DD} \pm 10mV$

Electrical Characteristics (over recommended operating conditions unless otherwise noted)

Symbol	Parameter	Test Conditions	Min.	Typ. ⁽¹⁾	Max.	Units
I _{CC}	Supply Current	V _{IH} = V _{DD} , V _{IL} = V _{DD} - 0.4V, R _T = 50-ohm, V _{DD} = 3.3V Data Inputs = 1.65 Gbps HDMI data pattern		120		mA
P _D	Power Dissipation	CLK Inputs = 165 MHz clock OC_Sx = Low, x = 0,1,2,3		400		mW
I _{CCQ}	Standby Current	\overline{OE} = HIGH, V _{DD} = 3.3V, RxSense = LOW		8		mA
TMDS Differential Pins						
V _{OH}	Single-ended high-level output voltage	V _{DD} = 3.3V, R _T = 50-ohm Pre-emphasis/De-emphasis = 0dB	V _{DD} - 10		V _{DD} + 10	mV
V _{OL}	Single-ended low-level output voltage		V _{DD} - 600		V _{DD} - 400	
V _{swing}	Single-ended output swing voltage		400		600	
V _{OD(O)}	Overshoot of output differential volt- age			6%	15%	2x V _{swing}
V _{OD(U)}	Undershoot of output differential volt- age			12%	25%	
ΔV _{OC(SS)}	Change in steady-state common-mode output voltage between logic states			0.5	5	mV
I _(OS)	Short circuit output current			12	mA	
V _{ODE(SS)}	Steady state output differential voltage	OC_Sx = GND, Data Inputs = 250 Mbps HDMI data pattern, 25 MHz pixel clock	560		840	mVp-p
V _{ODE(PP)}	Peak-to-peak output differential voltage		800		1200	
V _{I(open)}	Single-ended input voltage under high impedance input or open input	I _I = 10μA	V _{DD} - 10		V _{DD} + 10	mV
R _{INT}	Input termination resistance	V _{IN} = 2.9V	45	50	55	ohm
Control Pins (\overline{OE}, DDC_EN, IADJ)						
I _{IH}	High-level digital input current	V _{IH} = 2V or V _{DD}	-10		10	μA
I _{IL}	Low-level digital input current	V _I = GND or 0.8 V	-10		10	μA
I²C Pins (SCL_T, SDA_T) (T Port)						
I _{ikg}	Input leakage current	V _I = 5.5 V	-50		50	μA
		V _I = V _{DD}	-10		10	
I _{OH}	High-level output current	V _O = 3.6 V	-10		10	μA
I _{IL}	Low-level input current	V _{IL} = GND	-40		40	μA
V _{OL}	Low-level output voltage	I _{OL} = 2.5 mA IADJ = H	0.65		0.9	V
C _{IO}	Input/output capacitance	V _I = 5.0 V or 0 V, Freq = 100kHz			25	pF
		V _I = 3.0 V or 0 V, Freq = 100kHz			10	
V _{OH(TTL)} ¹	TTL High-level output voltage	I _{OH} = -8 mA	2.4			V
V _{OL(TTL)} ¹	TTL Low-level output voltage	I _{OL} = 8 mA			0.4	V

Note:

1. Voh/Vol of external driver at the R and T ports.

(Table Continued)

I ² C Pins (SCL_R, SDA_R) (R Port)						
I _{ikg}	Input leakage current	V _I = 5.5 V	-50		50	μA
		V _I = V _{DD}	-10		10	
I _{OH}	High-level output current	V _O = 3.6 V	-10		10	μA
I _{IL}	Low-level input current	V _{IL} = GND	-10		10	μA
V _{OL}	Low-level output voltage	I _{OL} = 4 mA, IADJ = H			0.2	V
C _I	Input capacitance	V _I = 5.0 V or 0 V, Freq = 100kHz			25	pF
		V _I = 3.0 V or 0 V, Freq = 100kHz			10	

Switching Characteristics (over recommended operating conditions unless otherwise noted)

Symbol	Parameter	Test Conditions	Min.	Typ. ⁽¹⁾	Max.	Units
TMDS Differential Pins						
tpd	Propagation delay	V _{DD} = 3.3V, R _T = 50-ohm, pre-emphasis/de-emphasis = 0dB			2000	ps
t _r	Differential output signal rise time (20% - 80%)		75		240	
t _f	Differential output signal fall time (20% - 80%)		75		240	
t _{sk(p)}	Pulse skew			10	50	
t _{sk(D)}	Intra-pair differential skew			23	50	
t _{sk(o)}	Inter-pair differential skew ⁽²⁾				100	
t _{jit(pp)}	Peak-to-peak output jitter from TMDS clock channel	pre-emphasis/de-emphasis = 0dB, Data Inputs = 1.65 Gbps HDMI data pattern CLK input = 165 MHz clock		15	30	ps
t _{jit(pp)}	Peak-to-peak output jitter from TMDS data channel			18	50	
t _{DE}	De-emphasis duration	de-emphasis = -3.5dB, Data Inputs = 250 Mbps HDMI data pattern, CLK output = 25 MHz clock		240		
t _{SX}	Select to switch output				10	ns
t _{en}	Enable time				200	
t _{dis}	Disable time				10	

I²C PINS (SCL_R, SDA_R, SCL_T, SDA_T)

t _{PLH}	Propagation delay time, low-to-high-level output SCL_T/SDA_T to SCL_R/SDA_R	IADJ = V _{DD} C _{LOAD} = 300 pF			500	ns
t _{PHL}	Propagation delay time, high-to-low-level output SCL_T/SDA_T to SCL_R/SDA_R	T _{buffer} : R _{pu} = 2K, V _{pu} = 3.0V			136	
t _{PLH}	Propagation delay time, low-to-high-level output SCL_T/SDA_T to SCL_R/SDA_R	R _{buffer} : R _{pu} = 1.2K, V _{pu} = 3.3V or R _{pu} = 1.8K, V _{pu} = 5V			450	
t _{PHL}	Propagation delay time, high-to-low-level output SCL_T/SDA_T to SCL_R/SDA_R	IADJ = GND C _{LOAD} = 100 pF			136	
t _r	SCL_T/SDA_T Output signal rise time	See Fig. A			999	
t _f	SCL_T/SDA_T Output signal fall time				90	
t _r	SCL_R/SDA_R Output signal rise time				999	
t _f	SCL_R/SDA_R Output signal fall time				90	

(Table Continued)

t_{set}	Enable to start condition		6	10	ns
t_{hold}	Enable after stop condition		6	10	

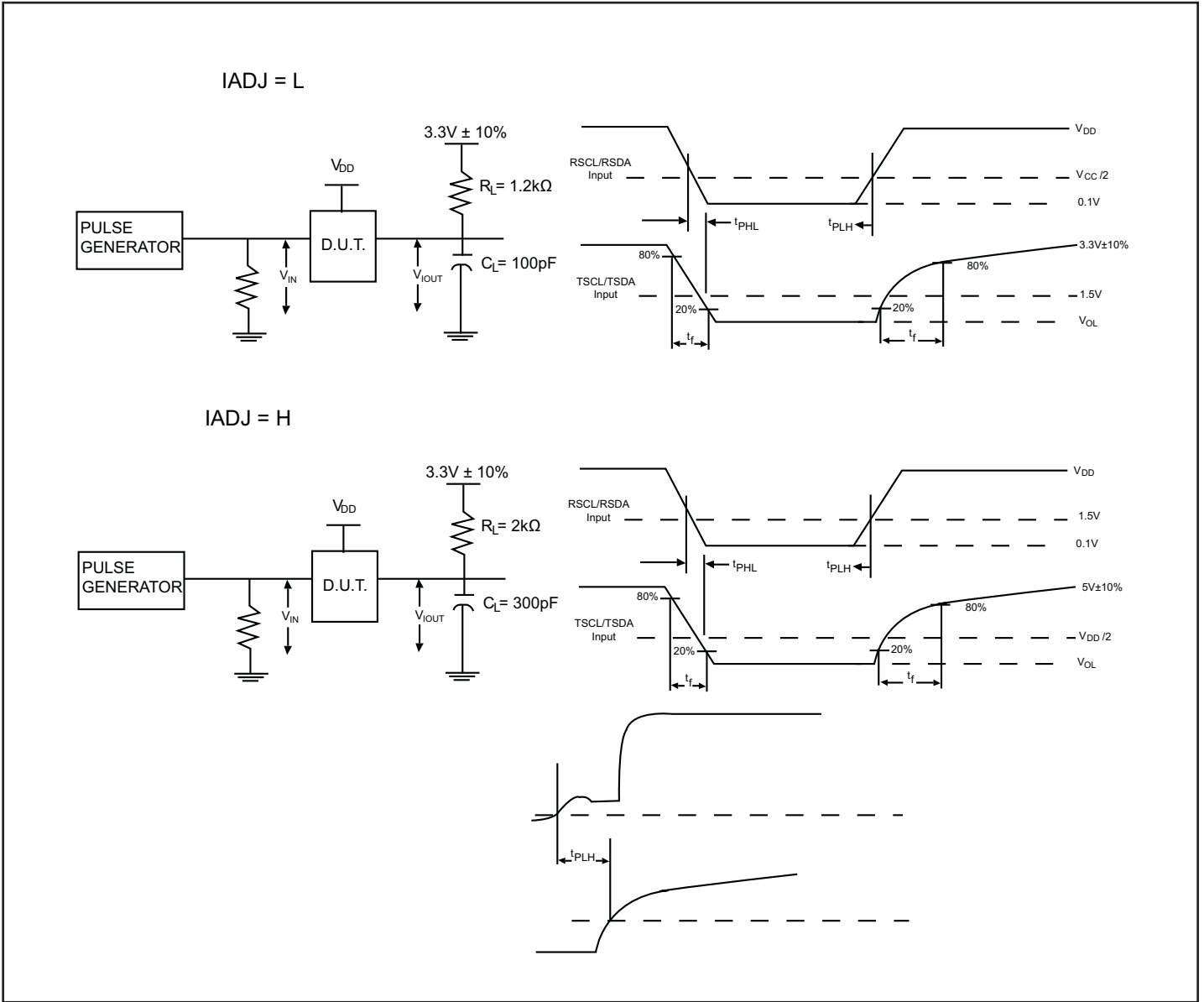

Figure A. I²C Timing Test Circuit and Definition

Application Information

Supply Voltage

All V_{DD} pins are recommended to have a 0.01uF capacitor tied from V_{DD} to GND to filter supply noise

TMDS inputs

Standard TMDS terminations have already been integrated into Pericom's PI3HDMI101-A device. Therefore, external terminations are not required. Any unused port must be left floating and not tied to GND.

Package Mechanical: 42-pin, Low Profile Quad Flat Package (ZH42)

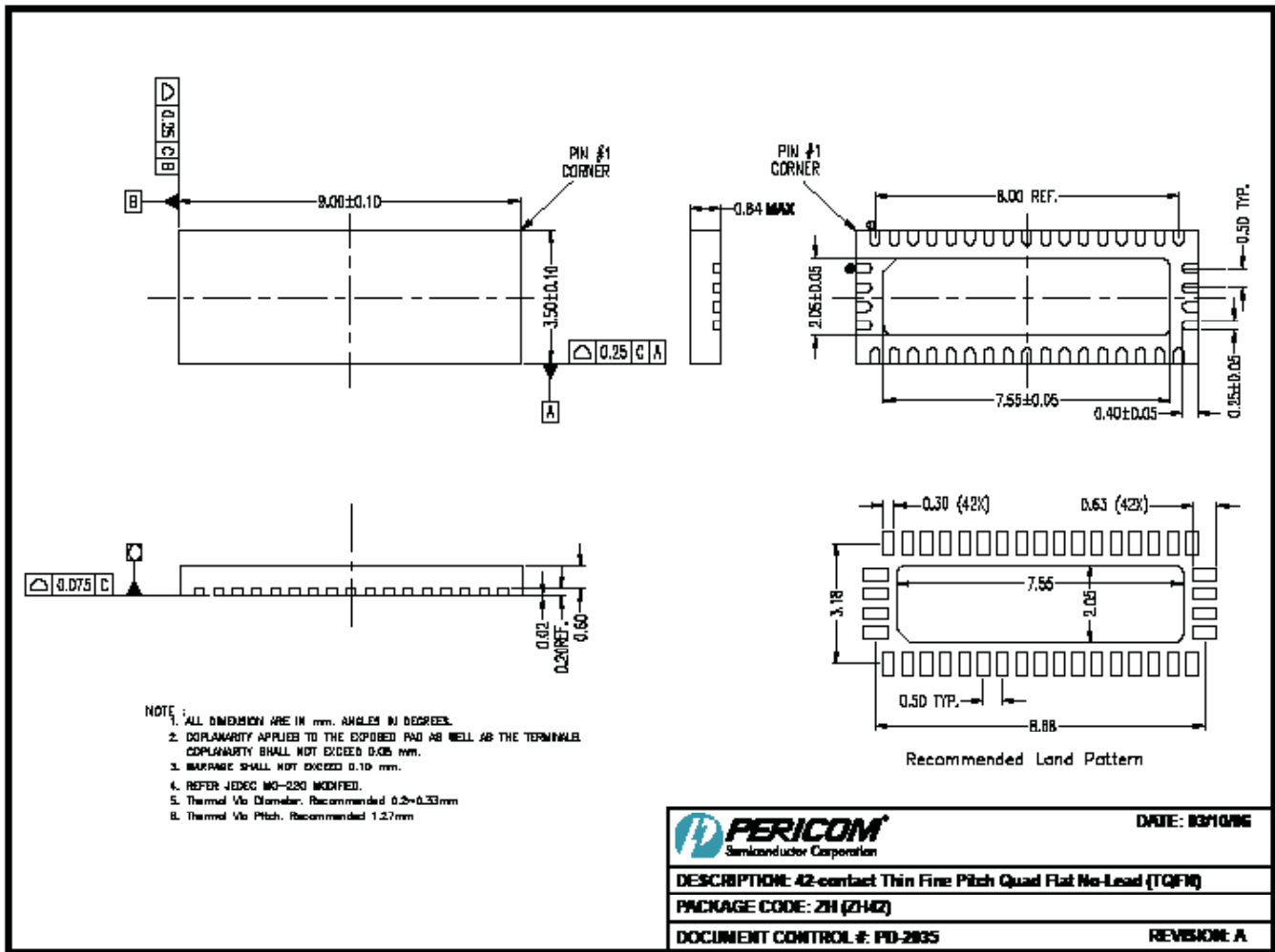

06-0219

Ordering Information

Ordering Code	Package Code	Package Description
PI3HDMI101-BZHE	ZH	42-pin, Pb-free & Green TQFN

Notes:

- Thermal characteristics can be found on the company web site at www.pericom.com/packaging/
- E = Pb-free and Green
- Adding an X Suffix = Tape/Reel
- HDMI & Deep Color are trademarks of Silicon Image



HDMI Licensing, LLC, a wholly owned subsidiary of Silicon Image, Inc., is the agent responsible for licensing the HDMI Specification, promoting the HDMI standard and providing education on the benefits of HDMI to retailers and consumers. The HDMI Specification was developed by Sony, Hitachi, Thomson (RCA), Philips, Matsushita (Panasonic), Toshiba and Silicon Image as the digital interface standard for the consumer electronics market. The HDMI specification combines uncompressed high-definition video and multi-channel audio in a single digital interface to provide crystal-clear digital quality over a single cable. For more information about HDMI, please visit www.hdmi.org