



MIC2587 Evaluation Board

Single Channel, Positive-Voltage Hot Swap Controller

General Description

MIC2587/MIC2587R Hot Swap Controller

The MIC2587 is a single-channel, positive-voltage hot-swap controller designed to address the need for safe insertion and removal of circuit boards into electrically live system backplanes. With few external components, the controller works in conjunction with an external N-Channel MOSFET to provide inrush current limiting and gate slew-rate control. Additionally, the current limit is user-programmable and works in conjunction with a user-programmable overcurrent timer to provide reliable overcurrent fault protection to the system's circuit components. During an output overload condition, a constant-current regulation loop is engaged to ensure that the system power supply maintains regulation. As a means to reduce the power consumption in the presence of a severe overcurrent load, the MIC2587 is equipped with a circuit that monitors the voltage level at the FB pin, and once engaged, allows for the current limit to "foldback" to a lower threshold to effectively reduce the regulated current limit. Once the overcurrent timer expires, the output of the MIC2587 is latched off and can be reset by toggling the ON pin from high-to-low-to-high. The MIC2587R will automatically restart the turn-on cycle with a fixed duty cycle ($\approx 5\%$) after the overcurrent timer has expired. A master Power-Good signal is provided to indicate that the output voltage of the soft-start circuit is within its valid output range. The Power-Good signal can be used to enable one or more downstream DC-DC converter modules.

MIC2587 Evaluation Board

The MIC2587 evaluation board is designed to showcase the power switching capability of the MIC2587 controller. The board is configured for switching 24V or 48V with a nominal current limit of 4.7A. Several test points are included for the user to monitor the response of a number of pins (e.g. VIN, GATE, TIMER, and /PWRGD). The Power-Good signal is an open-drain output, with asserted status as either high impedance (-1) or active-Low (-2). Additionally, banana plugs are provided to

allow for the use of high-current electrical cables to transfer the necessary current through the power MOSFET and to the load. See the **Operation** section for details on how to select the values for these components for desired system requirements. (Please refer to the MIC2587 datasheet for detailed pin descriptions and additional support information.)

Basic Requirements

The MIC2587 controller requires a minimum of 10V for operation, and the evaluation board is configured to operate with 24V or 48V, depending upon the resistor divider networks that are shown in a table inserted in the circuit schematic.

Precautions

Unless the range of voltages over which the intended application for the MIC2587/MIC2587R controller is well controlled and carefully observed, the input and output capacitors should have a maximum voltage rating of at least 100V. Thus, the rating of these capacitors is at minimum equivalent to the 100V transient maximum voltage rating of the MIC2587 integrated circuits.

Note: The input capacitor should be an aluminum electrolytic device, as most tantalum capacitors in this voltage range are not capable of safely handling the surge currents that will flow through C_{IN} during a hot-plug event. C_{OUT} , however, may be a tantalum capacitor as the MIC2587 controls the di/dt and dv/dt seen by C_{OUT} .

Ordering Information

Part Number	Description
MIC2587-1BM EV	Evaluation board with the MIC2587-1BM device
MIC2587R-1BM EV	Evaluation board with the MIC2587R-1BM device

Operation

External Switch

The MIC2587 requires an external N-Channel MOSFET to serve as the power switch device. The MIC2587 pin connections for the MOSFET terminals and sense resistor are shown in the attached circuit schematic. The SUM110N10-09, a power MOSFET in a TO-263 package from Vishay, is used as the pass device on the evaluation boards. Several MOSFET devices suited for use with the MIC2587 are listed in Table 3 at the end of the datasheet.

The ON control pin will switch the external MOSFET on when the voltage at ON is greater than the specified threshold voltage of 1.24V (typical). This pin exhibits 50mV of hysteresis. A three terminal jumper (J1) is used to either pull-up the ON pin to VCC (through an external resistive divider) or tie the pin-to-ground to disable the controller.

Component Selection for Various V_{IN}

Table 1 below displays the resistor values selected to configure the MIC2587 controller with various input voltages. The two resistor combinations are implemented as resistive divider networks to attain specific turn-on/turn-off and "Power-is-Good" thresholds. These values are used for reference, but for different threshold requirements, alternative resistor combinations may be chosen that satisfy Equations 8 and 9 from the MIC2587 datasheet.

	+16V	+24V	+32V	+48V
R1	95.3k Ω	49.9k Ω	261k Ω	287k Ω
R2	10.0k Ω	3.40k Ω	12.4k Ω	10.0k Ω
R5	35.7k Ω	59.0k Ω	93.1k Ω	143k Ω
R8	3.57k Ω	3.57k Ω	4.22k Ω	4.22k Ω
$V_{IN(ON)}$	13.8V	20.6V	29.0V	39.0V
$V_{IN(OFF)}$	13.0V	19.3V	27.0V	36.6V
$V_{OUT(GOOD)}$	14.4V	23.0V	30.3V	45.8V
$V_{OUT(NOT_GOOD)}$	13.5V	21.6V	28.4V	43.0V

Table1. Resistor Combinations for Various System Voltage Levels

Current Limit

The current-limit is determined using the following formula:

$$I_{LIM} = V_{TRIP} / R_{SENSE} \quad (1)$$

where V_{TRIP} is the circuit breaker threshold obtained from the Electrical Characteristics Table in the MIC2587 datasheet. For the MIC2587 evaluation board, the nominal current limit $I_{LIM} = 47mV/10m\Omega = 4.7A$. Using Equation 1 and some basic algebra, the value for R_{SENSE} can be determined given a desired current-limit by:

$$R_{SENSE} = V_{TRIP} / I_{LIM}$$

The circuit breaker is 'tripped' upon an overcurrent condition that lasts longer than the time period t_{FLT} , which is set by capacitor C_{TIMER} (C7). If $C_{TIMER} = 0$, $t_{FLT} = t_{OCSENSE}$, the default value of 2 μ s. C_{TIMER} may be determined for a desired t_{FLT} using the following formula¹.

$$C_{TIMER} = (I_{TIMERUP} * t_{FLT}) / V_{TIMERH} \quad (2)$$

where I_{TIMER} , the typical current-limit timer current, is 65 μ A, and V_{TH} , the typical timer threshold, is 1.313V. Both values are found in the Electrical Characteristics Table of the datasheet. Substituting these values into Equation 2, the result is now approximated by:

$$C_{TIMER} \cong 50 \times 10^{-6} (A/V) * t_{FLT}$$

For a 6ms overcurrent delay, the calculated value for C_{TIMER} is 0.3 μ F. The closest standard value is 0.33 μ F.

Programmable Output Slew Rate (C_{GATE})

Capacitor C_{GATE} is used to set the output slew rate and limit the inrush current. An external GATE capacitor, C_{GATE} , sets the GATE output rise-time (or slew rate) to turn on the external Power MOSFET. The source (output) of the MOSFET then follows the GATE once the GATE voltage exceeds the V_{G-S} threshold. The rise time is determined by the following equation:

$$t_{RISE} \cong (\Delta V * C_{TOTAL}) / I_{GATE} \quad (3)$$

where $\Delta V = V_{IN} + 13V$ (13V typical enhancement for MIC2587 GATE output for $10V \leq V_{CC} \leq 80V$) and I_{GATEON} is the nominal GATE pin pull-up current. The total capacitance that the GATE must drive is the external C_{GATE} plus the parasitic capacitance, C_{G-S} , of the external MOSFET. For the SUM110N10-09, C_{G-S} is approximately 6.5nF. Given the following conditions:

$$V_{IN} = V_{OUT} = 24V \text{ and } C_{GATE} = 47nF$$

$$t_{RISE} \cong (13V * 6.5nF) / 16\mu A \cong 5.3ms$$

R7 is used for stabilization of the current limit control loop.

Circuit Schematic

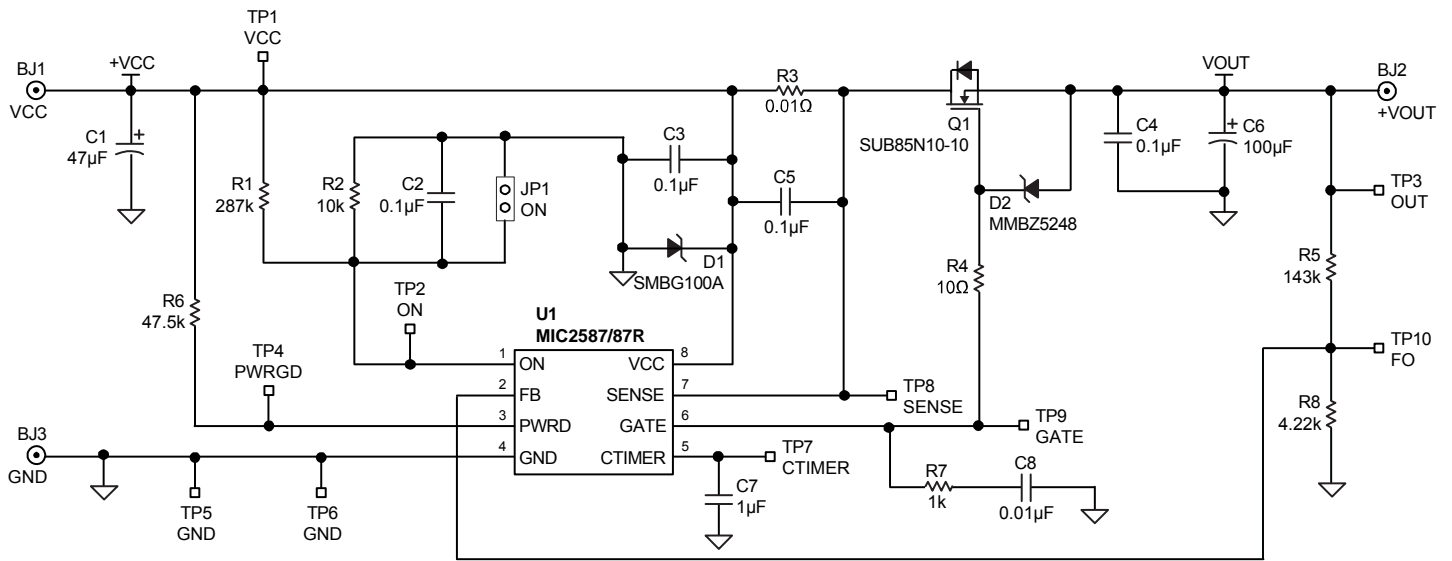

	+48V	+24V
R1	287k	49.9k
R2	10k	3.4k
R5	143k	59k
R8	4.22k	3.57k

Figure 1. MIC2587 EVB Circuit Schematic

Bill of Materials

Item	Part Number	Manufacturer	Description	Qty.
BJ1-BJ3	108-0740-001	Johnson ⁽¹⁾	Banana Jack, 0.256" H/S	3
C1	2222 038 59479	Vishay ⁽²⁾	Electrolytic Capacitor, 47 μ F, 100V, 20%, Size 10x12	1
C2-C4	VJ0805V104MXBCW1BC	Vishay ⁽²⁾	Ceramic Capacitor, 0.1 μ F, 100V, 20%, Y5V, Size 0805	3
C5	VJ0805A331FXBAB	Vishay ⁽²⁾	Ceramic Capacitor, 330pF, 100V, 1%, COG, Size 0805	1
C6	2222 0385 9101	Vishay ⁽²⁾	Electrolytic Capacitor, 100 μ F, 100V, 20%, Size 10X12	1
C7	CF162E0105J	AVX ⁽³⁾	Ceramic Capacitor, 1 μ F, 100V, 20%, PET-HT, Size 4030	1
C8	VJ0805V103MXBCW1BC	Vishay ⁽²⁾	Ceramic Capacitor, 0.01 μ F, 100v, 20%, Y5V, Size 0805	1
D1	SMBG100A/2	Vishay ⁽²⁾	Transzorb Diode, 100V	1
D2	MMBZ5248B-GS08	Vishay ⁽²⁾	Zener Diode, 18V,5%	1
J1	22-03-2021	Molex ⁽⁴⁾	Jumper, 2-pin, 0.1" Center, 0.35" Hole	1
	881545-2	Tyco ⁽⁵⁾	Jumper Shunt	1
MH1-MH4	534-2211	Keystone ⁽⁶⁾	Stand-off - 5/8", 6-32,Hex	4
MH1-MH4	5721-632-3/8	Keystone ⁽⁶⁾	Machine Screws, 6-32 x 3/8	4
R1	CRCW080549K9FKTA	Vishay ⁽²⁾	Resistor, 49.9K, 1%, Size 0805	1
R2	CRCW08053K40FKTA	Vishay ⁽²⁾	Resistor, 3.4K, 1%, Size 0805	1
R3	WSR2R0100FTA	Vishay ⁽²⁾	Resistor, 0.01 Ω , 1%, 2w, Size 4527	1
R4	CRCW080510R0FKTA	Vishay ⁽²⁾	Resistor, 10 Ω , 1%, Size 0805	1
R5	CRCW080559K0FKTA	Vishay ⁽²⁾	Resistor, 59k, 1%, Size 0805	1
R6	CRCW080547K5FKTA	Vishay ⁽²⁾	Resistor, 47.5k, 1%, Size 0805	1
R7	CRCW08051K002FKTA	Vishay ⁽²⁾	Resistor, 1k, 1%, Size 0805	1
R8	CRCW08053K57FKTA	Vishay ⁽²⁾	Resistor, 3.57k, 1%, Size 0805	1
Q1	SUM110N10-09	Vishay ⁽²⁾	N-Channel, 100V, MOSFET	1
TP1-TP10	1593-2	Keystone ⁽⁶⁾	Turret Terminal, 0.065" H/S	10
U1	MIC2587-1BM or MIC2587R-1BM	Micrel⁽⁷⁾	Single Channel, Positive-Voltage Hot Swap Controller	1

Notes:

1. Johnson: www.tdk.com
2. Vishay: www.vishay.com
3. AVX: www.avx.com
4. Molex: www.molex.com
5. Tyco: www.tycoelectronics.com
6. Keystone: www.keyeleco.com
7. **Micrel, Inc.:** www.micrel.com

PCB Layout Recommendation

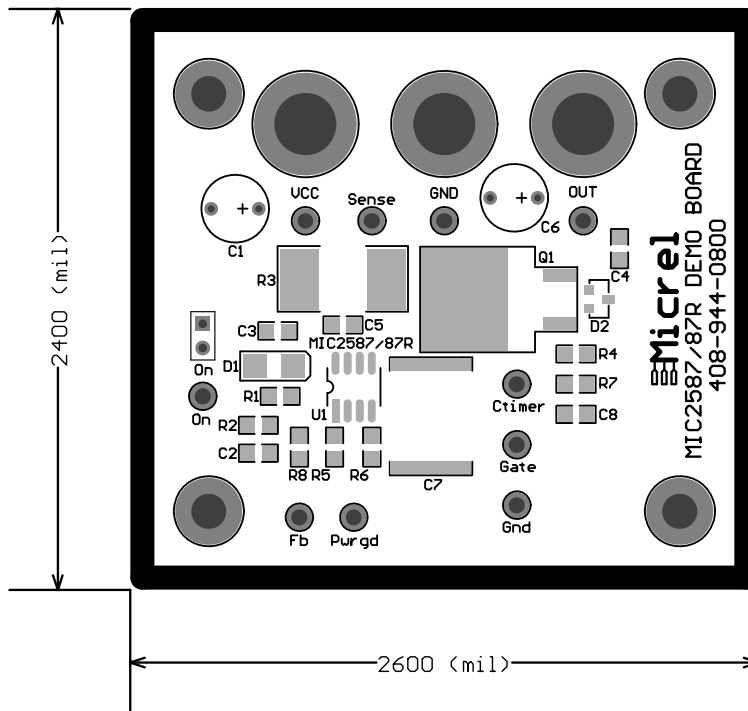

Top Assembly

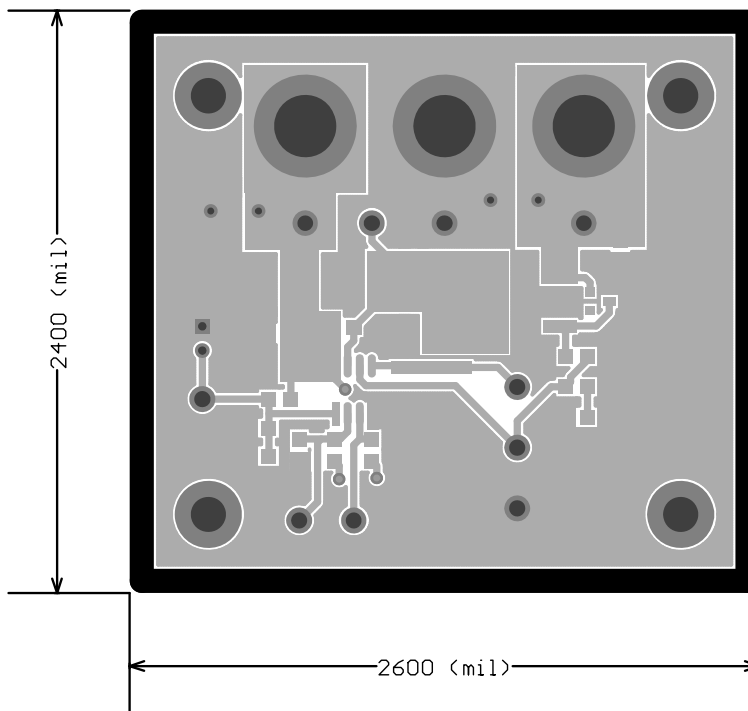

Top Layer

PCB Layout Recommendation

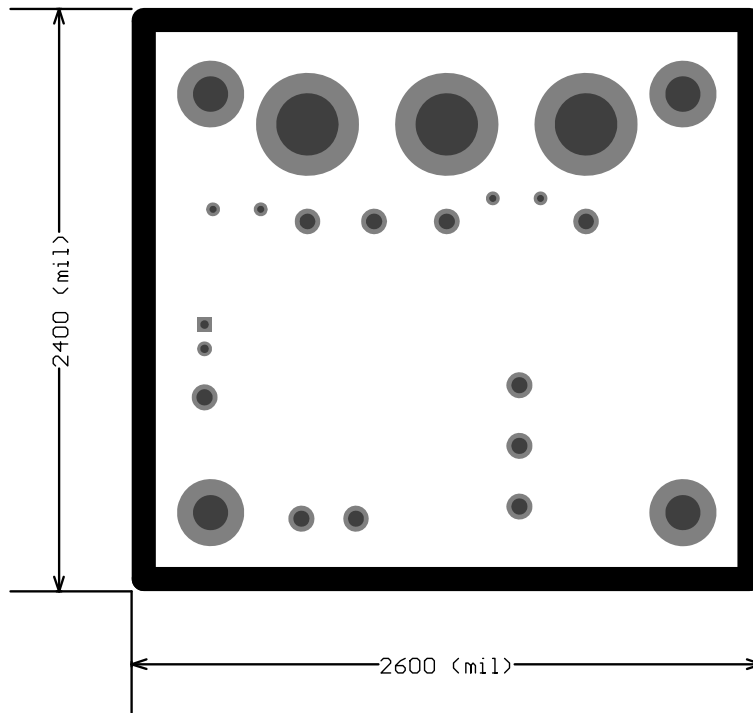

Bottom Assembly

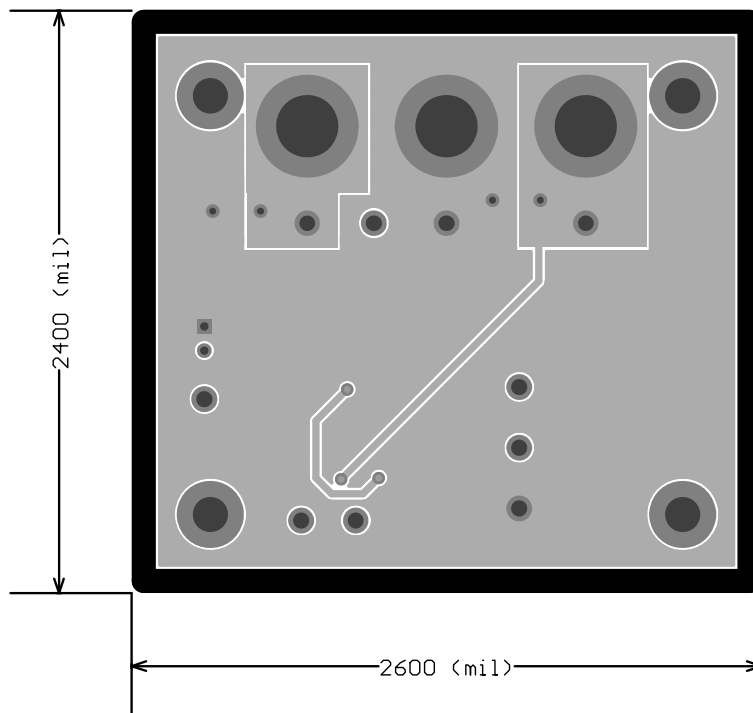

Bottom Layer

MICREL, INC. 2180 FORTUNE DRIVE SAN JOSE, CA 95131 USA
TEL +1 (408) 944-0800 FAX +1 (408) 474-1000 WEB <http://www.micrel.com>

The information furnished by Micrel in this data sheet is believed to be accurate and reliable. However, no responsibility is assumed by Micrel for its use. Micrel reserves the right to change circuitry and specifications at any time without notification to the customer.

Micrel Products are not designed or authorized for use as components in life support appliances, devices or systems where malfunction of a product can reasonably be expected to result in personal injury. Life support devices or systems are devices or systems that (a) are intended for surgical implant into the body or (b) support or sustain life, and whose failure to perform can be reasonably expected to result in a significant injury to the user. A Purchaser's use or sale of Micrel Products for use in life support appliances, devices or systems is a Purchaser's own risk and Purchaser agrees to fully indemnify Micrel for any damages resulting from such use or sale.

© 2008 Micrel, Incorporated.