

Li+ battery charger with thermal regulation

Datasheet – production data

Features

- Programmable charge current up to 1.1 A
- Floating voltage limitation outside the safety temperature range
- PSE fully compatible
- Low battery voltage detection for pre-charge setting
- Automatic recharge
- Two charge status output pins
- Constant current / constant voltage operation
- No external MOSFET, sense resistors or blocking diode required
- Reverse current blocking (50 μ A max.)
- Short-circuit protection and thermal shutdown
- Less than 1 mA supply current in standby mode
- Reversed battery polarity protection
- I²C interface for charging parameters programming
- ESD: HBM \pm 2 kV, CDM 500 V on every pin
- HTSSOP-14 (5 x 4.4 mm) package available
- -25 °C to 125 °C operative junction temperature

Description

The STBC21 is a constant current/constant voltage charger for single cell Li-Ion batteries. Most of the charging parameters, including floating voltage, pre-charge and termination current are programmable in NVM memory. While fast charging current is programmed using an external resistor. The constant current process is split into three phases depending on the battery voltage. If the battery voltage is below 3.0 V, the charging current is set to a programmable value below 200 mA. A timeout of 60 minutes is used in this phase to detect faulty batteries. When the battery voltage goes above 3.0 V, the charger



moves to the fast-charge procedure with a current programmable by an external resistor up to 1.1 A. When the battery reaches the value of the floating voltage the charger enters “constant voltage” mode. Even in this mode a protection timer is active to avoid risks due to damaged batteries. The charge cycle is automatically terminated when the current flowing to the battery reaches the value programmed in NVM. There is also a programmable lag time after the termination to maximize the battery charge. An internal block regulates the battery floating voltage when its temperature is outside the safety range between 10 °C and 45 °C, (JEITA/PSE regulation). The floating voltage inside the safety range is set, by default, at 4.2 V. If the external power supply is removed, the STBC21 turns off and a 50 μ A (max.) current can flow from the battery to the device. The device also has an undervoltage lockout and automatic recharge capability which can be enabled/disabled by setting a bit in NVM. Two separate status pins allow a lot of information to be gotten based also on flashing frequency and duty cycle. The STBC21 also includes a reversed battery polarity protection to prevent damage due to incorrect battery insertion. The package is a HTSSOP-14 (5 x 4.4).

Table 1. Device summary

Order code	Package	Packaging
STBC21FTR	HTSSOP-14	Tape and reel

Contents

1	Block diagram	6
2	Pin configuration	8
3	Maximum ratings	9
4	Electrical characteristics	10
5	Detailed description	13
5.1	Operation mode	14
5.2	Battery connection detection	15
5.3	Start of charge	16
5.4	Fast-charge programming	17
5.5	Charge auto-limitation	17
5.6	PHC pin functionality	21
5.7	Alarms	22
5.8	Reversed battery polarity protection	25
5.9	Temperature protection	25
5.10	I ² C data transfer	26
5.10.1	Sequential registers write:	27
5.10.2	Sequential registers read:	28
6	ESD requirements	29
Appendix A Register configuration and access mode description		30
Appendix B Charging parameters		31
Appendix C Charging control		36
Appendix D Temperature thresholds		37
Appendix E LED configurations diversified for customer (each customer one pattern)		40

Appendix F	LED display modes	42
Appendix G	NVM commands register	46
Appendix H	Charger, battery and alarm status registers	47
	H.1 Layout guidelines	49
7	Package mechanical data	51
8	Revision history	53

List of tables

Table 1.	Device summary	1
Table 2.	External components	7
Table 3.	Pin description	8
Table 4.	Absolute maximum ratings	9
Table 5.	Thermal data	9
Table 6.	Electrical characteristics (DC)	10
Table 7.	Start of charge	17
Table 8.	Write single register	26
Table 9.	Read single register	27
Table 10.	Configuration registers map	30
Table 11.	Control registers map	30
Table 12.	Timer registers summary	31
Table 13.	Timer-2 description	31
Table 14.	Timer-3 description	32
Table 15.	Charging current registers	32
Table 16.	SET1 register description	32
Table 17.	ISET3 register description	33
Table 18.	Constant voltage register	33
Table 19.	CV1 bit description	33
Table 20.	CV2 bit description	34
Table 21.	CV3 bit description	34
Table 22.	CV4 bit description	34
Table 23.	Halving register	34
Table 24.	ISET2 (CV1) bit description	34
Table 25.	ISET2 (CV2) bit description	35
Table 26.	ISET2 (CV3) bit description	35
Table 27.	ISET2 (CV4) bit description	35
Table 28.	Charging control	36
Table 29.	Auto recharge bit description	36
Table 30.	Temperature thresholds	37
Table 31.	Th-h reg	37
Table 32.	Th reg	38
Table 33.	Tl reg	39
Table 34.	Hys reg	39
Table 35.	LED configurations	40
Table 36.	LED display modes	42
Table 37.	LED frequency register	42
Table 38.	LED duty cycle register	43
Table 39.	Address: 10H, Reset state: 00000000	46
Table 40.	NVM commands	46
Table 41.	Address: 11H, Reset state: 00000000	47
Table 42.	Address: 12H, Reset state: 00000000	47
Table 43.	Address: 13H, Reset state: 00000000	48
Table 44.	Digital charger status	48
Table 45.	Address: 14H, Reset state: 00000000	48
Table 46.	Battery temperature range	49
Table 47.	HTSSOP-14L (5 x 4.4 mm) mechanical data	51
Table 48.	Document revision history	53

List of figures

Figure 1.	Block diagram	6
Figure 2.	Typical application schematic	7
Figure 3.	Pin connections (top through view)	8
Figure 4.	Charging process flowchart	14
Figure 5.	Battery connection detection flowcharts	16
Figure 6.	Temperature ranges compatible with PSE, power safety electrical	18
Figure 7.	V-I characteristics	19
Figure 8.	Battery temperature alarm after charging starts (at battery insertion and at recharge) flowchart	19
Figure 9.	Battery temperature alarm during charge flowchart	20
Figure 10.	Temperature detector schematic	20
Figure 11.	Charging process diagram	21
Figure 12.	Charging process diagram	22
Figure 13.	Battery alarm flowchart	24
Figure 14.	Charger alarm flowchart	24
Figure 15.	LEDs control circuit	25
Figure 16.	Junction shutdown temperature detection	26
Figure 17.	Layout board (top through view)	49
Figure 18.	Layout board (top view)	50
Figure 19.	Drawing dimension HTSSOP-14L (5 x 4.4 mm)	52

1 Block diagram

Figure 1. Block diagram

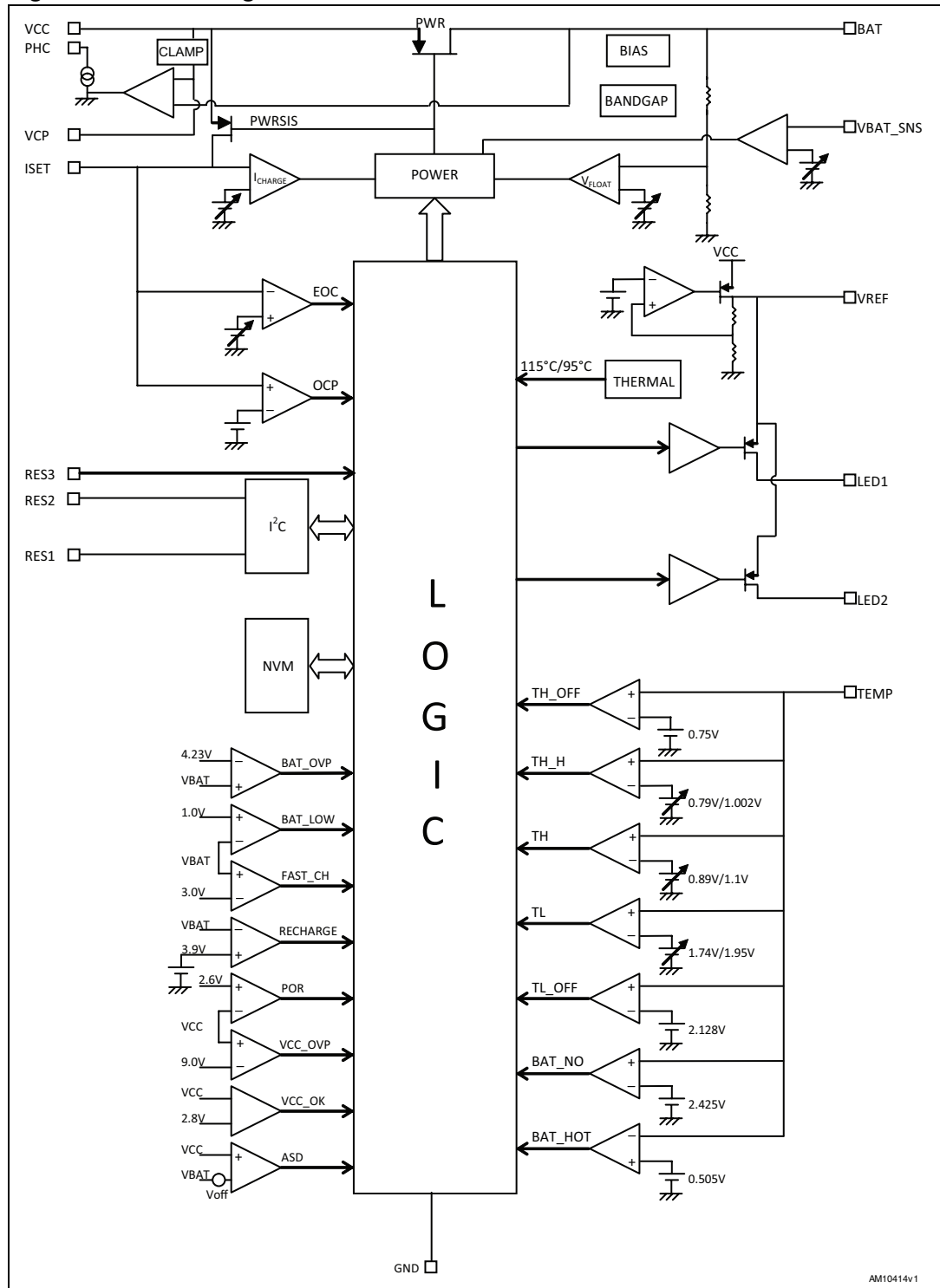

Figure 2. Typical application schematic

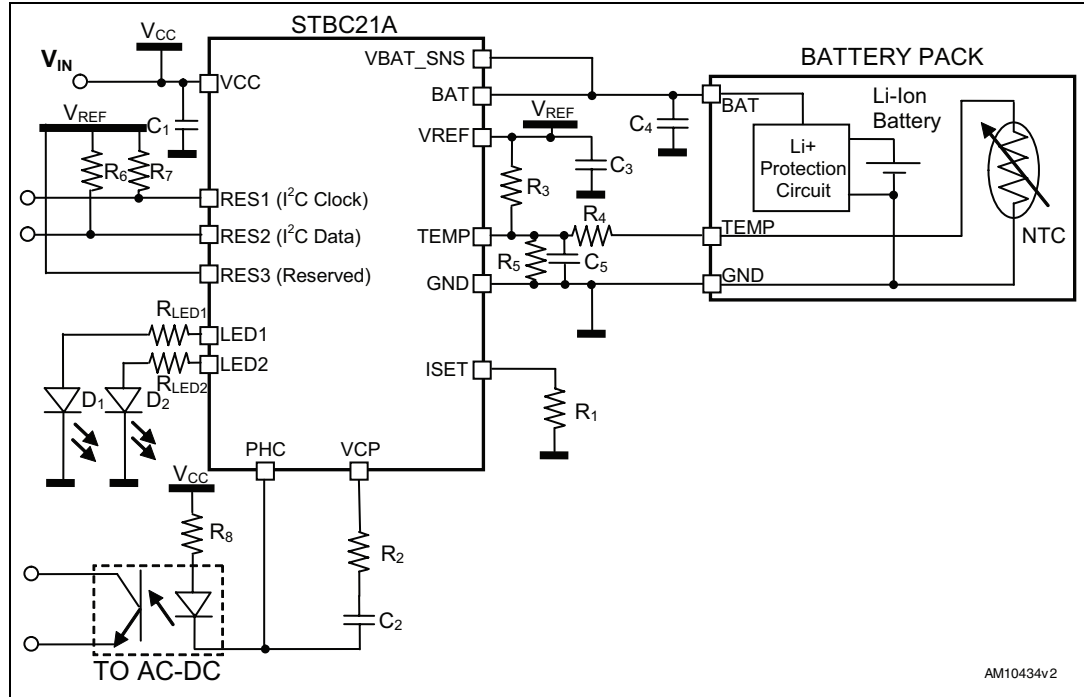

Table 2. External components

Symbol	Parameter	Min.	Typ.	Max.	Unit
C ₁	Ceramic capacitor SMD	1		10	μF
C ₂	Ceramic capacitor SMD		TBD		μF
C ₃	Ceramic capacitor SMD		0.1		μF
C ₄	Ceramic capacitor SMD		10		μF
C ₅	Ceramic capacitor SMD		TBD ⁽¹⁾		
R ₁	Resistor		10 ⁽²⁾		kΩ
R ₂	Resistor		TBD		kΩ
R ₃	Resistor		100		kΩ
R ₄	Resistor		0		Ω
R ₅	Resistor		TBD ⁽¹⁾		
R ₆	Resistor		4.7		kΩ
R ₇	Resistor		4.7		kΩ
R ₈	Resistor		TBD ⁽³⁾		
R _{LED1} , R _{LED2}	Resistor		90		Ω
D ₁	LED Kingbright L-934HD				
D ₂	LED Kingbright L-934GD				

1. Time constant R5*C5 must be less than 20 msec.
2. This value refers to a fast-charge current of 100 mA.
3. Time constant must be chosen taking into account compensation loop.

2 Pin configuration

Figure 3. Pin connections (top through view)

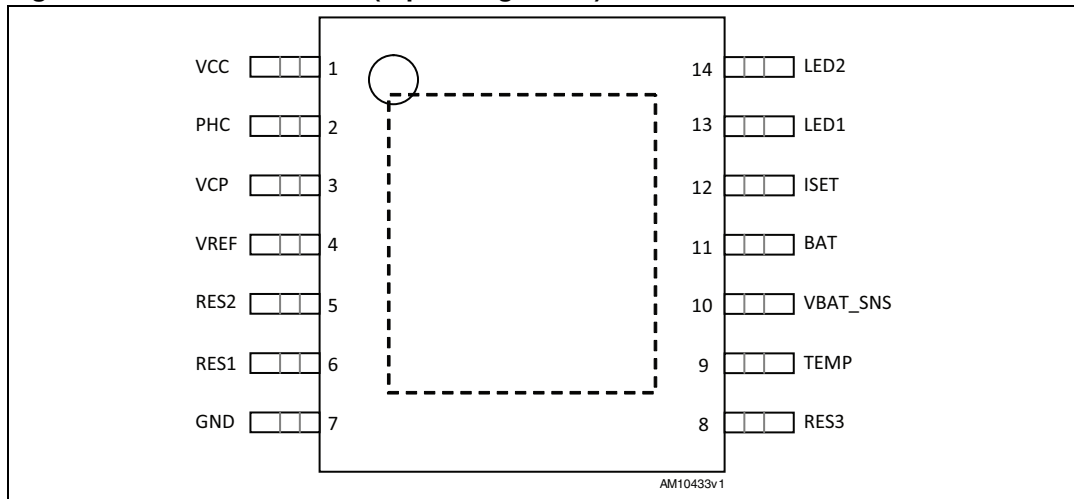

Table 3. Pin description

Pin n°	Symbol	Function
1	VCC	Input supply voltage
2	PHC	Photo coupler driver
3	VCP	Compensation pin
4	VREF	Voltage reference for external NTC
5	RES2	I ² C bi-directional data - pulled high
6	RES1	I ² C clock - pulled high
7	GND	Ground pin
8	RES3	Reserved
9	TEMP	Input from temperature sensor
10	VBAT_SNS	Battery voltage sensing
11	BAT	This pin provides an accurate output voltage and the charge current following the charging algorithm. Only 50 μA reverse current can flow into the device when in standby mode
12	ISET	Fast-charge current setting
13	LED1	Open drain. See Appendix E & F
14	LED2	Open drain. See Appendix E & F
	EXPOSED PAD	Not connected

3 Maximum ratings

Table 4. Absolute maximum ratings

Symbol	Parameter	Value	Unit
V_{CC}	Input supply voltage	From -0.3 to 10	V
V_{BAT} , V_{BAT_SNS}	Battery voltage	From -6.0 to 6.0	V
V_{PHC}	PHC voltage	From -0.3 to 10	V
V_{VCP}	VCP voltage	From -0.3 to 5.5	V
V_{REF}	REF voltage	From -0.3 to 3.6	V
V_{LV}	TEMP, LED1, LED2, ISET	From -0.3 to $V_{REF}+0.3$	V
V_{RES}	RES1, RES2, RES3	From -0.3 to 3.6	V
I_{BAT}	Charging battery current	1350	mA
ESD	Electrostatic discharge voltage (according to HBM JESD22-A114D)	± 2	kV
	Electrostatic discharge voltage (according to CDM JESD22-C101C)	500	V
T_{STG}	Storage temperature range	-65 to 150	$^{\circ}C$
T_J	Junction temperature range	-40 to 125	$^{\circ}C$
Lead temperature	(soldering, 10 seconds)	300	$^{\circ}C$

Note: Absolute maximum ratings are those values beyond which damage to the device may occur. Functional operation under these conditions is not implied. All values are referred to GND.

Table 5. Thermal data

Symbol	Parameter	Value	Unit
$R_{thJA}^{(1)}$	Thermal resistance junction-ambient	37.6 ⁽²⁾	$^{\circ}C/W$

1. Evaluated on 1S2P (1 signal, 2 plane layers) board, 4.4 x 5 mm body size, 3.0 x 3.0 mm pad size, 1.5 W applied power.
2. By 0 velocity (linear feet per minute). This value drops to 30.2 $^{\circ}C/W$ by 500 velocity.

4 Electrical characteristics

$T_J = -25\text{ °C}$ to 85 °C unless otherwise specified. Refer to the typical application circuit.
Typical values are referred to $T_J = 25\text{ °C}$.

Table 6. Electrical characteristics (DC)

Symbol	Parameter	Conditions	Min.	Typ.	Max.	Unit
V_{CC}			2.6		9.0	V
V_{CC_USB}	Minimum V_{CC} to enable charging without quasi-pulse			4.5		V
V_{BAT}			3.0		4.25	V
I_{CC}	Supply current (excluding LEDs and battery current)	Fast charge ⁽¹⁾ 3.0 V < V_{CC} < 9.0 V $I_{BAT}=100\text{ mA}$			750	μA
		Shutdown 2.6 V < V_{CC} < 2.85 V			80	μA
		Standby (charge terminated) 2.8 V < V_{CC} < 9.0 V			450	μA
I_{STBY}	I_{BAT} standby current (charge terminated)	0 V < V_{CC} < 9.0 V $V_{BAT}=4.2\text{ V}$ $V_{TEMP}=1.2\text{ V}$			-50	μA
I_{PRE_CH}	Nominal pre-charge / 0V-charge current	2.8 V < V_{CC} < 9.0 V	48	60	72	mA
			72	90	108	
			96	120	144	
I_{F_CH}	Nominal fast-charge current	Set by Ext. resistor $R_1=1.25\text{ k}\Omega$	744	800	856	mA
I_{TERM}	Charge termination current	10 mA steps from 40 mA to 190 mA 4.5 V < V_{CC} < 9.0 V $V_{BAT}=4.2\text{ V}$, $TIMER3=0$	32	40	48	mA
			152	190	228	
I_{BAT_OCP}	I_{BAT} overcurrent protection			1.35		A
I_{VREF}	V_{REF} current limit	5.0 V < V_{CC} < 9.0 V		30		mA
I_{PHC}	Photo-coupler current	$V_{CC}=5.0\text{ V}$, $V_{BAT}=3.0\text{ V}$		10		mA
I_{LK_PHC}	Photo-coupler leakage	$V_{CC}=5.0\text{ V}$, $V_{BAT}=4.8\text{ V}$, $V_{PHC}=5.0\text{ V}$		2		μA
I_{SINK}	Sunk current during battery detection	$C_{OUT}=10\text{ }\mu\text{F}$		1		mA
I_{DETECT}	Sunk current during battery detection	$C_{OUT}=10\text{ }\mu\text{F}$		1		mA
I_{LED}	LED current	$V_{REF}=2.9\text{ V}$, $V_{FLED}=2\text{ V}$ $R_{LED}=90\text{ k}\Omega$		10		mA
V_{CC_POR}	Power-on reset threshold		2.47	2.6	2.73	V

Table 6. Electrical characteristics (DC) (continued)

Symbol	Parameter	Conditions	Min.	Typ.	Max.	Unit
V _{CC_OK}	Charging start threshold – V _{CC} undervoltage alarm (V _{CC_UVLO})	±5%	2.66	2.8	2.94	V
V _{CC_ASD}	V _{CC} -V _{BAT} threshold			125		mV
V _{CC_OVP}	V _{CC} overvoltage protection		8.55	9.0	9.45	V
I _{ODROP_QP}	Quasi-pulse V _{CC} -V _{BAT} drop	I _{BAT} =100 mA, I _{BAT} =1.0A			0.35	V
V _{OV_HD}	0V-charge threshold	±5%		1		V
V _{PRE_CH}	Pre-charge to fast-charge voltage threshold	V _{CC} = 5.0 V		3.0		V
ΔV _{FLT}	Float voltage range tolerance	V _{FLT} = 4.2 V, I _{BAT} = 1 mA T _J = -10 °C to 85 °C	-0.7		0.7	%
V _{FLT_OVP}	Float voltage OVP	5.0 V < V _{CC} < 9.0 V T _{BAT} = 0 °C to 60 °C I _{BAT} = 1.0 mA TIMER-3 = 60 min.	4.21	4.23	4.25	V
V _{CC_QP}	Quasi-pulse minimum supply voltage in pre-charge phase			3.1		V
V _{BAT_QP}	Minimum battery voltage to start quasi-pulse mode			2.8		V
V _{RECH}	Battery recharge threshold voltage	5.0 V < V _{CC} < 9.0 V		3.9		V
V _{TEMP_UN}	NTC voltage threshold for battery unconnected	±2%		2.425		V
V _{TEMP_OT}	NTC voltage threshold for battery overtemperature	±2%		0.505		V
V _{REF}	Reference voltage for NTC / LED drive voltage	±5%		2.9		V
R _{DS-ON}	Power MOS saturation resistance	0 °C < T _J < 85 °C		300		mΩ
T _{RECH}	Battery recharge deglitching time	V _{CC} = 5.0 V		100		ms
T _{FULL}	Full charge detection deglitching time (after termination)	V _{CC} = 5.0 V – TIMER-3 = 0		100		ms
T _{HV}	Battery overvoltage detection deglitching time	V _{CC} = 5.0 V		100		ms
T _{HI}	Overcurrent detection deglitching time	V _{CC} = 5.0 V		100		ms
T _{HOLD_OFF}	Deglitching time on V _{CC} to start charging (V _{CC} =3.0 V)	V _{BAT} = 2.8 V		10		ms
T _{BAT_HOT}	Battery hot detection deglitching time	V _{CC} = 5.0 V		10		ms
T _{BAT_CON}	Battery connection detection deglitching time	V _{CC} = 5.0 V		400		ms
T _{BAT_TLO}	Battery T _{LO} temperature detection deglitching time	V _{CC} = 5.0 V		100		ms

Table 6. Electrical characteristics (DC) (continued)

Symbol	Parameter	Conditions	Min.	Typ.	Max.	Unit
T _{BAT_THO}	Battery T _{HO} temperature detection deglitching time	V _{CC} = 5.0 V		100		ms
T _{BAT_TL}	Battery T _L temperature detection deglitching time	V _{CC} = 5.0 V		100		ms
T _{BAT_TH}	Battery T _H temperature detection deglitching time	V _{CC} = 5.0 V		100		ms
T _{BAT_THH}	Battery T _{HH} temperature detection deglitching time	V _{CC} = 5.0 V		100		ms
T _{SINK}	Duration of battery connection detection	C _{OUT} = 10 μF		100		ms
T _{DETECT}	Duration of battery connection detection	C _{OUT} = 10 μF		300		ms
TIMER-1	Pre-charge timer	± 10% @ 25 °C ±15% in temp range		60		min
TIMER-2	Fast-charge timer (programmable)	± 10% @ 25 °C ±15% in temp range	150		510	min
TIMER-3	Termination timer (programmable)	± 10% @ 25 °C ±15% in temp range	0		60	min
TIMER-4	0 V-charge timer	± 10% @ 25 °C ±15% in temp range		16		sec
T _{J_SH}	Junction shutdown temperature	20 °C hysteresis		115		°C
T _L	Lower limit of safety range	10 °C	1.74		1.95	V
T _H	Upper limit of safety range	45 °C	0.89		1.10	V
T _{HH}	Intermediate safety range	50 °C	0.79		1.002	V
T _{HO}	Upper limit of functional range	60 °C	0.727	0.75	0.776	V
T _{LO}	Lower limit of functional range	-2 °C	2.087	2.128	2.168	V
Hysteresis		2 °C		28		mV
		5 °C		70		mV

5 Detailed description

The STBC21 is designed to charge single-cell lithium-ion batteries using the constant current/constant voltage algorithm. The charger can deliver up to 1.1 A (programmable) of charge current with a final float voltage accuracy of 20 mV.

Once the battery is connected, the normal charge cycle begins when the voltage at the V_{CC} pin rises above the threshold (V_{CC_OK}).

The process generally starts with a pre-charge phase in constant current mode, where a reduced charge current (see [Appendix B](#)) is supplied to the battery. A programmable timer (TIMER-1) during this phase allows possibly damaged batteries to be spotted in case the voltage doesn't reach the expected value within a given time.

Note that, if the battery voltage is below 1.0 V, the charger first attempts to charge (0 V-charge mode) for 16 seconds (TIMER-4) to test if the battery is dead. After the TIMER-4 has elapsed, in case the voltage doesn't cross the 1.0 V threshold, a battery alarm is flagged. Otherwise the charger keeps on charging.

When the battery voltage reaches 3.0 V, the charging current reaches its maximum value (fast-charge phase) programmable by an external resistor.

When the battery voltage approaches the final float voltage (programmable, typ. 4.2 V), the STBC21 enters constant voltage mode and the charge current decreases as the battery becomes fully charged. The fast-charge and the following constant voltage phases have a dedicated timer set through bits in NVM to make sure the current reaches its termination value within a given time. If during this phase the battery voltage falls below V_{PRE_CH} or rises above 4.23 V (± 20 mV), the operation is stopped and an alarm sounds.

The STBC21 terminates the constant voltage phase when the charging current reaches the termination current threshold (value set in ISET3 register, see [Appendix B](#)). In addition, a further step (end of charge) can be activated through bits in NVM. In this case, the charging process in constant voltage mode continues for a predefined amount of time (TIMER-3): this behavior is useful to increase the battery duration.

After charge termination the battery may be discharged by the leakage. When the battery voltage reaches V_{RECH} with a lag time of 100 ms the charge automatically restarts. This feature can be disabled setting a bit in NVM.

If, during the charging phase, one of the timeouts elapses, the charge is stopped and a flag is set. See [Appendix B](#) for more details on timers. The STBC21 charging process works as depicted in [Figure 4](#).

5.2 Battery connection detection

The STBC21 includes a battery detection algorithm to avoid a wrong behavior of the charger due to incorrect pin connection. This control is performed both at the beginning and at the end of charge.

At the beginning of charge, the charger briefly (T_{DETECT}) sources a small current (I_{DETECT}) to the battery: if the voltage remains below V_{RECH} , the battery is definitely connected. Otherwise, if the voltage reaches V_{RECH} , a further control is added to be sure the battery is not connected. The charger briefly sinks (T_{SINK}) a small current (I_{SINK}) from the battery. If voltage falls below $V_{\text{PRE_CH}}$, the battery is certainly absent.

Similarly, when the termination current is reached, the charger briefly (T_{SINK}) sinks a small current (I_{SINK}) from the battery. After this period, if the battery voltage is above $V_{\text{PRE_CH}}$, the battery is present. Otherwise the battery is absent. The flowcharts in [Figure 5](#) better explain this algorithm.

Figure 5. Battery connection detection flowcharts

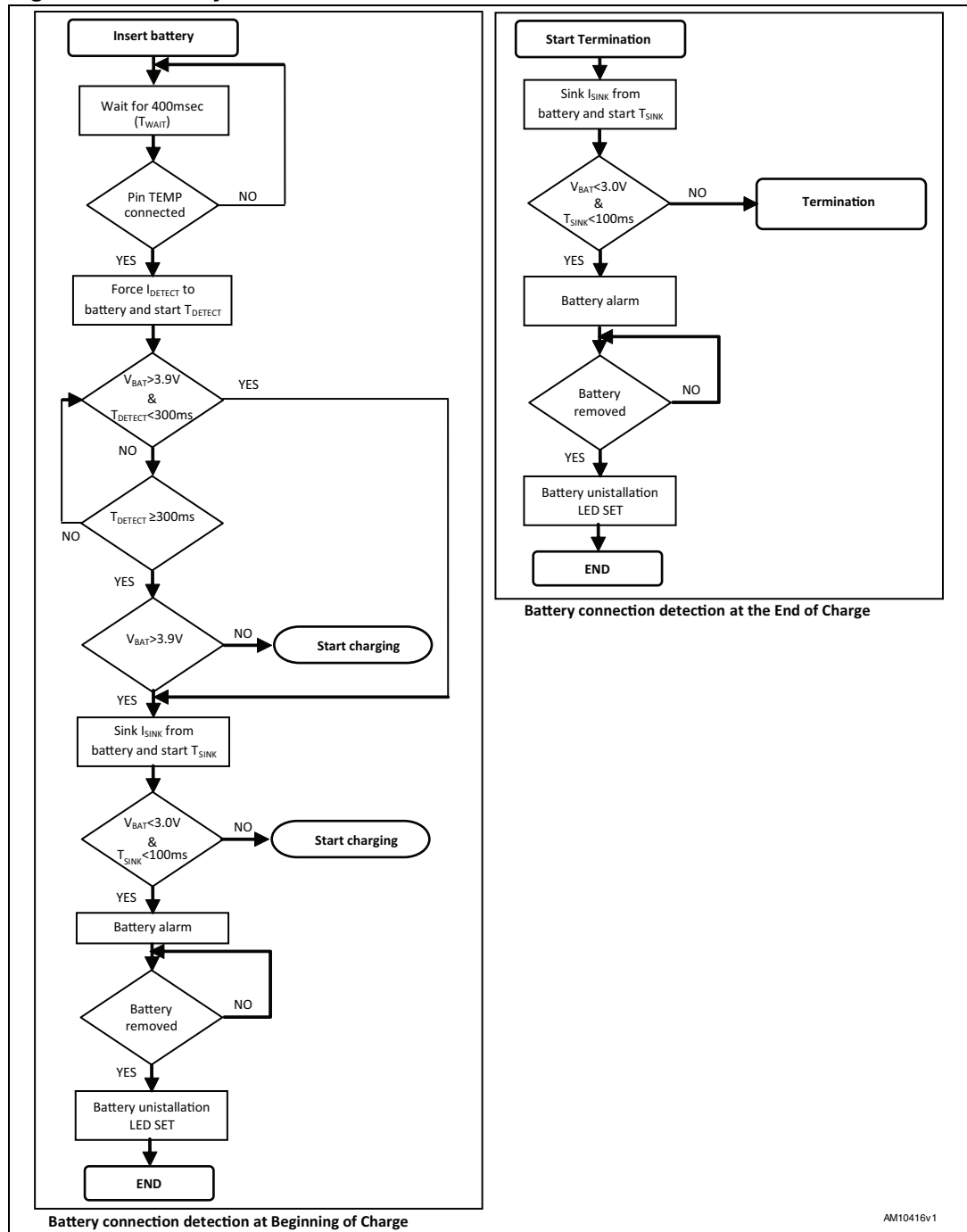

5.3 Start of charge

The STBC21 start of charge is subject to three variables: input voltage, battery connection and battery temperature. The detection of these variables is filtered with different deglitching as reported in [Table 7](#):

Table 7. Start of charge

Item	Delay	Enabling condition
Battery connection detection	400 ms	$V_{TEMP} < 2.425 \text{ V}$
V_{CC} voltage detection	10 ms	$V_{CC} > 2.8 \text{ V}$
Battery temperature detection	100 ms	$0.75 \text{ V} < V_{TEMP} < 2.128 \text{ V}$

The charge starts if V_{CC} exceeds 2.8 V, the battery is connected and its temperature is in the safety range (see [Section 5.5](#)).

In addition, the charge cycle starts if the available supply voltage exceeds by V_{CC-ASD} the BAT pin voltage level.

The start of charge in case of a discharged battery is already described in a previous paragraph. Meanwhile, if a fully charged battery is connected, the charge starts in constant voltage mode with TIMER-2 associated.

5.4 Fast-charge programming

When the battery voltage reaches the pre-charge voltage threshold, the STBC21 starts the fast-charge phase. In this phase, the device charges the battery with a constant current, programmable by an external resistor that sets the charge current. The formula used to select the RPRG is as follows:

Equation 1

$$R_{PRG} = V_{SET} \times \left(\frac{K_{PRG}}{I_{CHG}} \right)$$

where $V_{SET} = 1.0 \text{ V}$ and $K_{PRG} = 1000$. During this phase, the battery voltage increases until it reaches the programmed floating voltage or the safety timer expires and the alarm is activated.

5.5 Charge auto-limitation

The STBC21 includes an auto-limitation algorithm to avoid explosion risks in the Li+ battery. This algorithm makes sure that the battery is never charged at its maximum floating voltage if the temperature is above 45 °C or below 10 °C.

Three more ranges are defined outside the safety range T_L - T_H (10 °C ~ 45 °C) as reported in [Figure 6](#).

Figure 6. Temperature ranges compatible with PSE, power safety electrical

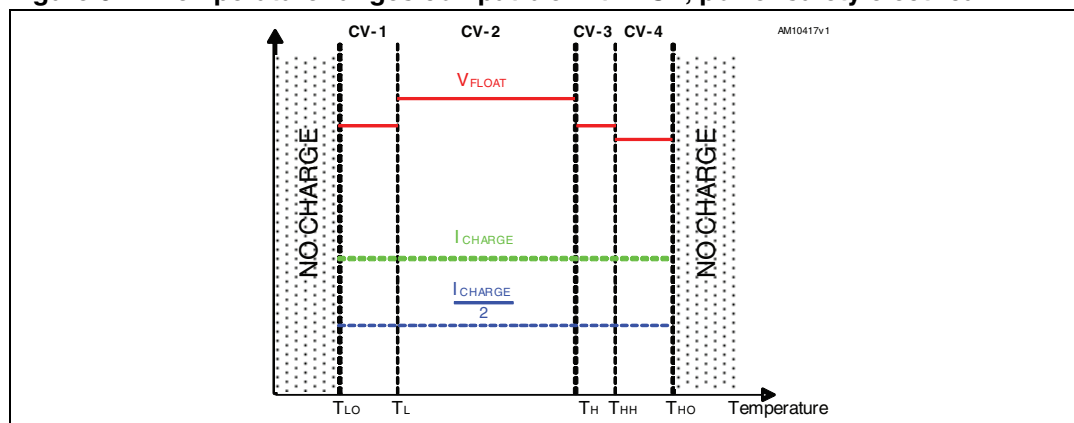

The new floating voltage in these ranges can be programmed to be 4.2 V, 4.1 V or 4.05 V (± 30 mV), as reported in [Appendix B](#).

Once the reduced floating voltage is reached, the charge terminates only if the battery temperature is in the 10 °C ~ 45 °C range. If the temperature is outside this range, the charger holds and restarts once the temperature decreases.

This function can be enabled/disabled setting a bit in NVM.

There is also the possibility to halve the charging current (see [Figure 6](#), blue dashed line) in fast-charge in all temperature ranges.

In addition, all thresholds have an hysteresis: T_{LO} and T_{HO} have a fixed hysteresis of 2 °C, whereas T_L , T_H and T_{HH} have a programmable hysteresis of 2 °C or 5 °C (value set by a bit in NVM).

If the temperature moves above T_H or below T_L , V_{float} is reduced. When the temperature goes back inside the range T_L - T_H (with the associated hysteresis), V_{float} is replaced to its maximum value.

At the beginning of the charge, when the battery pack is inserted, a check of battery temperature is performed: if the temperature is outside the range 0 °C~45 °C, the charger doesn't start charging and waits until the temperature goes back into the range (above 0 °C or below 43 °C) (see [Figure 8](#)).

Similarly, if auto-recharge is active and battery voltage decreases below 3.9 V, but its temperature is outside the range 0 °C ~ 45 °C, the charge is stopped and restarts only when battery temperature goes into the range 0 °C ~ 43 °C. In this situation, LEDs continue to show “charge completed”.

During charging, if battery temperature goes outside the functional range (-2 °C ~ 60 °C), the charger must stop the operations regardless of the current state. In this case, the LEDs show “Battery temperature alarm” but the timers keep on counting. If the temperature moves back inside the range 0 °C ~ 43 °C, the charger restarts the operations restoring the status it was in before the interruption.

In this case, if temperature goes above 60 °C twice, the charger stops, the LEDs show a “charge completed” and it is necessary to remove the battery to restart the operations (see [Figure 9](#)). With the battery uninstalled, the LED configuration is like that indicated in [Appendix E](#).

In summary, the STBC21 behavior can also be represented as the following V-I characteristic:

Figure 7. V-I characteristics

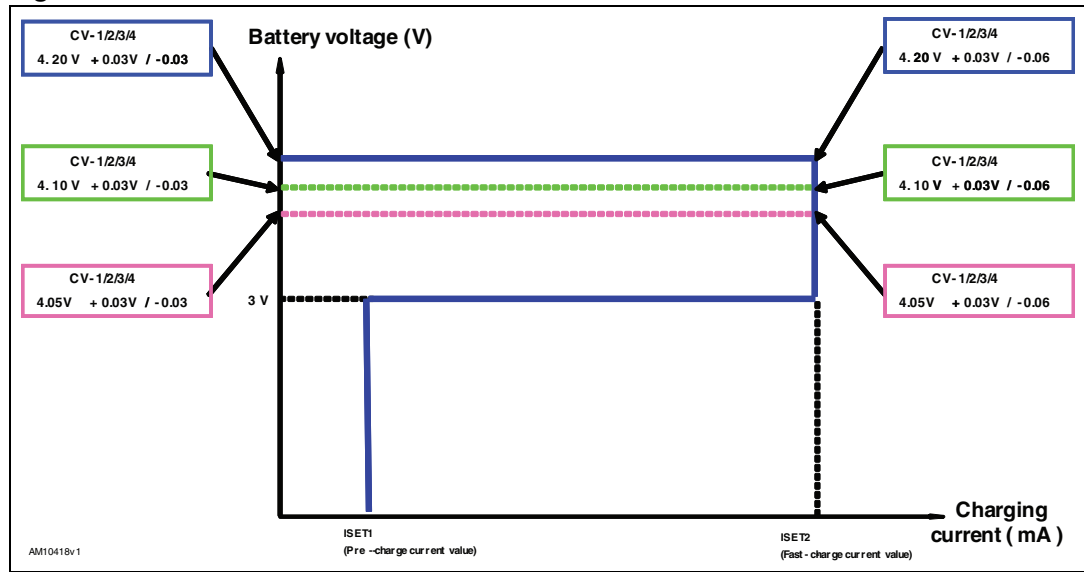

Figure 8. Battery temperature alarm after charging starts (at battery insertion and at recharge) flowchart

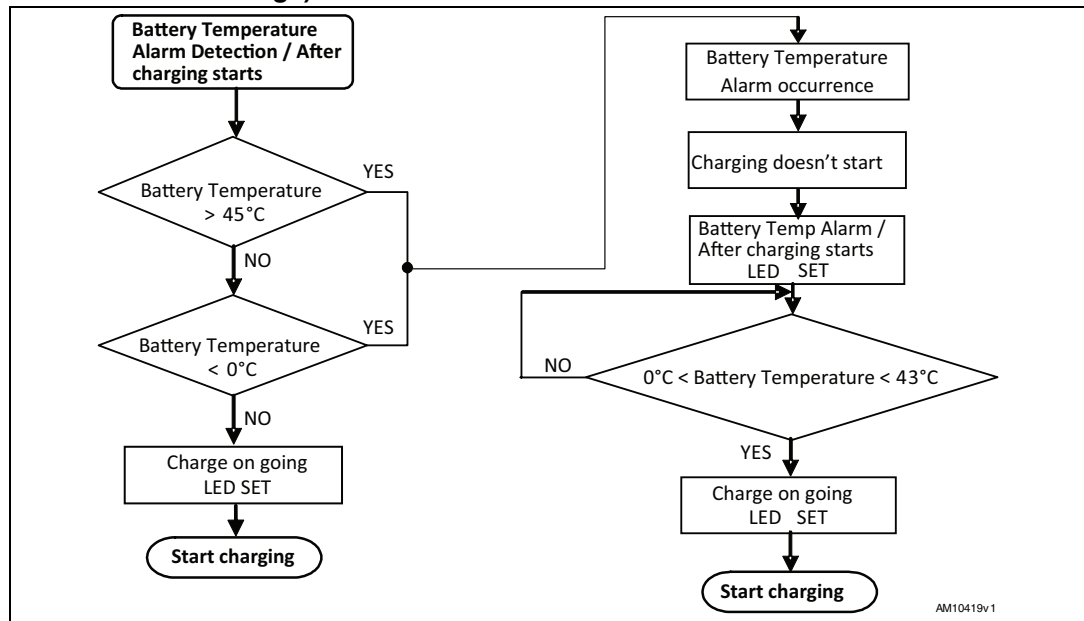
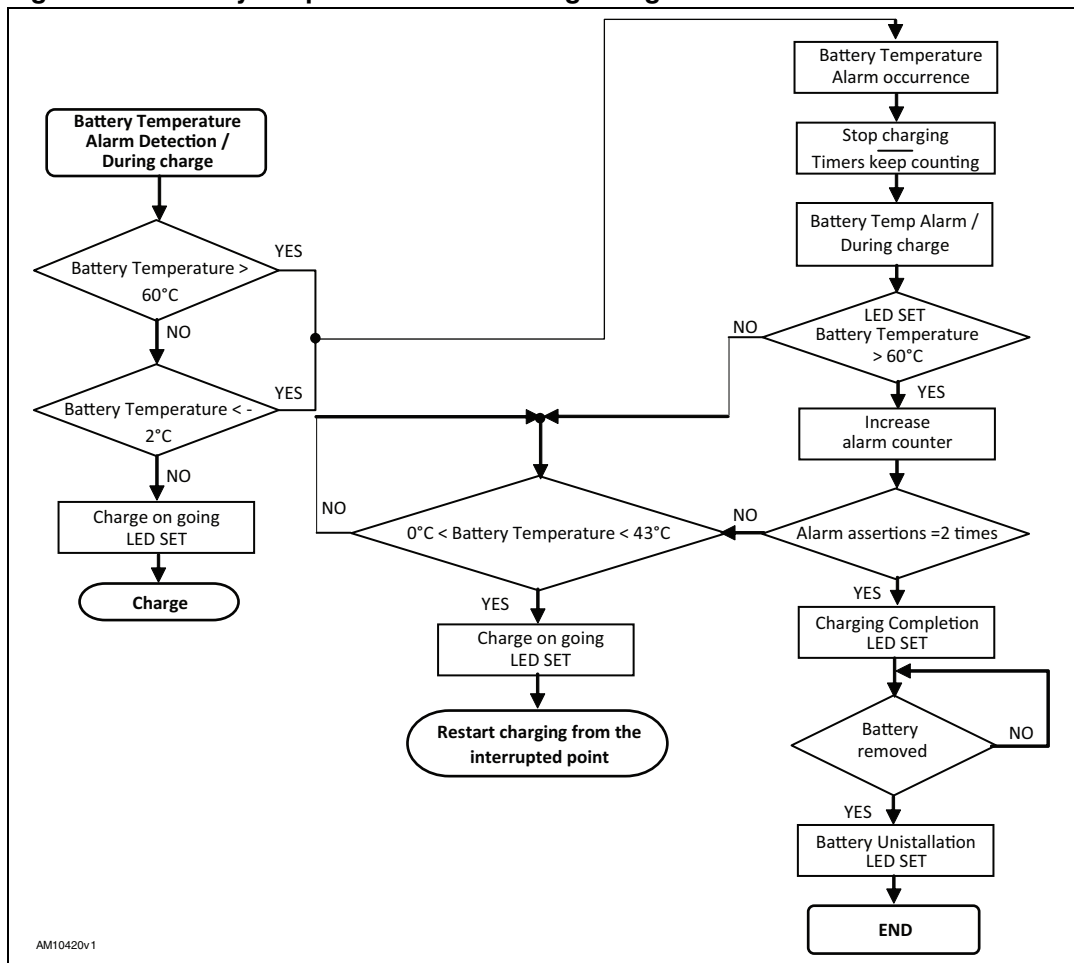

Figure 9. Battery temperature alarm during charge flowchart



The chip also includes an NVM to allow the temperature thresholds above to be programmable few times by the battery manufacturer.

The temperature thresholds are sensed by the NTC inside the battery pack. A reference voltage is properly partitioned to translate the variable resistance in a variable voltage as shown in [Figure 10](#).

Figure 10. Temperature detector schematic

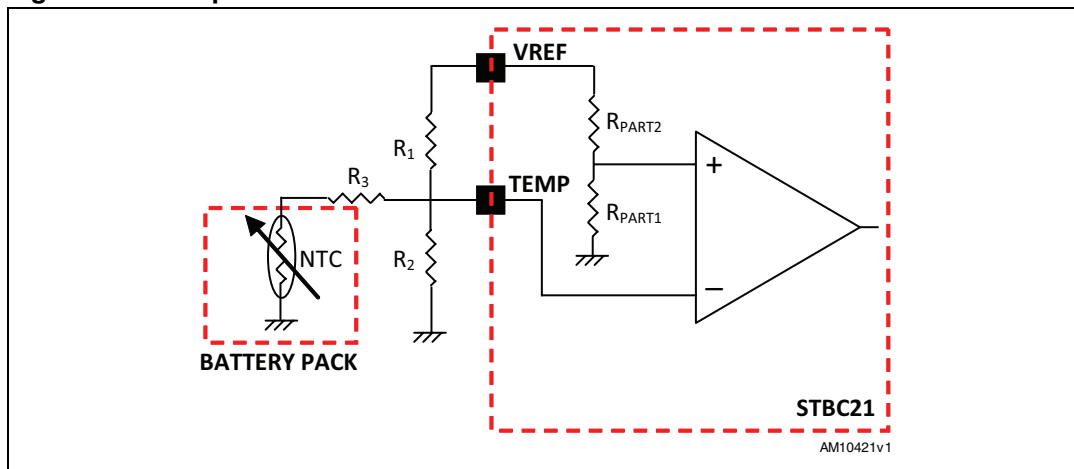

Using an integrated resistor partition and a very low-offset comparator, it's possible to detect a battery temperature value that doesn't depend on reference voltage, but is affected by an internal resistor divider matching only.

As regards NTC, the components suggested are:

1. NTC1 PANASONIC $R_{25} = 100\text{ k}\Omega \pm 1\%$ $B_{25/85}=4700\text{ K} \pm 1\%$ (code ERTJ0EV104F)
2. NTC2 PANASONIC $R_{25} = 10\text{ k}\Omega \pm 1\%$ $B_{25/85}=3435\text{ K} \pm 1\%$ (code ERTJ0EG103FA)

Two resistor networks are proposed to implement linearization of these two NTCs, as written below.

NTC1: $R_1 = 100\text{ k}\Omega - R_2 = 700\text{ k}\Omega - R_3 = 17.8\text{ k}\Omega$

NTC2: $R_1 = 9.1\text{ k}\Omega - R_2 = 160\text{ k}\Omega - R_3 = 0.22\text{ k}\Omega$

In this way, voltage thresholds of similar value for both NTCs are obtained. The STBC21 automatically recognizes these voltage thresholds.

$T_{LO} (-2\text{ }^\circ\text{C})$	$T_L (10\text{ }^\circ\text{C})$	$T_H (45\text{ }^\circ\text{C})$	$T_{HH} (50\text{ }^\circ\text{C})$	$T_{HO} (60\text{ }^\circ\text{C})$
2.128 V	1.74 V - 1.95 V	0.89 V - 1.1 V	0.79 V - 1.002 V	0.75 V

5.6 PHC pin functionality

The time diagram of the charging process can be summarized in the image below:

Figure 11. Charging process diagram

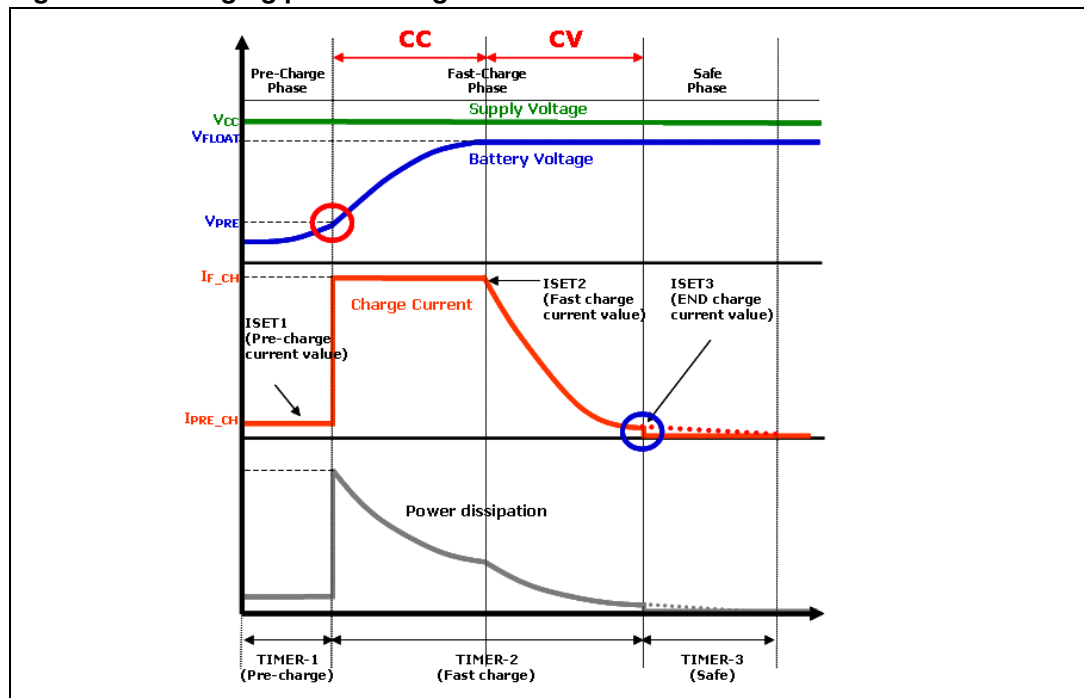

As shown, in fast-charge phase the power dissipation can be important and supposing $V_{IN} = 9.0\text{ V}$ and $I_{BAT} = 1.1\text{ A}$:

Equation 2

$$P = (V_{IN} - V_{OUT}) \times I_{BAT} = 6.6W$$

which is not compatible with the thermal specifications of the package used. In this situation either the charging current must be reduced (increasing the charging time) or the STBC21 enters into thermal shutdown.

This effect can be seen even in pre-charge but is less critical because this phase generally last few minutes and the current is lower but can become longer in case the chip goes into thermal shutdown.

To allow a higher current capability during charging, the power dissipation must be reduced acting on the voltage drop between input and output. To keep this difference at a minimum value the STBC21 provides a pin to drive a controller downstream so that the input voltage depends on the battery voltage.

The input voltage waveform is shaped as reported in *Figure 12*.

Figure 12. Charging process diagram

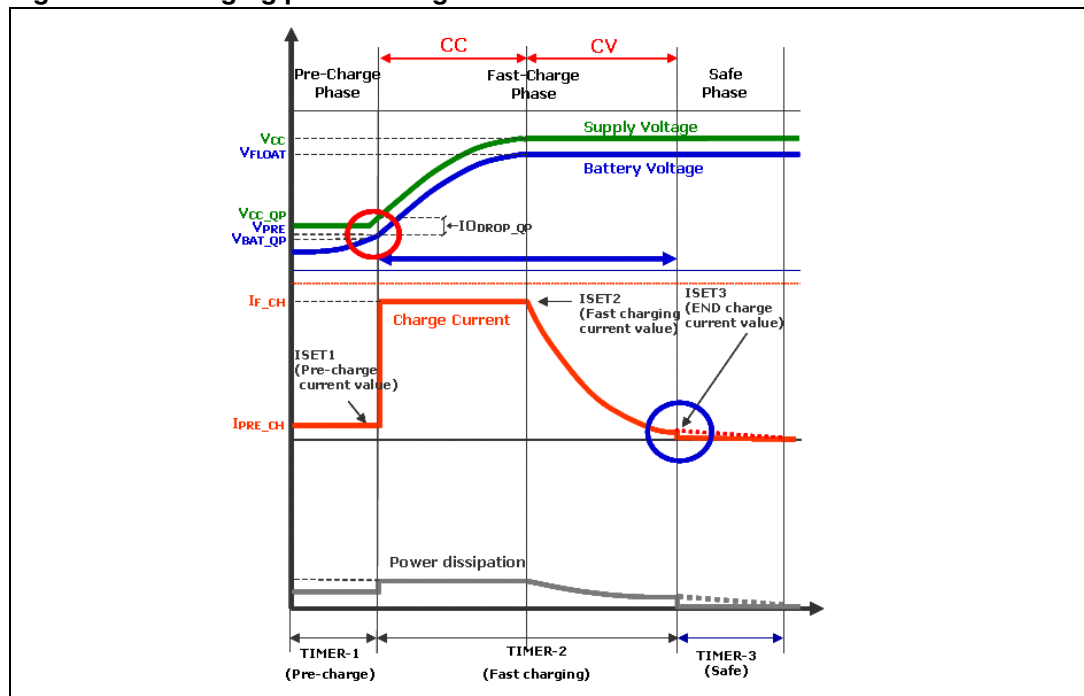

During pre-charge, until V_{BAT} reaches 2.8 V (V_{BAT_QP} threshold), the input voltage must be regulated at V_{CC_QP}. When V_{BAT} goes over 2.8 V, V_{CC} starts to increase, keeping a constant voltage difference with V_{BAT} (I_{ODROP_QP}).

5.7 Alarms

The STBC21 implements four kinds of alarms: battery alarm, charger alarm, ASD (automatic shutdown) alarm and device temperature alarm.

Battery alarm occurs when:

- TIMER-1 during pre-charge phase elapses;
- TIMER-4 during 0V-charge phase elapses;
- Overvoltage on the BAT pin occurs ($V_{BAT} > 4.23 \text{ V} \pm 20 \text{ mV}$, infringement of JEITA/PSE regulation);
- Undervoltage, during fast-charge or end of charge, on the BAT pin occurs ($V_{BAT} < 3.0 \text{ V}$);
- Undervoltage on the TEMP pin occurs ($V_{TEMP} < 0.505 \text{ V}$, battery overheating);
- Battery connection detection error occurs.

In all these cases the charge stops, the LEDs show a “Battery alarm” and a battery removal is required to reset the charger. The battery removal is spotted because the voltage on the TEMP pin rises above 2.425 V.

The battery alarm's flowchart is presented in [Figure 13](#).

Charger alarm occurs when:

- Overvoltage on the V_{CC} pin occurs ($V_{CC} > 9.0 \text{ V}$);
- Undervoltage on the V_{CC} pin occurs ($V_{CC} < 2.8 \text{ V}$, except for the power-up transition when the charger is switched on);
- Current increases over 1.1 A.

In these cases the charge is stopped, LEDs show a “charger alarm” and it's kept in this state even if the battery is removed. A V_{CC} removal is required to reset the charger.

The charger alarm's flowchart is depicted in [Figure 14](#).

Other alarms occur when:

- V_{CC} and V_{BATT} are very close (V_{CC_ASD} is lower than threshold);
- Die temperature increases over 115 °C (thermal shutdown).

In these cases the battery charge is stopped, the LEDs continue to show “charge ongoing” if the charger was in charge, and “end of charge” if the charger was in the termination phase and the timers keep on counting. Once the alarm condition is removed, the charger restarts the operations restoring the status it was in before the interruption.

During this phase, all other alarms (battery alarms and charger alarms) are active.

Figure 13. Battery alarm flowchart

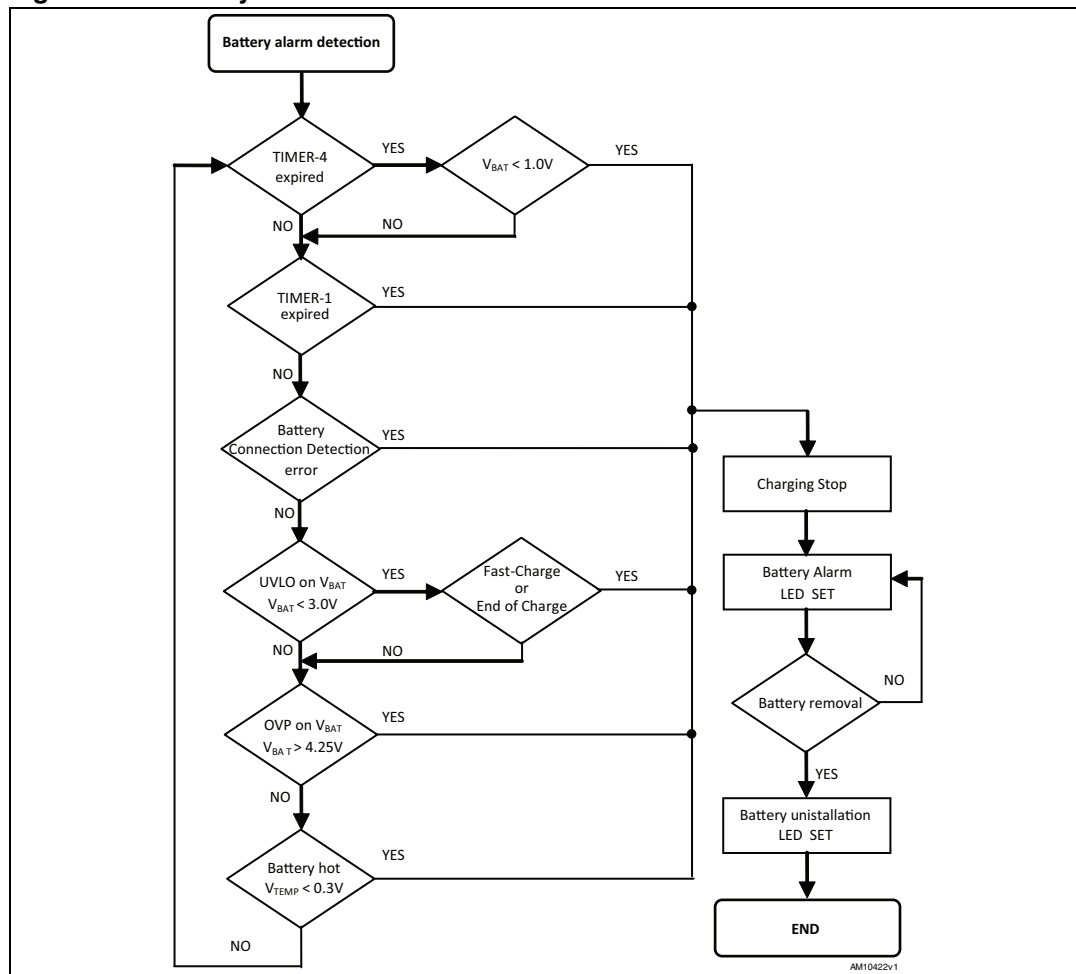
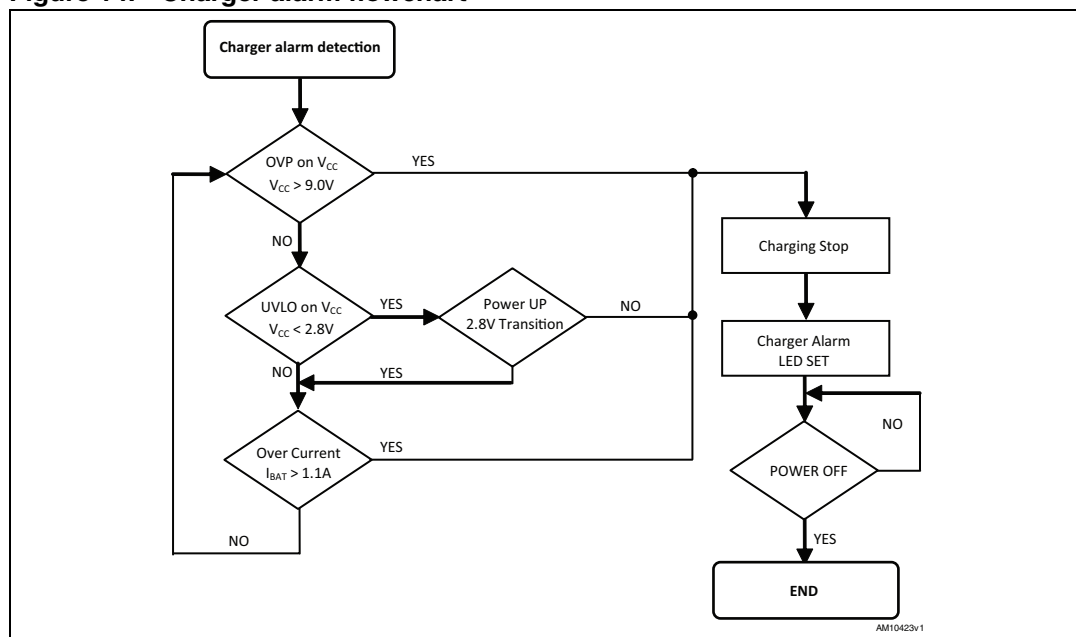
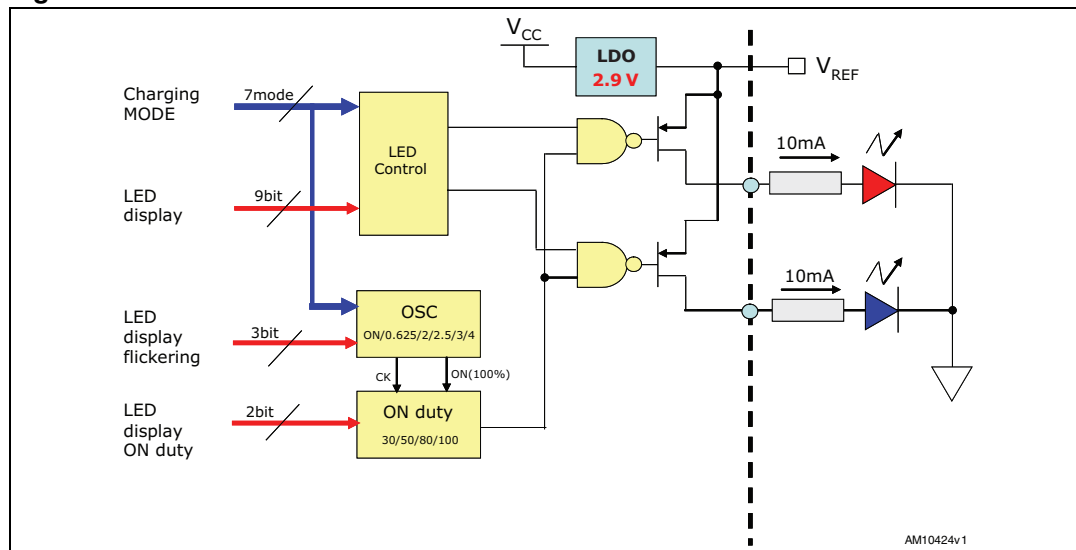

Figure 14. Charger alarm flowchart



The alarms are reported by two different LEDs driven from the high side with 10 mA current capability, as reported in [Figure 15](#). The LED current is not internally limited.

Figure 15. LEDs control circuit



See [Appendix E](#) for possible LED configurations.

As regards R_{LED} calculation, taking into account $I_{LED} = 10\text{ mA}$ and $V_{FLED} = 2\text{ V}$, we obtain:

Equation 3

$$R_{LED} = \frac{(V_{REF} - V_{FLED})}{I_{LED}} = \frac{(2.9 - 2)}{0.01} = 90\ \Omega$$

5.8 Reversed battery polarity protection

The STBC21 includes a reversed battery polarity protection to prevent damage due to an incorrect insertion of the battery in the cradle.

If the battery is able to supply 2 mA, charge doesn't start and no alarm is set.

If the battery is protected against overvoltage, undervoltage, etc. and it is in protection mode (represented as an open circuit) it is not able to supply 2 mA. In this condition, the battery connection detection alarm is set. Even in this case the charge does not start.

If the battery is not protected against overvoltage, undervoltage, etc. and battery voltage is below 1.0 V, battery connection detection is unable to start. In this case, for a time corresponding to TIMER-4 (16 sec), the battery is discharged with a pre-charge current. But when TIMER-4 elapses the battery alarm is flagged and the discharge is stopped.

5.9 Temperature protection

The STBC21 has a further protection when the dye temperature reaches 115 °C. In this condition the charge is stopped and restarts after the temperature decreases to 95 °C. During this “idle” state, LEDs continue to show “charge ongoing” if the charger was in charge, “end of charge” if the charger was in termination phase and the timers keep on

counting. Once the charger exits “idle” state (temperature decrease to 95 °C), it restarts the operations restoring the status it was in before the interruption.

The flowchart in *Figure 16* shows junction shutdown temperature detection.

Figure 16. Junction shutdown temperature detection

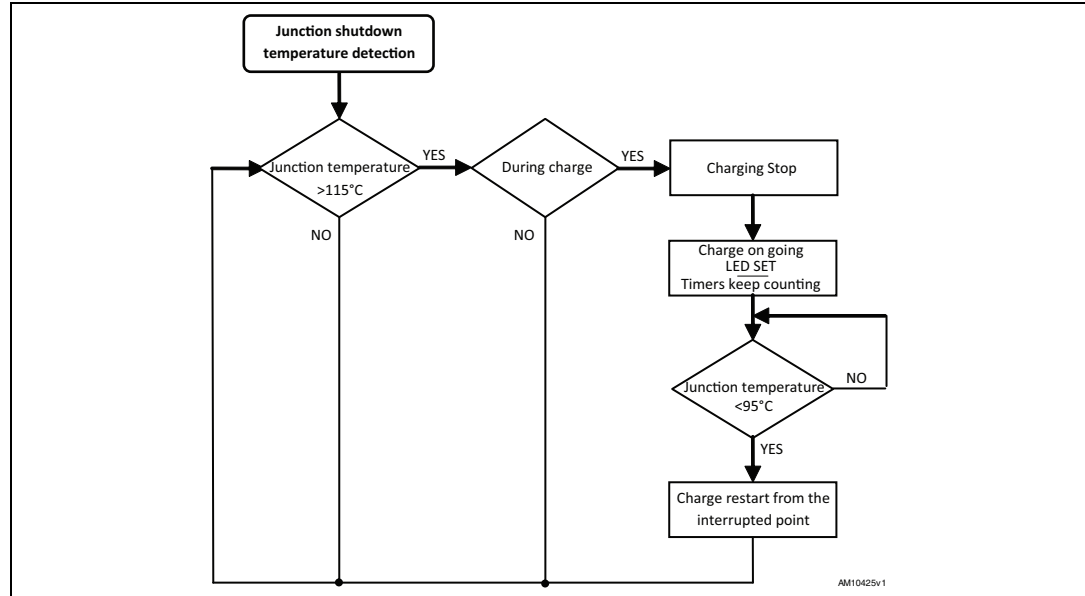

5.10 I²C data transfer

A standard I²C interface, mapped in pins RES1 (SCL) and RES2 (SDA), is used to read/write the non-volatile memory integrated into the chip. Both read and write operations can be always done based on registers or in one operation starting from a given address till the bottom of the memory.

Table 8. Write single register

S	SLAVE ADDRESS	R/W	A	REGISTER ADDRESS	A	DATA	A/An	P
	Master			Slave (STBC21)				

S = START condition (from Master to STBC21)

SLAVE ADDRESS= 6BH

R/W = '0' Write / '1' Read

A = Acknowledge (SDA low from STBC21)

REGISTER ADDRESS = From 00H to 17H (8 bits from MSB to LSB)

DATA = 8 bits data register (from MSB to LSB)

An = Acknowledge/Not Acknowledge (SDA left high from STBC21)

P = STOP condition (from Master to STBC21)

Example: Write into Reg 01H (Customer Register) in order to set the pre-charge current (ISET1) to 90 mA and end-charge current (ISET3) to 100 mA.

S	6BH	0	A	00000001	A	xx011001	A/An	P
---	-----	---	---	----------	---	----------	------	---

Table 9. Read single register

S	SLAVE ADDRESS	R/W	A	REGISTER ADDRESS	A	SEND DATA	A/An	P
Master		Slave (STBC21)						

S = START condition (from Master to STBC21)

SLAVE ADDRESS= 6BH

R/W = '0' Write / '1' Read

A = Acknowledge (SDA low from STBC21)

REGISTER ADDRESS = From 00H to 17H (8 bits from MSB to LSB)

SEND DATA = 8 bits data coming from internal addressed Register of STBC21 (from MSB to LSB)

A/An = Acknowledge/Not Acknowledge (SDA left high from Master)

P = STOP condition (from Master to STBC21)

Example: Read data from Reg 12H (charger status register) in order to know the status of the charger.

S	6BH	1	A	00010010	A	xxxxxxxx	A/An	P
---	-----	---	---	----------	---	----------	------	---

The I²C interface also performs sequential write and sequential read in order to write/read all the STBC21 registers in a single step. An internal pointer starts from the first addressed register and then returns to the first internal address (00H) when it has achieved the last internal address (17H).

5.10.1 Sequential registers write:

S	SLAVE ADDRESS	R/W (0)	A	REGISTER ADDRESS	A	DATA (Reg _x)	A	DATA (Reg _{x+1})..	A/An	P
Master		Slave (STBC21)								

S = START condition (from Master to STBC21)

SLAVE ADDRESS= 6BH

R/W = '0' Write / '1' Read

A = Acknowledge (SDA low from STBC21)

REGIST. ADDR. = First Register address (8 bits from 00H to 17H and from MSB to LSB)

DATA (Reg_x) = 8 bits data of the first addressed register (from MSB to LSB)

DATA (Reg_{x+1}) = 8 bits data of the next addressed register (from MSB to LSB)

A/An = Acknowledge/Not Acknowledge (SDA left high from STBC21)

P = STOP condition (from Master to STBC21)

5.10.2 Sequential registers read:

S	SLAVE ADDRESS	R/W (1)	A	REGISTER ADDRESS	A	SEND DATA (Reg _x)	A	SEND DATA (Reg _{x+1})...	A/An	P
	Master			Slave (STBC21)						

S = START condition (from Master to STBC21)

SLAVE ADDR. = 6BH

R/W = '0' Write / '1' Read

A = Acknowledge (SDA low from STBC21)

REG. ADDR. = First Register address (8 bits from 00H to 17H and from MSB to LSB)

SEND DATA (Reg_x)

= 8 bits of data coming from the first addressed register of STBC21 (from MSB to LSB)

SEND DATA

(Reg_{x+1}) = 8 bits of data coming from the next addressed register of STBC21 (from MSB to LSB)

A/An = Acknowledge/Not Acknowledge (SDA left high from Master)

P = STOP condition (from Master to STBC21)

6 ESD requirements

HBM \pm 2 kV, CDM \pm 500 V

ESD sensitivity of the electrical components must be tested using the following standards for each required model:

Charged device model (CDM)

- JESD22-C101-C
- ESD-STM5.3.1-1999

Human body model (HBM)

- JESD22-A114-B
- IEC6134-3-1:2002
- ESD-STM5.1-2001
- MIL-STD-883E 3015.7.

Appendix A Register configuration and access mode description

Table 10. Configuration registers map

REG/BIT	B7	B6	B5	B4	B3	B2	B1	B0
00H	AMR	TIMER-3			TIMER-2			
01H	Reserved	Reserved	ISET3				ISET1	
02H	CV-4		CV-3		CV-2		CV-1	
03H	Th				Th-h			
04H	Reserved			Hys	TI			
05H	LF45		LD7	LD45		LD3		LD2
06H	Reserved		LD6			LF267	DUTY mode	
07H	Reserved				CV4-Iset2	CV3-Iset2	CV2-Iset2	CV1-Iset2

Table 11. Control registers map

REG/BIT	B7	B6	B5	B4	B3	B2	B1	B0
10H	NVM Busy	NVM check	NVM command					
11H	VCC_uvlo	VCC_ovp	IBAT_ocr	Batt_ovp	Batt_uvlo	Batt_hot	Batt_detect_KO	Batt_no_conn
12H	ASD_Mode	Thermal protection	Batt temp alarm	Batt temp alarm	Batt_temp_soc	Timer2 expired	Timer1 expired	OV_Chrg_alarm
13H	Customer_en	CE	Reserved	Reserved	SW_chrg_alarm	SW_chrg_status		
14H	Batt_temp_range			Reserved	Iset2_half	Vfloat_05	Vfloat_10	Vfloat_20

The STBC21 has two different access modes to the internal registers: user mode and customer mode.

User mode

At power-on the STBC21 enters user mode. Only Reg11H and Reg12H are fully accessible in read-mode while Reg13H is accessible in limited write-mode (only 'customer_mode' and 'CE' bits can be written) and fully accessible in read-mode.

Customer mode

The STBC21 enters customer mode when bit7, in Reg13H, is set to '1'. In this mode the configuration of the internal system registers is:

- Reg00H to Reg07H are accessible in read/write mode;
- Reg10H has limited write access (NVM interface commands);
- Reg11H and Reg12H are accessible only in read mode;
- Reg13H has limited write access (commands bits only);
- Reg14H is accessible only in read mode.

Appendix B Charging parameters

Table 12. Timer registers summary

Timer name	Charging phase	Setting range	Min. unit	Accuracy	Step	Bit	Total
TIMER-1	Pre-charge	60 min.	FIX	±10% @ 25°C ± 15% in temp	-	-	7
TIMER-2	Fast-charge	150 min. to 510 min.	30 min.		12	4	
TIMER-3	End of charge	0 min. to 60 min. ⁽¹⁾	10 min.		7	3	
TIMER-4	0V-charge	16 sec	FIX		-	-	

1. 0 min. means timer disabled.

Table 13. Timer-2 description

TIMER-2 Reg 00H					
		Bit3	Bit2	Bit1	Bit0
150	min.	0	0	0	0
180	min.	0	0	0	1
210	min.	0	0	1	0
240	min.	0	0	1	1
270	min.	0	1	0	0
300	min.	0	1	0	1
330	min.	0	1	1	0
360	min.	0	1	1	1
390	min.	1	0	0	0
420	min.	1	0	0	1
450	min.	1	0	1	0
480	min.	1	0	1	1
510	min.	1	1	0	0

Table 14. Timer-3 description

TIMER-3 Reg 00H				
		Bit6	Bit5	Bit4
0	min.	0	0	0
10	min.	0	0	1
20	min.	0	1	0
30	min.	0	1	1
40	min.	1	0	0
50	min.	1	0	1
60	min.	1	1	0
-		1	1	1

Table 15. Charging current registers

Name	Charging phase	Setting range	Min. unit	Accuracy	Step	Bit	Total
ISET1	Pre-charge/OV-charge current value	60 mA / 90 mA / 120 mA	30 mA	± 20%	3	2	6
ISET2	Fast-charge current value	100 mA to 1100 mA ⁽¹⁾	-	± 7% @ 800 mA	Setting with external resistor		
ISET3	End of charge current value	40 mA to 190 mA ⁽¹⁾	10 mA	± 20%	16	4	

1. End of charge current is always less than fast-charge current.

Table 16. SET1 register description

ISET1 Reg 01H			
		Bit1	Bit0
60	mA	0	0
90	mA	0	1
120	mA	1	0

Table 17. ISET3 register description

ISET3 Reg 01H					
		Bit5	Bit4	Bit3	Bit2
40	mA	0	0	0	0
50	mA	0	0	0	1
60	mA	0	0	1	0
70	mA	0	0	1	1
80	mA	0	1	0	0
90	mA	0	1	0	1
100	mA	0	1	1	0
110	mA	0	1	1	1
120	mA	1	0	0	0
130	mA	1	0	0	1
140	mA	1	0	1	0
150	mA	1	0	1	1
160	mA	1	1	0	0
170	mA	1	1	0	1
180	mA	1	1	1	0
190	mA	1	1	1	1

Table 18. Constant voltage register

Name	Temperature range	Setting range	Accuracy	Step	Bit	Total
CV-1	T_{LO} to T_L -2 °C - 10 °C	4.10 V / 4.20 V / 4.05 V	±0.03 V	3	2	8
CV-2	T_L to T_H 10 °C - 45 °C	4.10 V / 4.20 V / 4.05 V		3	2	
CV-3	T_H to T_{HH} 45 °C - 50 °C	4.10 V / 4.20 V / 4.05 V		3	2	
CV-4	T_{HH} to T_{HO} 50 °C - 60 °C	4.10 V / 4.20 V / 4.05 V		3	2	

Table 19. CV1 bit description

CV1 Reg 02H			
		Bit1	Bit0
4.05	V	0	0
4.10	V	0	1
4.20	V	1	0
-		1	1

Table 20. CV2 bit description

CV2 Reg 02H			
		Bit3	Bit2
4.05	V	0	0
4.10	V	0	1
4.20	V	1	0
-		1	1

Table 21. CV3 bit description

CV3 Reg 02H			
		Bit5	Bit4
4.05	V	0	0
4.10	V	0	1
4.20	V	1	0
-		1	1

Table 22. CV4 bit description

CV4 Reg 02H			
		Bit7	Bit6
4.05	V	0	0
4.10	V	0	1
4.20	V	1	0
-		1	1

Table 23. Halving register

Name	Notes	Bit	Total
ISET CV-1	$I_{set2} \times 50\%$ in CV-1	1	4
ISET CV-2	$I_{set2} \times 50\%$ in CV-2	1	
ISET CV-3	$I_{set2} \times 50\%$ in CV-3	1	
ISET CV-4	$I_{set2} \times 50\%$ in CV-4	1	

Table 24. ISET2 (CV1) bit description

CV1-Iset2 Reg 07H	
	Bit0
ISET2 x 50% ON	1
ISET2 x 50% OFF	0

Table 25. ISET2 (CV2) bit description

CV2-Iset2 Reg 07H	
	Bit1
ISET2 x 50% ON	1
ISET2 x 50% OFF	0

Table 26. ISET2 (CV3) bit description

CV3-Iset2 Reg 07H	
	Bit2
ISET2 x 50% ON	1
ISET2 x 50% OFF	0

Table 27. ISET2 (CV4) bit description

CV4-Iset2 Reg 07H	
	Bit3
ISET2 x 50% ON	1
ISET2 x 50% OFF	0

Appendix C Charging control

Table 28. Charging control

Control	Notes	Bit	Total
Auto-recharge	Default is enabled	1	1

Table 29. Auto recharge bit description

AMR Reg 00H	
	Bit7
Automatic recharge ON	1
Automatic recharge OFF	0

Appendix D Temperature thresholds

Table 30. Temperature thresholds

Name	Temp thresholds	Setting range	Minimum unit	Accuracy	Step	Bit	Total	FTP/OTP
Battery temperature detection	T _{HO} 60 °C	0.75 V	FIX	±1% on voltage Thresholds	-	-	12	1 Time
	T _{HH} 50 °C	0.79 V -1.002 V	0.014 V		16	4		
	T _H 45 °C	0.89 V -1.10 V	0.014 V		16	4		
	T _L 10 °C	1.74 V -1.95 V	0.014 V		16	4		
	T _{LO} - 2 °C	2.128 V	FIX		-	-		
Hysteresis range	T _{HH} , T _H , T _L	2 °C - 5 °C	3 °C	2 °C = 28 mV 5 °C = 70 mV	1	1		

Table 31. Th-h reg

Th-h Reg 03H					
		Bit3	Bit2	Bit1	Bit0
0.792	V	0	0	0	0
0.806	V	0	0	0	1
0.820	V	0	0	1	0
0.834	V	0	0	1	1
0.848	V	0	1	0	0
0.862	V	0	1	0	1
0.876	V	0	1	1	0
0.890	V	0	1	1	1
0.904	V	1	0	0	0
0.918	V	1	0	0	1
0.932	V	1	0	1	0
0.946	V	1	0	1	1
0.960	V	1	1	0	0
0.974	V	1	1	0	1
0.988	V	1	1	1	0
1.002	V	1	1	1	1

Table 32. Th reg

Th Reg 03H					
		Bit7	Bit6	Bit5	Bit4
0.890	V	0	0	0	0
0.904	V	0	0	0	1
0.918	V	0	0	1	0
0.932	V	0	0	1	1
0.946	V	0	1	0	0
0.960	V	0	1	0	1
0.974	V	0	1	1	0
0.988	V	0	1	1	1
1.002	V	1	0	0	0
1.016	V	1	0	0	1
1.030	V	1	0	1	0
1.044	V	1	0	1	1
1.058	V	1	1	0	0
1.072	V	1	1	0	1
1.086	V	1	1	1	0
1.100	V	1	1	1	1

Table 33. TI reg

TI Reg 04H					
		Bit3	Bit2	Bit1	Bit0
1.740	V	0	0	0	0
1.754	V	0	0	0	1
1.768	V	0	0	1	0
1.782	V	0	0	1	1
1.796	V	0	1	0	0
1.810	V	0	1	0	1
1.824	V	0	1	1	0
1.838	V	0	1	1	1
1.852	V	1	0	0	0
1.866	V	1	0	0	1
1.880	V	1	0	1	0
1.894	V	1	0	1	1
1.908	V	1	1	0	0
1.922	V	1	1	0	1
1.936	V	1	1	1	0
1.950	V	1	1	1	1

Table 34. Hys reg

Hys Reg 04H		
		Bit4
2	°C	0
5	°C	1

Appendix E LED configurations diversified for customer (each customer one pattern)

Table 35. LED configurations

Pattern	Battery charger mode	LED-flickering timing	LED-Red	LED-Green
1	1.Battery uninstallation		Off	Off
	2.Charging control		On	Off
	3.Charging completion		Off	On
	4.Charger alarm	f = 3 Hz	Flickering	Off
	5.Battery alarm	f = 3 Hz	Flickering	Off
	6.Temperature waiting control		Off	Off
2	1.Battery uninstallation		Off	Off
	2.Charging control		On	Off
	3.Charging completion		Off	On
	4.Charger alarm	f = 2.5 Hz	Flickering	Off
	5.Battery alarm	f = 2.5 Hz	Flickering	Off
	6.Temperature waiting control		On	Off
3	1.Battery uninstallation		Off	Off
	2.Charging control		On	Off
	3.Charging completion		Off	On
	4.Charger alarm	f = 2.5 Hz	Flickering	Off
	5.Battery alarm	f = 2.5 Hz	Flickering	Off
	6.Temperature waiting control	f = 0.625 Hz	Flickering	Off
4	1.Battery uninstallation		Off	Off
	2.Charging control	f = 0.625 Hz	Flickering	Flickering
	3.Charging completion		On	On
	4.Charger alarm	f = 2.5 Hz	Flickering	Flickering
	5.Battery alarm	f = 2.5 Hz	Flickering	Flickering
	6.Temperature waiting control/charging start	f = 0.625 Hz	Flickering	Flickering
	7.Temperature waiting control/during charging		On	On
5	1.Battery uninstallation		Off	Off
	2.Charging control		On	Off
	3.Charging completion		Off	On
	4.Charger alarm		Off	Off
	5.Battery alarm		Off	Off
	6.Temperature waiting control		On	Off

Table 35. LED configurations (continued)

Pattern	Battery charger mode	LED-Flickering timing	LED-Red	LED-Green
6	1.Battery uninstallation		Off	Off
	2.Charging control		On	Off
	3.Charging completion		Off	On
	4.Charger alarm		Off	Off
	5.Battery alarm		Off	Off
	6.Temperature waiting control		Off	Off
7	1.Battery uninstallation		Off	Off
	2.Charging control		On	Off
	3.Charging completion		Off	On
	4.Charger alarm		Off	Off
	5.Battery alarm		Off	Off
	6.Temperature waiting control	f = 0.625 Hz	Flickering	Off
8	1.Battery uninstallation		Off	Off
	2.Charging control	f = 2 Hz	Flickering	Flickering
	3.Charging completion	f = 4 Hz	Off	Flickering
	4.Charger alarm	f = 2 Hz	Flickering	Off
	5.Battery alarm	f = 2 Hz	Flickering	Off
	6.Temperature waiting control	f = 2 Hz	Flickering	Flickering

Appendix F LED display modes

As a consequence of the configuration reported in [Appendix E](#) there are 7 possible modes:

Table 36. LED display modes

Function	Condition	LED modes	Mode	Bit	Total
LED display	1.Battery uninstillation	OFF	1	0	9
	2.Charging control	1.ON / 2.FL	2	1	
	3.Charging completion	1.OFF /2.ON /3.OFF	3	2	
	4.Charger alarm	1.FL /2.FL /3.OFF	3	2	
	5.Battery alarm				
	6.Temperature waiting control / after charging starts	1.OFF/ 2.ON/3.OFF/ 4.FL/5.FL	5	3	
	7.Temperature waiting control / during charging	1.ON/ 2. Same iLumination MODE 6 6.Temperature waiting control / (after charging starts)	2	1	

Table 37. LED frequency register

Function	Parameter	Range	Minimum	Accuracy	# Step	# Bit	Total
Flickering frequency	1.Battery uninstillation	FIXED			1	0	3
	2.Charging control	0.625 Hz, 2 Hz	-	±10%	2	1	
	3.Charging completion	4 Hz	-	±10%	1	0	
	4.Charger alarm	2 Hz, 2.5 Hz, 3 Hz, 4 Hz	-	±10%	4	2	
	5.Battery alarm	2 Hz, 2.5 Hz, 3 Hz, 4 Hz	-	±10%	4	(1)	
	6.Temperature waiting control / after charging starts	0.625 Hz, 2 Hz	-	±10%	2	(2)	
	7.Temperature waiting control / during charging	0.625 Hz, 2 Hz	-	±10%	2	(2)	

1. Same as mode 4.
2. Same as mode 2.

Table 38. LED duty cycle register

Function	Condition	Range	Minimum	Accuracy	# Step	# Bits	Total
Flickering duty cycle	1. Battery uninstillation	FIXED			1	0	2
	2. Charging control	30%, 50%, 80%	30%	± 2%			
	3. Charging completion						
	4. Charger alarm						
	5. Battery alarm						
	6. Temperature waiting control / after charging starts						
	7. Temperature waiting control / during charging						

LED display configurations

CHARGE RUNNING Reg 05H	
	Bit0
ON-OFF	0
FL-FL	1

CHARGE COMPLETE Reg 05H		
	Bit2	Bit1
OFF-ON	0	0
ON-ON	0	1
OFF-FL	1	0
Reserved	1	1

BATTERY/CHARGER ALARM Reg 05H		
	Bit4	Bit3
FL-OFF	0	0
FL-FL	0	1
OFF-OFF	1	0
Reserved	1	1

BATTERY TEMP. CONTROL (charge start mode) Reg 06H			
	Bit5	Bit4	Bit3
OFF-OFF	0	0	0
ON-OFF	0	0	1
OFF-FL	0	1	0
FL-FL	0	1	1
FL-FL	1	0	0
Reserved	1	0	1
Reserved	1	1	0
Reserved	1	1	1

BATTERY TEMP. CONTROL (charge running mode) Reg 05H	
	Bit5
ON-ON	0
Same as in "charge start mode"	1

LED display flickering frequency

BATTERY/CHARGER ALARM Reg 05H		
	Bit7	Bit6
2 Hz	0	0
2.5 Hz	0	1
3.0 Hz	1	0
4.0 Hz	1	1

CHARGE RUNNING AND TEMPERATURE CONTROL Reg 06H	
	Bit2
0.625 Hz	0
2.0 Hz	1

DUTY CYCLE MODES Reg 06H		
	Bit1	Bit0
30%	0	0
50%	0	1
80%	1	0
Reserved	1	1

Appendix G NVM commands register

Table 39. Address: 10H, Reset state: 00000000

Bit	Name	Read/Write	Function
B7(MSB)	NVM busy	Read	1: NVM activity; 0: NVM free
B6	NVM check flag	Read	1: NVM data check failed; 0: NVM data check OK
B5	NVM command	Read/Write	NVM commands (see Table 40)
B4		Read/Write	
B3		Read/Write	
B2		Read/Write	
B1		Read/Write	
B0(LSB)		Read/Write	

Table 40. NVM commands

100 000	U ⁽¹⁾	Erase partial memory
001 000	U	Write partial memory array
011 000	U	Write partial complementary memory array
010 000 110 000	U	Read partial memory

1. NVM commands classified as 'U' are User allowed [permitted if customer_en=1 (Reg13H, B7)].

Appendix H Charger, battery and alarm status registers

Table 41. Address: 11H, Reset state: 00000000

Bit	Name	Read/Write	Function
B7(MSB)	VCC_uvlo	Read	1: VCC undervoltage protection, valid only after initialization. Cleared at reset or sw_alarms_clr=Reg13H(5).
B6	VCC_ovp	Read	1: VCC over protection. Cleared at reset or sw_alarms_clr.
B5	IBAT_ocp	Read	1: IBAT over protection. Cleared at reset or sw_alarms_clr.
B4	Batt_ovp	Read	1: Battery overvoltage protection always active. Cleared at battery disconnection or sw_alarms_clr, disabled by Reg19H(6).
B3	Batt_uvlo	Read	1: Battery undervoltage protection valid only in fast-charge. Cleared at battery disconnection or sw_alarms_clr.
B2	Batt_hot	Read	1: Battery temperature too high. Cleared at battery disconnection or sw_alarms_clr.
B1	Batt_detect_KO	Read	1: Battery detection failed. Cleared at battery disconnection or sw_alarms_clr.
B0(LSB)	Batt_no_conn	Read	1: Battery disconnected

Table 42. Address: 12H, Reset state: 00000000

Bit	Name	Read/Write	Function
B7(MSB)	ASD_mode	Read	1: Automatic shutdown mode.
B6	Thermal protection	Read	1: Chip temperature over 115 °C.
B5	Batt_temp_alarm (T>60 °C)	Read	1: Battery temp. is out of range during charge. At the first occurrence it can be cleared if the battery temp. returns again in a good range; after the first one, a battery disconnection or sw_alarms_clr is needed.
B4	Batt_temp_alarm (T>60 °C or T<0 °C)	Read	1: Battery temp. is out of range during charge. Cleared if battery temp. returns in a good range or at battery disconnection or sw_alarm_clr.
B3	Batt_temp_soc (at batt. insertion)	Read	1: Battery temp. is out of range at start of charge (battery connection). Cleared at battery disconnection or sw_alarms_clr or when temperature returns in good range.
B2	Timer2_expired	Read	1: Timer2 expired. Active only during fast-charge. Cleared at battery disconnection or sw_alarms_clr.
B1	Timer1_expired	Read	1: Timer1 expired. Active only during pre-charge. Cleared at battery disconnection or sw_alarms_clr.
B0(LSB)	0 V-Chrg_alarm	Read	1: Timer4 expired and battery still under 1 V. Cleared at battery disconnection or sw_alarms_clr.

Table 43. Address: 13H, Reset state: 00000000

Bit	Name	Read/Write	Function
B7 (MSB)	customer_en	Read/Write	1: Enable customer functions; 0: Disable
B6	CE	Read/Write	0: Charger enabled (default value); 1: Charger disabled.
B5	Reserved		
B4	Reserved		
B3	SW_chrg_alarm	Read	1: Digital charger alarm during IDLE.
B2	SW_chrg_status	Read	Digital charger status (see Table 44).
B1		Read	
B0 (LSB)		Read	

Table 44. Digital charger status

000	IDLE
001	Battery detection (force)
010	Battery detection (1 st)
011	Pre-charge
100	Fast-charge
101	Safe-charge
110	Battery detection (2 nd)
111	Termination

Table 45. Address: 14H, Reset state: 00000000

Bit	Name	Read/Write	Function
B7 (MSB)	Batt_temp_range	Read	Battery temperature range (see Table 46)
B6		Read	
B5		Read	
B4	Reserved		
B3	Iset2_half	Read	1: Iset2 (fast-charge current) set to 50%
B2	Vfloat_05	Read	1: Vfloat set to 4.05 V
B1	Vfloat_10	Read	1: Vfloat set to 4.10 V
B0 (LSB)	Vfloat_20	Read	1: Vfloat set to 4.20 V

Table 46. Battery temperature range

000	No battery
001	Battery temperature > 60 °C
010	Battery temperature > 50 °C
011	Battery temperature > 45 °C
100	Battery temperature > 10 °C
101	Battery temperature > 0 °C
110	Battery temperature < 0 °C
111	Battery temperature < 0 °C

H.1 Layout guidelines

The layout of the application board for the STBC21 is very critical due to the high precision required on charging parameters which can be met only by minimizing the voltage drops across the connecting tracks and the noise in the ground plane.

For these reasons the following guidelines are strongly suggested:

1. Input and output decoupling capacitor should be placed as close as possible to the STBC21 with short trace runs to both IN, OUT.
2. All low current GND connections should be kept separate from the high current charge or discharge paths from the battery.
3. Use a single-point ground technique incorporating both the small signal ground path and the power ground path.
4. The high current charge paths into the IN pin and from the OUT pin must be sized appropriately in order to avoid voltage drops in these traces.
5. VBAT_SNS must be connected to VBAT as near as possible to the battery pin.

The layout of the board is reported below.

Figure 17. Layout board (top through view)

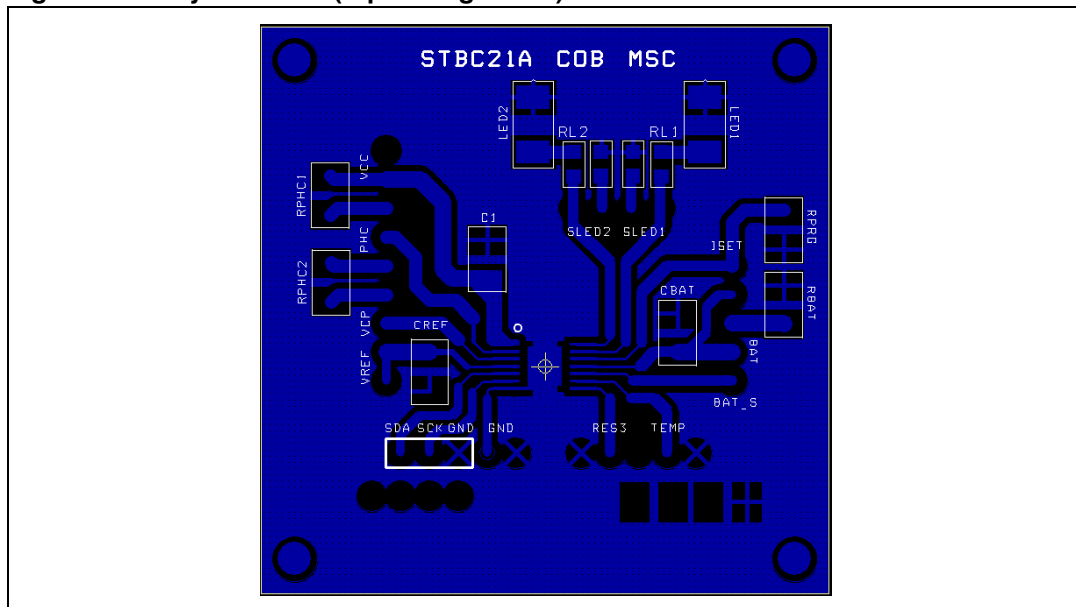
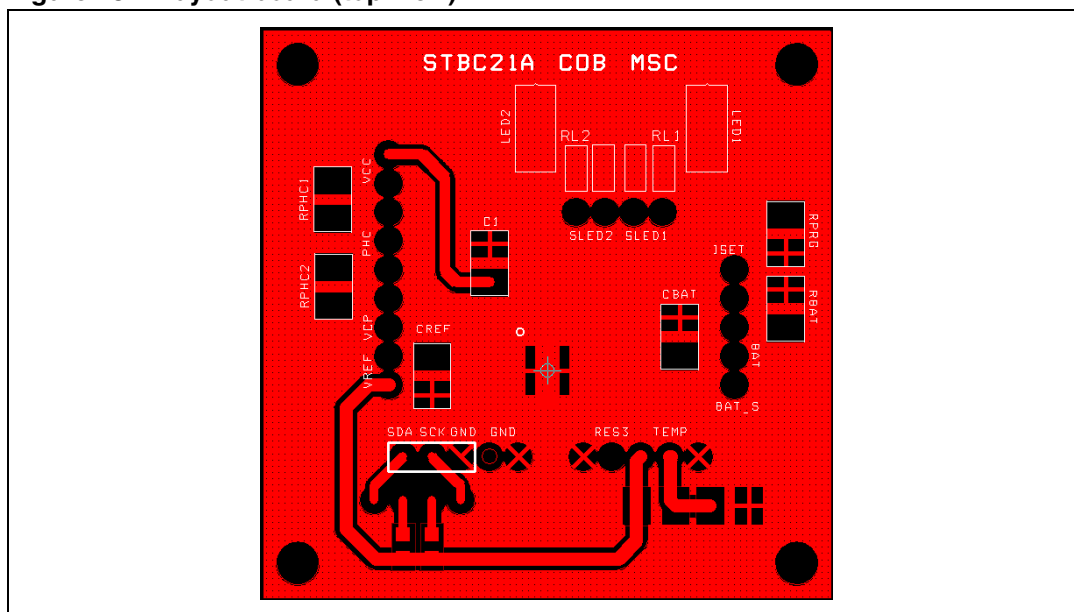

Figure 18. Layout board (top view)



7 Package mechanical data

In order to meet environmental requirements, ST offers these devices in different grades of ECOPACK® packages, depending on their level of environmental compliance. ECOPACK specifications, grade definitions and product status are available at: www.st.com. ECOPACK is an ST trademark.

Table 47. HTSSOP-14L (5 x 4.4 mm) mechanical data

Dim.	mm.		
	Min.	Typ.	Max.
A			1.20
A1			0.15
A2	0.80	1.00	1.05
b	0.19		0.30
c	0.09		0.20
D	4.90	5.00	5.10
D1	1.70		
E	6.20	6.40	6.60
E1	4.30	4.40	4.50
E2	1.50		
e		0.65	
L	0.45	0.60	0.75
L1		1.00	
k	0		8
aaa			0.10

Figure 19. Drawing dimension HTSSOP-14L (5 x 4.4 mm)

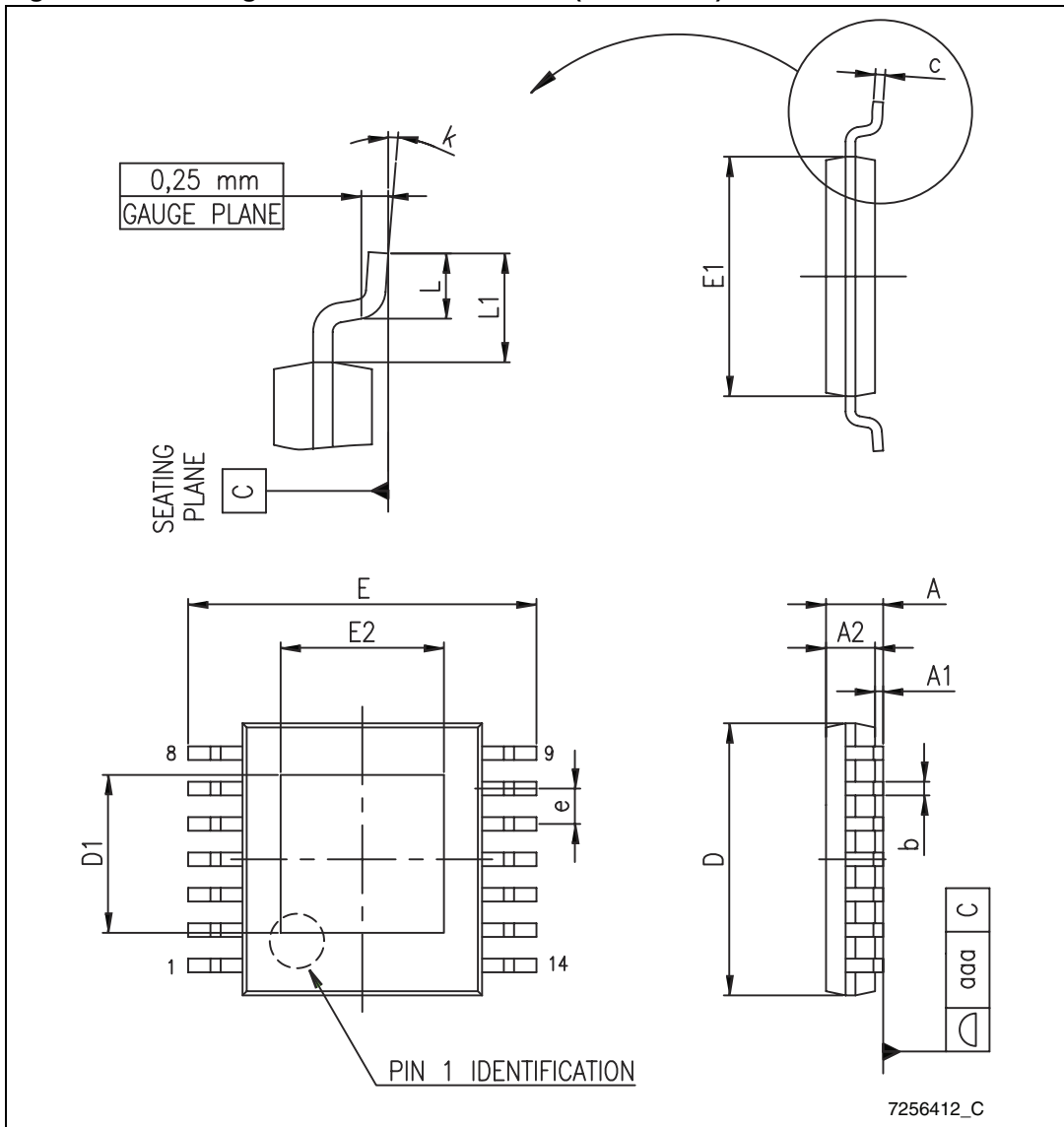

8 Revision history

Table 48. Document revision history

Date	Revision	Changes
07-Jun-2012	1	Initial release

Please Read Carefully:

Information in this document is provided solely in connection with ST products. STMicroelectronics NV and its subsidiaries ("ST") reserve the right to make changes, corrections, modifications or improvements, to this document, and the products and services described herein at any time, without notice.

All ST products are sold pursuant to ST's terms and conditions of sale.

Purchasers are solely responsible for the choice, selection and use of the ST products and services described herein, and ST assumes no liability whatsoever relating to the choice, selection or use of the ST products and services described herein.

No license, express or implied, by estoppel or otherwise, to any intellectual property rights is granted under this document. If any part of this document refers to any third party products or services it shall not be deemed a license grant by ST for the use of such third party products or services, or any intellectual property contained therein or considered as a warranty covering the use in any manner whatsoever of such third party products or services or any intellectual property contained therein.

UNLESS OTHERWISE SET FORTH IN ST'S TERMS AND CONDITIONS OF SALE ST DISCLAIMS ANY EXPRESS OR IMPLIED WARRANTY WITH RESPECT TO THE USE AND/OR SALE OF ST PRODUCTS INCLUDING WITHOUT LIMITATION IMPLIED WARRANTIES OF MERCHANTABILITY, FITNESS FOR A PARTICULAR PURPOSE (AND THEIR EQUIVALENTS UNDER THE LAWS OF ANY JURISDICTION), OR INFRINGEMENT OF ANY PATENT, COPYRIGHT OR OTHER INTELLECTUAL PROPERTY RIGHT.

UNLESS EXPRESSLY APPROVED IN WRITING BY TWO AUTHORIZED ST REPRESENTATIVES, ST PRODUCTS ARE NOT RECOMMENDED, AUTHORIZED OR WARRANTED FOR USE IN MILITARY, AIR CRAFT, SPACE, LIFE SAVING, OR LIFE SUSTAINING APPLICATIONS, NOR IN PRODUCTS OR SYSTEMS WHERE FAILURE OR MALFUNCTION MAY RESULT IN PERSONAL INJURY, DEATH, OR SEVERE PROPERTY OR ENVIRONMENTAL DAMAGE. ST PRODUCTS WHICH ARE NOT SPECIFIED AS "AUTOMOTIVE GRADE" MAY ONLY BE USED IN AUTOMOTIVE APPLICATIONS AT USER'S OWN RISK.

Resale of ST products with provisions different from the statements and/or technical features set forth in this document shall immediately void any warranty granted by ST for the ST product or service described herein and shall not create or extend in any manner whatsoever, any liability of ST.

ST and the ST logo are trademarks or registered trademarks of ST in various countries.

Information in this document supersedes and replaces all information previously supplied.

The ST logo is a registered trademark of STMicroelectronics. All other names are the property of their respective owners.

© 2012 STMicroelectronics - All rights reserved

STMicroelectronics group of companies

Australia - Belgium - Brazil - Canada - China - Czech Republic - Finland - France - Germany - Hong Kong - India - Israel - Italy - Japan - Malaysia - Malta - Morocco - Philippines - Singapore - Spain - Sweden - Switzerland - United Kingdom - United States of America

www.st.com