

## OUTLINE

The RN5RG Series are CMOS-based voltage regulator ICs with an external power transistor with high output voltage accuracy and lowest supply current. Each of these voltage regulator ICs consists of a voltage reference unit, an error amplifier and resistors.

These ICs are suitable for constructing regulators with ultra-low dropout voltage and an output current in the range of several tens mA to several hundreds mA.

Furthermore, these ICs have a chip enable function, so that the supply current on standby can be minimized.

Since the package for these ICs is SOT-23-5 (Mini-mold) package, high density mounting of the ICs on boards is possible.

## FEATURES

- Ultra-Low Supply Current .....Typ. 50 $\mu$ A
- Standby Mode.....Typ. 0.2 $\mu$ A
- Ultra-Low Dropout Voltage .....Typ. 0.1V ( $I_{OUT}=100$ mA : dependent on External Tr.)
- Low Temperature-Drift Coefficient of Output Voltage .....Typ.  $\pm 100$  ppm/ $^{\circ}$ C
- Excellent Line Regulation .....Typ. 0.1%/V
- Output Voltage .....Stepwise setting with a step of 0.1V in the range of 2.0V to 6.0V is possible (refer to Selection Guide).
- High Accuracy Output Voltage ..... $\pm 2.5\%$
- Small Package .....SOT-23-5(Mini-Mold)

## APPLICATIONS

- Power source for battery-powered equipment.
- Power source for cameras, VCRs, camcorders, hand-held audio instruments, and hand-held communication equipment.
- Power source for domestic appliances.

## BLOCK DIAGRAM

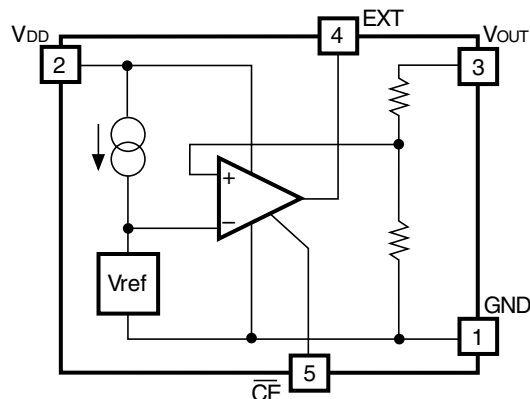

## SELECTION GUIDE

The output voltage, the version, the packing type, and the taping type for the ICs can be selected at the user's request.

The selection can be made by designating the part number as shown below :

RN5RG $\overbrace{\text{xxxx}}$  -  $\overbrace{\text{xx}}$  ← Part Number  
    ↑↑↑  ↑  
    a bc  d

Code	Contents
a	Setting Output Voltage (VOUT): Stepwise setting with a step of 0.1V in the range of 2.0V to 6.0V is possible.
b	A
c	Designation of Packing Type: A: Taping C: Antistatic bag for samples
d	Designation of Taping Type: Ex. TR, TL (refer to Taping Specifications) “TR” is prescribed as a standard.

For example, the product with Output Voltage 5.0V, Version A, and Taping Type TR is designated by Part Number RN5RG50AA-TR.

## PIN CONFIGURATION

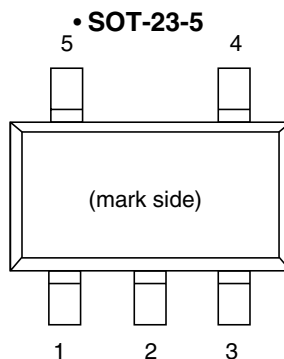

## PIN DESCRIPTION

Pin No.	Symbol	Description
1	GND	Ground Pin
2	V <sub>DD</sub>	Input Pin
3	V <sub>OUT</sub>	Output Pin
4	EXT	External Transistor Drive Pin (Nch Open Drain Output)
5	$\overline{\text{CE}}$	Chip Enable Pin

## ABSOLUTE MAXIMUM RATINGS

Symbol	Item	Rating	Unit
V <sub>IN</sub>	Input Voltage	+12	V
V <sub>CE</sub>	Input Voltage ( $\overline{\text{CE}}$ Pin)	-0.3 to V <sub>IN</sub> +0.3	V
V <sub>EXT</sub>	EXT Output Voltage	+12	V
I <sub>EXT</sub>	EXT Output Current	50	mA
P <sub>D</sub>	Power Dissipation	150	mW
T <sub>opt</sub>	Operating Temperature Range	-40 to +85	°C
T <sub>stg</sub>	Storage Temperature Range	-55 to +125	°C
T <sub>solder</sub>	Lead Temperature (Soldering)	260°C, 10s	

### ABSOLUTE MAXIMUM RATINGS

Absolute Maximum ratings are threshold limit values that must not be exceeded even for an instant under any conditions. Moreover, such values for any two items must not be reached simultaneously. Operation above these absolute maximum ratings may cause degradation or permanent damage to the device. These are stress ratings only and do not necessarily imply functional operation below these limits.

## ELECTRICAL CHARACTERISTICS

T<sub>opt</sub>=25°C

Symbol	Item	Conditions	Min.	Typ.	Max.	Unit	Note
V <sub>OUT</sub>	Output Voltage	V <sub>IN</sub> =8.0V I <sub>OUT</sub> =50mA	V <sub>OUT</sub> ×0.975		V <sub>OUT</sub> ×1.025	V	
I <sub>OUT</sub>	Output Current	V <sub>IN</sub> -V <sub>OUT</sub> =1.0V		1000		mA	Note
I <sub>EXT</sub>	EXT Current	V <sub>IN</sub> =4.0V, V <sub>EXT</sub> =2.0V	10			mA	
$\frac{\Delta V_{OUT}}{\Delta I_{OUT}}$	Load Regulation	V <sub>IN</sub> -V <sub>OUT</sub> =1.0V 1mA≤I <sub>OUT</sub> ≤100mA	-60		60	mV	
V <sub>DIF</sub>	Dropout Voltage	I <sub>OUT</sub> =100mA		100	200	mV	
I <sub>SS</sub>	Supply Current	V <sub>IN</sub> -V <sub>OUT</sub> =1.0V I <sub>OUT</sub> =0mA (at no load)		50	80	μA	
I <sub>standby</sub>	Supply Current (Standby)	V <sub>IN</sub> =8V	0.01	0.20	1.00	μA	
I <sub>EXTleak</sub>	EXT Leakage Current				0.5	μA	
$\frac{\Delta V_{OUT}}{\Delta V_{IN}}$	Line Regulation	I <sub>OUT</sub> =50mA V <sub>OUT</sub> +0.5V≤V <sub>IN</sub> ≤8V	0.0	0.1	0.3	%/V	
V <sub>IN</sub>	Input Voltage				8	V	
V <sub>EXT</sub>	EXT Output Voltage				8	V	
$\frac{\Delta V_{OUT}}{\Delta T_{opt}}$	Output Voltage Temperature Coefficient	I <sub>OUT</sub> =10mA -40°C≤T <sub>opt</sub> ≤85°C		±100		ppm/°C	
V <sub>CEH</sub>	$\overline{CE}$ Input Voltage "H"		1.5			V	
V <sub>CEL</sub>	$\overline{CE}$ Input Voltage "L"				0.25	V	
I <sub>CEH</sub>	$\overline{CE}$ Input Current "H"			0.0	0.1	μA	
I <sub>CEL</sub>	$\overline{CE}$ Input Current "L"		-5.0	-3.0	-0.1	μA	

(Note) The output current depends upon the performance of External PNP Transistor. Use External PNP Transistor of a low saturation type, with an h<sub>FE</sub> of 100 or more.

\*) With respect to Test Circuits, refer to the Typical Application.

## OPERATION

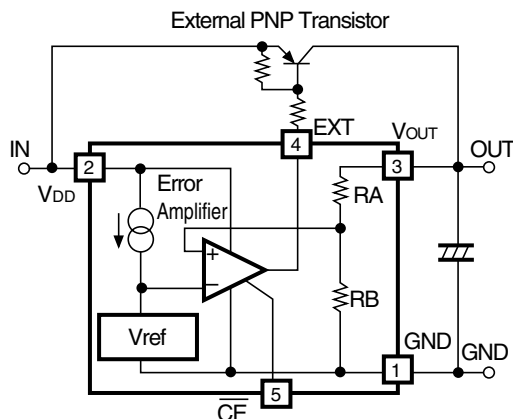

In these ICs, the output voltage  $V_{OUT}$  is detected by feed-back registers RA, RB, and the detected the output voltage is compared with a reference voltage by error Amplifier, so that the base current of an external PNP transistor is adjusted and the output voltage  $V_{OUT}$  is regulated.

## SELECTION GUIDE FOR EXTERNAL COMPONENTS

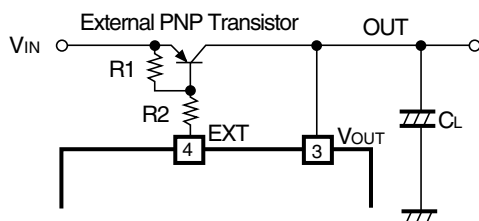

### 1.External PNP Transistor

Select an external PNP transistor from the viewpoints of output current, input voltage and power dissipation.

Generally external PNP transistor with low  $V_{CE(SAT)}$  and high  $h_{FE}$  is suitable.

### 2.Base Resistor R2

EXT Pin of these ICs is protected by a current limit circuit from the destruction caused by excess current. However, since this current limit circuit is provided for the purpose of protecting the IC, use a resistor R2 for the protection of the External Transistor, although this IC can be operated without such a resistor. It is required that the resistance of the Resistor R2 be determined with the input voltage, output voltage, output current, temperature, and the  $h_{FE}$  value taken into consideration and the dispersion of these values. Before making such a determination, check the characteristics by calculating the respective values by using the following formula :

$$\frac{V_{IN} [\text{Min.}] - 1.2(\text{V})}{R2} - \frac{0.7(\text{V})}{R1} > \frac{I_{OUT} [\text{Max.}]}{h_{FE}}$$

### 3.Phase Compensation

In these ICs, phase compensation is made for securing stable operation even when the load current is varied. For this purpose, be sure to use a capacitor  $C_L$  (tantalum type) with a capacitance of  $10\mu\text{F}$  or more and a resistor R1 with a resistance of about  $10\text{k}\Omega$  between the base and the emitter. There may be the case the loop oscillation takes place when a tantalum capacitor  $C_L$  with a large ESR is used, so select the  $C_L$  carefully including the frequency characteristics.

TEST CIRCUITS

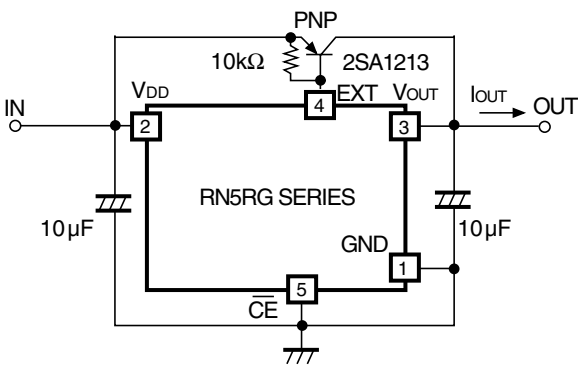

Test Circuit 1 : Typical Characteristics 1) to 4)

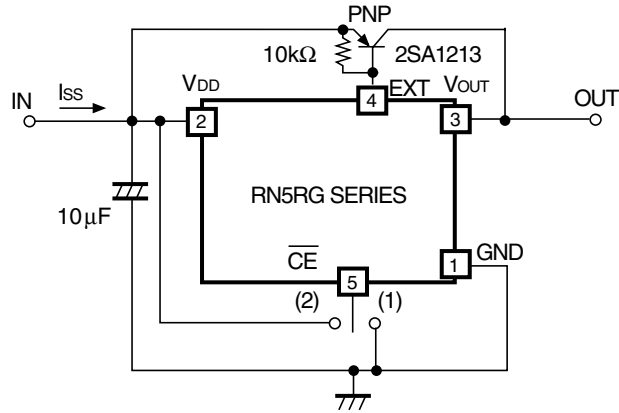

Test Circuit 2 : Typical Characteristics 5) to 7)

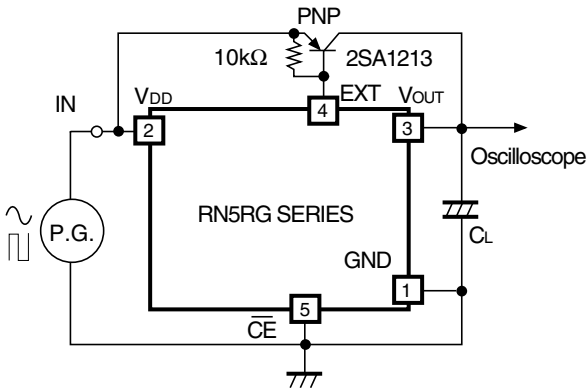

Test Circuit 3 : Typical Characteristics 8) to 10)

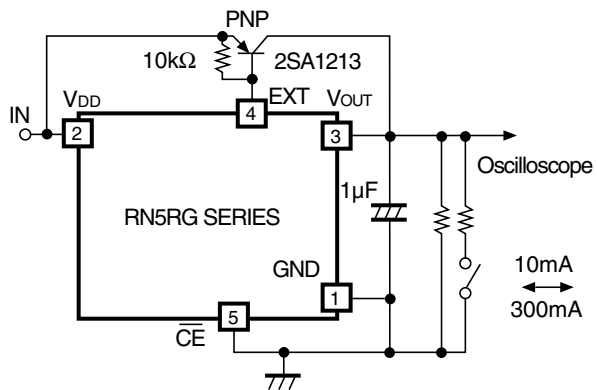

Test Circuit 4 : Typical Characteristics 11)

# TYPICAL CHARACTERISTICS

## 1) Output Voltage vs. Input Voltage

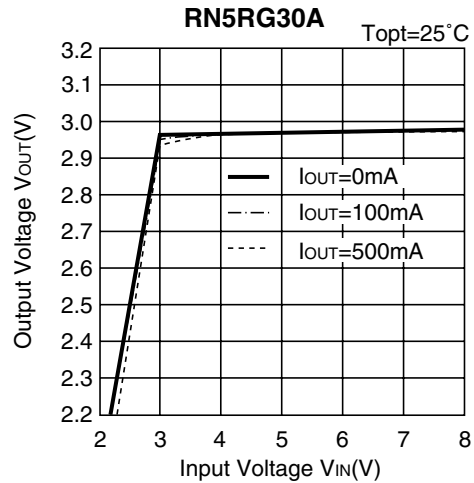
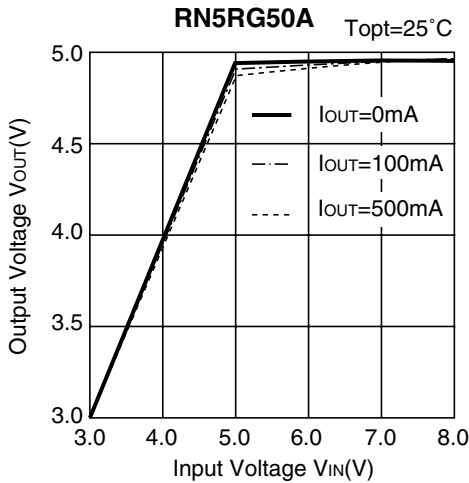

## 2) Output Voltage vs. Output Current

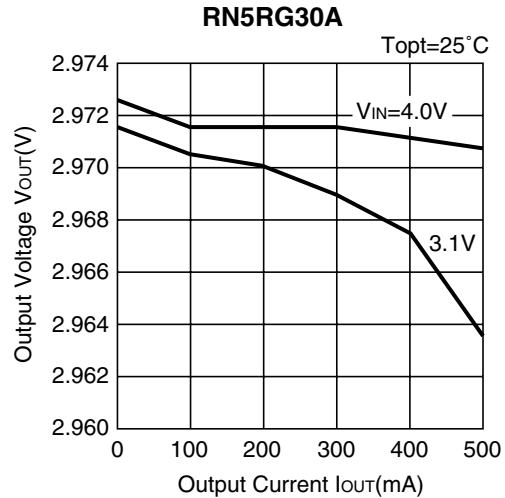
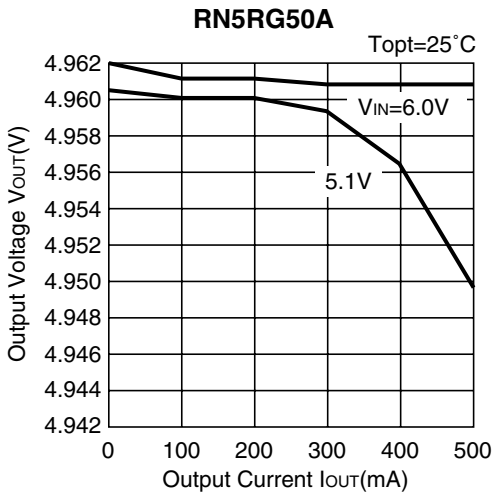

## 3) Dropout Voltage vs. Output Current

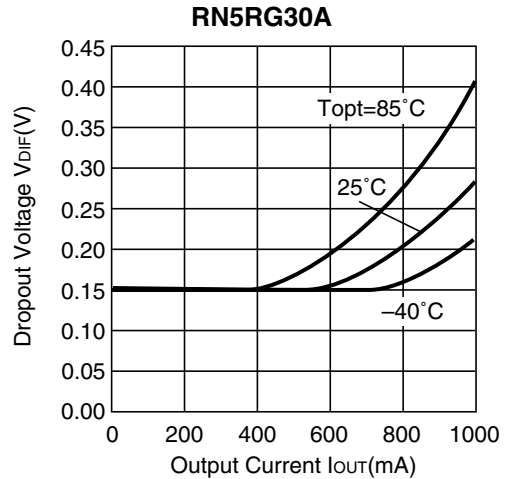
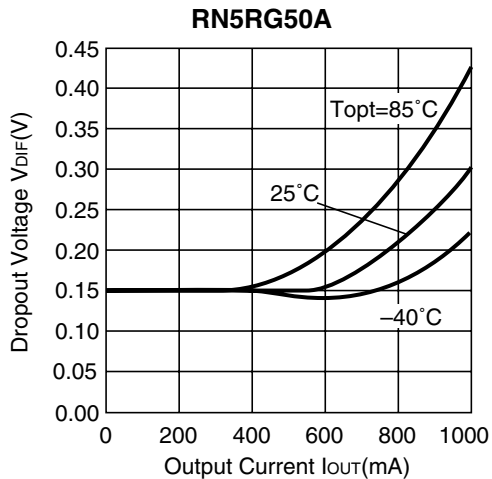

**4) Output Voltage vs. Temperature**

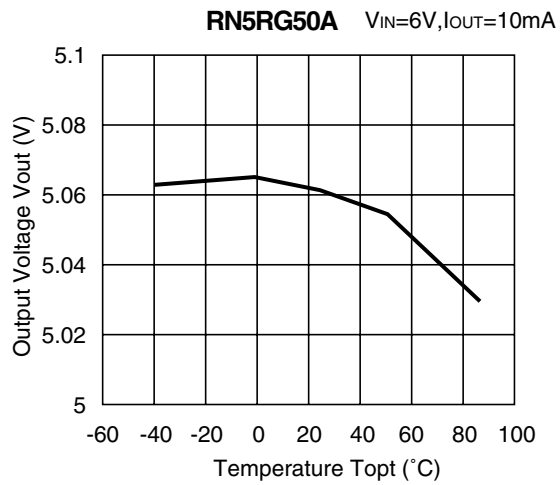
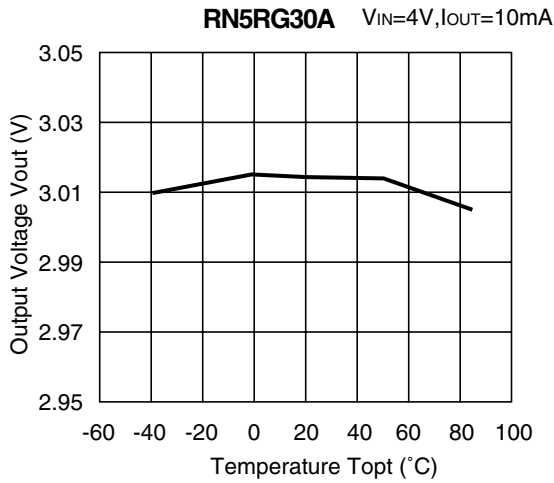

**5) Supply Current vs. Input Voltage**

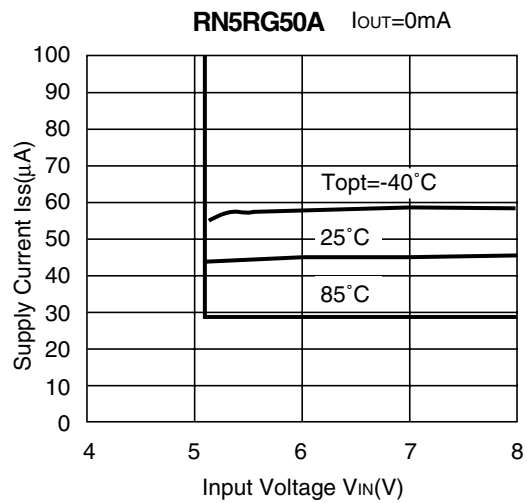
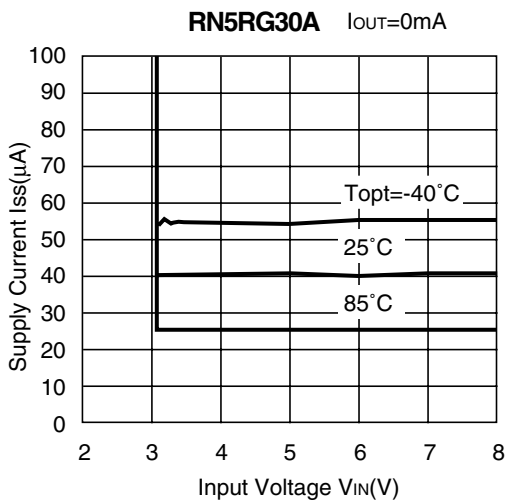

**6) Supply Current vs. Temperature**

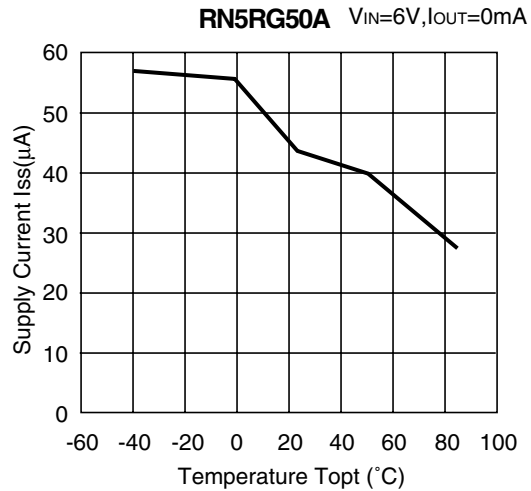
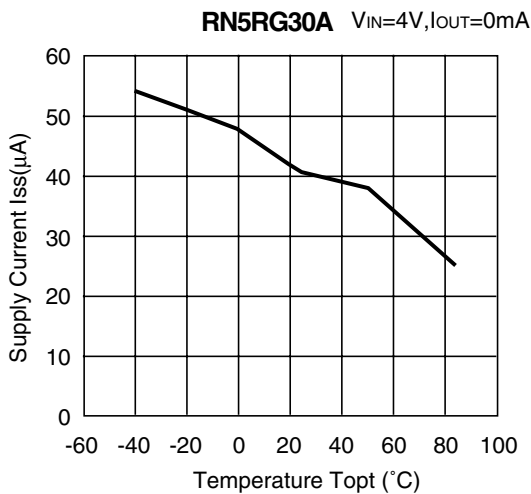



7) Standby Current vs. Input Voltage

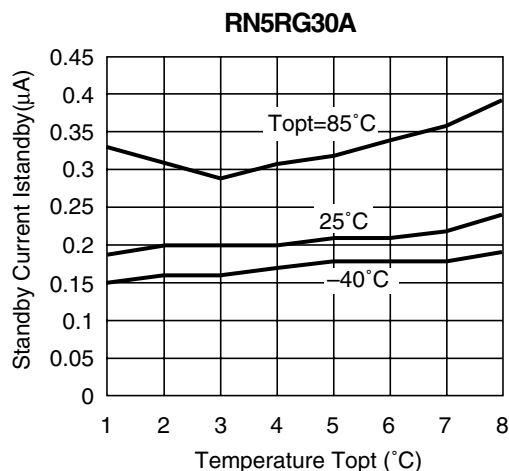
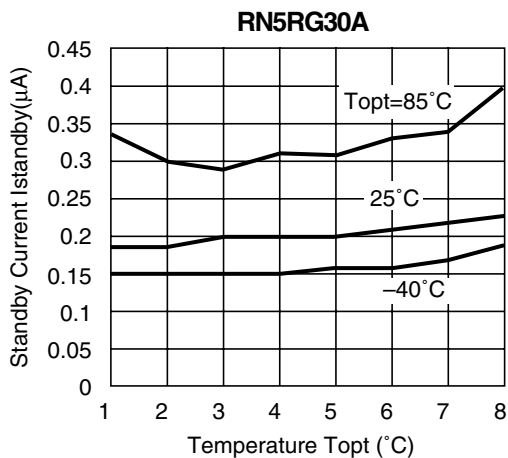

8) Ripple Rejection

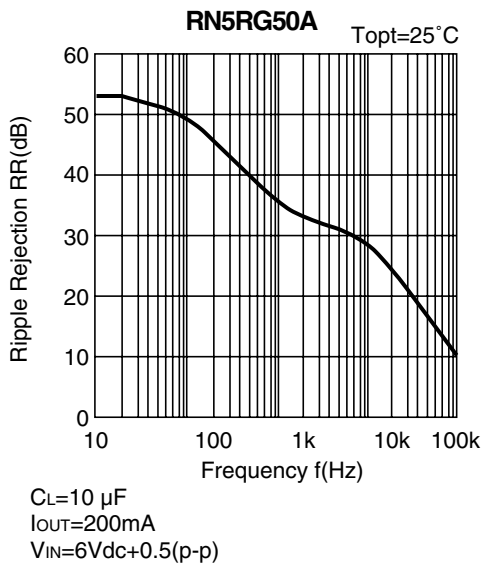

9) Line Transient Response (1)

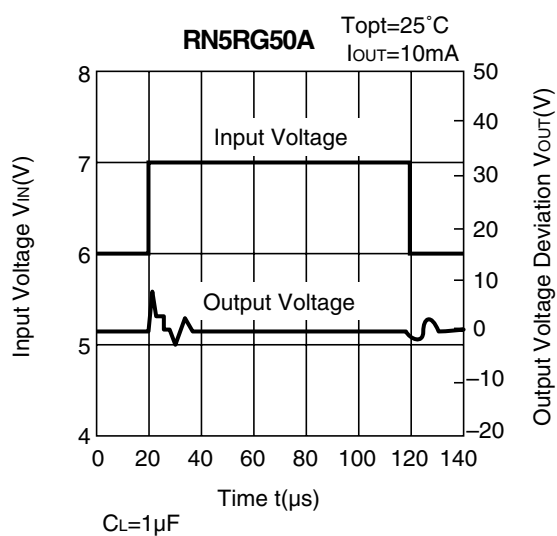

10) Line Transient Response (2)

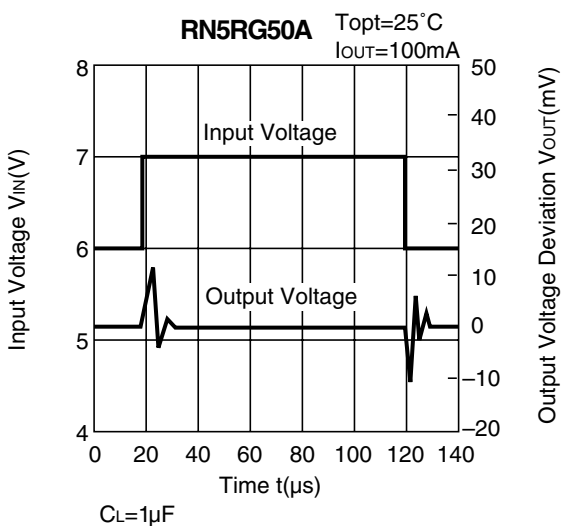

11) Load Transient Response

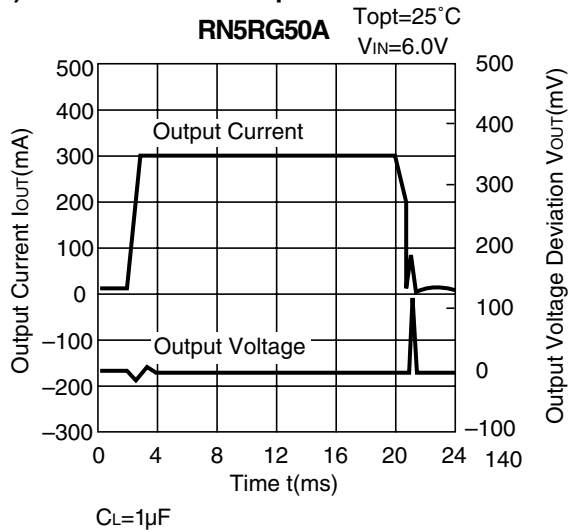

## TYPICAL APPLICATION

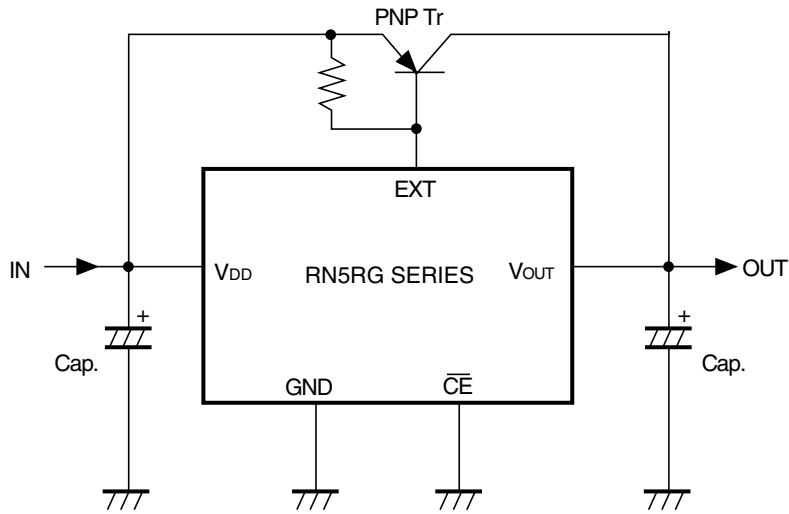

Parts Transistor : 2SA1213  
Resistor : 10k $\Omega$   
Capacitor : 10 $\mu$ F(tantalum type)