



20N15

Power MOSFET

20A, 150V N-CHANNEL POWER MOSFET

DESCRIPTION

The UTC **20N15** is an N-Channel POWER MOSFET, it uses UTC's advanced technology to provide customers with high switching speed and low gate charge.

The UTC **20N15** is suitable for bridge circuits, power converters and PWM motor controls.

FEATURES

- * $R_{DS(on)} < 0.13\Omega$ @ $V_{GS} = 10V, I_D = 10A$
- * High switching speed
- * Low gate charge

SYMBOL

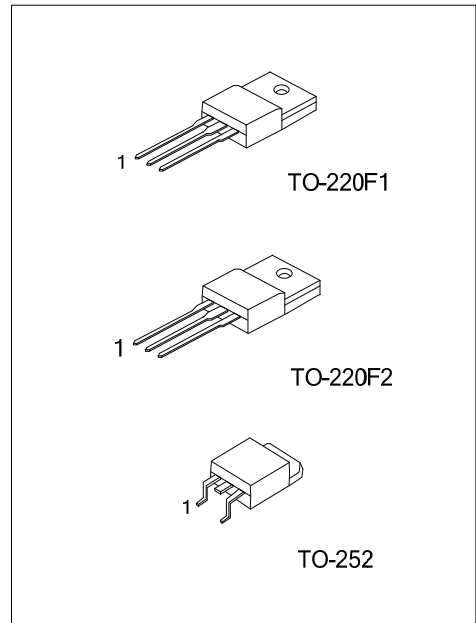
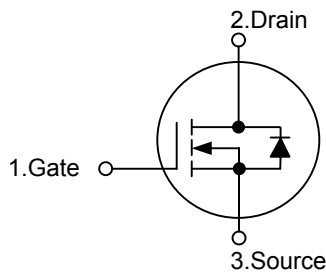

ORDERING INFORMATION

Ordering Number		Package	Pin Assignment			Packing
Lead Free	Halogen Free		1	2	3	
20N15L-TF1-T	20N15G-TF1-T	TO-220F1	G	D	S	Tube
20N15L-TF2-T	20N15G-TF2-T	TO-220F2	G	D	S	Tube
20N15L-TN3-T	20N15G-TN3-T	TO-252	G	D	S	Tube
20N15L-TN3-R	20N15G-TN3-R	TO-252	G	D	S	Tape Reel

Note: Pin Assignment: G: Gate D: Drain S: Source

<p>20N15L-TF1-T</p>	<p>(1) T: Tube, R: Tape Reel (2) TF1: TO-220F1, TF2: TO-220F2, TN3: TO-252 (3) L: Lead Free, G: Halogen Free</p>
---------------------	--

■ ABSOLUTE MAXIMUM RATINGS ($T_c=25^\circ\text{C}$, unless otherwise noted)

PARAMETER		SYMBOL	RATINGS	UNIT
Drain-Source Voltage		V_{DSS}	150	V
Gate-Source Voltage	Continuous	V_{GSS}	± 20	V
Drain Current	Continuous	I_D	20	A
	Single Pulsed ($t_p \leq 10\mu\text{s}$)	I_{DM}	60	A
Single Drain-to-Source Avalanche Energy	Starting $T_J=25^\circ\text{C}$ ($V_{DD}=120\text{V}$, $V_{GS}=10\text{V}$, $I_L=20\text{A}$, $L=0.3\text{mH}$)	E_{AS}	60	mJ
Power Dissipation	TO-220F1	P_D	36	W
	TO-220F2		38	W
	TO-252		50	W
Operating Temperature		T_J	+150	$^\circ\text{C}$
Storage Temperature Range		T_{STG}	-55~+150	$^\circ\text{C}$

Note: Absolute maximum ratings are those values beyond which the device could be permanently damaged. Absolute maximum ratings are stress ratings only and functional device operation is not implied.

■ THERMAL CHARACTERISTICS

PARAMETER		SYMBOL	RATINGS	UNIT
Junction to Ambient	TO-220F1/TO-220F2	θ_{JA}	62.5	$^\circ\text{C/W}$
	TO-252		110	$^\circ\text{C/W}$
Junction to Case	TO-220F1	θ_{JC}	3.47	$^\circ\text{C/W}$
	TO-220F2		3.28	$^\circ\text{C/W}$
	TO-252		2.5	$^\circ\text{C/W}$

■ ELECTRICAL CHARACTERISTICS ($T_J=25^\circ\text{C}$, unless otherwise noted)

PARAMETER	SYMBOL	TEST CONDITIONS	MIN	TYP	MAX	UNIT
OFF CHARACTERISTICS						
Drain-Source Breakdown Voltage	BV_{DSS}	$I_D=0.25\text{mA}$, $V_{GS}=0\text{V}$	150			V
Drain-Source Leakage Current	I_{DSS}	$V_{DS}=150\text{V}$, $V_{GS}=0\text{V}$			10	μA
		$V_{DS}=150\text{V}$, $V_{GS}=0\text{V}$, $T_J=125^\circ\text{C}$			100	μA
Gate-Source Leakage Current	Forward	I_{GSS}			100	nA
	Reverse					
					100	nA
		$V_{GS}=-20\text{V}$, $V_{DS}=0\text{V}$			100	nA
ON CHARACTERISTICS (Note 1)						
Gate Threshold Voltage	$V_{GS(TH)}$	$V_{DS}=V_{GS}$, $I_D=0.25\text{mA}$	2.0		4.0	V
Static Drain-Source On-State Resistance	$R_{DS(ON)}$	$V_{GS}=10\text{V}$, $I_D=10\text{A}$		0.12	0.13	Ω
Drain-Source On-Voltage	$V_{DS(ON)}$	$V_{GS}=10\text{V}$, $I_D=20\text{A}$			2.8	V
DYNAMIC PARAMETERS						
Input Capacitance	C_{ISS}	$V_{GS}=0\text{V}$, $V_{DS}=25\text{V}$, $f=1.0\text{MHz}$		1133	1627	pF
Output Capacitance	C_{OSS}			332	474	pF
Reverse Transfer Capacitance	C_{RSS}			105	174	pF
SWITCHING PARAMETERS (Note 2)						
Gate Charge	Q_G	$V_{GS}=10\text{V}$, $V_{DS}=75\text{V}$, $I_D=20\text{A}$		39.1	55.9	nC
	Q_{GS}			7.5		nC
	Q_{GD}			22		nC
Turn-ON Delay Time	$t_{D(ON)}$	$V_{DD}=75\text{V}$, $V_{GS}=10\text{V}$, $I_D=20\text{A}$, $R_G=9.1\Omega$		11	25	ns
Rise Time	t_R			77	153	ns
Turn-OFF Delay Time	$t_{D(OFF)}$			33	67	ns
Fall-Time	t_F			49	97	ns
SOURCE- DRAIN DIODE RATINGS AND CHARACTERISTICS						
Drain-Source Diode Forward Voltage (Note 1)	V_{SD}	$I_S=20\text{A}$, $V_{GS}=0\text{V}$			1.5	V
Maximum Continuous Drain-Source Diode Forward Current	I_S				20	A
Pulsed Drain-Source Current	I_{SM}				60	A
Body Diode Reverse Recovery Time	t_{RR}	$I_S=20\text{A}$, $V_{GS}=0\text{V}$, $dI_S/dt=100\text{A}/\mu\text{s}$		160		ns
Body Diode Reverse Recovery Charge	Q_{RR}			1.1		μC

Notes: 1. Pulse Test: Pulse Width $\leq 300\mu\text{s}$, Duty Cycle $\leq 2\%$.

2. Switching characteristics are independent of operating junction temperature.

TYPICAL CHARACTERISTICS

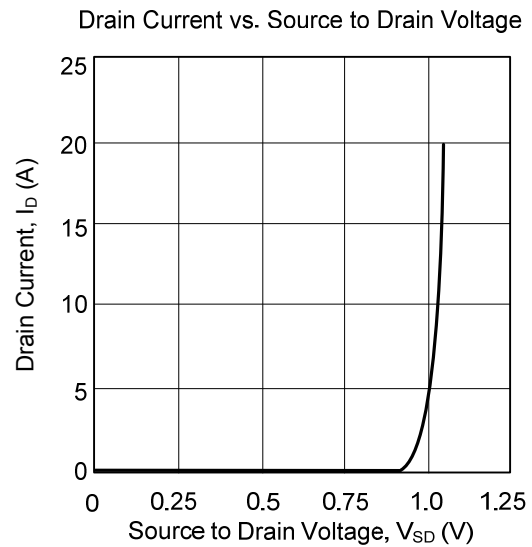
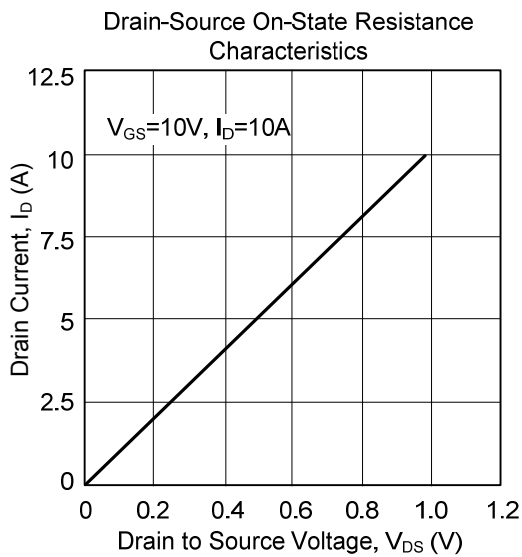
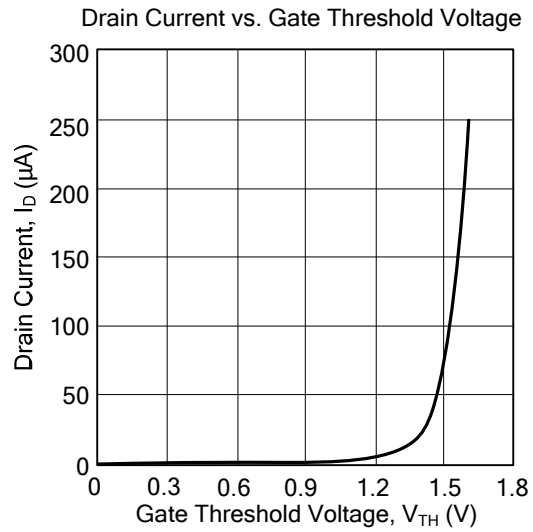
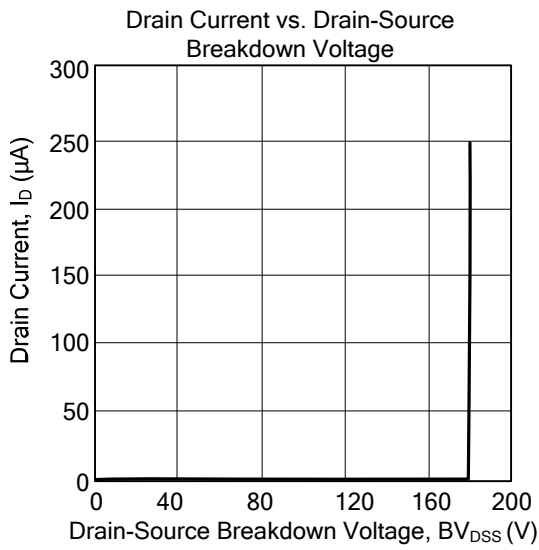

UTC assumes no responsibility for equipment failures that result from using products at values that exceed, even momentarily, rated values (such as maximum ratings, operating condition ranges, or other parameters) listed in products specifications of any and all UTC products described or contained herein. UTC products are not designed for use in life support appliances, devices or systems where malfunction of these products can be reasonably expected to result in personal injury. Reproduction in whole or in part is prohibited without the prior written consent of the copyright owner. The information presented in this document does not form part of any quotation or contract, is believed to be accurate and reliable and may be changed without notice.