



TAI-SAW TECHNOLOGY CO., LTD.

No. 3, Industrial 2nd Rd., Ping-Chen Industrial District,
Taoyuan, 324, Taiwan, R.O.C.

TEL: 886-3-4690038 FAX: 886-3-4697532

E-mail: tstsales@mail.taisaw.com Web: www.taisaw.com

Product Specifications Approval Sheet

Product Description: LVDS SAW Oscillator 231.25MHz SMD 7.0X5.0 mm

TST Part No.: TS0014A

Customer Part No.: _____

Customer signature required
Company: _____
Division: _____
Approved by : _____
Date: _____

Checked by: Paul Ni *Paul Ni*

Approved by: Francis Chen *Francis Chen*

Date: 2010/10/27

1. Customer signed back is required before TST can proceed with sample build and receive orders.
2. Orders received without customer signed back will be regarded as agreement on the specifications.
3. Any specifications changes must be approved upon by both parties and a new revision of specifications shall be released to reflect the changes.



TAI-SAW TECHNOLOGY CO., LTD.

No. 3, Industrial 2nd Rd., Ping-Chen Industrial District,
Taoyuan, 324, Taiwan, R.O.C.

TEL: 886-3-4690038 FAX: 886-3-4697532

E-mail: tstsales@mail.taisaw.com Web: www.taisaw.com

SMD 7.0x5.0 LVDS SAW Oscillator

MODEL NO.: TS0014A

REV. NO.:2.0

RoHS Compliant
Lead free
Lead-free soldering

Conditions:

Parameter	Symbol	Limits			Units
		min.	typ.	max.	
Supply Voltage	V _{CC}	2.375	2.5	2.625	V
Load Impedance	-	-	100	-	Ω
Operating Temperature Range	-	-10	-	70	°C

Electrical Specifications:

For different applications, the specification change is possible. Please contact TST sales representative or application engineer for your requirement.

Parameter	Condition	Limits			Units
		min.	typ.	max.	
Nominal Frequency	-	-	231.25	-	MHz
Current Consumption	Both output loaded	-	48	60	mA
Frequency tolerance	-	-100	-	100	ppm
Output clock duty cycle	-	45	48.0	55	%
High output voltage	I _{OH} =8mA	-	-	1.6	V
Low output voltage	I _{OL} =8mA	0.9	-	-	V
LVDS Rise time	80%/20% -V _{CC} level	-	0.38	0.7	ns
LVDS Fall time	80%/20% -V _{CC} level	-	0.37	0.7	ns
Oscillation Start Up time	Time at min. supply voltage to be 0 sec.	-	2.0	10	msec.
Phase Jitter	Integration of Phase noise Offset 12KHz~20 MHz	-	0.22	1	ps
Frequency Aging	25 deg.C 1 st year.	-	-	+10	ppm/yr

Phase Noise :

Parameter	Symbol	Limits			Units	Conditions
		min.	typ.	max.		
Phase Noise @ 100Hz	PN1	-	-90	-	dBc/Hz	-
Phase Noise @ 1KHz	PN1	-	-119	-	dBc/Hz	-
Phase Noise @ 10 KHz	PN2	-	-140	-	dBc/Hz	-
Phase Noise @ 100KHz	PN3	-	-145	-	dBc/Hz	-
Phase Noise @ 1MHz	PN4	-	-145	-	dBc/Hz	-

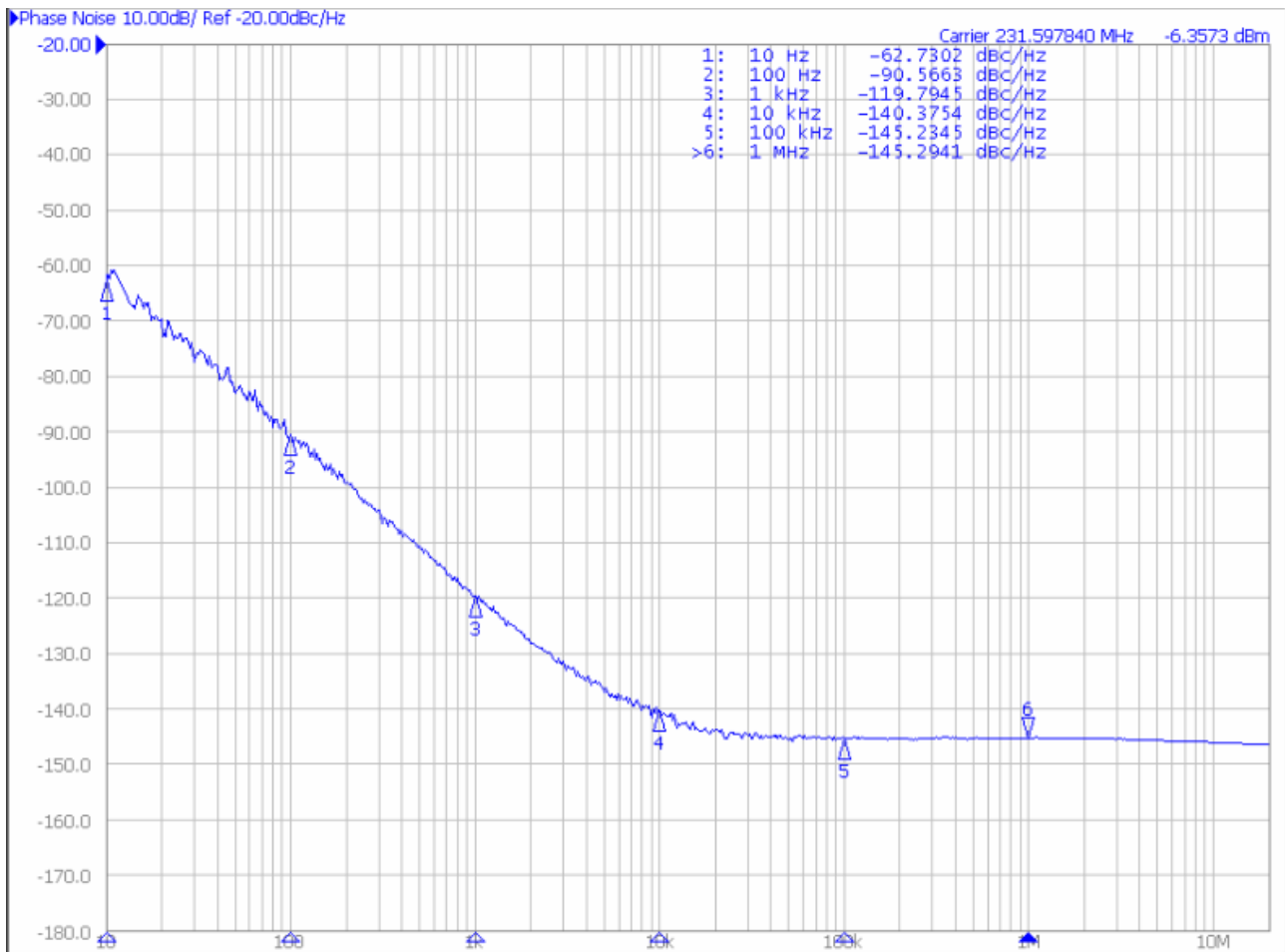

Mechanical Dimensions (mm):

- LVDS SO TS0014A PACKAGE DIM.:

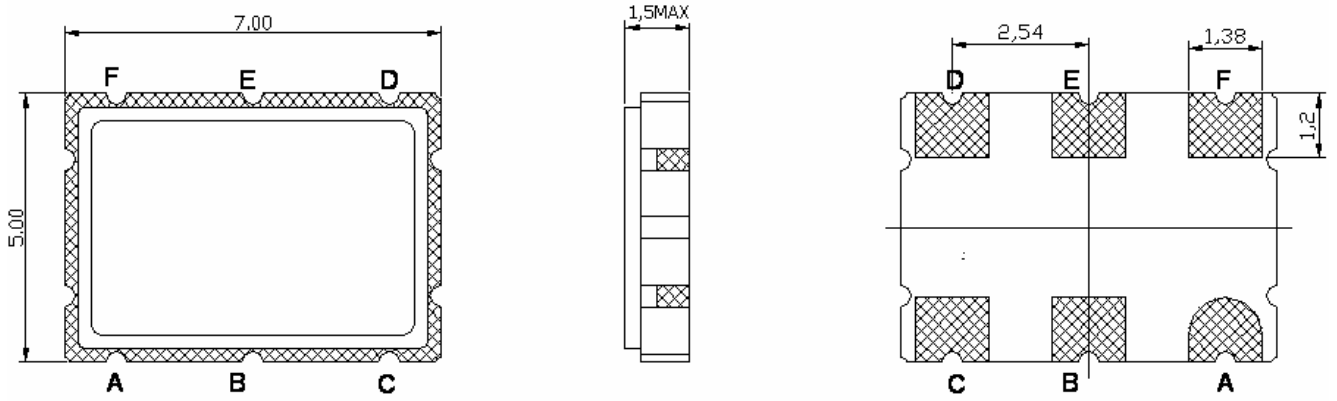

- Recommended customer PCB Layout footprint (mm):

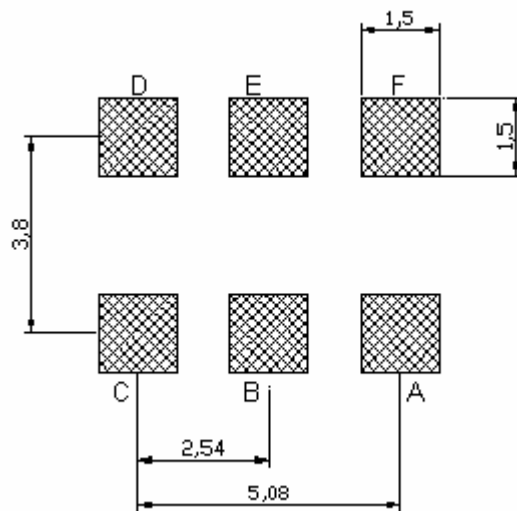

Marking:

Line 1: TST P/N (TS0014A)

Line 2: TST Logo + SO Product Code + Date Code

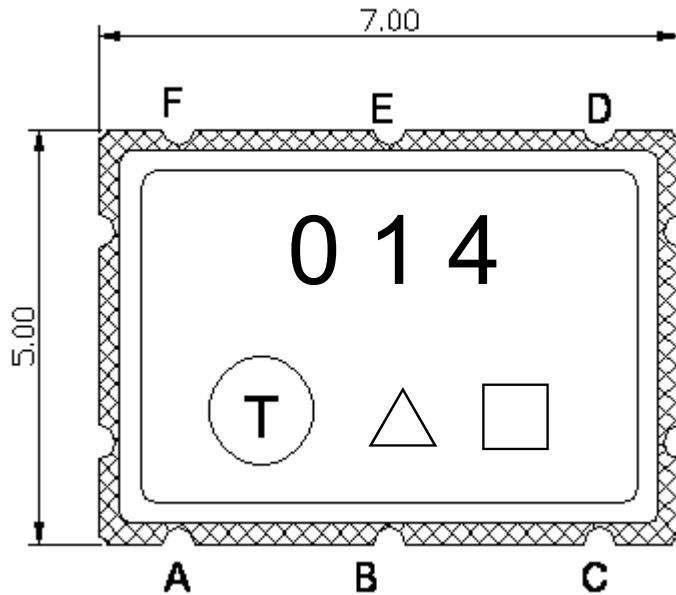

Pin	Connection
A	OE
B	N.C.
C	GND
D	OUT
E	$\overline{\text{OUT}}$
F	Vcc

Product Code Table:

Year	2009 2013	2010 2014	2011 2015	2012 2016
Product Code	S	s	<u>S</u>	<u>s</u>

Date Code Table:

WK01	WK02	WK03	WK04	WK05	WK06	WK07	WK08	WK09	WK10	WK11	WK12	WK13
A	B	C	D	E	F	G	H	I	J	K	L	M
WK14	WK15	WK16	WK17	WK18	WK19	WK20	WK21	WK22	WK23	WK24	WK25	WK26
N	O	P	Q	R	S	T	U	V	W	X	Y	Z
WK27	WK28	WK29	WK30	WK31	WK32	WK33	WK34	WK35	WK36	WK37	WK38	WK39
a	b	c	d	e	f	g	h	i	j	k	l	m
WK40	WK41	WK42	WK43	WK44	WK45	WK46	WK47	WK48	WK49	WK50	WK51	WK52
n	o	p	q	r	s	t	u	v	w	x	y	z

Tape & Reel:

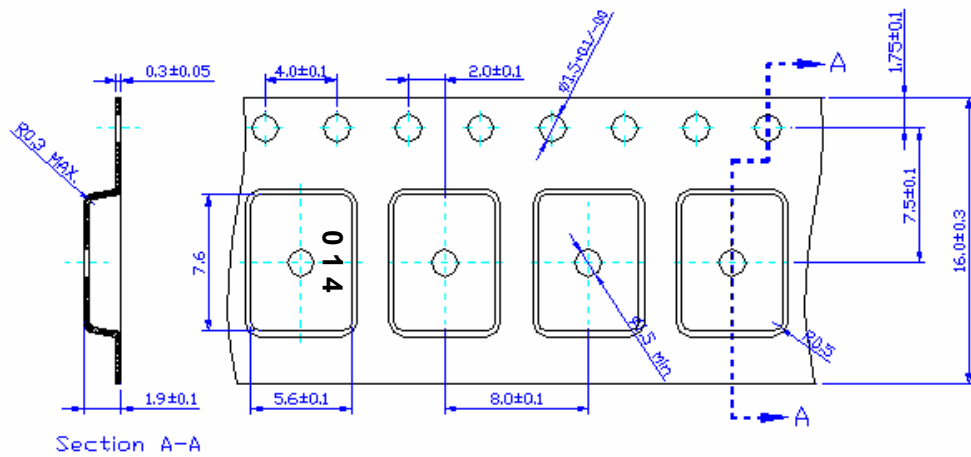
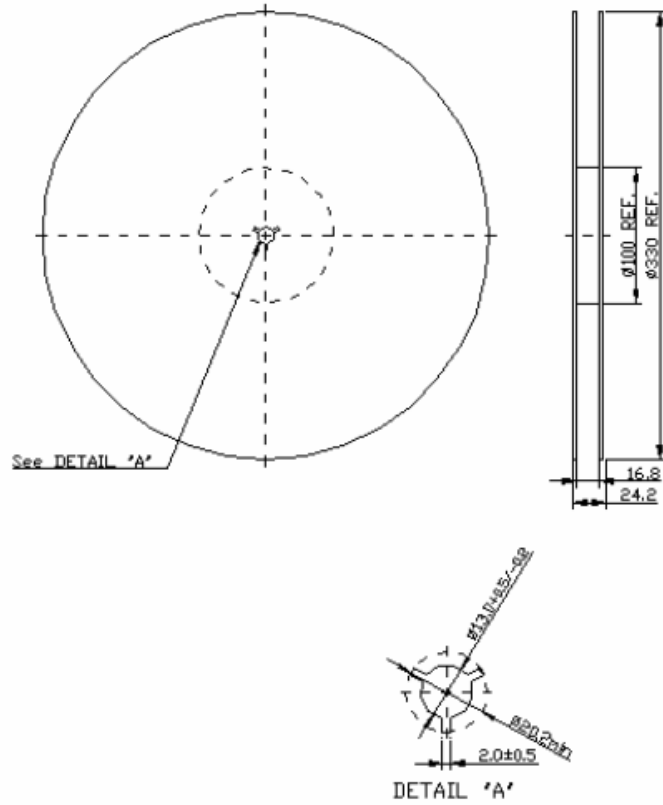

[NOTE]

1. UNIT : MM.
2. UNLESS OTHERWISE SPECIFIED TOLERANCE ON DIM. +/-0.1MM.
3. MATERIAL : CONDUCTIVE POLYSTYRENE.
4. COLOR : BLACK.
5. 10 PITCH CUMULATIVE TOLERANCE +/-0.2MM.

RECOMMENDED REFLOW PROFILE:

