



FEATURES

- Operating Voltage from 2.6V to 5.5V
- Adjustable Output Voltage Range up to 27V
- Up to 3A Output Switch Current
- 680K/1.2MHz Selectable Switching Frequency
- Programmable Soft-start Function
- External Compensation Network
- Current Limit and Thermal Shutdown Protection
- Under Voltage Lockout
- $\leq 1\mu\text{A}$ Shutdown Current
- Available in the Pb-Free MESOP-10, MESOP-8, TDFN 3x3-10L and ESOP-8 Packages

DESCRIPTION

The APE1920 is a high performance, high efficiency step up DC-DC Converter with integrated 3A. The APE1920 converter input voltage ranging from 2.6 to 5.5V. The Output voltage can be set up to 27V. The selectable frequency of 680 kHz and 1.2 MHz allows the use of small external inductors and capacitors and provides fast transient response. Current mode control with external compensation network makes it easy to stabilize the system and keep maximum flexibility. Programmable soft start function minimizes impact on the input power system. Internal power MOSFET with very low RDS (ON) provides high efficiency. The APE1920 automatically transits from PWM to PFM during light load condition further increasing efficiency. The converter also provides protection functions such as Current Limit and Thermal shutdown. The APE1920 is available in space-saving MESOP-10, MESOP-8, TDFN 3x3-10L and ESOP-8 packages.

TYPICAL APPLICATION

1.FREQ=High (Frequency=1.2MHz) (MESOP-10 and TDFN 3x3-10L)

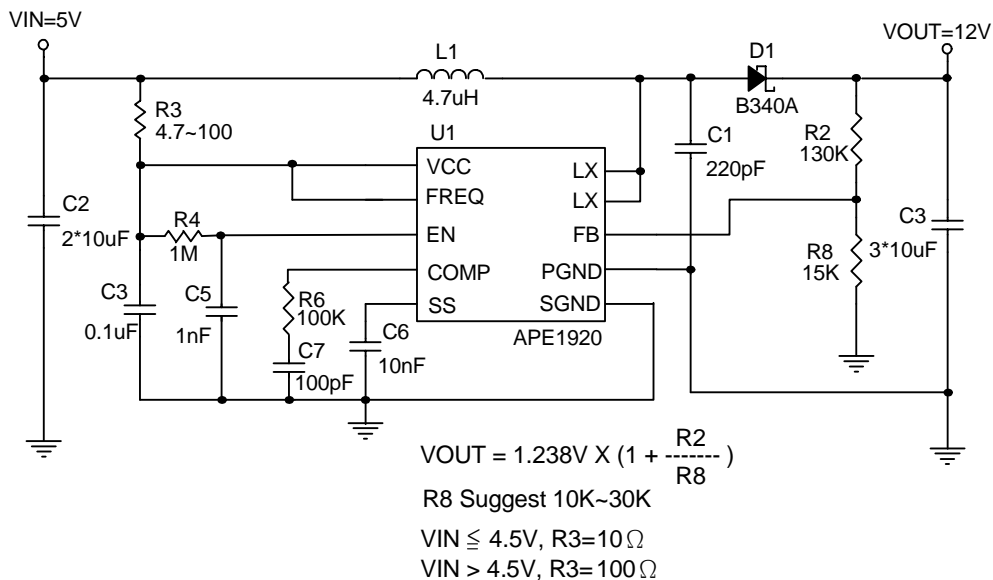



TYPICAL APPLICATION

(2) FREQ=Low (Frequency=680KHz) (MESOP-10 and TDFN 3x3-10L)

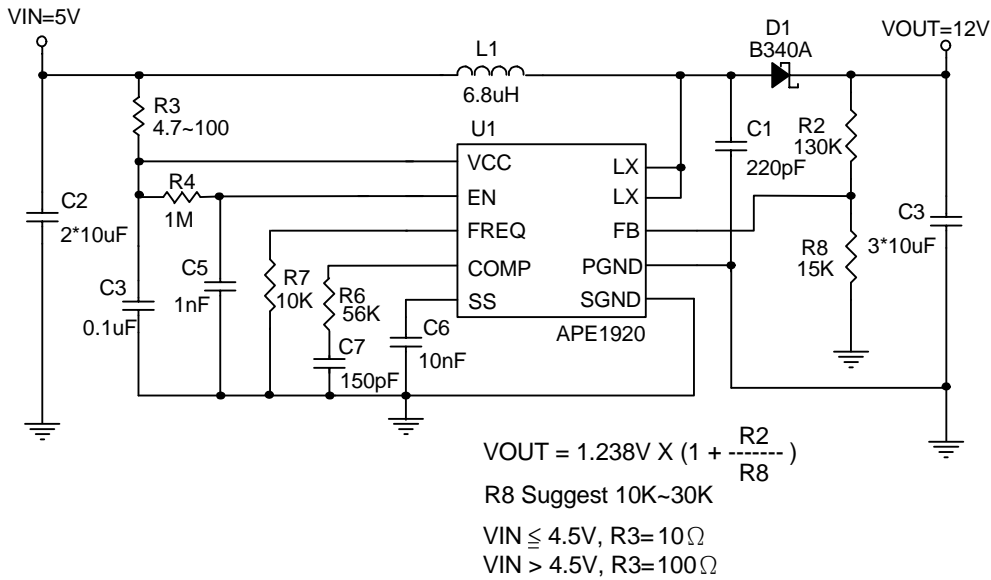

(3) FREQ=High (Frequency=1.2MHz) (ESOP-8/MESOP-8)

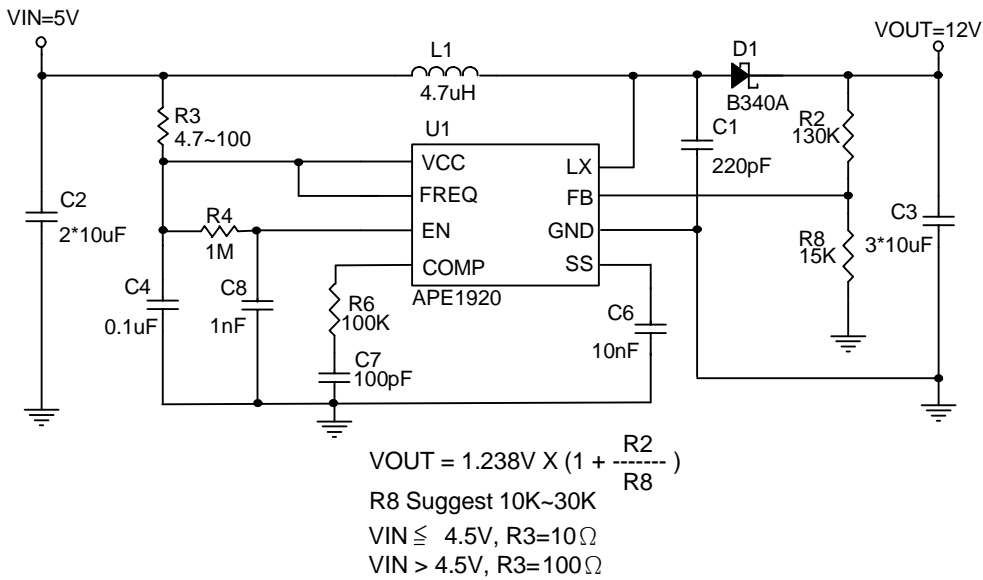



TYPICAL APPLICATION

(4) FREQ=Low (Frequency=680KHz) (ESOP-8/MESOP-8)

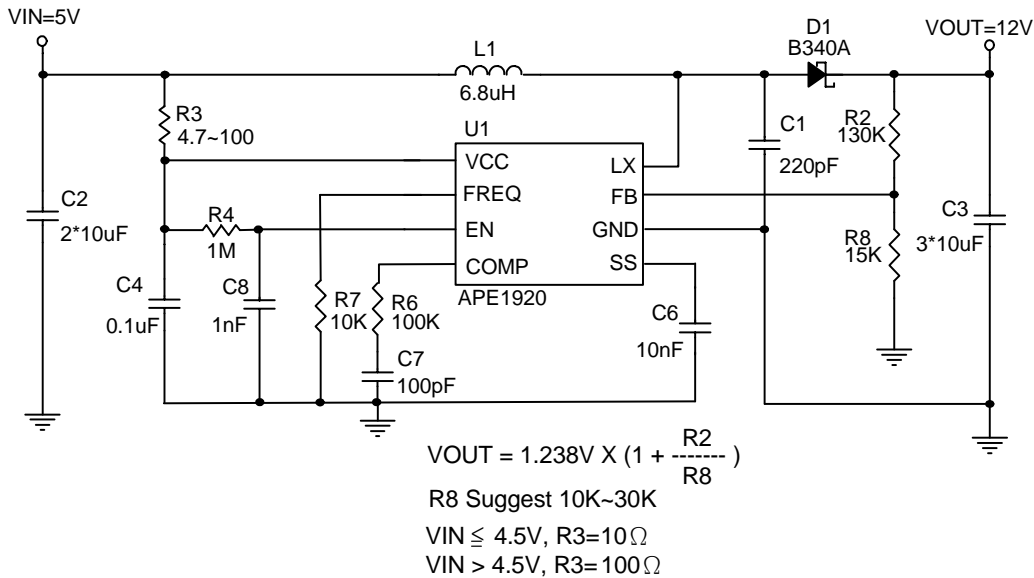

ORDERING / PACKAGE INFORMATION

APE1920X
 Package Type
 MP : ESOP-8
 MM8 : MESOP-8
 MM10 : MESOP-10
 TGN3 : TDFN 3x3-10L

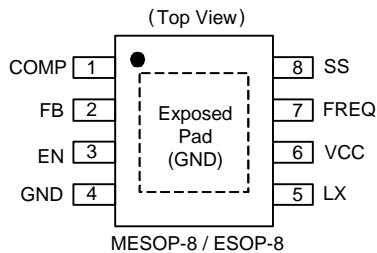
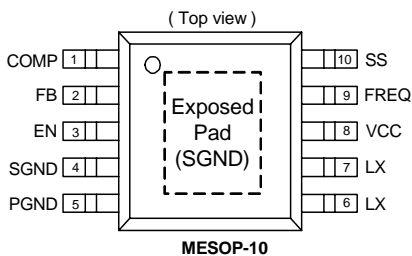
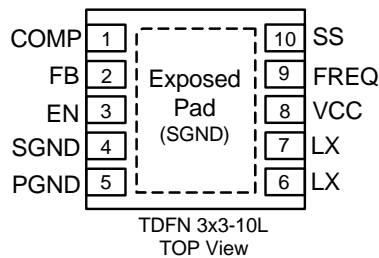



ABSOLUTE MAXIMUM RATINGS (at $T_A=25^\circ\text{C}$)

V_{CC} Pin Voltage (V_{CC})	-----	GND - 0.3 to GND + 6V
EN, FREQ, COMP, FB, SS, Pin Voltage	-----	GND - 0.3 to $V_{CC} + 0.3\text{V}$
LX Pin Voltage (V_{LX})	-----	30V
Power Dissipation (P_D)	-----	$(T_J - T_A) / R_{thja}$ mW
Storage Temperature Range (T_{ST})	-----	-65°C To 150°C
Operating Junction Temperature Range (T_{OP})	-----	-40 to $+125^\circ\text{C}$
Thermal Resistance from Junction to Case		
	ESOP-8	15°C/W
	MESOP-8	30°C/W
	MESOP-10	30°C/W
	TDFN 3x3-10L	20°C/W
Thermal Resistance from Junction to Ambient		
	ESOP-8	40°C/W
	MESOP-8	80°C/W
	MESOP-10	80°C/W
	TDFN 3x3-10L	55°C/W

Note: R_{thja} is measured with the PCB copper area of approximately 1.5 in^2 (Multi-layer). That copper area needs connect to exposed pad.

ELECTRICAL SPECIFICATIONS

($V_{IN}=5\text{V}$, $V_{OUT}=12\text{V}$, $V_{EN}=V_{IN}$, $T_A=25^\circ\text{C}$, unless otherwise noted)

Parameter	SYM	TEST CONDITION	MIN	TYP	MAX	UNITS
Input Voltage Range	V_{CC}		2.6	-	5.5	V
Under Voltage Lockout	UVLO	Rising	-	2.35	2.6	V
UVLO Hysteresis			-	-150	-	mV
Step-Up Voltage Adjust Range	V_{OUT}		$V_{CC}+0.5$	-	27	V
Operating Quiescent Current	I_{CCQ}	$I_{OUT}=0\text{mA}$, $V_{FB}=1.5\text{V}$	-	150	250	μA
Shutdown Current	I_{SD}	$V_{EN}=0\text{V}$	-	0.1	1	μA
Feedback Voltage	V_{FB}		1.219	1.238	1.257	V
FB Input Leakage Current	I_{FB-LKG}	$V_{FB} = 1.5\text{V}$	-100	0.01	100	nA
Line Regulation		$V_{IN}=2.6$ to 5.5V , $I_{OUT}=20\text{mA}$	-	0.2	-	%
Load Regulation		$V_{IN}=5\text{V}$, $I_{OUT}=1\text{mA}$ to 0.7A	-	0.3	-	%
Oscillator Frequency	F_{OSC}	FREQ=High	900	1200	1500	KHz
		FREQ=Low	500	680	850	
FREQ High-level Input Voltage	V_{FQ-IH}		2	-	-	V
FREQ Low-level Input Voltage	V_{FQ-IL}		-	-	0.5	
FREQ Input Leakage Current	I_{FQ-LKG}	FREQ=GND	-	-	0.1	μA
Soft Start Current	I_{SS}		4	7	13	μA
N-channel MOSFET Current Llimit	I_{LIM}	Duty=40%	3	3.8	4.5	A



ELECTRICAL SPECIFICATIONS(Cont.)

Parameter	SYM	TEST CONDITION	MIN	TYP	MAX	UNITS
MOSFET On-resistance (Note1)	$R_{DS(on)}$	$V_{IN}=3V, I_{SW}=2A$	-	200	280	mΩ
		$V_{IN}=5V, I_{SW}=2A$	-	160	220	
EN High-level Input Voltage	V_{IH}		1	-	-	V
EN Low-level Input Voltage	V_{IL}		-	-	0.4	V
EN Hysteresis	hys		-	200	-	mV
EN Input Leakage Current	I_{EN-LKG}	$V_{EN}=GND$ or V_{IN}	-	0.01	0.1	μA
Maximum Duty Cycle	Duty	$V_{FB}=0V$	85	90	-	%
LX Leakage Current	I_{LXL}	$V_{LX} = 25V, V_{FB}=1.5V$	-	-	10	μA
Thermal Shutdown	T_{DS}		-	150	-	°C
Thermal Shutdown Hysteresis	T_{SH}		-	35	-	

Note : Guaranteed by design.

PIN DESCRIPTIONS

PIN SYMBOL	PIN DESCRIPTION
EN	Enable Pin
COMP	Compensation Pin
FB	Feedback Pin
SS	Soft start Pin. Connect a capacitor to GND
LX	Switch Pin.
V_{CC}	Power Input Pin
GND	Ground Pin
SGND	Signal Ground
PGND	Power Ground
FREQ	Frequency select pin. The power switch operates at 680kHz if FREQ is connected to GND and at 1.2MHz if FREQ is connected to VCC

BLOCK DIAGRAM

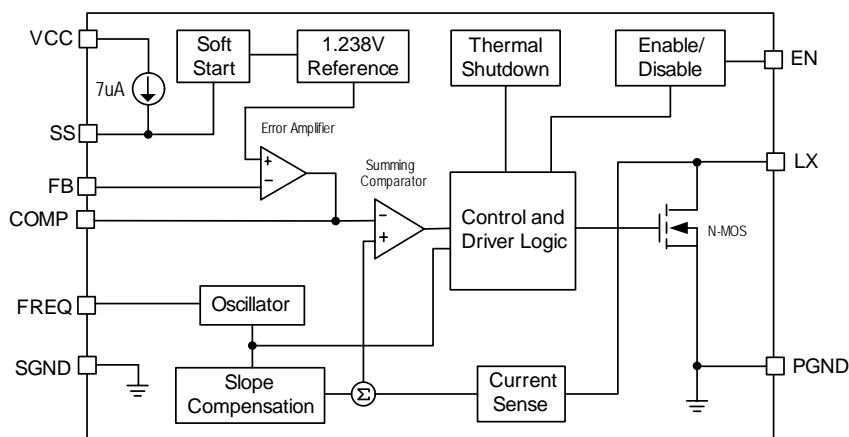



COMPENSATION TABLE

Frequency(Hz)	L1 (H)	VIN (V)	VOUT (V)	R6 (Ω)	C7 (F)
680K(FREQ=Low)	6.8u	2.5~4.4	5	10K	1.2n
		2.5~5.5	7	15K	470p
		2.5~5.5	9	27K	270p
		2.5~5.5	12	56K	150p
		2.5~5.5	15	150K	120p
		2.5~5.5	18	110K	100p
		2.5~5.5	21	150K	82p
		2.5~5.5	24	100K	47p
1.2M(FREQ=High)	4.7u	2.5~4.0	5	33K	1n
		2.5~5.5	7	39K	390p
		2.5~5.5	9	39K	220p
		2.5~5.5	12	100K	100p
		2.5~5.5	15	130K	68p
		2.5~5.5	18	150K	56p
		2.5~5.5	21	220K	47p
		2.5~5.5	24	390K	39p

APPLICATION INFORMATION

Setting the Output Voltage

Application circuit item shows the basic application circuit with APE1920 adjustable output version. The external resistor sets the output voltage according to the following equation:

$$V_{out} = 1.238V \times \left(1 + \frac{R2}{R8}\right)$$

For most applications, R8 is a suggested a value by 10~30KΩ. Place the resistor-divider as close to the IC as possible to reduce the noise sensitivity.

Soft Start Capacitor

The soft-start function begins from SS pin Voltage=0V to VCC with a 7uA (typ.) constant current charging to the soft-start capacitor, so the capacitor should be large enough to let the output voltage reach regulation inside the soft-start cycle. Typical value of soft-start capacitor range is from 4.7nF to 100nF. After the cycle finished, the load can start to draw maximum current as required.

Frequency Select Pin (FREQ)

The frequency select pin FREQ allows to set the switching frequency of the device to 680 KHz (FREQ = low) or 1.2 MHz (FREQ = high). Higher switching frequency improves load transient response but reduces slightly the efficiency. The other benefits of higher switching frequency are a lower output ripple voltage. Usually, it is recommended to use 1.2 MHz switching frequency unless light load efficiency is a major concern.



APPLICATION INFORMATION

Under Voltage Lockout (UVLO)

To avoid mis-operation of the device at low input voltages an under voltage lockout is included that disables the device, if the input voltage falls below (2.35V-150mV).

Input Capacitor Selection

For better input bypassing, low-ESR ceramic capacitors are recommended for performance. Two parallel 10uF (or one 22uF) input capacitor is sufficient for most applications. For a lower output power requirement application, this value can be decreased.

Output Capacitor Selection

For lower output voltage ripple, low-ESR output capacitor like ceramic capacitor is recommended. Three parallel 10uF ceramic capacitors work for most of the applications. Higher capacitor values can be used to improve the load transient response and reduce output ripple.

Layout Guide

(1) MESOP-10/TDFN 3x3-10L

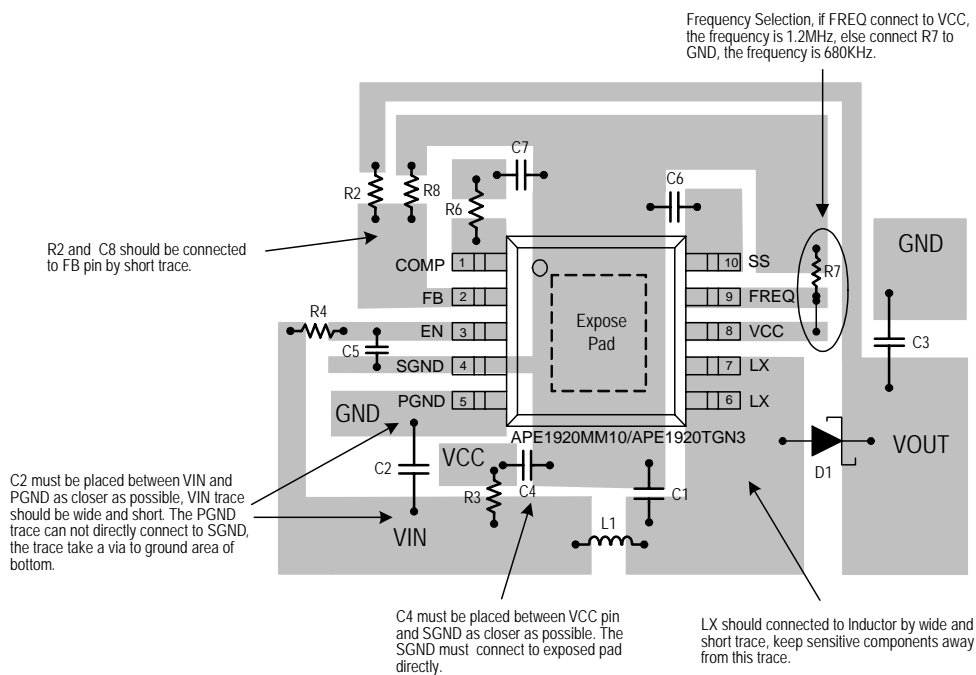



Layout Guide

(2) MESOP-8/ESOP-8

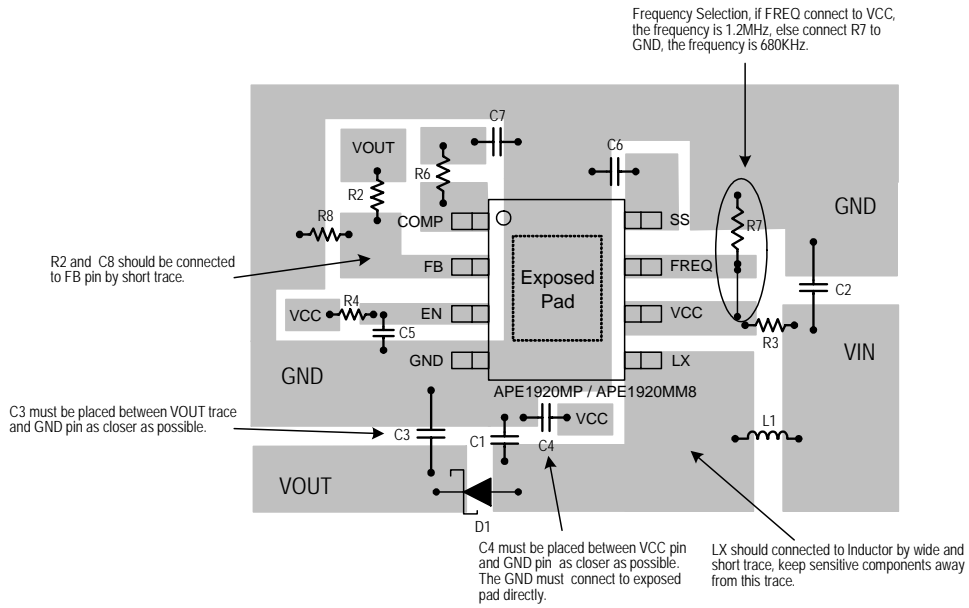



TYPICAL PERFORMANCE CHARACTERISTICS

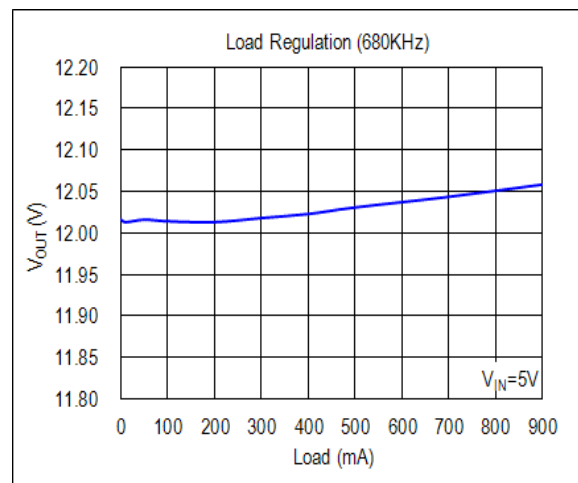
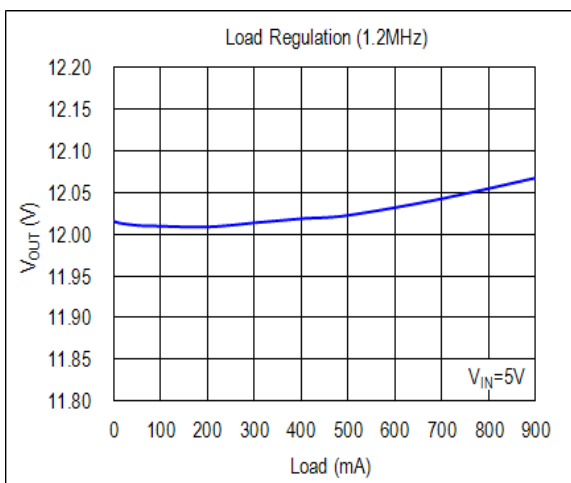
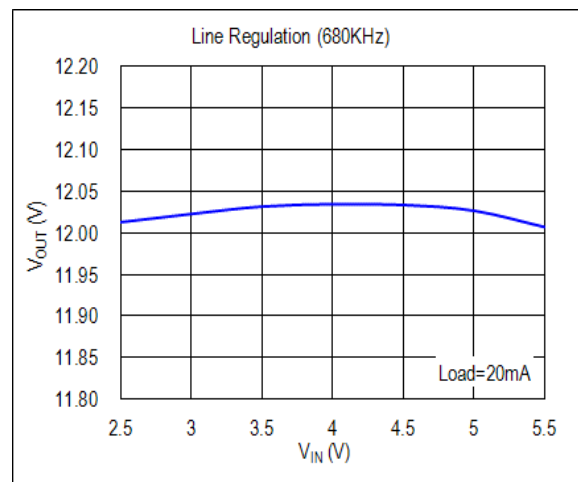
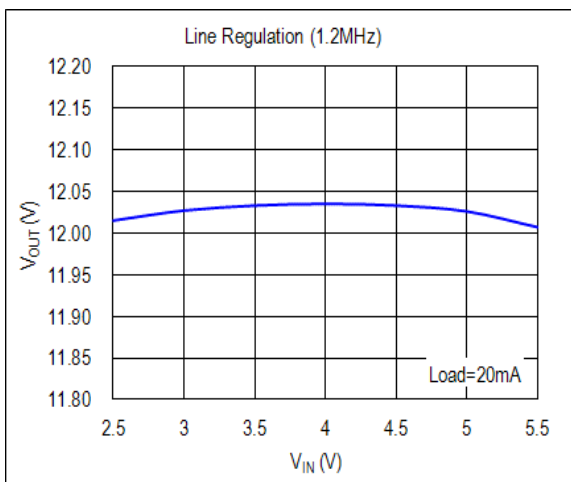
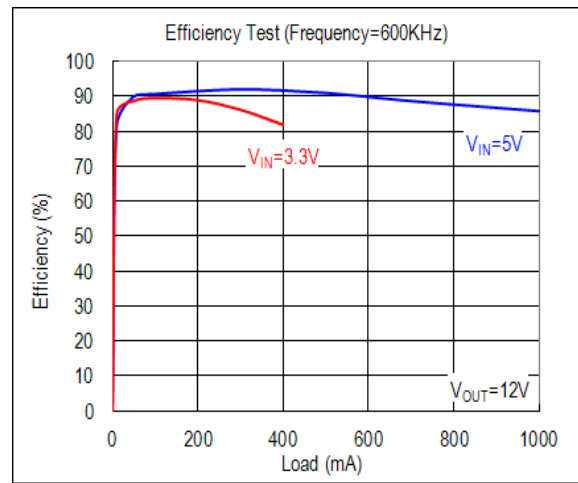
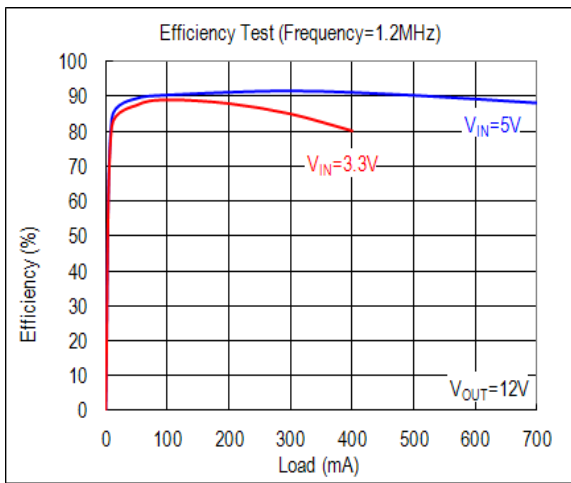



TYPICAL PERFORMANCE CHARACTERISTICS

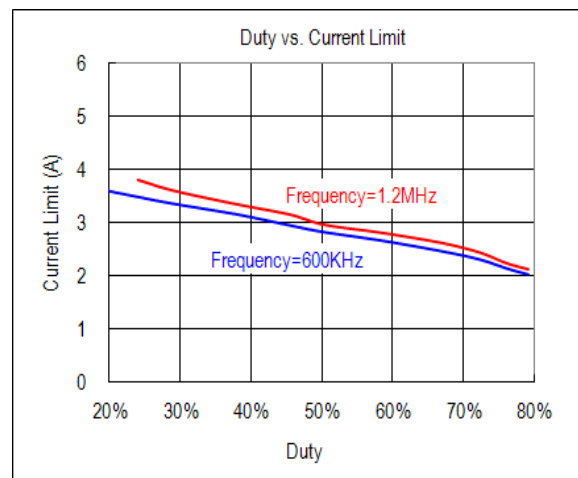
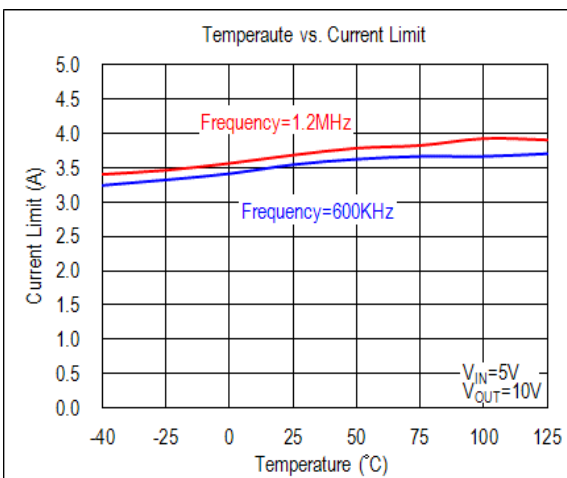
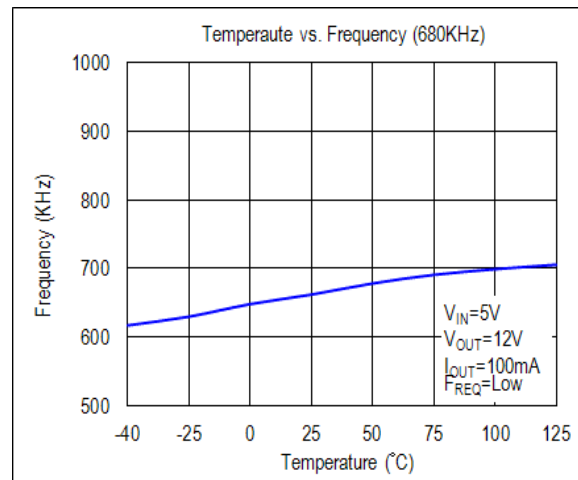
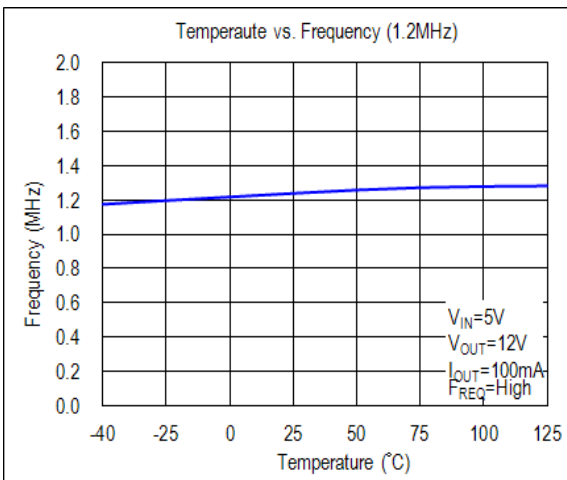
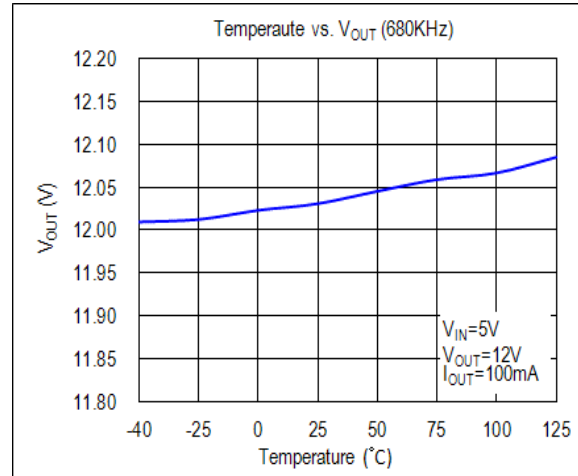
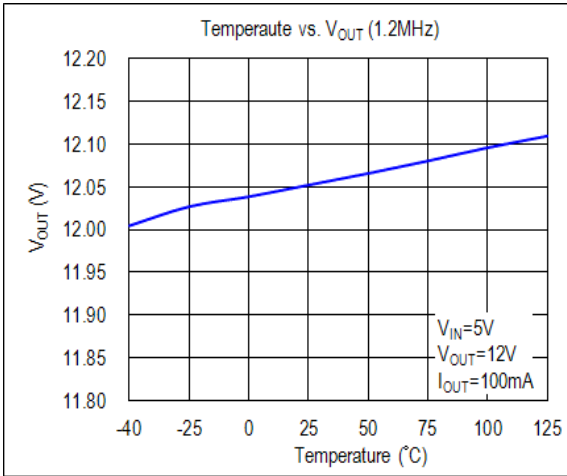



TYPICAL PERFORMANCE CHARACTERISTICS

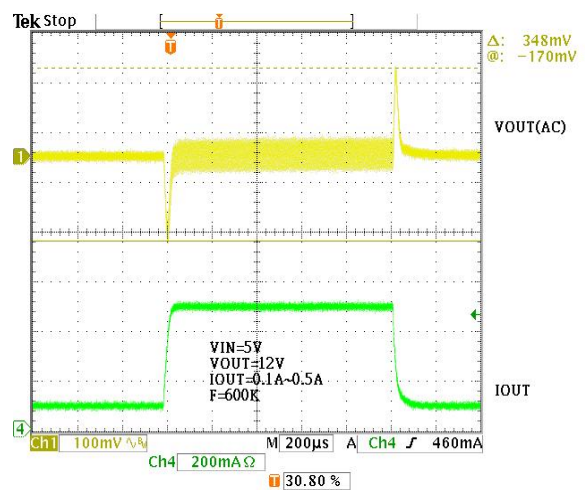
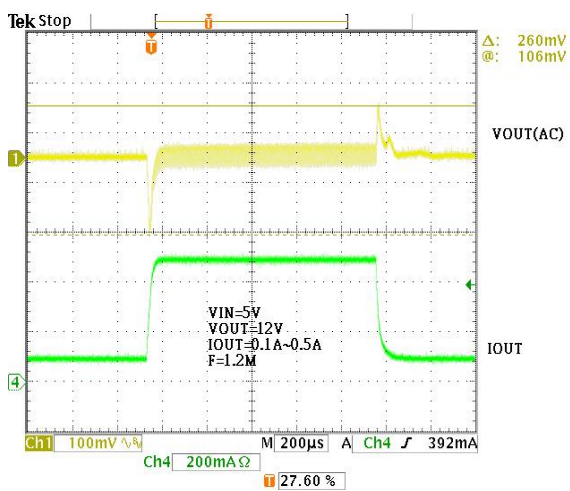
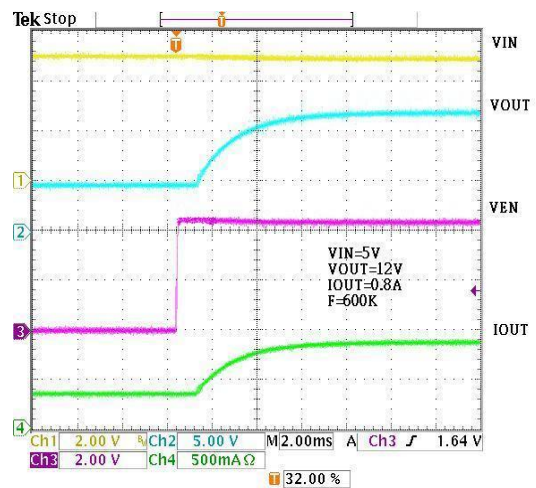
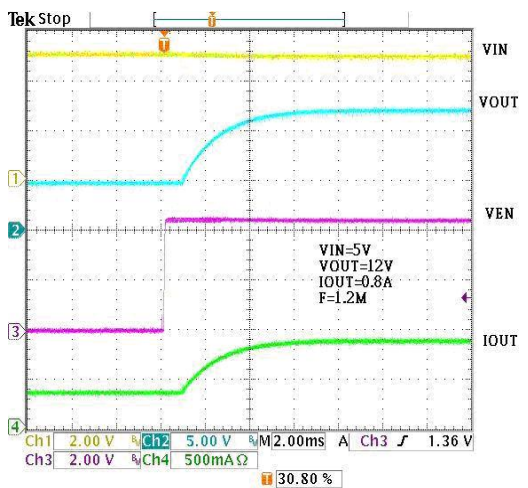
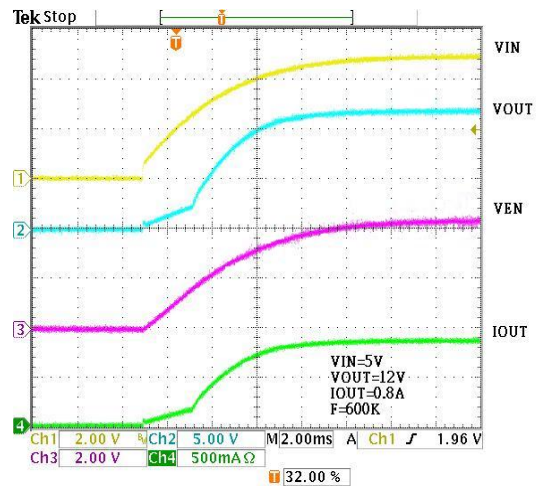
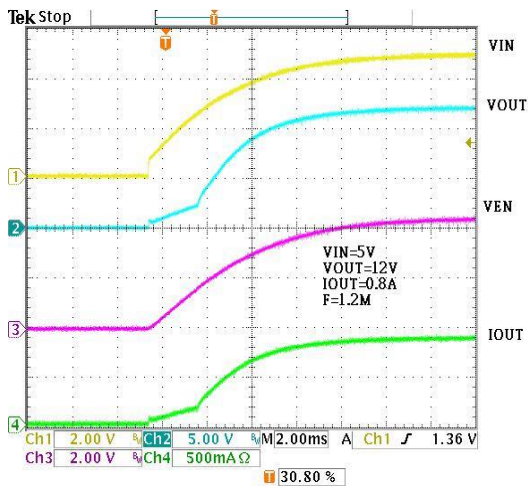



MARKING INFORMATION

ESOP-8

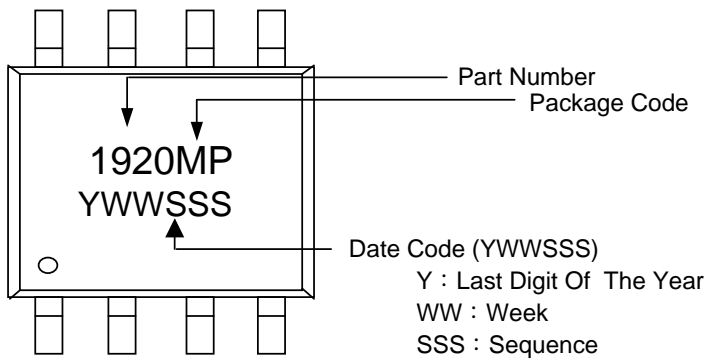

MESOP-8

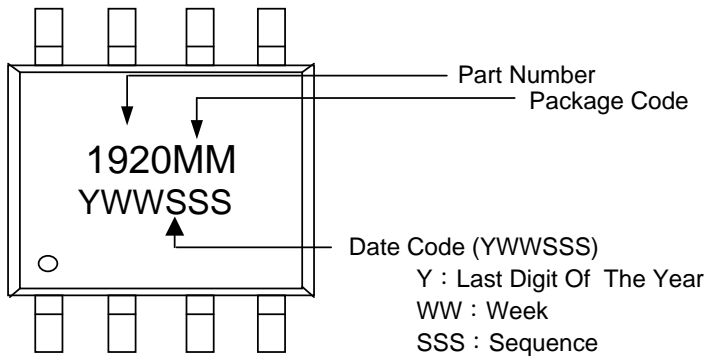

MESOP-10

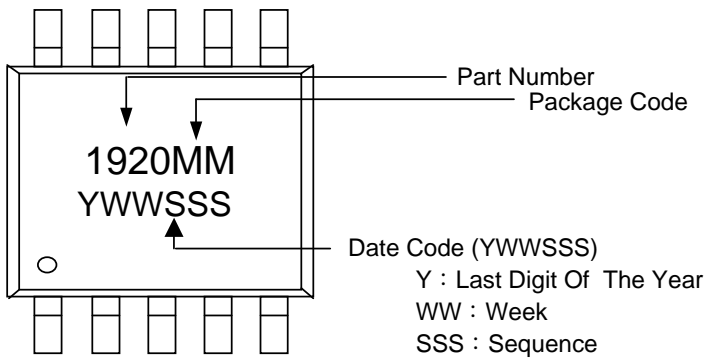

TDFN 3x3-10L

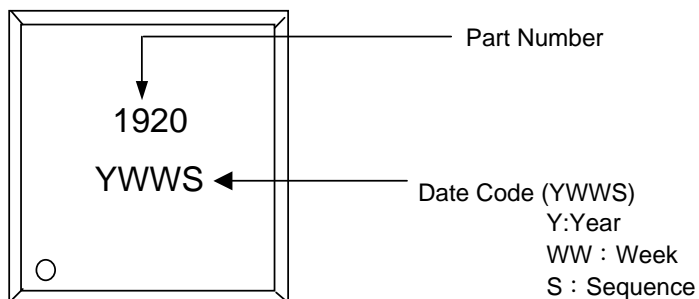



PACKAGE OUTLINES
MESOP-10

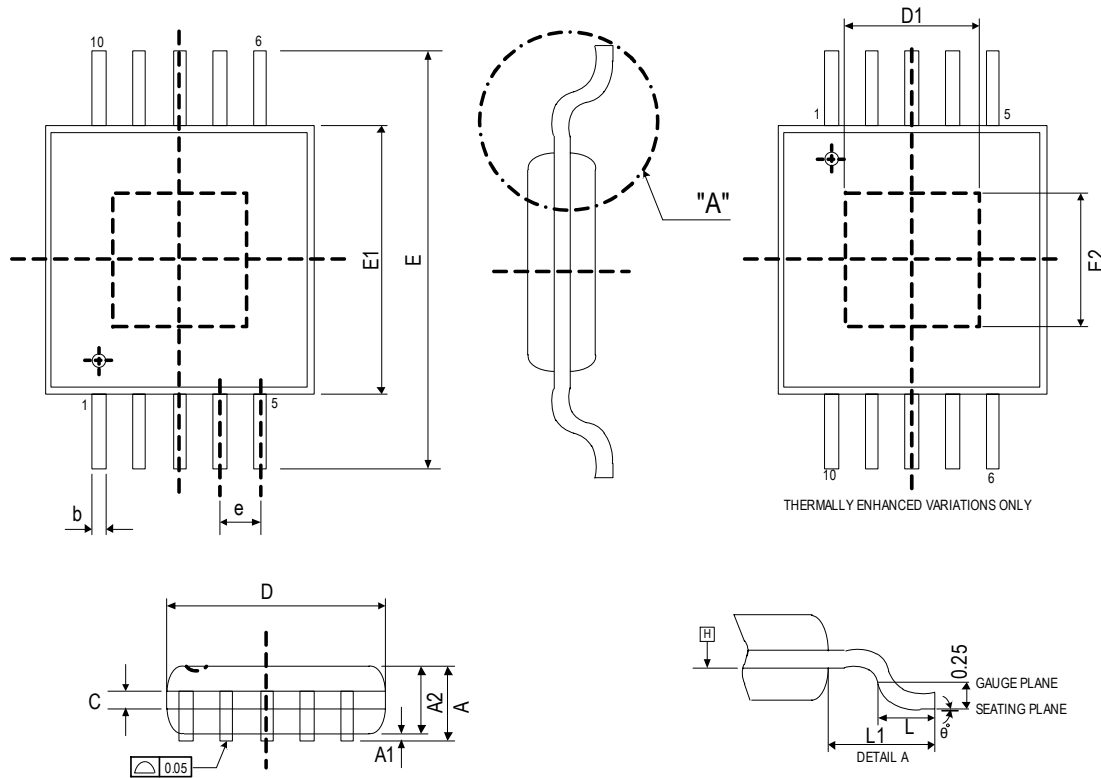

Symbol	Dimensions in Millimeters			Dimensions in Inches		
	Min.	Nom.	Max.	Min.	Nom.	Max.
A	-	-	1.1	-	-	0.043
A1	0	0.08	0.15	0	0.003	0.006
A2	0.75	0.85	0.95	0.03	0.034	0.038
C	0.08	0.15	0.23	0.003	0.006	0.009
D	2.9	3	3.1	0.114	0.118	0.122
D1	0.75	1.63	2.5	0.03	0.064	0.098
E	4.8	4.9	5	0.189	0.193	0.197
E1	2.9	3	3.1	0.114	0.118	0.122
E2	0.75	1.63	2.5	0.03	0.064	0.098
L	0.4	0.6	0.8	0.016	0.024	0.031
b	0.22	0.3	0.38	0.009	0.012	0.015
e	0.50 BSC			0.020 BSC		
y	-	-	0.1	-	-	0.004
θ	0°	-	8°	0°	-	8°

JEDEC outline: MO-187 BA-T



MESOP-8

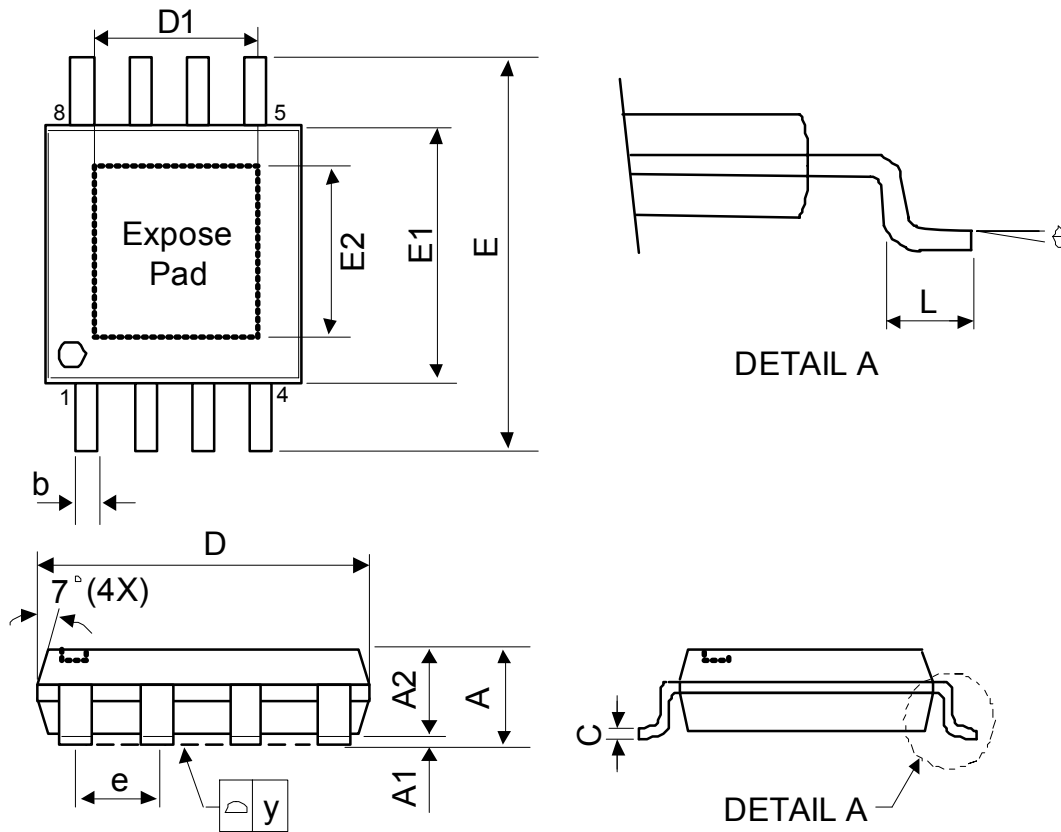

Symbol	Dimensions in Millimeters			Dimensions in Inches		
	Min.	Nom.	Max.	Min.	Nom.	Max.
A	-	-	1.1	-	-	0.043
A1	0	0.08	0.15	0	0.003	0.006
A2	0.75	0.85	0.95	0.03	0.034	0.038
C	0.08	0.15	0.23	0.003	0.006	0.009
D	2.9	3	3.1	0.114	0.118	0.122
D1	0.75	1.63	2.5	0.03	0.064	0.098
E	4.8	4.9	5	0.189	0.193	0.197
E1	2.9	3	3.1	0.114	0.118	0.122
E2	0.75	1.63	2.5	0.03	0.064	0.098
L	0.4	0.6	0.8	0.016	0.024	0.031
b	0.22	0.3	0.38	0.009	0.012	0.015
e	0.65 BSC			0.026 BSC		
y	-	-	0.1	-	-	0.004
θ	0°	-	8°	0°	-	8°

JEDEC outline: MO-187 AA-T



ESOP-8

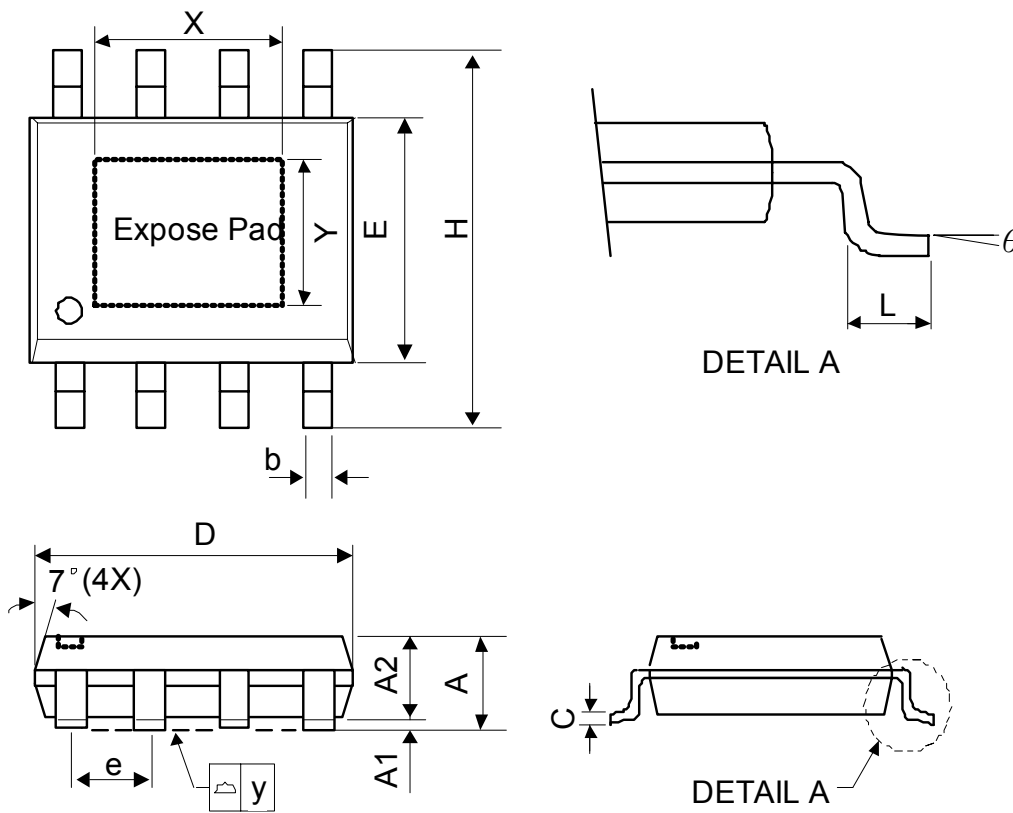

Symbol	Dimensions in Millimeters			Dimensions in Inches		
	Min.	Nom.	Max.	Min.	Nom.	Max.
A	-	-	1.75	-	-	0.069
A1	0	-	0.15	0	-	0.06
A2	1.25	-	-	0.049	-	-
C	0.1	0.2	0.25	0.0075	0.008	0.01
D	4.7	4.9	5.1	0.185	0.193	0.2
E	3.7	3.9	4.1	0.146	0.154	0.161
H	5.8	6	6.2	0.228	0.236	0.244
L	0.4	-	1.27	0.015	-	0.05
b	0.31	0.41	0.51	0.012	0.016	0.02
e	1.27 BSC			0.050 BSC		
y	-	-	0.1	-	-	0.004
X	-	2.34	-	-	0.092	-
Y	-	2.34	-	-	0.092	-
θ	0°	-	8°	0°	-	8°

Mold flash shall not exceed 0.25mm per side
JEDEC outline: MS-012 BA



TDFN 3x3-10L

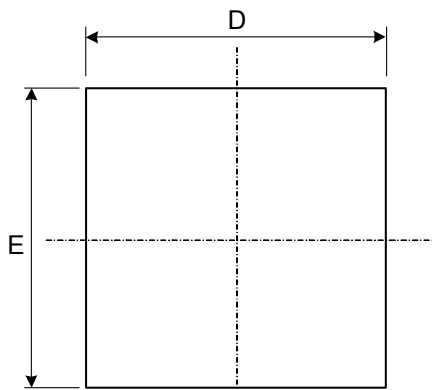

(Top View)

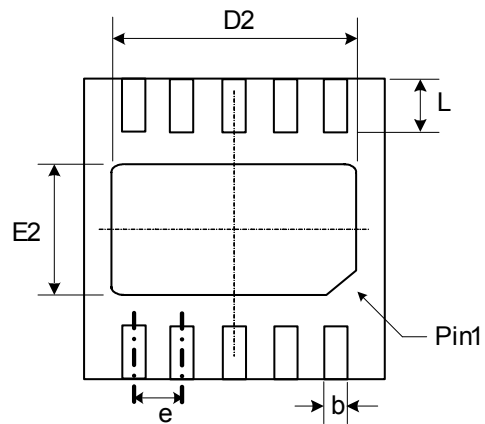

(Bottom View)

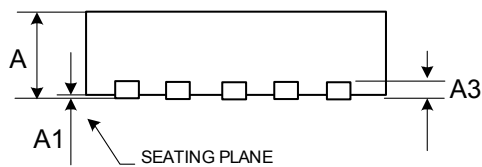

(SIDE View)

Symbol	Dimensions in Millimeters			Dimensions in Inches		
	Min.	Nom.	Max.	Min.	Nom.	Max.
A	0.70	0.75	0.80	0.028	0.030	0.031
A1	0.00	0.02	0.05	0.000	0.001	0.002
A3	0.20 REF.			0.008 REF.		
b	0.18	0.25	0.30	0.007	0.010	0.012
D	2.90	3.00	3.10	0.114	0.118	0.122
D2	2.20	2.40	2.50	0.087	0.094	0.098
E	2.90	3.00	3.10	0.114	0.118	0.122
E2	1.50	1.60	1.70	0.059	0.063	0.070
e	0.50 BSC.			0.020 BSC.		
L	0.30	0.40	0.50	0.012	0.016	0.020