

HA17358A Series

Dual Operational Amplifier

HITACHI

ADE-204-033B (Z)

Rev.2
May 2001

Description

HA17358A series are dual operational amplifier that provide high gain and internal phase compensation, with single power supply. They can be widely applied to control equipments and to general use.

Features

- Wide range of supply voltage, and single power supply used
- Wide range of common mode voltage, and possible to operate with an input about 0 V, and output around 0 V is available
- Frequency characteristics and input bias current are temperature compensated
- Low electro-magnetic susceptibility level

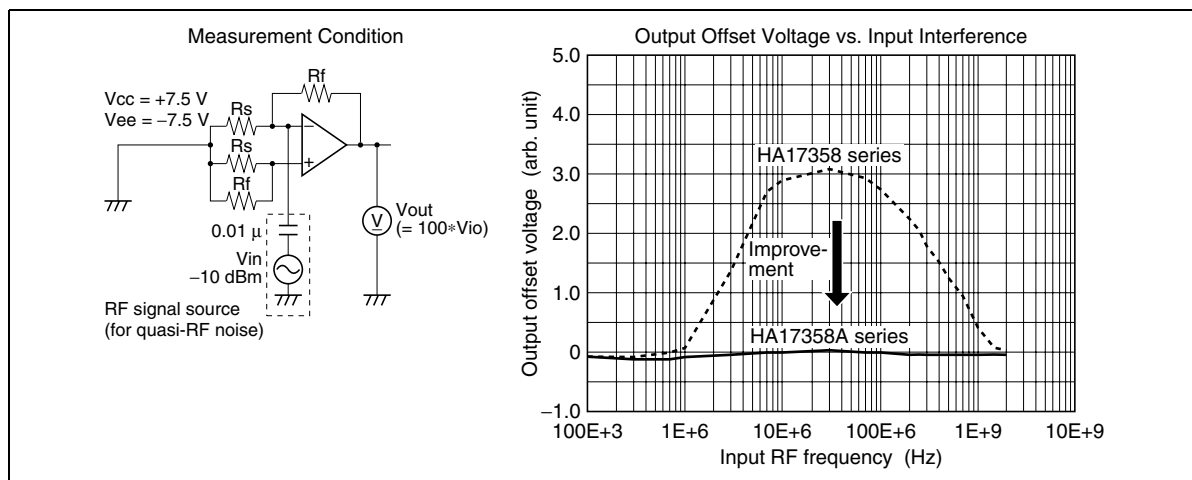

HA17358A Series

Ordering Information

Type No.	Application	Package
HA17358A	Commercial use	DP-8B
HA17358AF		FP-8D
HA17358ARP		FP-8DC

Pin Arrangement

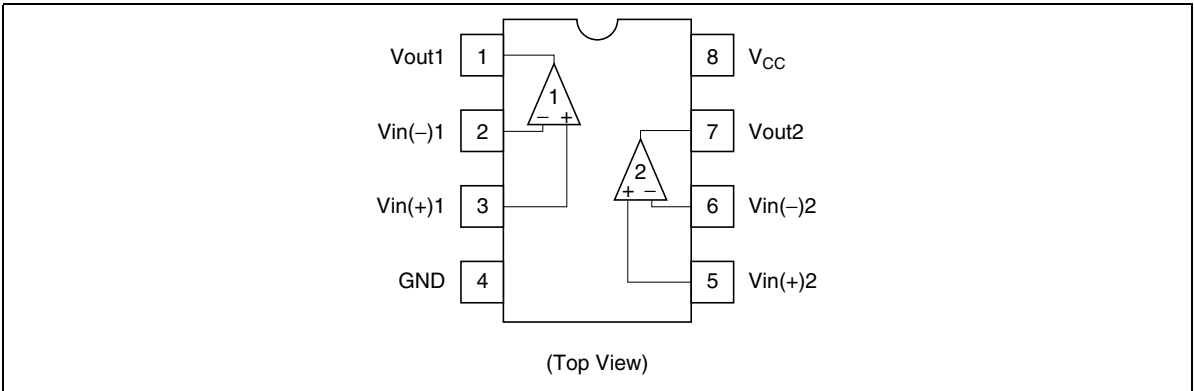

Circuit Schematic (1/2)

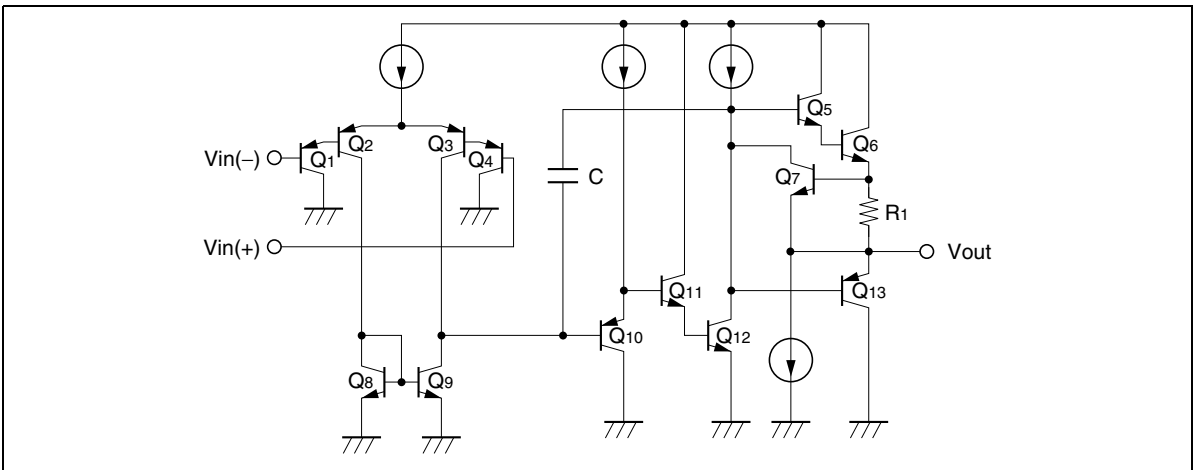

Absolute Maximum Ratings

(Ta = 25°C)

Item	Symbol	Ratings		Unit
		HA17358A	HA17358AF/ARP	
Supply voltage	V _{CC}	32	32	V
Sink current	I _{sink}	50	50	mA
Power dissipation	P _T	570 * ¹	385 * ²	mW
Common mode input voltage	V _{CM}	-0.3 to V _{CC}	-0.3 to V _{CC}	V
Differential input voltage	V _{in} (diff)	±V _{CC}	±V _{CC}	V
Operating temperature	T _{opr}	-40 to +85	-40 to +85	°C
Storage temperature	T _{stg}	-55 to +125	-55 to +125	°C

Notes: 1. This is the allowable values up to Ta = 50°C. Derate by 8.3 mW/°C.

2. These are the allowable values up to Ta = 25°C mounting in air.

When it is mounted on glass epoxy board of 40 mm × 40 mm × 1.5 mmt with 30% wiring density, the allowable value is 570 mW up to Ta = 45°C. If Ta > 45°C, derate by 7.14 mW/°C.

Electrical Characteristics

($V_{CC} = +15\text{ V}$, $T_a = 25^\circ\text{C}$)

Item	Symbol	Min	Typ	Max	Unit	Test Conditions
Input offset voltage	V_{IO}	—	3	7	mV	$V_{CM} = 7.5\text{V}$, $R_S = 50\Omega$, $R_f = 50\text{k}\Omega$
Input offset current	I_{IO}	—	5	50	nA	$V_{CM} = 7.5\text{V}$, $I_{IO} = I_{I(+)} - I_{I(-)} $
Input bias current	I_{IB}	—	30	250	nA	$V_{CM} = 7.5\text{V}$
Power source rejection ratio	PSRR	—	93	—	dB	$R_S = 1\text{k}\Omega$, $R_f = 100\text{k}\Omega$
Voltage gain	A_{VD}	75	90	—	dB	$R_L = \infty$, $R_S = 1\text{k}\Omega$, $R_f = 100\text{k}\Omega$
Common mode rejection ratio	CMR	—	80	—	dB	$R_S = 50\Omega$, $R_f = 5\text{k}\Omega$
Common mode input voltage range	$V_{CM(+)}$	13.5	—	—	V	$R_S = 1\text{k}\Omega$, $R_f = 100\text{k}\Omega$
	$V_{CM(-)}$	—	—	-0.3	V	$R_S = 1\text{k}\Omega$, $R_f = 100\text{k}\Omega$
Peak-to-peak output voltage	V_{op-p}	—	13.6	—	V	$f = 100\text{Hz}$, $R_L = 20\text{k}\Omega$, $R_S = 1\text{k}\Omega$, $R_f = 100\text{k}\Omega$
Output source current	$I_{osource}$	20	40	—	mA	$V_{IN}^+ = 1\text{V}$, $V_{IN}^- = 0\text{V}$, $V_{OH} = 10\text{V}$
Output sink current	I_{osink}	10	20	—	mA	$V_{IN}^- = 1\text{V}$, $V_{IN}^+ = 0\text{V}$, $V_{OL} = 2.5\text{V}$
Output sink current	I_{osink}	15	50	—	μA	$V_{IN}^- = 1\text{V}$, $V_{IN}^+ = 0\text{V}$, $V_{out} = 200\text{mV}$
Supply current	I_{CC}	—	0.8	2	mA	$V_{IN} = \text{GND}$, $R_L = \infty$
Slew rate	SR	—	0.2	—	$\text{V}/\mu\text{s}$	$R_L = \infty$, $V_{CM} = 7.5\text{V}$, $f = 1.5\text{kHz}$
Channel separation	CS	—	120	—	dB	$f = 1\text{kHz}$

Characteristic Curves

Output Source Current vs. Ambient Temperature

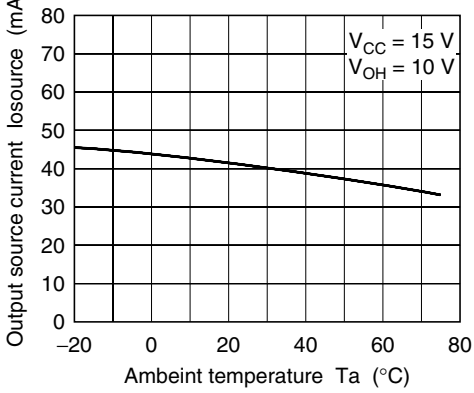

Input Bias Current vs. Ambient Temperature

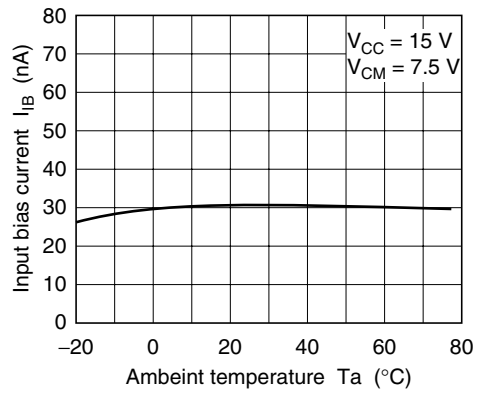

Supply Current vs. Supply Voltage

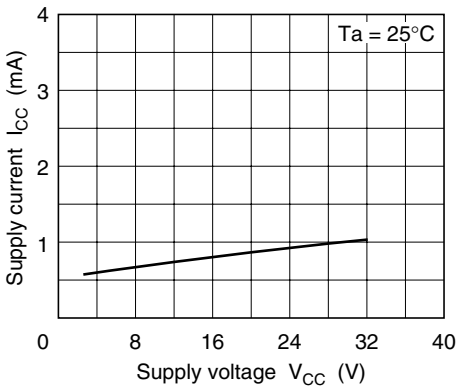

Input Bias Current vs. Supply Voltage

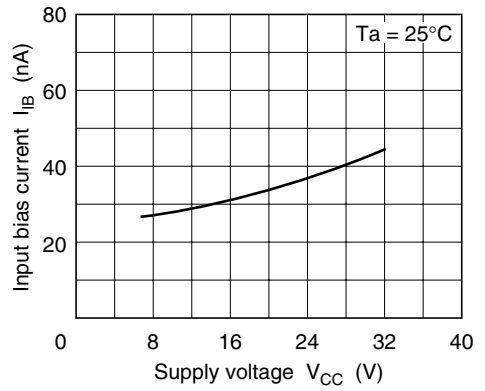

Voltage Gain vs. Supply Voltage

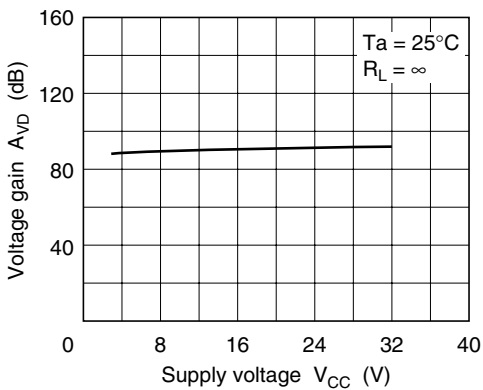

Maximum Output Voltage vs. Frequency

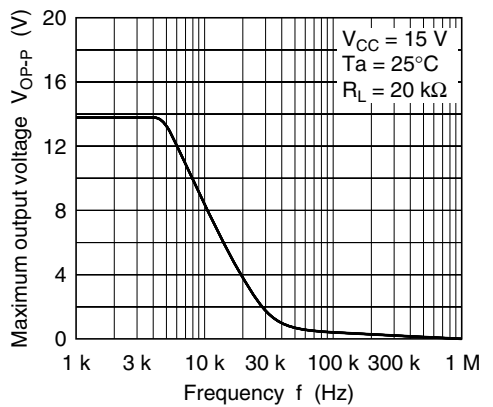

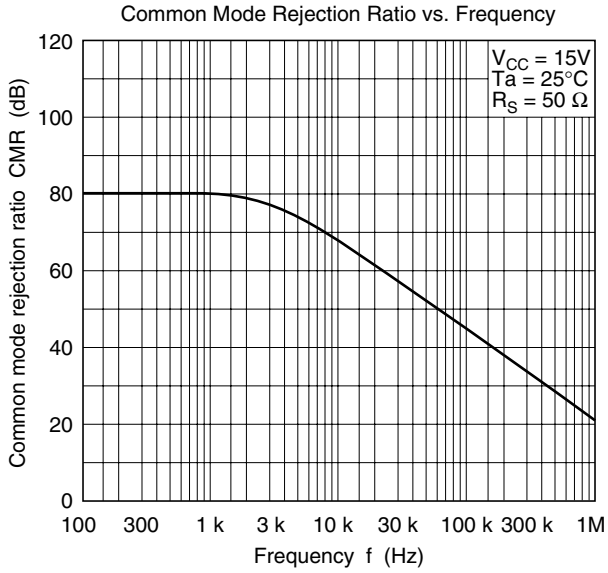
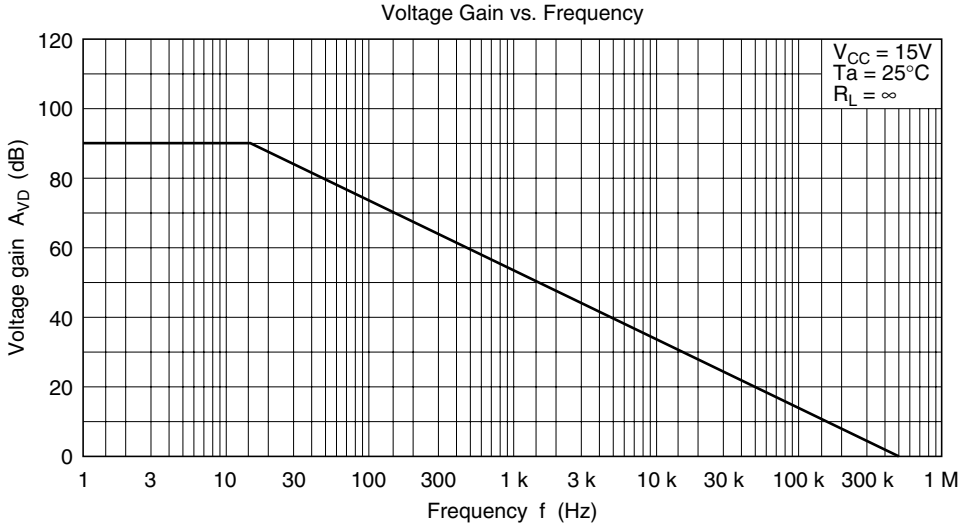

Solder Mounting Method

1. Small and light surface-mount packages require special attentions on solder mounting.
On solder mounting, pre-heating before soldering is needed.
The following figure show an example of infrared rays reflow.
2. The difference of thermal expansion coefficient between mounted substrates and IC leads may cause a failure like solder peeling or solder wet, and electrical characteristics may change by thermal stress.
Therefore, mounting should be done after sufficient confirmation for especially in case of ceramic substrates.

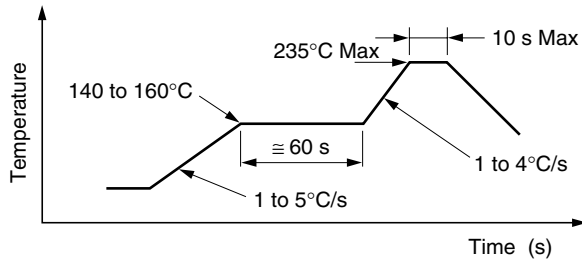
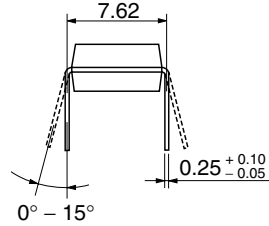
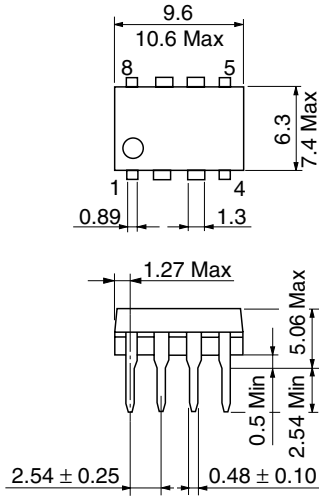

Figure 1 An Example of Infrared Rays Reflow Conditions

Package Dimensions

Unit: mm



Hitachi Code	DP-8B
JEDEC	Conforms
EIAJ	Conforms
Mass (reference value)	0.51 g

Unit: mm

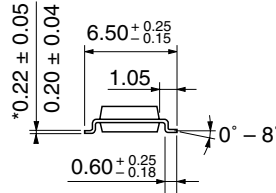
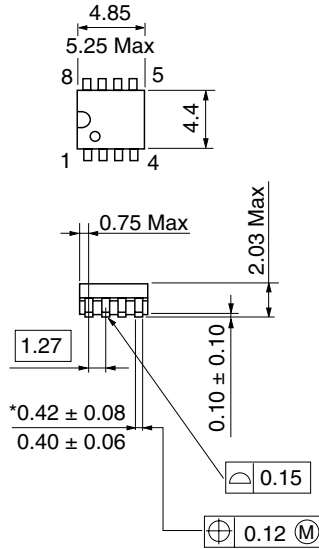

*Dimension including the plating thickness
Base material dimension

Hitachi Code	FP-8D
JEDEC	—
EIAJ	Conforms
Mass (reference value)	0.10 g

Unit: mm

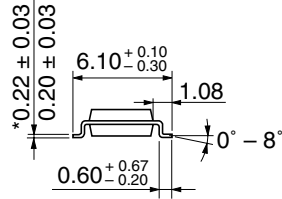
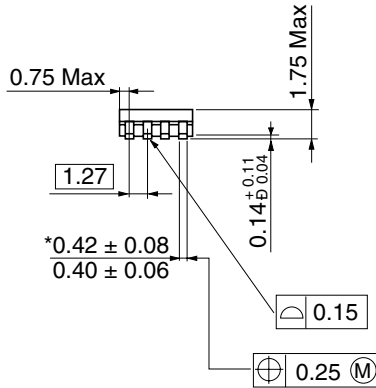
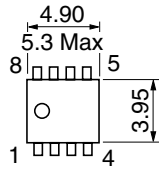

*Dimension including the plating thickness
Base material dimension

Hitachi Code	FP-8DC
JEDEC	Conforms
EIAJ	—
Mass (reference value)	0.085 g

Disclaimer

1. Hitachi neither warrants nor grants licenses of any rights of Hitachi's or any third party's patent, copyright, trademark, or other intellectual property rights for information contained in this document. Hitachi bears no responsibility for problems that may arise with third party's rights, including intellectual property rights, in connection with use of the information contained in this document.
2. Products and product specifications may be subject to change without notice. Confirm that you have received the latest product standards or specifications before final design, purchase or use.
3. Hitachi makes every attempt to ensure that its products are of high quality and reliability. However, contact Hitachi's sales office before using the product in an application that demands especially high quality and reliability or where its failure or malfunction may directly threaten human life or cause risk of bodily injury, such as aerospace, aeronautics, nuclear power, combustion control, transportation, traffic, safety equipment or medical equipment for life support.
4. Design your application so that the product is used within the ranges guaranteed by Hitachi particularly for maximum rating, operating supply voltage range, heat radiation characteristics, installation conditions and other characteristics. Hitachi bears no responsibility for failure or damage when used beyond the guaranteed ranges. Even within the guaranteed ranges, consider normally foreseeable failure rates or failure modes in semiconductor devices and employ systemic measures such as fail-safes, so that the equipment incorporating Hitachi product does not cause bodily injury, fire or other consequential damage due to operation of the Hitachi product.
5. This product is not designed to be radiation resistant.
6. No one is permitted to reproduce or duplicate, in any form, the whole or part of this document without written approval from Hitachi.
7. Contact Hitachi's sales office for any questions regarding this document or Hitachi semiconductor products.

Sales Offices

HITACHI

Hitachi, Ltd.

Semiconductor & Integrated Circuits
Nippon Bldg., 2-6-2, Ohte-machi, Chiyoda-ku, Tokyo 100-0004, Japan
Tel: (03) 3270-2111 Fax: (03) 3270-5109

URL NorthAmerica : <http://semiconductor.hitachi.com/>
 Europe : <http://www.hitachi-eu.com/hel/ecg>
 Asia : <http://sicapac.hitachi-asia.com>
 Japan : <http://www.hitachi.co.jp/Sicd/indx.htm>

For further information write to:

Hitachi Semiconductor (America) Inc. 179 East Tasman Drive San Jose, CA 95134 Tel: <1>(408) 433-1990 Fax: <1>(408) 433-0223	Hitachi Europe Ltd. Electronic Components Group Whitebrook Park Lower Cookham Road Maidenhead Berkshire SL6 8YA, United Kingdom Tel: <44> (1628) 585000 Fax: <44> (1628) 585200
	Hitachi Europe GmbH Electronic Components Group Domacher StraÙe 3 D-85622 Feldkirchen, Munich Germany Tel: <49> (89) 9 9180-0 Fax: <49> (89) 9 29 30 00

Hitachi Asia Ltd.
Hitachi Tower
16 Collyer Quay #20-00
Singapore 049318
Tel : <65>-538-6533/538-8577
Fax : <65>-538-6933/538-3877
URL : <http://www.hitachi.com.sg>

Hitachi Asia Ltd.
(Taipei Branch Office)
4/F, No. 167, Tun Hwa North Road
Hung-Kuo Building
Taipei (105), Taiwan
Tel : <886>-(2)-2718-3666
Fax : <886>-(2)-2718-8180
Telex : 23222 HAS-TP
URL : <http://www.hitachi.com.tw>

Hitachi Asia (Hong Kong) Ltd.
Group III (Electronic Components)
7/F., North Tower
World Finance Centre,
Harbour City, Canton Road
Tsim Sha Tsui, Kowloon
Hong Kong
Tel : <852>-(2)-735-9218
Fax : <852>-(2)-730-0281
URL : <http://semiconductor.hitachi.com.hk>

Copyright © Hitachi, Ltd., 2001. All rights reserved. Printed in Japan.
Colophon 4.0