



BNC Female Connector Clamp/Solder Attachment
 4 Hole Flange For RG58, RG55, RG141, RG142,
 RG223, RG400, .500 inch Threaded Hole Spacing

TECHNICAL DATA SHEET
PE4056
BNC Female Connector Clamp/Solder Attachment 4 Hole Flange For RG58, RG55, RG141, RG142, RG223, RG400, .500 inch Threaded Hole Spacing
Configuration

Connector	BNC Female
Connector Interface Type	RG58, RG55, RG141, RG142, RG223, RG400
Cable Attachment Method (Shield/Contact)	Clamp/Solder
Body Style	Straight
Mount Method	4 Hole Flange

Electrical Specifications

Impedance, Ohms	50
-----------------	----

Mechanical Specifications
Size

Length, in [mm]	1.15 [29.21]
Width/Dia., in [mm]	0.687 [17]
Height, in [mm]	0.687 [17.45]
Weight, lbs [g]	0.041 [18.6]

Connector

Type	BNC Female
Contact Material and Plating	Brass, Gold
Body Material and Plating	Brass, Nickel
Dielectric Type	Teflon

Compliance Certifications (visit www.Pasternack.com for current document)

RoHS Compliant	Yes
----------------	-----

Plotted and Other Data

Notes:	Values at 25 °C, sea level
--------	----------------------------

URL: <http://www.pasternack.com/bnc-female-standard-rg58-rg55-rg141-rg142-rg223-rg400-connector-pe4056-p.aspx>

BNC Female Connector Clamp/Solder Attachment 4 Hole Flange For RG58, RG55, RG141, RG142, RG223, RG400, .500 inch Threaded Hole Spacing from Pasternack Enterprises has same day shipment for domestic and International orders. We maintain 99% availability of the industry's broadest selection of RF, microwave and fiber optic products.

The information contained in this document is accurate to the best of our knowledge and representative of the part described herein. It may be necessary to make modifications to the part and/or the documentation of the part, in order to implement improvements. Pasternack reserves the right to make such changes as required. Unless otherwise stated, all specifications are nominal.



PE4056 CAD Drawing

BNC Female Connector Clamp/Solder Attachment 4 Hole Flange For RG58, RG55, RG141, RG142, RG223, RG400, .500 inch Threaded Hole Spacing

ASSEMBLY PROCEDURES

1. SLIDE CLAMP NUT (1), WASHER (2) & GASKET (3) OVER CABLE. STRIP CABLE AS SHOWN. DO NOT NICK BRAID WHILE CUTTING JACKET. TAPER END OF BRAID TO PERMIT ASSEMBLY OF BRAID CLAMP (4). SLIDE BRAID CLAMP (4) OVER BRAID & SEAT AGAINST CABLE.

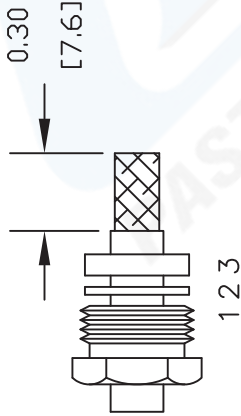

2. FORM BRAID OVER CLAMP NUT (4). TRIM BRAID BACK TO SHOULDER. CUT DIELECTRIC & CENTER CONDUCTOR TO DIMENSION SHOWN. DO NOT NICK CENTER CONDUCTOR. SOLDER CONTACT TO CENTER CONDUCTOR. REMOVE EXCESS SOLDER. DO NOT OVER HEAT DIELECTRIC. INSERT CABLE ASSEMBLY INTO BODY & TIGHTEN.

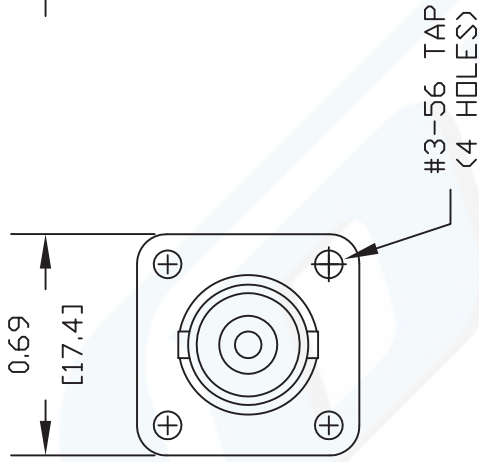
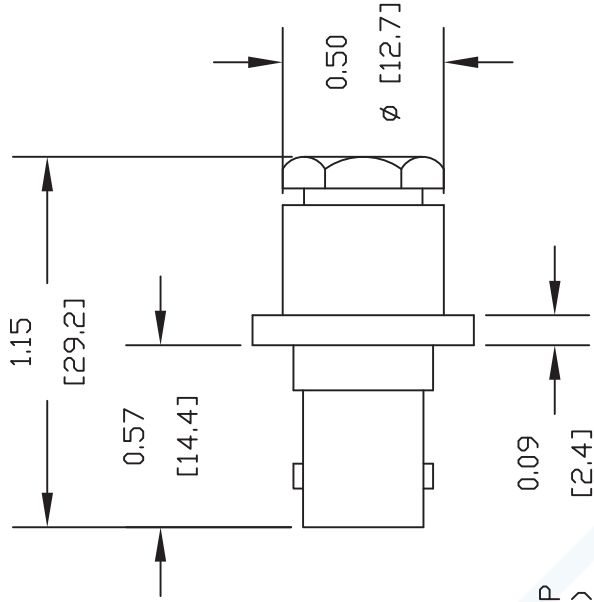
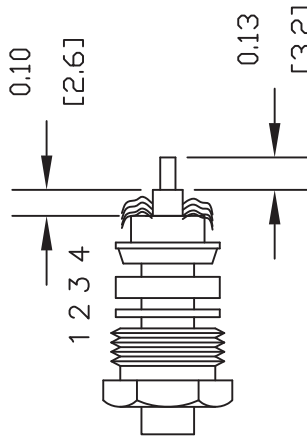

MOUNTING HOLES

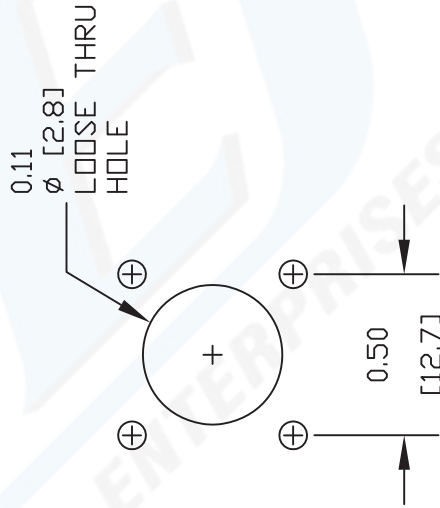

DWG TITLE

PE4056

NOTES:
 1. UNLESS OTHERWISE SPECIFIED ALL DIMENSIONS ARE NOMINAL.
 2. ALL SPECIFICATIONS ARE SUBJECT TO CHANGE WITHOUT NOTICE AT ANY TIME.
 3. DIMENSIONS ARE IN INCHES [mm].
 4. FITS MIL-C-17 AND EQUIVALENT CABLES.

PASTERNAK
 Pasternack Enterprises, Inc.
 P.O. Box 16759 | Irvine | CA | 92623
 Phone: (949) 261-1920 | Fax: (949) 261-7451
 Website: www.pasternack.com | E-Mail: sales@pasternack.com

REV. A FSCM NO. 53919

CAD FILE 081111

SCALE N/A

SIZE A

2231