

High power resistor in a aluminium housing

铝外壳高功率电阻器

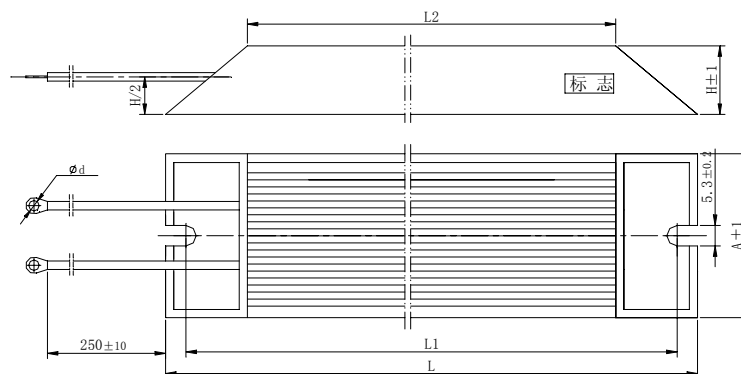

RXLG-H-F



Type 类别		RXLG-H-F 80W	RXLG-H-F 100W	RXLG-H-F 150W(160W)	RXLG-H-F 200W	RXLG-H-F 300W
Resistance range 电阻范围	Ω	R50- 4K3	R75- 5K1	R75- 6K8	1R0- 7K5	1R0- 8K2
Tolerance of resistance 电阻值公差	%	R≥1Ω ±5% R<1Ω ±10%				
Temperature coefficient 温度系数	ppm/ °C	R>20Ω, ±260 ppm/°C R≤20Ω, ±400 ppm/°C				
Insulation resistance 绝缘电阻	MΩ	R≥100				
Weight 重量	kg	-	-	-	-	-
Dimension 尺寸	L	140	160	215	165	215
	L1	125	150	200	150	200
	L2	100	125	175	125	175
	A	40	40	40	60	60
	H	20	20	20	30	30
	d	按客户要求选配				
Power rating 额定电压	V	$\sqrt{P \cdot R}$				
Protection lever 防护等级	-	IP54				
Climatic category (IEC 68-1) 环境类别	-	40/155/21				
Temperature change 使用温度	°C	-40—200				
Ability to tractive power of terminals 端子强度	N	100				
Connections 连接件		Lead fetched out 引出导线				

High power resistor in a aluminium housing

铝外壳高功率电阻器



RXLG-H-T

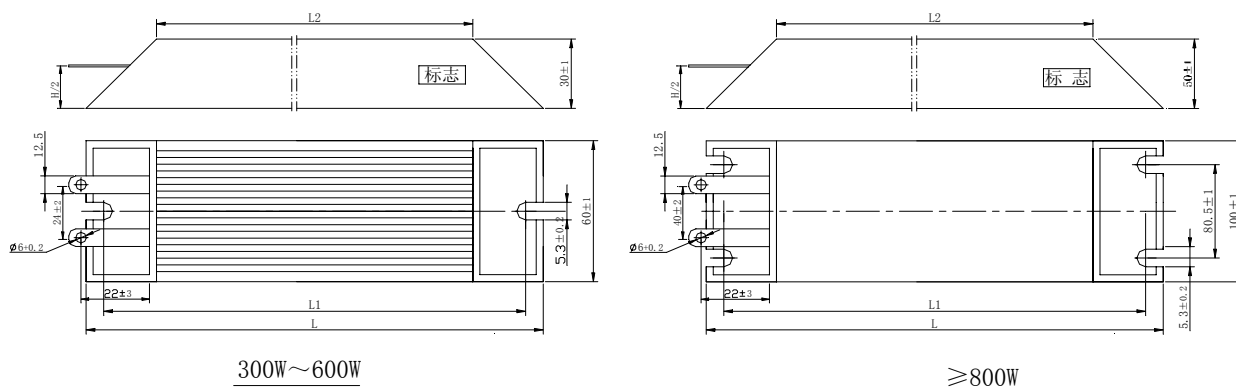

Type 类别		RXLG-H-T 400W	RXLG-H-T 600W	RXLG-H-T 800W	RXLG-H-T 1000W	RXLG-H-T 1200W
Resistance range 电阻范围	Ω	2R2- 10K	4R3- 20K	5R1- 33K	5R1- 43K	6R8- 68K
Tolerance of resistance 电阻值公差	%	$R \geq 1\Omega \pm 5\%$ $R < 1\Omega \pm 10\%$				
Temperature coefficient 温度系数	ppm/ °C	$R > 20\Omega, \pm 260 \text{ ppm}/^\circ\text{C}$ $R \leq 20\Omega, \pm 400 \text{ ppm}/^\circ\text{C}$				
Insulation resistance 绝缘电阻	MΩ	$R \geq 100$				
Weight 重量	kg	-	-	-	-	-
Dimension 尺寸	L	265	400	340	400	460
	L1	250	385	325	385	445
	L2	225	360	300	360	420
Power rating 额定电压	V	$\sqrt{P \cdot R}$				
Protection lever 防护等级	-	IP54				
Climatic category (IEC 68-1) 环境类别	-	40/155/21				
Temperature change 使用温度	°C	-40—200				
Ability to tractive power of terminals 端子强度	N	100				
Connections 连接件		Terminal 焊片				

High power resistor in a aluminium housing

铝外壳高功率电阻器



RXLG-V-F

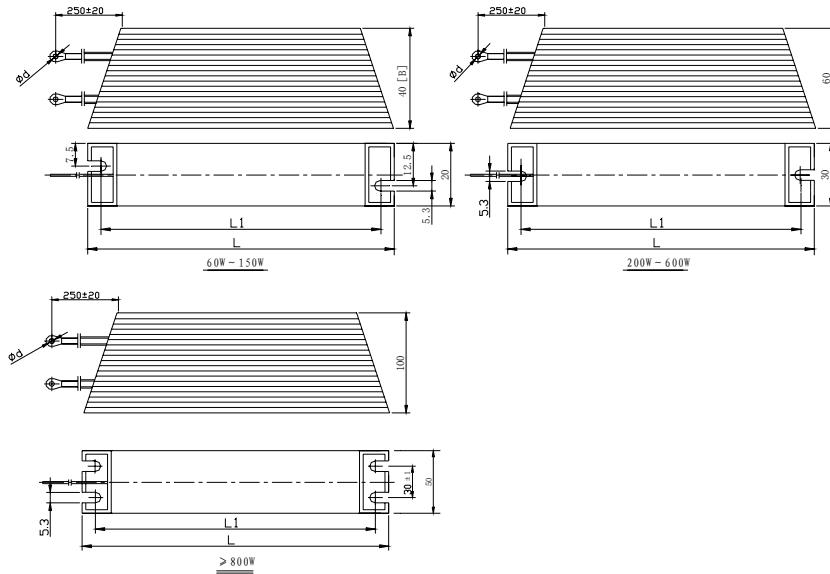

Type 类别		RXLG-V-F 80W	RXLG-V-F 100W	RXLG-V-F 150W(160W)	RXLG-V-F 200W	RXLG-V-F 300W
Resistance range 电阻范围	Ω	R47- 2.7K	R75- 3K	1R0- 5.1K	1R0- 7K5	1R6- 7.5K
Tolerance of resistance 电阻值公差	%	R≥1Ω ±5% R<1Ω ±10%				
Temperature coefficient 温度系数	ppm/ °C	R>20Ω, ±260 ppm/°C R≤20Ω, ±400 ppm/°C				
Insulation resistance 绝缘电阻	MΩ	R≥100				
Weight 重量	kg	-	-	-	-	-
Dimension 尺寸	L	140	160	215	165	215
	L1	125	150	200	150	200
	L2	100	125	175	125	175
	d	按客户要求选配				
Power rating 额定电压	V	$\sqrt{P \cdot R}$				
Protection lever 防护等级	-	IP54				
Climatic category (IEC 68-1) 环境类别	-	40/155/21				
Temperature change 使用温度	°C	-40—200				
Ability to tractive power of terminals 端子强度	N	100				
Connections 连接件		Lead fetched out 引出导线				

High power resistor in a aluminium housing

铝外壳高功率电阻器



RXLG-V-T

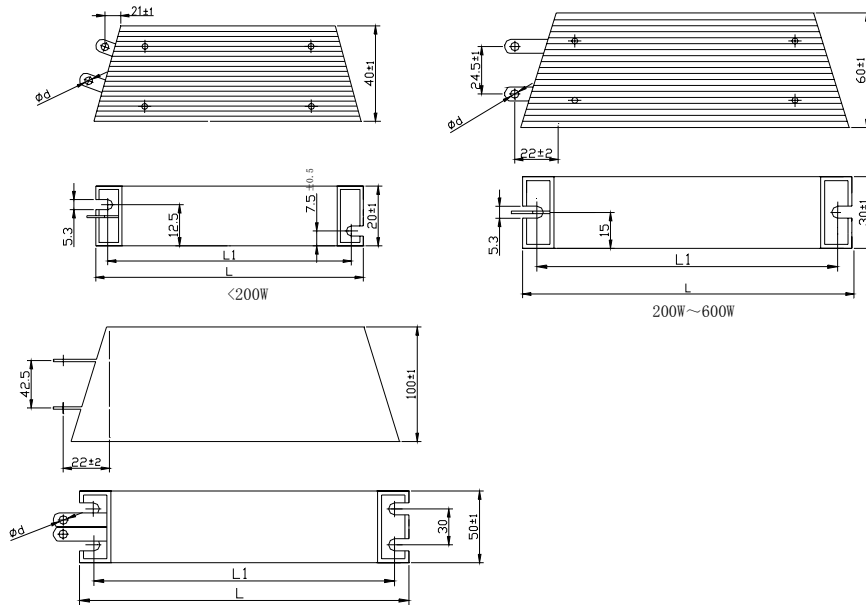

Type 类别		RXLG-V-T 400W	RXLG-V-T 600W	RXLG-V-T 800W	RXLG-V-T 1000W	RXLG-V-T 1200W
Resistance range 电阻范围	Ω	2R2- 10K	4R3- 20K	5R1- 36K	5R1- 43K	6R8- 51K
Tolerance of resistance 电阻值公差	%	$R \geq 1\Omega \pm 5\%$ $R < 1\Omega \pm 10\%$				
Temperature coefficient 温度系数	ppm/ °C	$R > 20\Omega, \pm 260 \text{ ppm}/^\circ\text{C}$ $R \leq 20\Omega, \pm 400 \text{ ppm}/^\circ\text{C}$				
Insulation resistance 绝缘电阻	MΩ	$R \geq 100$				
Weight 重量	kg	-	-	-	-	-
Dimension 尺寸	L	265	400	340	400	460
	L1	250	385	325	385	445
	L2	225	360	300	360	420
	d					
Power rating 额定电压	V	$\sqrt{P \cdot R}$				
Protection lever 防护等级	-	IP54				
Climatic category (IEC 68-1) 环境类别	-	40/155/21				
Temperature change 使用温度	°C	-40—200				
Ability to tractive power of terminals 端子强度	N	100				
Connections 连接件		Terminal 焊片				

Technology parameter of type RXLG aluminous crust resistor

RXLG 铝外壳电阻器技术参数



1. Electric and mechanical capability:

电气、机械性能:

Serial number 序号	Item 测试项目	Capability require 性能	Test method 测试方法
1	Resistance and resistance variance 电阻值以及变化范围	$R \geq 1\Omega \pm 5\%$ $R < 1\Omega \pm 10\%$	Accordance with JIS-C-5202 5.1 遵守 JIS-C-5202 5.1
2	Resistor temperature Coefficient 温度系数	$R > 20\Omega, \pm 260 \text{ ppm}/^\circ\text{C}$ $R \leq 20\Omega, \pm 400 \text{ ppm}/^\circ\text{C}$	To run within temperature range $-25 \sim 200^\circ\text{C}$, factor shall be in accordance with JIS-C-5202 5.2 在 $-25 \sim 200^\circ\text{C}$ 温度下实验, 遵守 JIS-C-5202 5.2
3	Rating load 额定负载	Superficial temperature $\leq 375^\circ\text{C}$ 表面温度 $\leq 375^\circ\text{C}$	Correctly mounted on $300 \times 300 \times 3\text{mm}$ plate aluminium, accordance with JIS-C-5202 5.4 放置在 $300 \times 300 \times 3\text{mm}$ 铝板上, 遵守 JIS-C-5202 5.4
4	Short term overload 短时过载	No abnormality $\Delta R \leq \pm (2\%R + 0.05\Omega)$ 无异常 $\Delta R \leq \pm (2\%R + 0.05\Omega)$	Application of 10 times higher than rating power for 5 seconds under the same invironment, accordance with JIS-C-5202 5.5 同样环境下, 10 倍额定功率, 5 秒, 遵守 JIS-C-5202 5.5
5	Insulation resistance 绝缘电阻	No abnormality $R \geq 100\text{M}\Omega$ 无异常 $R \geq 100\text{M}\Omega$	Insulation resistance shall be 100 $\text{M}\Omega$ or more between terminal and case when measured with DC 500V insulation resistance tester, accordance with JIS-C-5202 5.6 直流 500V, 焊片和外壳之间的绝缘电阻要求大于或等于 $100\text{M}\Omega$, 遵守 JIS-C-5202 5.6
6	Withstand voltage 耐压	No abnormality no destroying $\Delta R \leq \pm (0.1\%R + 0.05\Omega)$ 无异常 无破坏 $\Delta R \leq \pm (0.1\%R + 0.05\Omega)$	No abnormality shall be found when AC 2500V applied between terminal and case for 1 min, accordance with JIS-C-5202 5.7 焊片与外壳之间加交流电压 2500V, 1 分钟, 遵守 JIS-C-5202 5.7
7	Terminal strength 焊片强度	No abnormal or Loosing 无异常 无松动	A static load of 100N in the direction of terminal for 30 seconds, accordance to JIS-C-5202 6.1.2(1) 100N 力加在焊片引出方向, 30 秒, 遵守 JIS-C-5202 6.1.2(1)
8	Vibration proof 振动	No abnormal $\Delta R \leq \pm (0.1\%R + 0.05\Omega)$ 无异常 $\Delta R \leq \pm (0.1\%R + 0.05\Omega)$	No mechanical damage shall be observed where vibration applied in a cycle of 10~55HZ 1.5mm wide in the three directions for 1 minute, keeping 2 hours in each direction. Accordance with JIS-C-5202 6.3 10~55 HZ, 1.5mm 振幅, 三个方向, 一个周期 1 分钟。每个方向上持续 2 小时, 无机械损伤, 遵守 JIS-C-5202 6.3

Technology parameter of type RXLG aluminous crust resistor

RXLG 铝外壳电阻器技术参数



2.Endure capability: 耐久性

Serial number 序号	Item 测试项目	Capability require 性能	Test method 测试方法
1	Heat tolerance 耐热性	No colour changed and abnormality except terminal, sign clear 除焊片外, 无颜色明显变化, 标记清晰。	Where the device is heated to 350±5°C with no load for 120±5 minutes , accordance with JIS-C-5202 7. 2 无负载, 加热至 350±5°C, 120±5 分钟, 遵守 JIS-C-5202 7.2
2	Thermal shock 热冲击	No abnormality $\Delta R \leq \pm (2\%R + 0.05\Omega)$ 无异常 $\Delta R \leq \pm (2\%R + 0.05\Omega)$	Apply rating power for 30 minutes, on reaching thermal stability , within 8-12 s expose to -40±2°C for 15+5 minutes, then constant temperature, 2 hours. accordance with JIS-C-5202 7. 3 额定电压 30 分钟, 常温, 8-12 秒放到 -40±2°C 环境下, 15+5 分钟。再在常温下放置 2 小时, 遵守 JIS-C-5202 7.3
3	Moisture resistance life 耐湿性	No damage Sign clear $\Delta R \leq \pm (3\%R + 0.05\Omega)$ Insulation resistance $R \geq 25M\Omega$ 无损伤 标记清晰 $\Delta R \leq \pm (3\%R + 0.05\Omega)$ 绝缘阻值 $R \geq 25M\Omega$	DC voltage of 100V at 40±2°C at relative humidity 90-95% shall be applied for 1 hour, then cycled off for less than 0.5 hours , for 500+24 hours, accordance with JIS-C-5202 7. 5 直流电压 100V, 40±2°C, 相对湿度 90-95%, 60 分钟开, 30 分钟关, 持续 500+24 小时, 遵守 JIS-C-5202 7.5
4	Load life 负载寿命	No damage Sign clear $\Delta R \leq \pm (5\%R + 0.05\Omega)$ 无损伤 标记清晰 $\Delta R \leq \pm (5\%R + 0.05\Omega)$	Correctly mounted on 300×300×3mm plate aluminium, rating DC voltage shall be applied at 20±7°C, 90 minutes on 30 minutes off, then cycled for 500+24 hours, accordance with JIS-C-5202 7. 10 放置在 300×300×3mm 铝板上, 20±7°C, 额定直流电压, 90 分钟开, 30 分钟关, 循环 500+24 小时, 遵守 JIS-C-5202 7.10

更改事项:

短时过载: “10 倍额定电压” 更改为 “10 倍额定功率”

更改事由: 原翻译错误

High power resistor in a aluminium housing

铝外壳高功率电阻器



RXLG-S3

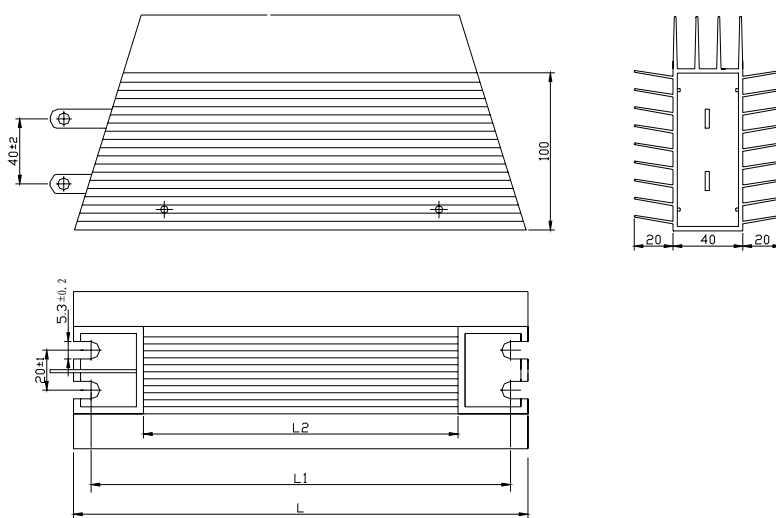

Type 类别		RXLG-S3 800W	RXLG-S3 1000W	RXLG-S3 1200W 沈阳东芝	RXLG-S3 1200W	RXLG-S3 1500W
Resistance range 电阻范围	Ω	5R1- 24K	5R1- 24K	5R1- 1K	5R0- 30K	6R8- 36K
Tolerance of resistance 电阻值公差	%	R≥1Ω ±5% R<1Ω ±10%				
Temperature coefficient 温度系数	ppm/ °C	R>20Ω, ±260 ppm/°C R≤20Ω, ±400 ppm/°C				
Insulation resistance 绝缘电阻	MΩ	R≥100				
Weight 重量	kg	-	-	-	-	-
Dimension 尺寸	L	260	320	320	380	450
	L1	246	306	306	366	436
	L2	208	268	268	328	398
Power rating 额定电压	V	$\sqrt{P \cdot R}$				
Protection lever 防护等级	-	IP54				
Climatic category (IEC 68-1) 环境类别	-	40/155/21				
Temperature change 使用温度	°C	-40—200				

Ability to tractive power of terminals 端子强度	N	100
Connections 连接件		Terminal 焊片

High power resistor in a aluminium housing

铝外壳高功率电阻器



RXLG-S1

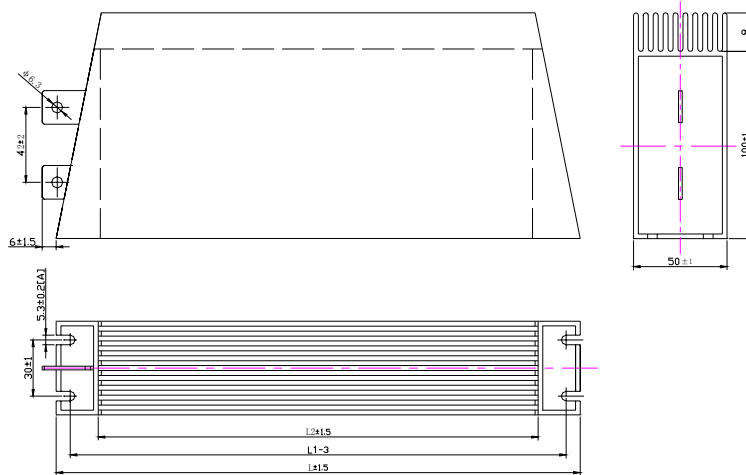

Type 类别		RXLG-S1 1000W	RXLG-S1 1200W	RXLG-S1 1500W	RXLG-S3 2000W	RXLG-S3 2500W	
Resistance range 电阻范围	Ω	1R0- 10K	1R0- 15K	1R0- 24K	1R6- 24K	2R5- 24K	
Tolerance of resistance 电阻值公差	%	R≥1Ω ±5% R<1Ω ±10%					
Temperature coefficient 温度系数	ppm/ °C	R>20Ω, ±260 ppm/°C R≤20Ω, ±400 ppm/°C					
Insulation resistance 绝缘电阻	MΩ	R≥100					
Weight 重量	kg	-	-	-	-	-	
Dimension 尺寸	L	mm	400	460	520	700	800
	L1		385	445	505	685	785
	L2		360	420	480	660	760
Power rating 额定电压	V	$\sqrt{P \cdot R}$					
Protection lever 防护等级	-	IP54					
Climatic category (IEC 68-1) 环境类别	-	40/155/21					
Temperature change 使用温度	°C	-40—200					

Ability to tractive power of terminals 端子强度	N	100
Connections 连接件		Terminal 焊片