

B6TW / B6TY-S04LT / B6TY-S08NF

B6T Workbench

User's Manual



Preface

Thank you for purchasing our touch sensor design kit "B6TWorkbench."

This product supports the design of the touch sensor B6TS series.

To help you use this design kit, this user's manual provides information about the functions, performance and usage of this design kit.

When using this product, be sure to observe the following points:

- Users must have knowledge of electricity and software to use this product.
- Users must thoroughly read and understand this user's manual before using this kit.
- This user's manual must be easily accessible for quick reference.

Warranty, Limitations of Liability

- This product has been developed to support the design of systems using the B6TS series touch sensor. Don't incorporate this product into equipment nor use it for other purposes than that for which it is intended.
- Before setting parameters in B6TS, be sure to fully test and evaluate them for applicability. OMRON never takes responsibility for the results of development by customers.
- This product has been primarily designed for use in laboratories. This product does not meet UL and IEC standards. This should be noted particularly when bringing this product overseas.
- To prevent dangers such as electric shock and fire, and to guarantee product quality, do not repair or modify the product yourself. For repair service, contact our sales representative or special agents.

1. WARRANTY

OMRON's exclusive warranty is that the products are free from defects in materials and workmanship for a period of one year (or other period if specified) from date of sale by OMRON.

OMRON MAKES NO WARRANTY OR REPRESENTATION, EXPRESS OR IMPLIED, REGARDING NON-INFRINGEMENT, MERCHANTABILITY, OR FITNESS FOR PARTICULAR PURPOSE OF THE PRODUCTS. ANY BUYER OR USER ACKNOWLEDGES THAT THE BUYER OR USER ALONE HAS DETERMINED THAT THE PRODUCTS WILL SUITABLY MEET THE REQUIREMENTS OF THEIR INTENDED USE. OMRON DISCLAIMS ALL OTHER WARRANTIES, EXPRESS OR IMPLIED.

2. LIMITATIONS OF LIABILITY

OMRON SHALL NOT BE RESPONSIBLE FOR SPECIAL, INDIRECT, OR CONSEQUENTIAL DAMAGES, LOSS OF PROFITS OR COMMERCIAL LOSS IN ANY WAY CONNECTED WITH THE PRODUCTS, WHETHER SUCH CLAIM IS BASED ON CONTRACT, WARRANTY, NEGLIGENCE, OR STRICT LIABILITY.

In no event shall responsibility of OMRON for any act exceed the individual price of the product on which liability is asserted.

IN NO EVENT SHALL OMRON BE RESPONSIBLE FOR WARRANTY, REPAIR, OR OTHER CLAIMS REGARDING THE PRODUCTS UNLESS OMRON'S ANALYSIS CONFIRMS THAT THE PRODUCTS WERE PROPERLY HANDLED, STORED, INSTALLED, AND MAINTAINED AND NOT SUBJECT TO CONTAMINATION, ABUSE, MISUSE, OR INAPPROPRIATE MODIFICATION OR REPAIR.

OMRON shall not be responsible for the user's programming of a programmable product, or any consequence thereof.

3. SUITABILITY FOR USE

OMRON shall not be responsible for conformity with any standards, codes, or regulations that apply to the combination of products in the customer's application or use of the product.

At the customer's request, OMRON will provide applicable third party certification documents identifying ratings and limitations of use that apply to the products. This information by itself is not sufficient for a complete determination of the suitability of the products in combination with the end product, machine, system, or other application or use.

The following are some examples of applications for which particular attention must be given. This is not intended to be an exhaustive list of all possible uses of the products, nor is it intended to imply that the uses listed may be suitable for the products:

Outdoor use, uses involving potential chemical contamination or electrical interference, or conditions or uses not described in this document.

Nuclear energy control systems, combustion systems, railroad systems, aviation systems, medical equipment, amusement machines, vehicles, safety equipment, and installations subject to separate industry or government regulations.

Systems, machines, and equipment that could present a risk to life or property.

Please know and observe all prohibitions of use applicable to the products.

NEVER USE THE PRODUCTS FOR AN APPLICATION INVOLVING SERIOUS RISK TO LIFE OR PROPERTY WITHOUT ENSURING THAT THE SYSTEM AS A WHOLE HAS BEEN DESIGNED TO ADDRESS THE RISKS, AND THAT THE OMRON PRODUCT IS PROPERLY RATED AND INSTALLED FOR THE INTENDED USE WITHIN THE OVERALL EQUIPMENT OR SYSTEM.

Performance data given in this manual is provided as a guide for the user in determining suitability and does not constitute a warranty. It may represent the result of OMRON's test conditions, and the users must correlate it to actual application requirements. Actual performance is subject to the OMRON Warranty and Limitations of Liability.

This manual discloses technical information only to explain typical operations and applications of this product. This information disclosure for product usage does not mean that the intellectual properties and other properties of OMRON and the associated third party are guaranteed or licensed.

- Microsoft® and Windows® are the registered trademarks of Microsoft Corporation in the United States and other countries.
- IBM is a registered trademark of International Business Machines Corporation.
- The other product names described in this manual are trademarks or registered trademarks of the respective companies.

4. CHANGE IN SPECIFICATIONS

Product specifications and accessories may be changed at any time based on improvements and other reasons.

It is our practice to change model numbers when published ratings or features are changed, or when significant construction changes are made. However, some specifications of the product may be changed without any notice. When in doubt, special model numbers may be assigned to fix or establish key specifications for your application on your request. Please consult with your OMRON representative at any time to confirm actual specifications of purchased product.

Precautions for Correct Use

1. Transportation and Storage

- 1.1 Do not drop or cause an impact to this product because it is a precision machine. Do not throw or let this product fall in order to prevent damage.
- 1.2 Position the package correctly for transportation and storage. Do not place upside down or let stand this product in order to prevent damage by unnatural forces.
- 1.3 Do not use or store this product in places exposed to corrosive gas (hydrogen sulfide) or salty wind, or where it will be subjected to oil/ water spray or direct sunlight

2. Installation

- 2.1 Do not place heavy objects on this product in order to avoid such unnatural forces.
- 2.2 When installing this product, pay attention to the installation position. When placed in a constrained condition, this product may be subjected to great stress in the interface, resulting in contact or relay errors.
- 2.3 When connecting a cable, check the connector direction in advance in order to connect it correctly.
- 2.4 Connect all the cables before turning on the respective units. In addition, don't connect or disconnect the cable while the corresponding unit is being powered up.
- 2.5 Use this product in a safe place where it will not fall and where other objects will not fall on it.

3. Countermeasures against Static Electricity in Handling this Product

Keep the electric facilities, workbench and workers at the same electric potential. Put a conductive mat with a surface resistance of 10k to 10M on the workbench and ground it. It is recommended for workers to check that there is no electric leakage in the electric facility and to ground it using a resistance of approximately 1M for safety. However, be sure to meet the requirements of safety standards regarding human bodies. Be sure to prevent electric leakage in electric equipment in order to ensure the safety of workers.

4. Product Environment

- 4.1 Do not use a voltage exceeding the specified value for each terminal.
- 4.2 The lower limit of the supply voltage varies for each board. When using this product, confirm the supply voltage of the board.
- 4.3 To ensure product performance, use this product in an operating environment under the specified environmental conditions.
- 4.4 Pay special attention not to carelessly touch the current-carrying part.

CONTENTS

1. Overview
2. List of Delivery Components
3. Environmental Conditions for Use
4. Boards
 - 4.1 B6TS I/F Board
 - 4.2 Sample Board
5. Usage
 - 5.1 Setup
 - 5.2 Usage of Software (B6Tworkbench)
 - 5.3 Teaching
6. External Connectors

1. Overview

This product connects the touch sensor IC (B6TS-04LT [4ch type] or B6TS-08NF [8ch type]) to a personal computer in order to set the operation monitoring parameters. (Hereinafter, the touch sensor IC is simply called the B6TS.)

The B6TS is connected to the personal computer via a serial port.

2. List of Delivery Components

Check for the presence of all components. When there are missing components, please contact our sales representative.

<i>Components delivered</i>	<i>Quantity</i>
B6TS I/F Board (B6TW)	1
Serial communication cable (Dsub 9pin cross)	1
CD-ROM	1
Sample board (B6TY-S04LT or B6TY-S08NF)	1 (either board) *
Flat cable	1

* Either of the following sample boards is delivered according to the model of this product.
 B6TY-S04LT (4ch sample board: B6TS-04LT mounted as a touch sensor IC)
 B6TY-S08LT (8ch sample board: B6TS-08NF mounted as a touch sensor IC)

3. Environmental Conditions for Use

3.1 Environmental Conditions

<i>Item</i>	<i>Specification</i>
Temperature	Use: 0 to40 Storage: -15 to50
Humidity	Use: Below 85%RH (no dew condensation or freezing) Storage: Below 85%RH (no dew condensation or freezing)
Ambient gas	There must not be corrosive gas around.

3.2 Operating Environment

<i>Item</i>	<i>Operating Environment</i>
Host computer	IBM PC/AT compatible with Pentium III installed
OS	Windows®2000 or Windows®XP
Memory capacity	64MB or more
Hard disk capacity	20MB or more
Interface	Serial port (COM) 38400bps [for B6TS I/F board connection] * When a personal computer is not equipped with a serial port, use the USB-serial conversion table.
Supply voltage	B6TS I/F Board: 3.0-5.5DVC 4ch sample board (B6TY-S04LT): 3.1-5.5DVC 8ch sample board (B6TY-S08LT): 4.5-5.5DVC * Supply voltage varies between the boards. When using this product, be sure to confirm supply voltage.
Dissipation current	Below 200mA (including the B6TS I/F board and sample board)

4. Boards

4.1 B6TS I/F Board

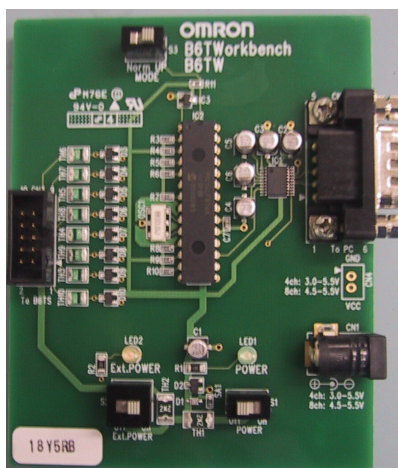

4.1.1 External Specification

<i>Configuration</i>	<i>Circuit symbol</i>	<i>Function</i>
Connector	CN1: Power connector	Connector for power supply to the power connector. For details, refer to the following power specifications.
	CN2: Communication connector	Communication connector for connecting a personal computer port via a serial connection cable.
	CN3: Communication connector	Communication connector for connecting a sample board such as a B6TS chip via a flat cable.
	CN4: Power connector	Power supply connector (not mounted) using the same line as CN1.
Switch	S1: Power supply	Power Switch for power supply from CN1 (or CN4).
	S2: Ext.Power (External power supply)	External power supply switch for connecting the CN3 power line (Vdd) to the power line of the B6TS I/F. When this switch is turned on, the B6TS module (sample board/user system) connection to CN3 is powered or the B6TS I/F board is activated through the B6TS module power supply.
	S3: Maintenance mode	This must be generally set to Norm for maintenance. (The maintenance mode is set at UP and regular operations cannot be performed.)
LED	LED1: Power supply	This LED indicates that the power supply S1 is ON. power is being supplied to this board.
	LED2: Ext.Power External power supply	This LED indicates that the external power supply S2 is ON. When S2 is ON, the voltage line (Vdd) of CN3 is connected to that of the B6TS I/F board.

4.1.2 Power Specification

The B6TS I/F board requires a voltage supply of 3.0 to 5.5VDC.

However, pay attention to supply voltage depending on the touch sensor to be connected.

- When the touch sensor to be connected is B6TS-08NF:
Because the operating voltage of B6TS-08NF is 4.5 to 5.5VDC, be sure to use the B6TS I/F board at 4.5 to 5.5VDC.
- When the touch sensor to be connected is B6TS-04LT:
Because the operating voltage of B6TS-04LT is 3.0 to 5.5VDC, be sure to use the B6TS I/F board at 3.0 to 5.5VDC.
(Considering the voltage drop in the internal protection circuit when using the B6TY-S04LT sample board, be sure to use a voltage of 3.1 to 5.5VDC.)

The B6TS I/F board has been designed, considering two main kinds of power supply.

- A. When an external power supply is connected to CN1 (or CN4):
When the sample board is used, i.e., voltage is supplied from the B6TS I/F board to the B6TS chip, connect an adequate external power supply to CN1 (or CN4) and then turn on S1 and S2.
- B. When voltage is supplied from CN3:
When B6TS is operated using the power supply of a user system for monitoring, connect the power line of CN3 to the user system. (For this connection, see 6. External Connector.)
Without connecting an external power supply to CN1 (or CN4), turn off S1 and turn on S2.

4.2 Sample Board

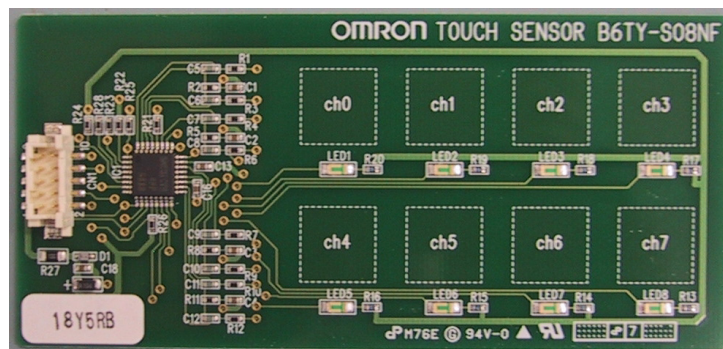

Either of the following sample boards is delivered according to the model of this product.
 B6TY-S04LT (4ch sample board: B6TS-04LT mounted as a touch sensor IC)
 B6TY-S08LT (8ch sample board: B6TS-08NF mounted as a touch sensor IC)

The mounted chips are different but the configurations are identical.

External Specification

<i>Configuration</i>	<i>Circuit symbol</i>	<i>Function</i>
Connector	CN1: Communication connector	Connector for connecting the B6TS I/F board
Touch electrode	Ch0 – Ch3 (or Ch0 –Ch7)	As many touch electrodes as B6TS channels are mounted on the board. The size of a touch electrode is 12 × 12 mm.
LED:	LED1 – LED4 (or LED1-LED8)	LEDs connected to On/Off output terminals (OUTx) from B6TS. Because B6TS uses the On:/Off output and serial communication output, switching the same pin, LED connected to the pin used for serial communication blinks during communication.

5. Usage

5.1 Setup

5.1.1 Setting up Software (B6Tworkbench Software)

- Set the accessory CD-ROM in the CD-ROM drive of the personal computer.
- Execute the installation program stored on the CD-ROM. The installation program varies from chip to chip. Use the installation program corresponding to the chip in use.
 Folder: B6TSetup-English
 B6Tsetup4-eng-v1.0.1.exe --- For B6TS-04LT [4ch type]
 B6Tsetup8-eng-v1.0.1.exe --- For B6TS-08NF [8ch type]

When both chips are used, install both installation programs.

- B6Tworkbench installation starts. After checking the messages displayed on the screen, begin the installation.
 - *1 Software is installed in the following folders.
 C:\Program Files\OMRON\B6Tworkbench4 --- For B6TS-04LT [4ch type]
 C:\Program Files\OMRON\B6Tworkbench8 --- For B6TS-08NF [8ch type]
 - *2 Installation must be performed by those with administrator privileges. Log in as a user with administrator privileges.
 - *3 The Japanese and English versions of the software cannot both be installed at the same time.

5.1.2 Connecting Device

Two connection methods are available depending on the type of usage.
Set up connection A or B depending on the type of usage.

- A. When the power supply is connected to the B6TS I/F board, voltage is supplied from the B6TS I/F board to the B6TS chip.
This method is used when the sample board is used.

1. Connect the personal computer to the CN2 connector of the B6TS I/F board (B6TW) with an accessory serial communication cable.
2. Connect the CN3 connector of the B6TS I/F board to the sample board (or the user system) with an accessory flat cable.
(When the user system and B6TS I/F board are connected, prepare a connection cable.)
3. Supply voltage to the CN1 connector (or CN4) of the B6TS I/F board.
When the sample board is used, supply the following voltage.
8ch sample board (B6TY-S08NF): 4.5 to 5.5DVC
4ch sample board (B6TY-S04LT): 3.1 to 5.5DVC
4. Turn on the switches S1 and S2 in order to supply voltage to the B6TS I/F board and sample board (or the user system).

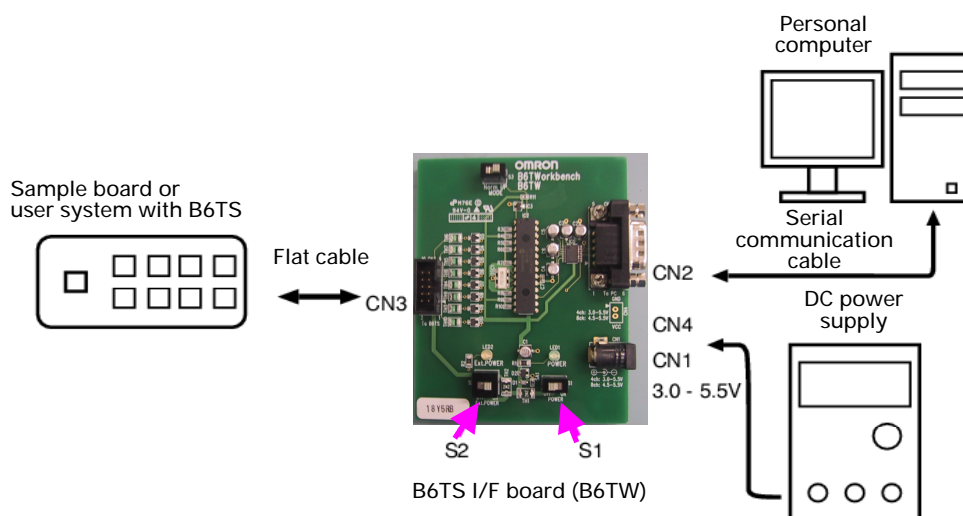

- B. When voltage is supplied from the user system to the B6TS I/F board:
This method is used when the B6TS is operated using the power supply of the user system for status monitoring.

1. Connect the personal computer to the CN2 connector of the B6TS I/F board (B6TW) with an accessory communication cable.
2. Connect the user system B6TS to the CN3 connector of the B6TS I/F board.
(Prepare the connection cable yourself.)
3. Turn on the S2 switch in order to supply voltage from the user system to the B6TS I/F board.

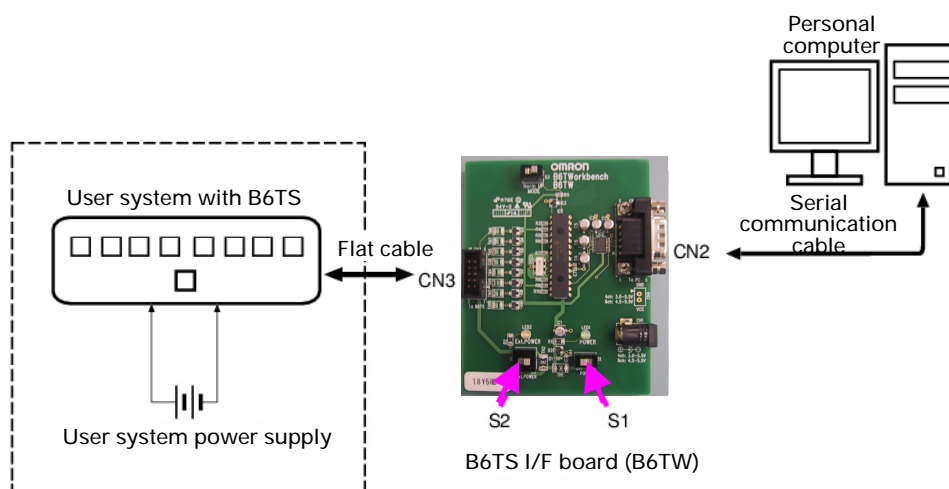

5.2 Using the Software (B6Tworkbench)

5.2.1 Start (Main Menu)

Start B6TWorkbench from the Start menu on the personal computer.
The program to be started varies depending on the chip used.

- When a 4ch chip (B6TS-04LT) or a sample board (B6TY-S04LT) with this chip is used:
[Program] -> [OMRON] -> [B6TWorkbench4] -> [B6TWorkbench4]
- When an 8ch chip (B6TS-08NF) or a sample board (B6TY-S08NF) with this chip is used:
[Program] -> [OMRON] -> [B6TWorkbench8] -> [B6TWorkbench8]

* B6TWorkbench4 and B6TWorkbench8 cannot be started at the same time.

Once the software is activated, the following window appears (main menu).
The following description is given using as an example the B6Tworkbench8 (B6TS-08NF software).
Remember that the number of display channels of B6Tworkbench4 (B6TS-04LT software) is different from that of B6Tworkbench8 (B6TS-08NF software) but the display items are identical to those of B6Tworkbench8.

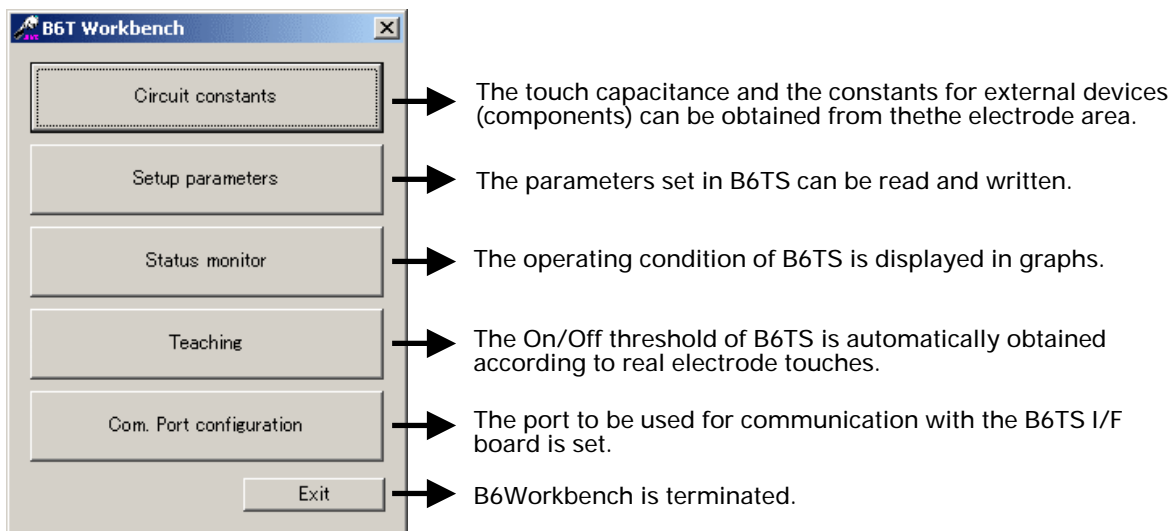

5.2.2 Circuit Constant Calculation

The capacitance can be estimated from the area of an electrode. In addition, the constant and measurement (estimate) of an external circuit component is displayed from the estimated capacitance. Click the "Circuit Constants" button on the main menu. A window appears as shown in the following figure

The following items can be input. A range of input values can be displayed within the window.

- Electrode shape (rectangle or circle) dimensions
- Line length from electrode to B6TS chip(l)
- Electrode surface panel thickness (d) = Distance between electrode at touch and finger
- Surface panel relative permittivity (ϵ_r)

* The values of ϵ_r are about 1 for air, 2 to 4 for plastics (acrylic fiber, etc.) and 3 to 5 for glass.

Input a value and click the "Calculate" button. The estimated value is displayed.

The estimated values of the following items are displayed.

- Estimated capacitance value (non-touch capacitance, difference between touch capacitance and non-touch capacitance)
- Recommended external circuit constant value (value selected from E12 series)
- Estimated B6TS measurement (reference value (REFx) and standard judging change (THRx)) at this time
(REFx indicates a non-touch measurement, THRx indicates a value of two thirds the difference between the touch and non-touch measurements.)

[Notes]

Each display value is an approximate value.

The capacitance significantly varies depending on the ambient metal (distance from wiring pattern, board shape or chassis to electrode). For this reason, remember that external circuit constants need be changed occasionally and B6TS measurements may differ from those described above.

Values listed here are only for reference. Be sure to check whether B6TS measurements (touch and non-touch measurements) are effective on the system of your actual machines.

When the area of an electrode is small and the panel thickness (d) is large, the change between touch and non-touch capacitances may be extremely small. In this case, touch measurement becomes difficult and the message "Estimated capacity variation (ΔC) is too small, it may not detect touch operation." is displayed. Even in this case, the capacitance estimate is displayed. However, the value "0" is displayed as a measurement estimate for the external circuit constant or B6TS.

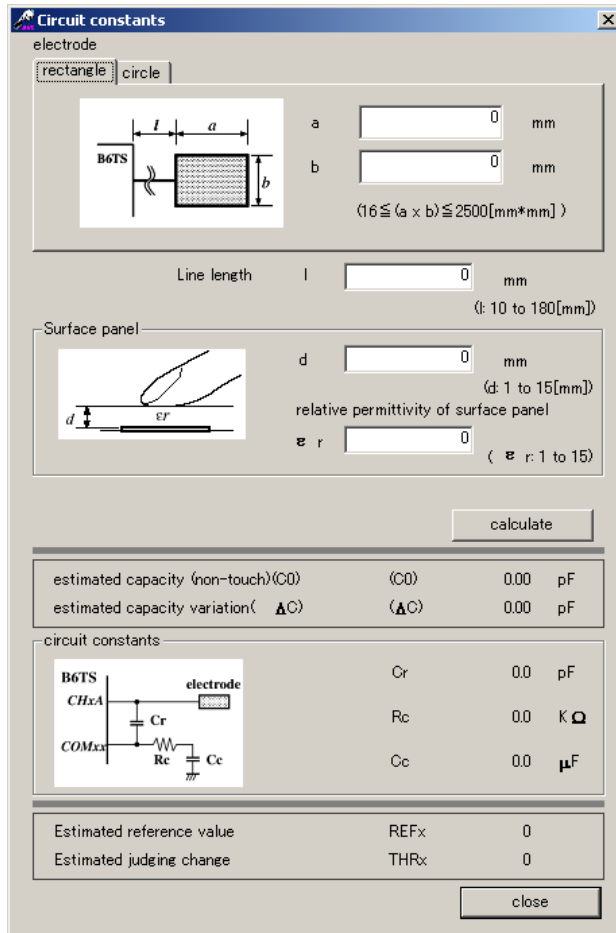

5.2.3 Setting the Communication Port

Set the ports to be used for communication with the B6TS I/F board. Click the "Com. Port configuration" button on the main menu. A window appears as shown in the following figure.

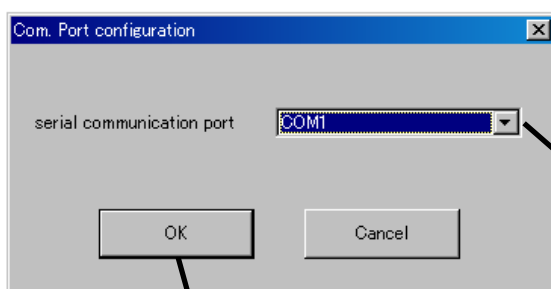

Select a port connected to the B6TS I/F board.

After entering the setting, click the "OK" button.

5.2.4 Reading and Writing the Parameters

The B6TS setup parameters can be read and written via the B6TS I/F board. Click the "Setup Parameters" button on the main menu. A window appears as shown in the following figure.

Click the "Read from B6TS" button at lower left corner of the window to display the current B6TS parameters. When this button is first clicked after this software has been activated, the message "B6Tworkbench is not connected." may be displayed. In this case, click the button again.

When this "Write to B6TS" button is clicked after the necessary items are set, the parameters are written to B6TS.

In addition, the "Write to file" or "Read from file" button can be used to save the current display parameters in a file of the personal computer or to read them from the file.

Device: B6TS-08NF

General settings (MODE)

Output mode (CON)

Serial

On/Off

CHG active (CHG)

Every Measurement

On/Off

Drift Compensation (DC)

Disable

Enable

Teaching measurement count (TCAL)

16 = 512 Times

Judging count (ACD)

2 = 3 Times

Sleep time (SLP)

0 mS

channel	0	1	2	3
Enable (CHEN)/ Latching (TOG)	momentary	momentary	momentary	momentary
Reference value (REFx)	156	132	100	92
Judging change (THR _x)	43	39	39	31
Hysteresis (HYS _x)	9	8	7	10
On judging ratio (RTHR _x)	8	8	9	8
Hysteresis ratio (RHYS _x)	2	2	2	3
On/Off threshold	113	93	61	61

channel	4	5	6	7
Enable (CHEN)/ Latching (TOG)	latching	latching	latching	latching
Reference value (REFx)	124	99	100	106
Judging change (THR _x)	36	30	34	24
Hysteresis (HYS _x)	8	6	7	5
On judging ratio (RTHR _x)	8	8	8	8
Hysteresis ratio (RHYS _x)	2	2	2	2
On/Off threshold	88	69	66	82

Read from B6TS Write to B6TS

Read from file Write to file close

5.2.5 Explanation of Parameters

- General settings (MODE)

- Output Mode (CON)

The output configuration of the B6TS detection results is selected.

Data communication ("serial") using either serial communication (SPI-compliant) or by turning the terminal On or Off depending on the detection result ("On/Off") can be selected.

- CHG active (CHG)

The B6TS measurement status can be monitored using the CHG signals.

Either turning the CHG terminal on "High" for every measurement ("Every Measurement") or turning it on "High" ("On/Off") for every status change from touch to non-touch and vice versa in any measurement channel can be selected.

- Drift Compensation (DC)

The touch/non-touch measurement result varies depending on ambient conditions.

Whether or not to compensate for the touch/non-touch measurement according to this change can be selected.

When "Disable" is selected, touch/nontouch evaluation takes place using the setting On/Off threshold value.

When "Enable" is selected, the On/Off threshold is compensated dynamically depending on the ambient conditions.

However, note that drift compensation is effective at times without touch assessment. No drift compensation takes place even when "Enable" has been selected so long as "touch" is judged as the measurement result of B6TS.

- **Teaching Measurement Count (TCAL)**

The upper limit of measurement is defined for teaching (from actual touch to On/Off threshold automatic calculation). During teaching, measurement takes place up to the number of times decided by multiplying the value specified here by 32. Because it takes 20 to 100ms for single measurement (note that this value varies depending on the external circuit constant), a touch of about 6 to 30 seconds is required if a value of 10 is specified here. (For details, refer to 5.3 Teaching.)

A value from 0 to 255 can be specified.

When "0" is set for teaching, only the reference value (REFx) is updated. When "1" or any greater value is specified, the reference value (REFx), judging change (THRx) and hysteresis (HYSx) are updated.

- **Judging Count (ACD)**

When a measurement exceeds an On/Off threshold up to the number of times specified here plus 1, "touch" is determined (assessed). For example, if "2" is specified here, "touch" is determined (assessed) only when the measurement exceeds the On/Off value consecutively 3 times.

A value from 0 to 255 can be specified.

- **Sleep time (SLP)**

The time interval from one measurement to another (sleep time) is defined.

A value from 0 to 255 can be specified.

When "1" is specified, the sleep time is about 10mS. When "0" is specified, measurement takes place consecutively.

- **Measurement Enable (CHEN)/Latching (TOG)**

Channel measurement and B6TS-output On/Off signal operations are defined.

[disable] – Channel measurement does not take place.

[momentary] – On output takes place at a touch.

[latching] – On/Off output takes place alternately every touch.

- **Reference Value (REFx)**

The non-touch measurement (approximate) is defined.

For actual setting, use the operation monitor.

- **Judging change (THRx)**

"Touch" is determined (assessed) when a difference between the measurement and the reference value is equal to the value defined here.

Namely,

$$\text{Threshold (On/Off threshold) in non-touch-to-touch status change} = \text{REFx} - \text{THRx}$$

For actual setting, use the operation monitor.

In an environment with relatively low noise, it is desirable for this value to be 50 to 70% of change due to touch.

- **Hysteresis (HYSx)**

The hysteresis value for touch-to-non-touch status change is defined.

$$\text{Threshold for touch-to-non-touch status change} = \text{REFx} - \text{THRx} + \text{HYSx}$$

For actual setting, use the "status monitor".

This value should be appropriate for the change due to noise.

- On Judging Ratio (RTHR_x)

The ratio for On determination change (THR_x) compared to measurement change due to touch during teaching (from actual touch to automatic On/Off threshold calculation) is defined. A value from 0 to 15 can be defined. (For details, refer to 5.3 Teaching.)

Assume that the measurement varies for touch by A during teaching. At this time, the new THR_x to be updated by teaching is obtained using the following expression:

$$\text{Updated result of On Judging change (THR}_x) = A \times (\text{On Judging ratio} + 1) / 16$$

For example, when "10" is set for the On determination ratio, the following result is obtained.

$$\text{Updated result of On Judging change (THR}_x) = A \times (10 + 1) / 16 = 0.69 A \text{ (about 70\% of } A)$$

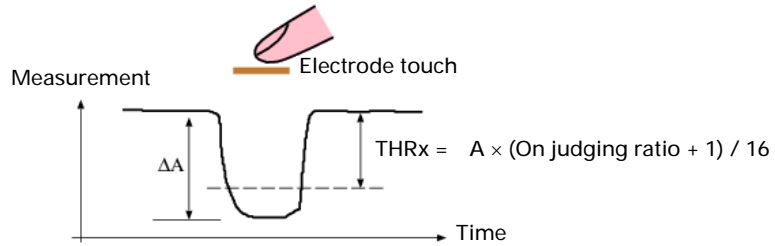

- Hysteresis Ratio (RHYS_x)

As in the On determination ratio, the ratio of hysteresis (HYS_x) compared to measurement change due to touch during teaching is defined. A value from 0 to 15 can be defined. (For details, refer to 5.3 Teaching.)

Assume that the measurement varies for touch by A during teaching. At this time, the new HYS_x to be updated by teaching is obtained using the following expression: (Unlike the On Judging ratio, note that the value is not incremented by one.)

$$\text{Updated result of hysteresis (HYS}_x) = A \times (\text{hysteresis ratio}) / 16$$

For example, when "2" is set for the On Judging ratio, the following result is obtained.

$$\text{Updated result of hysteresis (HYS}_x) = A \times 2 / 16 = 0.13 A \text{ (about 13\% of } A)$$

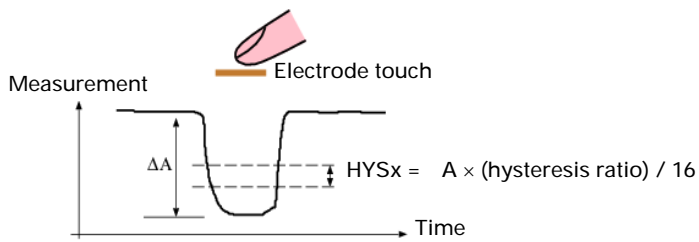

5.2.6 Status Monitor

The measurement state of B6TS can be monitored. Click "Status Monitor" on the main menu. A window appears as shown in the following figure. Click the "Start" button at the lower left corner of the window, and the measurement results of B6TS will be read and displayed in graphs. When the operation monitor is running, B6TS is automatically placed in serial communication mode.

The time interval for reading data from B6TS is set (defined).
 When the time interval is short, there is no time for calculation and measurement update cannot be performed.
 When no measurement update takes place, set a longer time for reading.

Graph display

- Red line – Measurement
- Blue dotted line – Current reference value (=CREFx)
- Green dotted line – Current On/Off threshold (=CREFx - CTHR_x)

The graph is extended, reduced or moved. To center the measurement value in the graph, click the Ⓞ button.

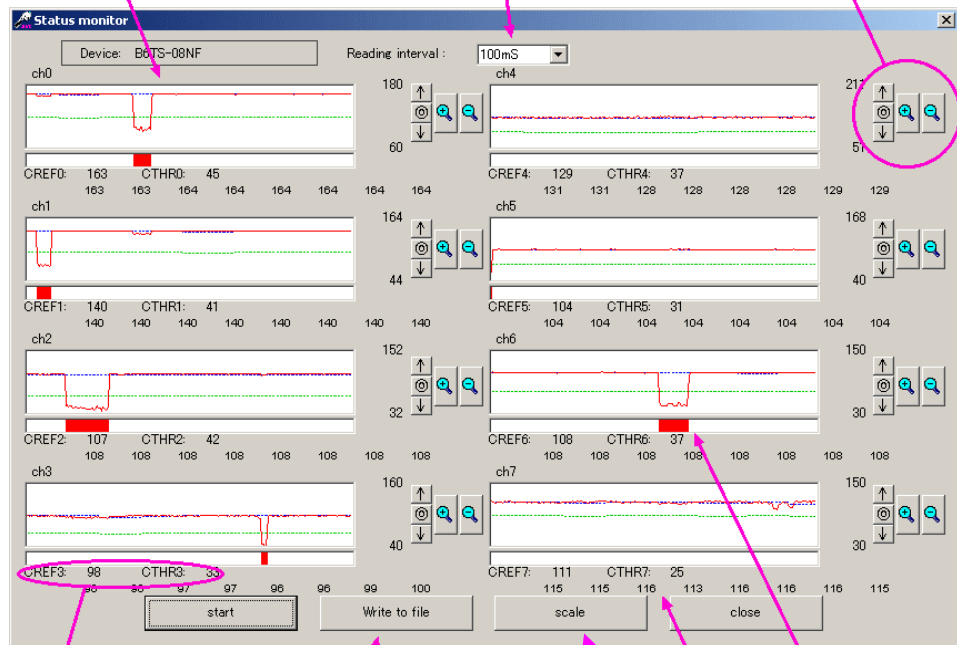

Display data is written to a file. Because this file is created in csv format, data can be read via Excel.

On/Off determination results: When "On" is determined as the result of measurement, a red stripe is displayed.

Current reference value (CREFx)
 The current judging change (CTHR_x) is displayed
 The value is automatically changed during drift compensation.
 For setting without drift compensation, these values are identical to the REF_x and THR_x values of the setup parameter.

Results of the most recent 8 measurements (numeric display)

Scale of Graph display
 The Upper/Lower limit of display scale For each channel is defined.

5.3 Teaching

5.3.1 Overview of Teaching

Parameters such as the On Judging change can be set automatically by actually touching an electrode. This operation is called "Teaching."

Some preparations are required for teaching. The following shows a teaching flow including preparations.

The reference value (REFx), judging change (THRx) and hysteresis (HYSx) are properly updated by teaching and the results are saved in the EEPROM of B6TS. (Hereinafter, these three parameters are called "teaching parameters".)

1. Preparation for teaching: Set the following values in the Setup Parameter window.
Judging change (THRx), hysteresis (HYSx), On judging ratio (RTHRx), hysteresis ratio (RHYSx) and teaching measurement count (TCAL)
For setting, use the operation monitor as necessary.
2. Teaching:
Touch each electrode three times (or more).
3. Confirmation of teaching results:
The results of teaching can be confirmed on the setup parameter window.

The following describes these steps in order.

5.3.2 Preparation for Teaching

For teaching, prepare some parameters in advance. Click the "Setup Parameters" button on the main menu to open the Parameter Setup window.

First, read the current parameters of B6TS by clicking the "Read from B6TS" button, modify their items if necessary, and write them to B6TS by clicking the "Write to B6TS" button.

The following five types of parameters must be specified.

[Notes]

No measurement takes place for channels when the Enable (CHEN)/latching (TOG) parameter has been set to "disable". Accordingly, teaching cannot be performed for these channels. For this reason, it is not necessary to specify the following parameters for channels where "disable" has been set.

- Teaching Measurement Count (TCAL)

The upper limit (count) of teaching is defined. During teaching, measurement takes place up to the number of times defined by multiplying the value specified here by 32. Because it takes 20 to 100ms for single measurement (note that this value varies depending on the external circuit constant), a touch of about 6 to 30 seconds is required if a value of 10 is specified here.

(Hereinafter, this time is called the "teaching measurement time".)

When no touching takes place in a given teaching measurement time after teaching starts, a teaching error is assumed and no parameter update takes place.

However, when this value is 0, only the reference value (REFx) is taught. In this case, no teaching error is assumed because no touch is required.

A value from 0 to 255 can be specified.

- Judging Change (THRx)

The change (approximate value) of measurement at electrode touch is defined.

This parameter must be defined beforehand to differentiate measurement change due to noise (noise change) from change due to electrode touch.

At teaching, "touch" is determined when a detected change is a half of the value defined here. Accordingly, the value defined here may be an approximate value at which the measurement may change at electrode touch.

- Hysteresis (HYSx)

A hysteresis (approximate value) is defined. A value of 0 may be defined here when noise is relatively low.

- On Judging Ratio (RTHRx)

- Hysteresis Ratio (RHYSx)

The ratio of judging change (THRx) or hysteresis (HYSx) compared to measurement change due to touch is defined. A value from 0 to 15 can be defined.

Touch each electrode three times (or more) for teaching.

Next, B6TS internally calculates the minimum value of change for each electrode (minimum change). Assuming that the minimum change is A, the judging change and hysteresis are calculated as followed.

$$\text{Updated result of judging change (THRx)} = A \times (\text{On judging ratio} + 1) / 16$$

$$\text{Updated result of hysteresis (HYSx)} = A \times (\text{hysteresis ratio}) / 16$$

For example, the following expression is derived when the On judging ratio is 10 and hysteresis ratio is 2.

$$\text{Updated result of judging change (THRx)} = A \times (10 + 1) / 16 = 0.69 A \text{ (about 70\% of } A)$$

$$\text{Updated result of hysteresis (HYSx)} = A \times 2 / 16 = 0.13 A \text{ (about 13\% of } A)$$

When noise is relatively low in an environment, the proper value is 7 to 10 for the judging ratio and 1 to 2 for the hysteresis ratio. In this case, the judging change (THRx) is 50 to 70% of A and the hysteresis is 6 to 13% of A.

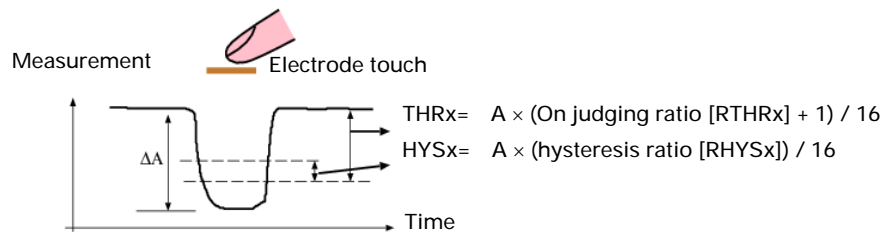

As described above, set the five parameters properly, and then click the "Write to B6TS" button to write them to B6TS.

5.3.3 Execution of Teaching

After setting the parameters, execute teaching. Click the Teaching button on the main menu. The following window appears as shown in the right figure.

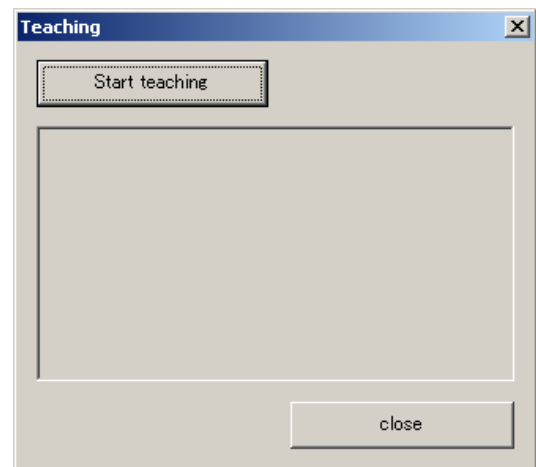

Click the "Start Teaching" button.
After a while, the message
"Please touch each switch more than three times..."
appears as shown in the right figure.
Unless this message appears, don't touch the
electrode.

Once this message appears, touch each electrode.
You may touch the electrodes in any order.
However, it is recommended to change the
electrode touch order as follows to differentiate
one touch from another.

Ch0 → Ch1 → Ch2 → Ch3 → Ch0 → Ch1 → ...

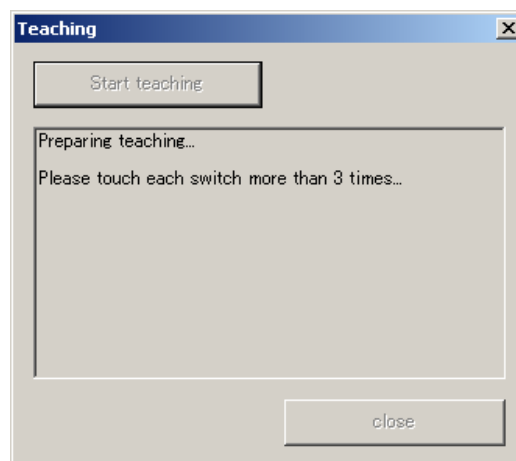

[Notes]

1. The touch time is limited. (For teaching measurement time, see "Teaching Measurement Count" in 5.3.2 "Preparation for Teaching."
When you don't touch each electrode three times or more, a teaching error is assumed and the teaching parameter update does not take place for all channels.
2. When the touch count exceeds the upper limit (number of channels for measurement × 4), further measurement does not take place and teaching terminates. Namely, when all channels are used in B6TS-04LT [for 4ch], teaching terminates when the touch count reaches 16. Similarly, when all channels are used in B6TS-08NF [for 8ch], teaching terminates when the teaching count reaches 32.
3. When there is a channel for which "disable" has been set on the Setup Parameter window, no touch measurement takes place for the channel. Accordingly, teaching cannot be performed for these channels.
Even in this case, when the touch count exceeds the upper limit (number of channels for measurement × 4), further measurement does not take place and teaching terminates. For example, assume that "disable" has been set for a channel in B6TS-04LT [for 4ch]. In this case, teaching terminates when the touch count reaches 12 (3 × 4 =12) because the number of channels for measurement is 3. This is true for B6TS-08NF [for 8ch].

When you touch each electrode three times or more
and the teaching measurement time is over,
the message shown in the right figure appears to
indicate the completion of teaching.

* When the set teaching measurement time is long
(i.e., the teaching measurement count (TCAL) value
is large), you may touch each electrode four times
to terminate teaching.

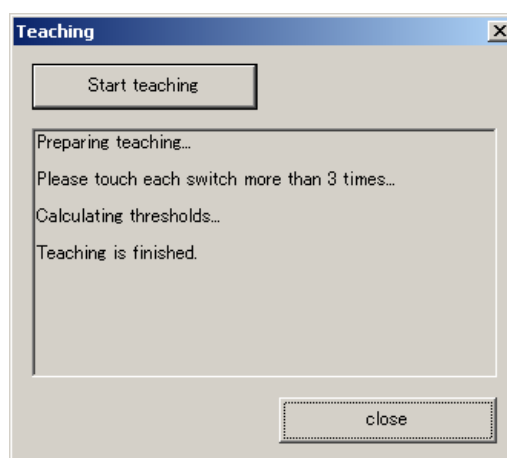

When teaching does not terminate normally
because you didn't touch any electrode within
the given teaching measurement time,
the message shown in the right figure appears.

- When you cannot touch any electrode within
the given teaching measurement time,
specify a larger teaching measurement count
(TCAL) value on the Setup Parameter Definition
window and attempt teaching again.

- If this message appears even when you've
touched each electrode normally, check whether
or not the values for judging change (THR_x) and
hysteresis (HYS_x) are properly set for actual
measurement.

* While the teaching window is open, you cannot
move to other windows such as the Setup Parameter
window and Status Monitor window. In this case,
close the teaching window once, then move to the other window.

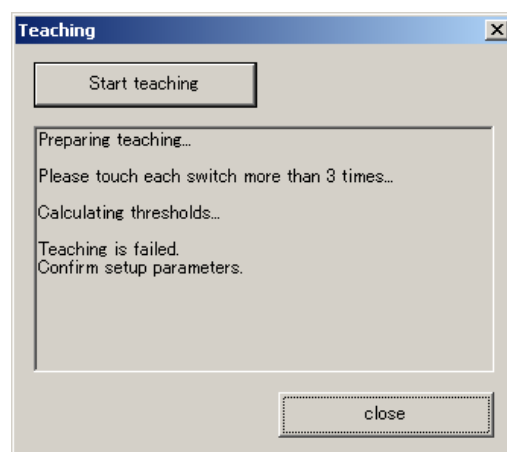

5.3.4 Confirmation of Teaching Results

Once teaching terminates, confirm that the teaching parameters have been set properly on the Setup Parameter window.

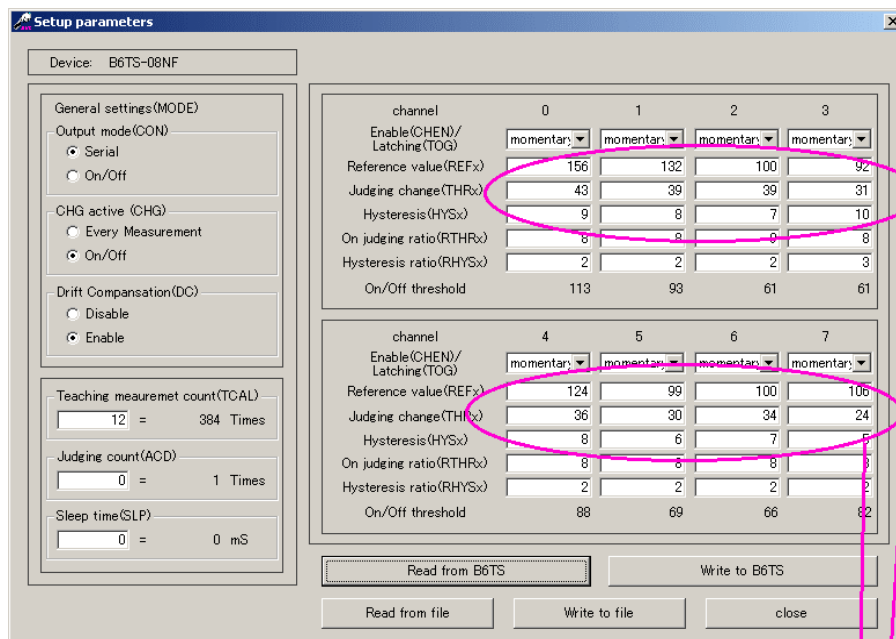

Check whether these three teaching parameters are in a proper range for each channel.

6. External Connectors

6.1 B6TS I/F Board (CN3)

The following table shows the pin assignments of CN3 on the B6TS I/F board. Refer to this table when connecting this I/F board to your design board with a B6TS chip.

Before connecting this board, be very careful to supply voltage and connector direction. When excess voltage is supplied to this B6TS I/F board, it may be damaged.

Reference)

Board connector (CN3): 2.54 mm pitch 10pin connector (straight) Hirose HIF3FC-10PA-254DSA72

Engage connector (cable-side connector): Hirose HIF3BA-10DA-2.54R or the equivalent

1	2
3	4
5	6
7	8
9	10

Pin No.	Signal name	Remarks
1	Vdd	To be connected to the power line of the B6TS I/F board via S2
2	SETUP	
3	MISO	(For B6TS-04LT, no signal connection is required.)
4	MOSI/SD	MOSI must be connected for B6TS-08NF and SD for B6TS-04LT.
5	SCK	
6	SCS	(For B6TS-08NF, no signal connection is required.)
7	MEAS	
8	CHG	
9	RESET	
10	GND	Signal ground

6.2 Sample Board (CN1)

The following table shows the pin assignments of CN1 on this sample board. Refer to this table when connecting this sample board to your design system temporarily for operation check.

Before connecting this board, be very careful to supply voltage and connector direction. When excess voltage is supplied to this sample board, it may be damaged.

Reference)

Board connector (CN1): 2 mm pitch 10pin connector (straight) Hirose DF11G-10DP-2V (50)

Engage connector (cable-side connector): Hirose DF11-10DS-2C

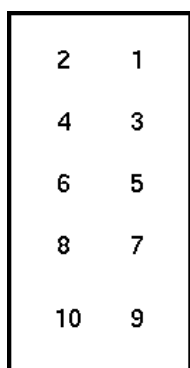

<i>Pin No.</i>	<i>Signal name</i>	<i>Remarks</i>
1	Vdd	Power supply Supply 3.1 to 5.5DVC to B6TY-S04LT [4ch sample board] and 4.5 to 5.5DVC to B6TY-S08NF [8ch sample board].
2	SETUP	
3	MISO	For B6TY-S04LT [4ch sample board], no signal connection is required.
4	MOSI/SD	SD must be connected for B6TY-S04LT [4ch sample board] and MOSI for B6TY-S08NF [8ch sample board].
5	SCK	
6	SCS	For B6TY-S08NF [8ch sample board], no signal connection is required.
7	MEAS	
8	CHG	
9	RESET	
10	GND	Signal ground

OMRON SALES OFFICES North America

OMRON ELECTRONICS LLC
Phone: 1-847-843-7900
OMRON CANADA INC.
Phone: 416-286-6465

Europe

OMRON EUROPE B.V
Phone: 31-23-56-81-300

Asia Pacific

中国
欧姆龍（中国）有限公司
Phone: 86-10-8391-3005
台灣
台灣歐姆龍股 有限公司 總公司
Phone: 886-2-2715-3331
SINGAPORE
OMRON ASIA-PACIFIC PTE LTD.
Phone: 65-6547-6789

香港
歐姆龍亞洲有限公司
Phone: 852-2375-3827
大韓民國
Contron Corporation
Phone: 82-2-3218-5700
AUSTRALIA
OMRON ELECTRONICS PTY.LTD.
Phone: 61-2-9878-6377