

FEATURES

- WOUND METALLIZED POLYPHENYLENE SULFIDE (PPS) FILM
- WIDE TEMPERATURE RANGE UP TO +125°C (with derating above 105°C)
- COMPATIBLE WITH SAC REFLOW SOLDERING (+260°C)
- VERY STABLE TEMPERATURE, FREQUENCY, VOLTAGE, BIAS AND DIELECTRIC ABSORPTION CHARACTERISTICS
- SUITABLE FOR INVERTOR POWER SUPPLIES FOR LCD BACKLIGHTING
- TAPE AND REEL PACKAGING



SPECIFICATIONS	Case Size
	5.7mm x 4.5mm x 2.2mm ~ 10.2mm x 7.2mm x 3.1mm
Capacitance Range	0.01μF ~ 0.22μF
Voltage Ratings	100Vdc (63Vrms up to 40KHz*)
Capacitance Tolerance	±5% (J), ±10% (K)
Temperature Range	-40°C ~ +125°C (voltage derating above +105°C)
Dissipation Factor (20°C)	0.15% max. @ 1KHz, 0.25% max. @ 100KHz
Insulation Resistance (20°C)	15GΩ minimum @ 100Vdc, 60 seconds (thru 2K ohm resistor)
Dielectric Withstanding Voltage	150% of Rated Voltage

RoHS Compliant
includes all homogeneous materials

*See Part Number System for Details

*Note: Vrms should be limited so that surface temperature rise does not exceed +10°C

ENVIRONMENTAL CHARACTERISTICS

Life Test At +125°C 1,000 Hours at 125% of Rated Voltage	Capacitance Change	Within ±3% of Initial Value
	Dissipation Factor	0.25% max. @ 1KHz, 0.35% max. @ 100KHz
	Insulation Resistance	5GΩ minimum @ 100Vdc, 60 seconds
Resistance to Soldering Heat +260°C Peak for 5 Seconds	Capacitance Change	Within ±10% of Initial Value
	Dissipation Factor	0.25% max. @ 1KHz, 0.35% max. @ 100KHz
	Insulation Resistance	10GΩ minimum @ 100Vdc, 60 seconds
Humidity Load Life 500 Hours, +40°C @ 90~95% RH and Rated Voltage	Capacitance Change	Within ±5% of Initial value
	Dissipation Factor	0.35% max. @ 1KHz, 0.45% max. @ 100KHz
	Insulation Resistance	5GΩ minimum @ 100Vdc, 60 seconds
Heat Resistance 125°C for 500 Hours	Capacitance Change	Within ±2% of Initial value
	Dissipation Factor	0.15% max. @ 1KHz, 0.25% max. @ 100KHz
	Insulation Resistance	10GΩ minimum @ 100Vdc, 60 seconds
Solderability with 25% Wt Rosin-Methanol Flux	95% Minimum Coverage After 2~3 Second Dip into 250°C Solder Pot	

TEMPERATURE DERATING OF WORKING VOLTAGE

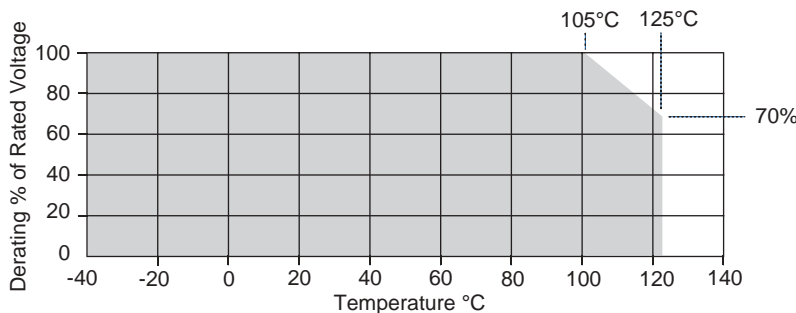

PERMISSIBLE AC VOLTAGE DERATING

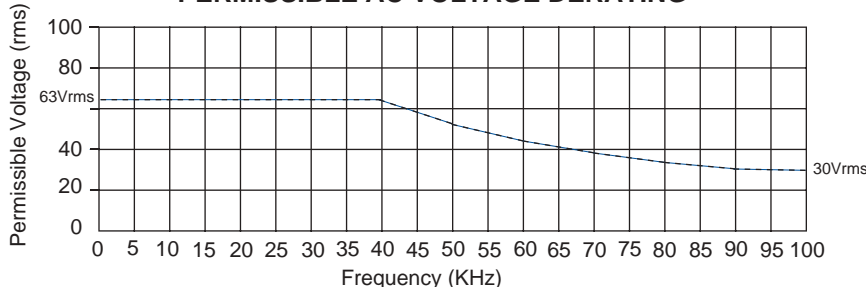

PART NUMBER SYSTEM

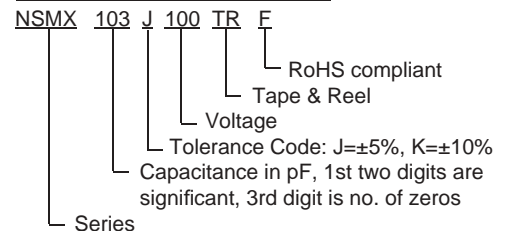

STANDARD PRODUCTS AND CASE DIMENSIONS (mm)

Part Number	Cap. (μF)	Voltage (Vdc)	H ± 0.4	W ± 0.4	L ± 0.3	p min.	b min.
NSMX103_100TRF	0.01	100	2.2	4.5	5.7	0.2	3.0
NSMX123_100TRF	0.012		2.2	4.6	5.7		3.0
NSMX153_100TRF	0.015		2.4	4.8	5.7		3.0
NSMX183_100TRF	0.018		1.7	5.5	7.7		5.0
NSMX223_100TRF	0.022		1.8	5.4	7.7		5.0
NSMX273_100TRF	0.027		2.2	5.9	7.7		5.0
NSMX333_100TRF	0.033		2.4	6.2	7.7		5.0
NSMX393_100TRF	0.039		1.7	5.4	7.7		5.0
NSMX473_100TRF	0.047		1.9	5.6	7.7		5.0
NSMX563_100TRF	0.056		2.1	5.8	7.7		5.0
NSMX683_100TRF	0.068		2.3	6.0	7.7		5.0
NSMX823_100TRF	0.082		2.9	6.0	7.7		5.0
NSMX104_100TRF	0.1		3.0	6.2	7.7		5.0
NSMX124_100TRF	0.12		2.9	6.2	7.7		5.0
NSMX154_100TRF	0.15		3.3	6.6	7.7		5.0
NSMX184_100TRF	0.18		2.8	6.6	10.2		7.5
NSMX224_100TRF	0.22		3.1	7.2	10.2		7.5

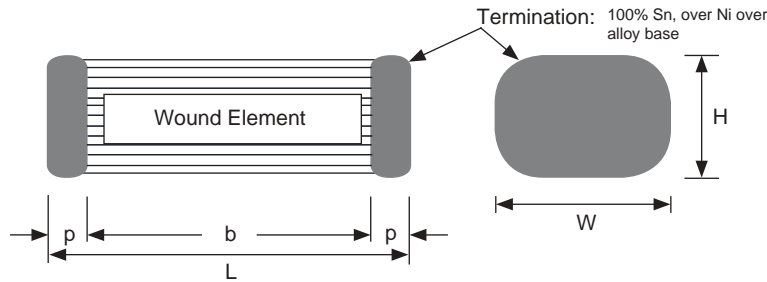

TAPE AND REEL DIMENSIONS (mm) AND REEL QUANTITIES

Part Number	A ±0.3	B ±0.3	W ±0.3	F ±0.1	P1 ±0.1	P2 ±0.1	T ±0.1	T2	D1	Reel Diameter	W	W ₁	Reel Quantity
NSMX103_100TRF	5.0	6.3	12.0	5.5*	8.0	2.0*	0.3	≤3.5	-	330 ± 4.0	14.0 ± 1.5	≤20.5	2,000
NSMX123_100TRF								≤3.0	250 ± 6.0				
NSMX153_100TRF								≤4.0					
NSMX183_100TRF	6.0	8.1	≤3.0	250 ± 6.0									
NSMX223_100TRF			≤3.0		330 ± 4.0								
NSMX273_100TRF	6.6	9.1	≤4.0	330 ± 4.0									
NSMX333_100TRF			≤3.0		250 ± 6.0								
NSMX393_100TRF	6.0	8.1	≤3.0	330 ± 4.0									
NSMX473_100TRF			≤3.0		250 ± 6.0								
NSMX563_100TRF	6.6	9.1	≤4.0	330 ± 4.0									
NSMX683_100TRF			≤4.0		330 ± 4.0								
NSMX823_100TRF	7.4	8.4	≤4.0	330 ± 4.0									
NSMX104_100TRF			≤4.0		330 ± 4.0								
NSMX124_100TRF	7.6	10.6	≤4.5	330 ± 4.0									
NSMX154_100TRF			≤4.5		330 ± 4.0								
NSMX184_100TRF	≤4.5	330 ± 4.0											
NSMX224_100TRF	≤4.5		330 ± 4.0										
													1,000

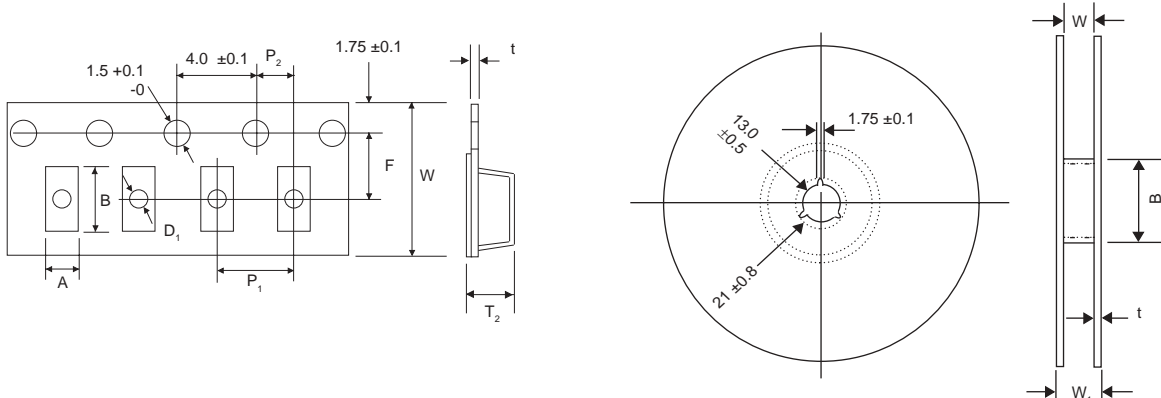

RECOMMENDED LAND PATTERN (mm)

Part Number	A	B	C
NSMX103_100TRF	2.0 ~ 2.5	4.0 ~ 4.5	3.3 ~ 3.7
NSMX123_100TRF			
NSMX153_100TRF			
NSMX183_100TRF			
NSMX223_100TRF			
NSMX273_100TRF	2.0 ~ 2.5	5.0 ~ 5.5	5.3 ~ 5.7
NSMX333_100TRF			
NSMX393_100TRF			
NSMX473_100TRF			
NSMX563_100TRF			
NSMX683_100TRF			
NSMX823_100TRF			
NSMX104_100TRF	2.0 ~ 2.5	5.0 ~ 6.0	5.3 ~ 5.7
NSMX124_100TRF			
NSMX154_100TRF			
NSMX184_100TRF			
NSMX224_100TRF	2.0 ~ 2.5	6.0 ~ 6.5	7.8 ~ 8.2

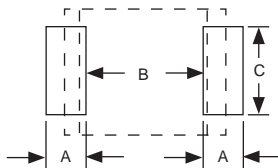

RECOMMENDED REFLOW PROFILE

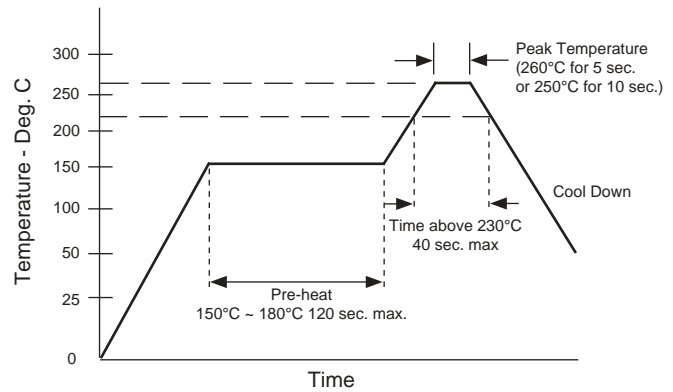

Cleaning

- Use Freon-substitute cleaning solvent
- Immersion, Ultrasonic or Vapor cleaning
- 5 Minutes maximum cleaning
- Less than 50°C
- Ultrasonic conditions: 42 KHz, 20W max
- Please review all other cleaning conditions - techniques with NIC
- Contact: tpmg@niccomp.com