

### Features

- **Input Over-Voltage Protection**
- **Programmable Input Over-Current Protection**
- **Battery Over-Voltage Protection**
- **Over-Temperature Protection**
- **High Immunity of False Triggering**
- **High Accuracy Protection Thresholds**
- **Fault Status Indication**
- **Enable Input**
- **Available in TDFN2x2-8 Package**
- **Lead Free and Green Devices Available (RoHS Compliant)**

### Applications

- **Smart Phones and PDAs**
- **Digital Still Cameras**
- **Portable Devices**

### Pin Configuration

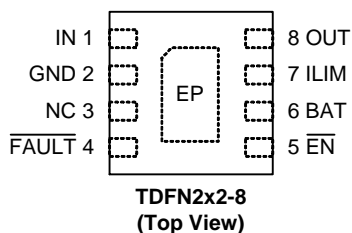

### General Description

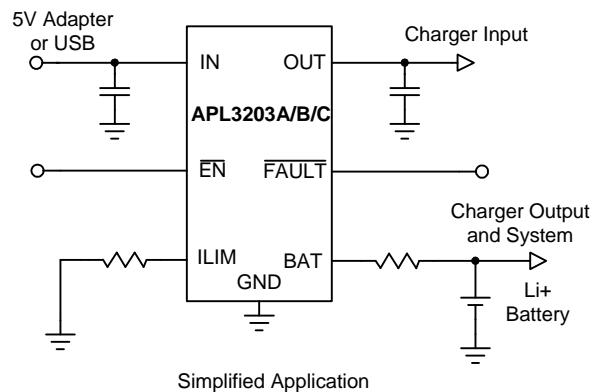

The APL3203A/B/C provide complete Li+ charger protections against over-voltage, over-current, and battery over-voltage. The IC is designed to monitor input voltage, input current, and battery voltage. When any of the monitored parameters are over the threshold, the IC removes the power from the charging system by turning off an internal switch. All protections also have deglitch time against false triggering due to voltage spikes or current transients. The APL3203A/B/C also provide over-temperature protection, a  $\overline{\text{FAULT}}$  output pin to indicate the fault conditions, and the  $\overline{\text{EN}}$  pin to allow the system to disable the IC.

### Simplified Application Circuit

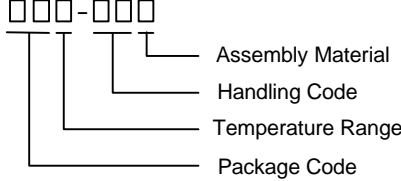

ANPEC reserves the right to make changes to improve reliability or manufacturability without notice, and advise customers to obtain the latest version of relevant information to verify before placing orders.

## Ordering and Marking Information

APL3203A APL3203B APL3203C		Package Code QB : TDFN2x2-8 Operating Ambient Temperature Range I : -40 to 85 °C Handling Code TR : Tape & Reel Assembly Material G : Halogen and Lead Free Device
APL3203A/C QB:		X - Date Code
APL3203B QB:		X - Date Code

Note : ANPEC lead-free products contain molding compounds/die attach materials and 100% matte tin plate termination finish; which are fully compliant with RoHS. ANPEC lead-free products meet or exceed the lead-free requirements of IPC/JEDEC J-STD-020D for MSL classification at lead-free peak reflow temperature. ANPEC defines "Green" to mean lead-free (RoHS compliant) and halogen free (Br or Cl does not exceed 900ppm by weight in homogeneous material and total of Br and Cl does not exceed 1500ppm by weight).

## Absolute Maximum Ratings (Note 1)

Symbol	Parameter	Rating	Unit
$V_{IN}$	IN Input Voltage (IN pin to GND)	-0.3 to 30	V
$V_{OUT}, V_{BAT}$	OUT, BAT Pins to GND Voltage	-0.3 to 7	V
$V_{ILIM}, V_{FAULT}, V_{EN}$	ILIM, FAULT, EN, Pins to GND Voltage	-0.3 to 7	V
$I_{OUT}$	OUT Output Current	2	A
$T_J$	Maximum Junction Temperature	150	°C
$T_{STG}$	Storage Temperature Range	-65 to 150	°C
$T_{SDR}$	Maximum Lead Soldering Temperature, 10 Seconds	260	°C

Note 1: Absolute Maximum Ratings are those values beyond which the life of a device may be impaired. Exposure to absolute maximum rating conditions for extended periods may affect device reliability.

## Thermal Characteristics

Symbol	Parameter	Typical Value	Unit
$\theta_{JA}$	Junction to Ambient Thermal Resistance in Free Air <sup>(Note 2)</sup> TDFN2x2-8	80	°C/W

Note 2 :  $\theta_{JA}$  is measured with the component mounted on a high effective thermal conductivity test board in free air.

## Recommended Operating Conditions

Symbol	Parameter	Range	Unit
$V_{IN}$	IN Input Voltage	4.5 to 5.5	V
$I_{OUT}$	OUT Output Current	0 to 1.5	A
$T_J$	Junction Temperature	-40 to 125	°C
$T_A$	Ambient Temperature	-40 to 85	°C

## Electrical Characteristics

Refer to the typical application circuit. These specifications apply over  $V_{IN}=5V$ ,  $T_A = -40\sim 85^\circ C$ , unless otherwise specified. Typical values are at  $T_A=25^\circ C$ .

Symbol	Parameter	Test Conditions	APL3203A/B/C			Unit
			Min.	Typ.	Max.	
<b>POWER-ON-RESET (POR) AND SUPPLY CURRENT</b>						
$V_{POR}$	IN POR Threshold	$V_{IN}$ rising	2.5	-	2.8	V
	IN POR Hysteresis		-	230	-	mV
$I_{CC}$	IN Supply Current	$\overline{EN} = \text{Low}$	-	250	350	$\mu A$
		$\overline{EN} = \text{High}$	-	100	150	
$T_{B(IN)}$	Input Power-On Blanking Time	$V_{IN}$ rising to $V_{OUT}$ rising	-	8	-	ms
<b>INTERNAL POWER SWITCH AND OUT DISCHARGE RESISTANCE</b>						
	Power Switch On Resistance	$I_{OUT} = 0.5A$	-	250	450	m $\Omega$
	OUT Discharge Resistance	$V_{OUT} = 3V$	-	500	-	$\Omega$
<b>INPUT OVER-VOLTAGE PROTECTION (OVP)</b>						
$V_{OVP}$	Input OVP Threshold	APL3203A/C, $V_{IN}$ rising	5.67	5.85	6.00	V
		APL3203B, $V_{IN}$ rising	6.60	6.80	7.00	
	Input OVP Recovery Hysteresis		-	200	-	mV
	Input OVP Propagation Delay		-	-	1	$\mu s$
$T_{ON(OVP)}$	Input OVP Recovery Time		-	8	-	ms
<b>OVER-CURRENT PROTECTION (OCP)</b>						
$I_{OCP}$	OCP Threshold	$R_{ILIM} = 25k\Omega$	930	1000	1200	mA
	OCP Threshold Accuracy	$I_{OCP} = 300mA$ to $1500mA$	-10	-	+10	%
$T_{B(OCP)}$	OCP Blanking Time		-	176	-	$\mu s$
$T_{ON(OCP)}$	OCP Recovery Time		-	64	-	ms
<b>BATTERY OVER-VOLTAGE PROTECTION</b>						
$V_{BOVP}$	Battery OVP Threshold	$V_{BAT}$ rising	4.30	4.35	4.4	V
	Battery OVP Hysteresis		-	270	-	mV
$I_{BAT}$	BAT Pin Leakage Current	$V_{BAT} = 4.4V$	-	-	20	nA
$T_{B(BOVP)}$	Battery OVP Blanking Time		-	176	-	$\mu s$
<b>EN LOGIC LEVELS</b>						
	$\overline{EN}$ Input Logic High		1.4	-	-	V
	$\overline{EN}$ Input Logic Low		-	-	0.4	V
	$\overline{EN}$ Internal Pull-Low Resistor		-	500	-	k $\Omega$
<b>FAULT LOGIC LEVELS AND DELAY TIME</b>						
	$\overline{FAULT}$ Output Low Voltage	Sink 5mA current	-	-	0.4	V
	$\overline{FAULT}$ Pin Leakage Current	$V_{FAULT} = 5V$	-	-	1	$\mu A$
<b>OVER-TEMPERATURE PROTECTION (OTP)</b>						
$T_{OTP}$	Over-Temperature Threshold		-	140	-	$^\circ C$
	Over-Temperature Hysteresis		-	20	-	$^\circ C$

## Typical Operating Characteristics

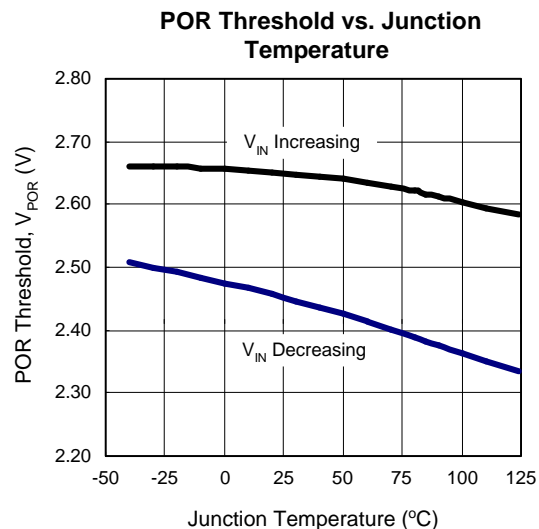
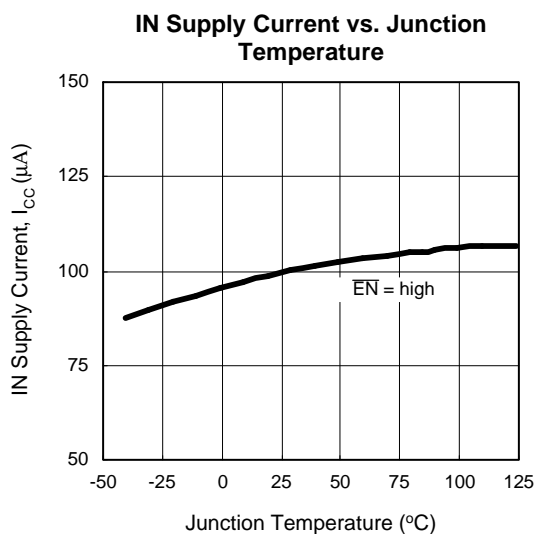
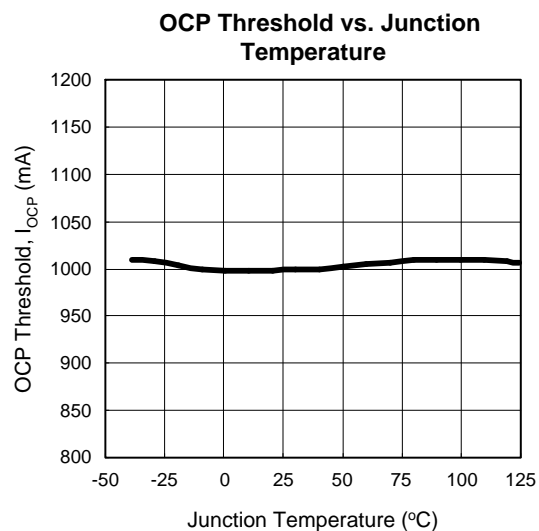
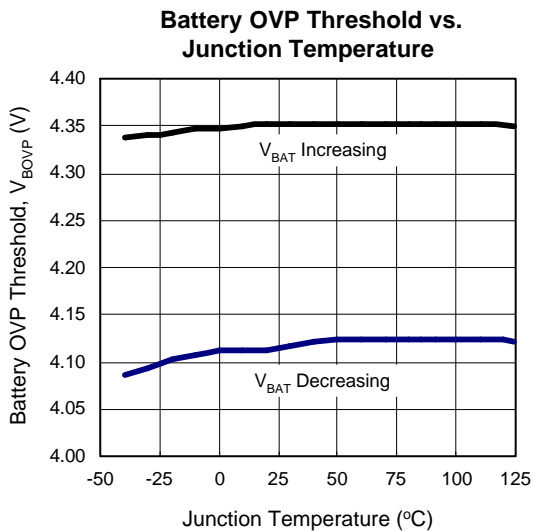
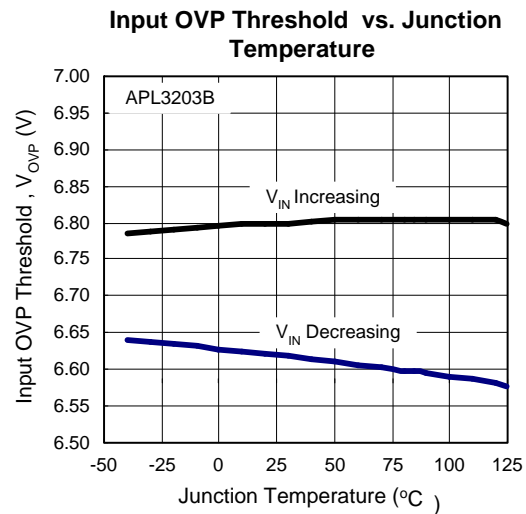
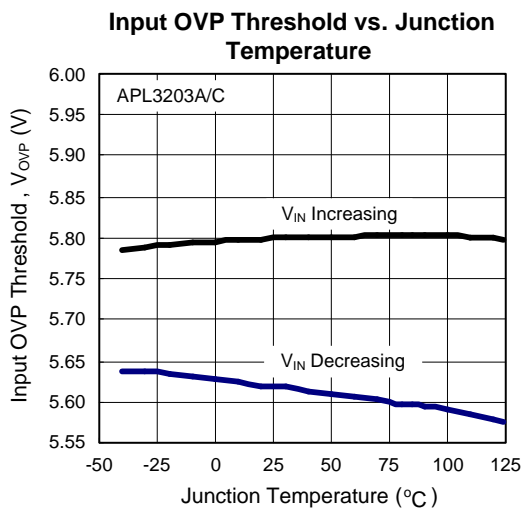

Typical Operating Characteristics (Cont.)

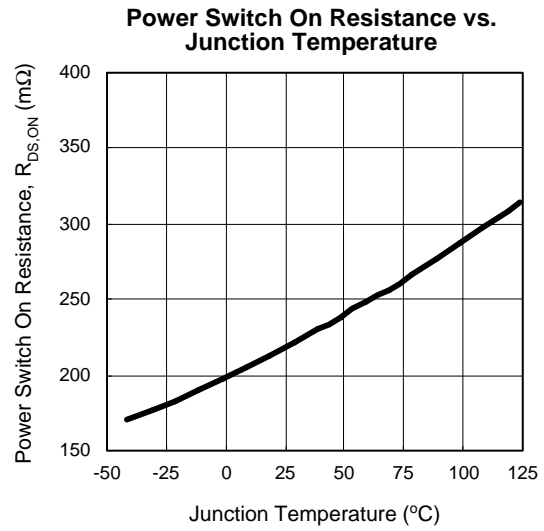
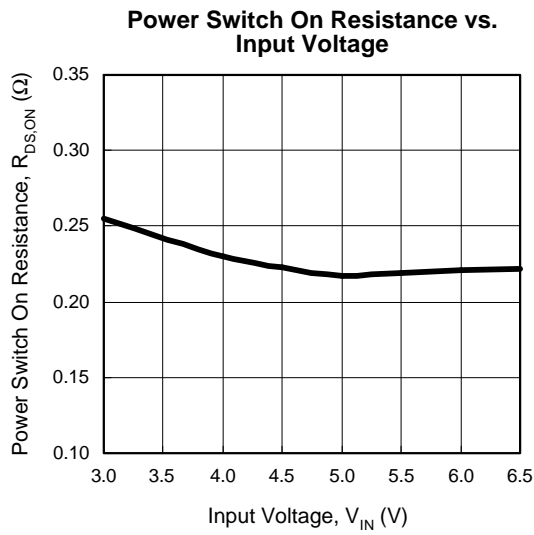

## Operating Waveforms

Refer to the typical application circuit. The test condition is  $V_{IN}=5V$ ,  $T_A=25^\circ C$  unless otherwise specified.

### Normal Power On

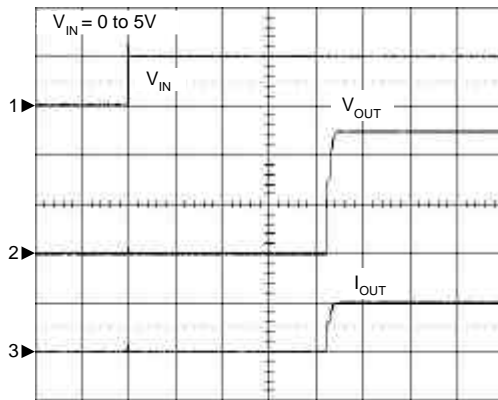

$C_{OUT}=1\mu F$ ,  $C_{IN}=1\mu F$ ,  $R_{OUT}=10\Omega$   
 CH1:  $V_{IN}$ , 5V/Div, DC  
 CH2:  $V_{OUT}$ , 2V/Div, DC  
 CH3:  $I_{OUT}$ , 0.5A/Div, DC  
 TIME: 2ms/Div

### OVP at Power On

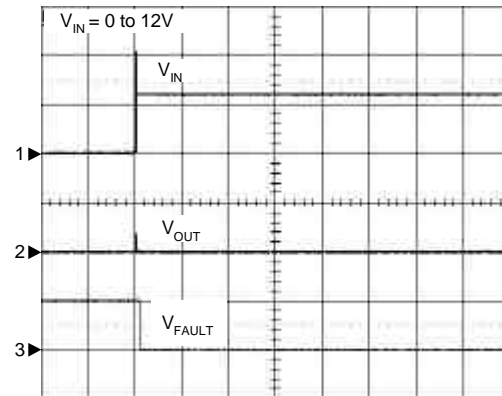

$C_{OUT}=1\mu F$ ,  $C_{IN}=1\mu F$ ,  $R_{OUT}=10\Omega$   
 CH1:  $V_{IN}$ , 10V/Div, DC  
 CH2:  $V_{OUT}$ , 2V/Div, DC  
 CH3:  $V_{FAULT}$ , 5V/Div, DC  
 TIME: 2ms/Div

### Input Over-Voltage Protection

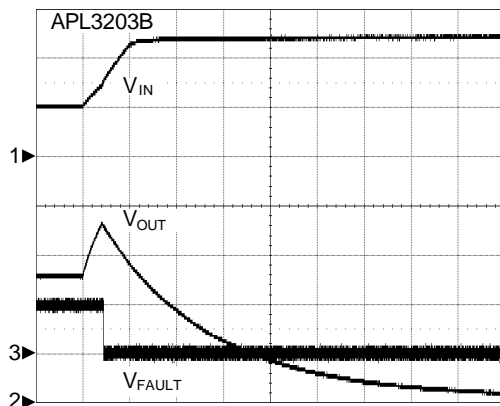

APL3203B  
 $C_{OUT}=1\mu F$ ,  $C_{IN}=1\mu F$ ,  $R_{OUT}=50\Omega$   
 CH1:  $V_{IN}$ , 5V/Div, AC  
 CH2:  $V_{OUT}$ , 2V/Div, DC  
 CH3:  $V_{FAULT}$ , 5V/Div, DC  
 TIME: 20 $\mu s$ /Div

### Input Over-Voltage Protection

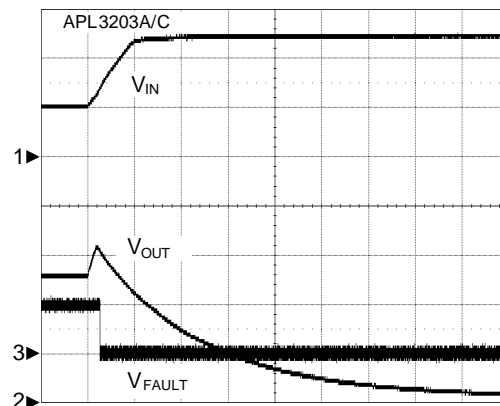

APL3203A/C  
 $C_{OUT}=1\mu F$ ,  $C_{IN}=1\mu F$ ,  $R_{OUT}=50\Omega$   
 CH1:  $V_{IN}$ , 5V/Div, AC  
 CH2:  $V_{OUT}$ , 2V/Div, DC  
 CH3:  $V_{FAULT}$ , 5V/Div, DC  
 TIME: 20 $\mu s$ /Div

## Operating Waveforms (Cont.)

Refer to the typical application circuit. The test condition is  $V_{IN}=5V$ ,  $T_A=25^\circ C$  unless otherwise specified.

### Recovery from Input OVP

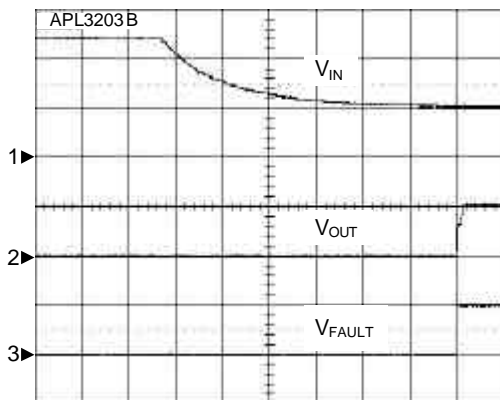

$V_{IN} = 12V$  to  $5V$   
 $C_{OUT} = 1\mu F$ ,  $C_{IN} = 1\mu F$ ,  $R_{OUT} = 50\Omega$   
 CH1:  $V_{IN}$ , 5V/Div, AC  
 CH2:  $V_{OUT}$ , 5V/Div, DC  
 CH3:  $V_{FAULT}$ , 5V/Div, DC  
 TIME: 2ms/Div

### Battery Over-Voltage Protection

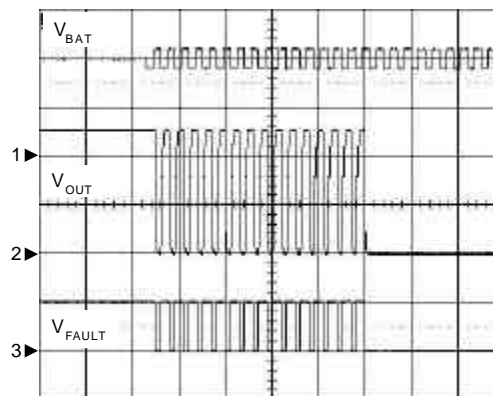

$V_{BAT} = 3.6V$  to  $4.4V$  to  $3.6V$ ,  $R_{OUT} = 33.3\Omega$   
 $C_{OUT} = 1\mu F$ ,  $C_{IN} = 1\mu F$   
 CH1:  $V_{BAT}$ , 2V/Div, DC  
 CH2:  $V_{OUT}$ , 2V/Div, DC  
 CH3:  $V_{FAULT}$ , 5V/Div, DC  
 TIME: 5ms/Div

### Battery Over-Voltage Protection

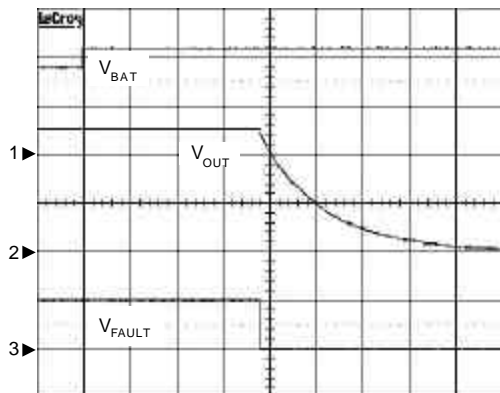

$V_{BAT} = 3.6V$  to  $4.4V$ ,  $R_{OUT} = 33.3\Omega$   
 $C_{OUT} = 1\mu F$ ,  $C_{IN} = 1\mu F$   
 CH1:  $V_{BAT}$ , 2V/Div, DC  
 CH2:  $V_{OUT}$ , 2V/Div, DC  
 CH3:  $V_{FAULT}$ , 5V/Div, DC  
 TIME: 50 $\mu s$ /Div

### Recovery from Battery OVP

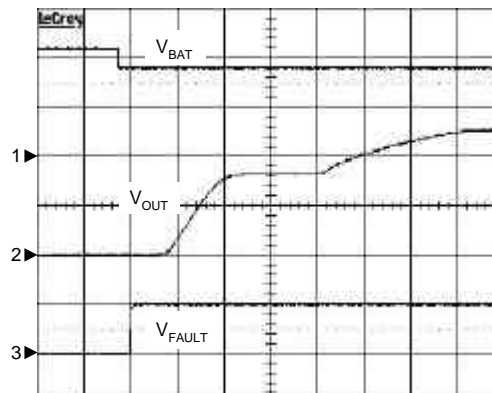

$V_{BAT} = 4.4V$  to  $3.6V$ ,  $R_{OUT} = 33.3\Omega$   
 $C_{OUT} = 1\mu F$ ,  $C_{IN} = 1\mu F$   
 CH1:  $V_{BAT}$ , 2V/Div, DC  
 CH2:  $V_{OUT}$ , 2V/Div, DC  
 CH3:  $V_{FAULT}$ , 5V/Div, DC  
 TIME: 50 $\mu s$ /Div

## Operating Waveforms (Cont.)

Refer to the typical application circuit. The test condition is  $V_{IN}=5V$ ,  $T_A=25^\circ C$  unless otherwise specified.

### Over-Current Protection

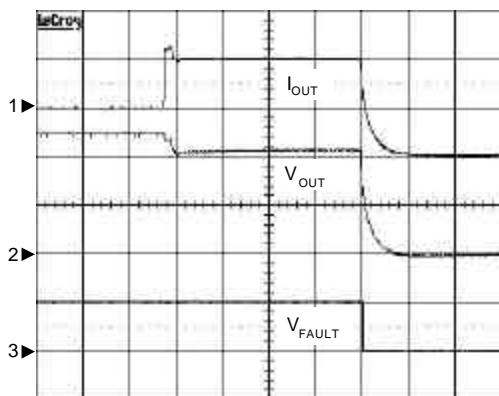

$C_{OUT}=1\mu F$ ,  $C_{IN}=1\mu F$ ,  $I_{OUT}=0.5A$  to  $1.2A$   
 CH1:  $I_{OUT}$ , 0.5A/Div, DC  
 CH2:  $V_{OUT}$ , 2V/Div, DC  
 CH3:  $V_{FAULT}$ , 5V/Div, DC  
 TIME: 50 $\mu s$ /Div

### Over-Current Protection

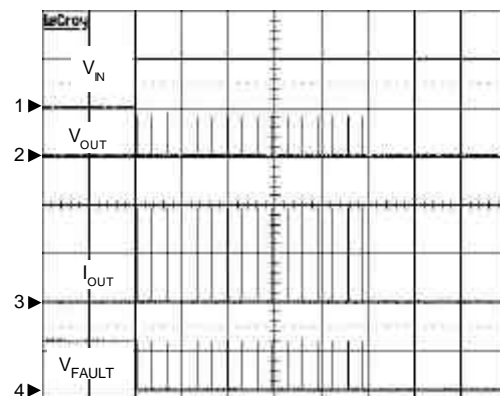

$C_{OUT}=1\mu F$ ,  $C_{IN}=1\mu F$ ,  $R_{OUT}=2.5\Omega$   
 CH1:  $V_{IN}$ , 5V/Div, DC  
 CH2:  $V_{OUT}$ , 5V/Div, DC  
 CH3:  $I_{OUT}$ , 0.5A/Div, DC  
 CH4:  $V_{FAULT}$ , 5V/Div, DC  
 TIME: 200ms/Div



### Pin Description

PIN		FUNCTION
NO.	NAME	
1	IN	Power Supply Input.
2	GND	Ground.
3	NC	No Connection.
4	$\overline{\text{FAULT}}$	Fault Indication Pin. This pin goes low when input OVP, OCP, or battery OVP is detected.
5	$\overline{\text{EN}}$	Enable Input. Pull this pin to high to disable the device and pull this pin to low to enable device.
6	BAT	Battery OVP Sense Pin. Connect to positive terminal of battery through a resistor.
7	ILIM	Over-current Protection Setting Pin. Connect a resistor to GND to set the over-current threshold.
8	OUT	Output Voltage Pin. The output voltage follows the input voltage when no fault is detected.
-	EP	Exposed Thermal Pad. Must be electrically connected to the GND pin.

### Block Diagram

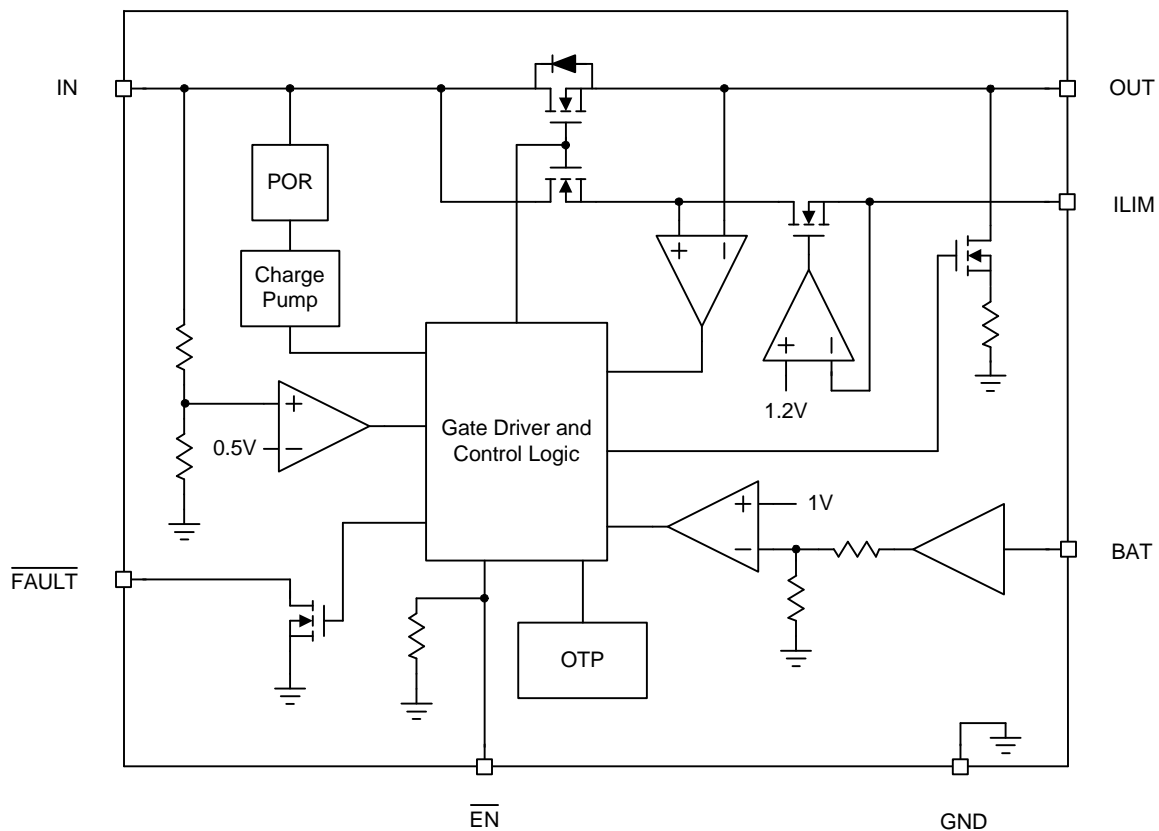

Typical Application Circuit

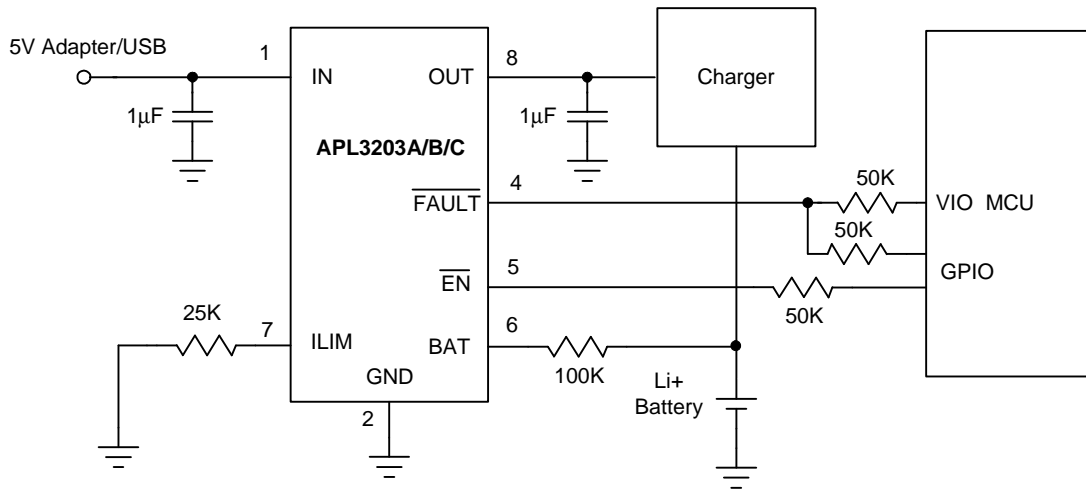

Figure 1. The Typical Protection Circuit for Charger Systems.

## Function Description

### Power-Up

The APL3203A/B/C have a built-in power-on-reset circuit to keep the output shutting off until internal circuitry is operating properly. The POR circuit has hysteresis and a de-glitch feature so that it will typically ignore undershoot transients on the input. When input voltage exceeds the POR threshold and after 8ms blanking time, the output voltage starts a soft-start to reduce the inrush current.

### Input Over-Voltage Protection (OVP)

The input voltage is monitored by the internal OVP circuit. When the input voltage rises above the input OVP threshold, the internal FET will be turned off within 1 $\mu$ s to protect connected system on OUT pin. When the input voltage returns below the input OVP threshold minus the hysteresis, the FET is turned on again after 8ms recovery time. The input OVP circuit has a 200mV hysteresis and a recovery time of  $T_{ON(OVP)}$  to provide noise immunity against transient conditions.

### Over-Current Protection (OCP)

The output current is monitored by the internal OCP circuit. When the output current reaches the OCP threshold, the device limits the output current at OCP threshold level. If the OCP condition continues for a blanking time of  $T_{B(OCP)}$ , the internal power FET is turned off. After the recovery time of  $T_{ON(OCP)}$ , the FET will be turned on again and the output current is monitored again. The APL3203A/B/C have a built-in counter. When the total count of OCP fault reaches 16, the FET is turned off permanently, requiring either a  $V_{IN}$  POR or  $\overline{EN}$  re-enable again to restart. The OCP threshold is programmed by a resistor  $R_{ILIM}$  connected from ILIM pin to GND. The OCP threshold is calculated by the following equation:

$$I_{OCP} = \frac{K_{ILIM}}{R_{ILIM}}$$

where

$$K_{ILIM} = 25000A\Omega$$

### Battery Over-Voltage Protection

The APL3203A/B/C monitor the BAT pin voltage for battery over-voltage protection. The battery OVP threshold is internally set to 4.35V. When the BAT pin voltage exceeds the battery OVP threshold for a blanking time of  $T_{B(BOVP)}$ ,

the internal power FET is turned off. When the BP voltage returns below the battery OVP threshold minus the hysteresis, the FET is turned on again. The APL3203A/B/C have a built-in counter. When the total count of battery OVP fault reaches 16, the FET is turned off permanently, requiring either a  $V_{IN}$  POR or  $\overline{EN}$  re-enable again to restart.

### Over-Temperature Protection

When the junction temperature exceeds 140°C, the internal thermal sense circuit turns off the power FET and allows the device to cool down. When the device's junction temperature cools by 20°C, the internal thermal sense circuit will enable the device, resulting in a pulsed output during continuous thermal protection. Thermal protection is designed to protect the IC in the event of over temperature conditions. For normal operation, the junction temperature cannot exceed  $T_J = +125^\circ\text{C}$ .

### $\overline{\text{FAULT}}$ Output

The APL3203A/B/C provide an open-drain output to indicate that a fault has occurred. When any of input OVP, OCP, battery OVP, is detected, the  $\overline{\text{FAULT}}$  goes low to indicate that a fault has occurred. Since the  $\overline{\text{FAULT}}$  pin is an open-drain output, connecting a resistor to a pull high voltage is necessary.

### Enable/Shutdown

Pull the  $\overline{EN}$  pin voltage above 1.4V to disable the device and pull  $\overline{EN}$  pin voltage below 0.4V to enable the device. The  $\overline{EN}$  pin has an internal pull-down resistor and can be left floating. When the IC is latched off due to the total count of OCP or battery OVP reaches 16, disable and re-enable the device with the  $\overline{EN}$  pin can clear the counter.

Function Description (Cont.)

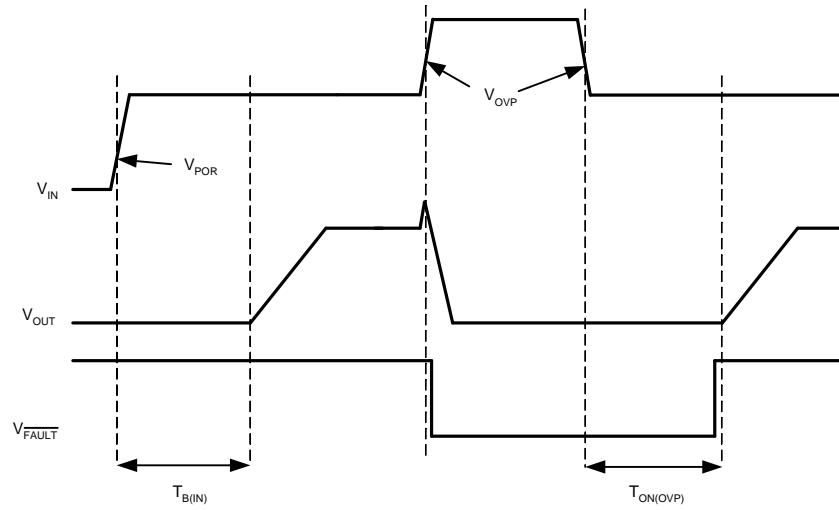

Figure 2. OVP Timing Chart

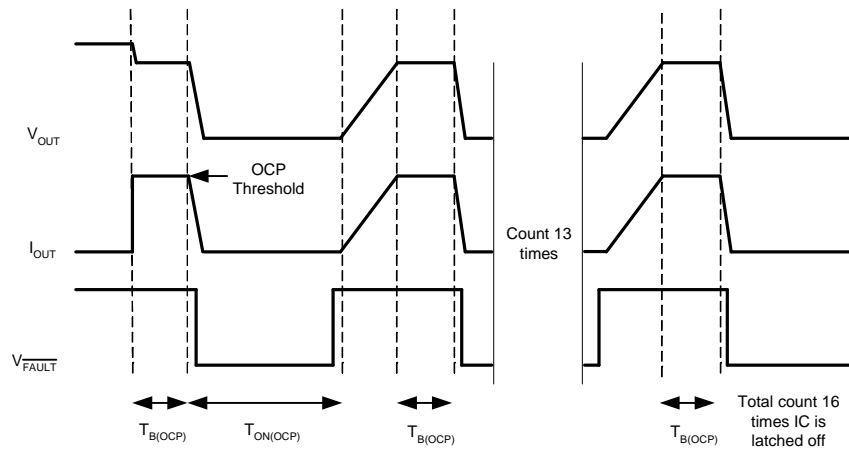

Figure 3. OCP Timing Chart

Function Description (Cont.)

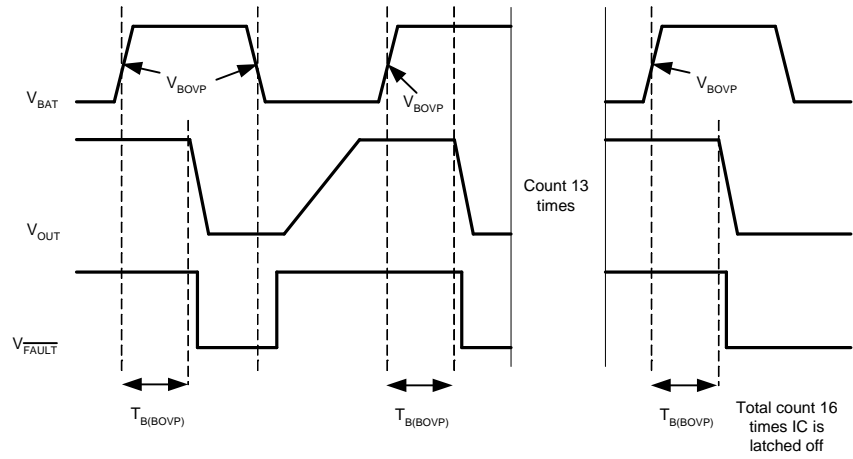

Figure 4. Battery OVP Timing Chart

## Application Information

### R<sub>BAT</sub> Selection

Connect the BAT pin to the positive terminal of battery through a resistor R<sub>BAT</sub> for battery OVP function. The R<sub>BAT</sub> limits the current flowing from BAT to battery in case of BAT pin is shortened to VIN pin under a failure mode. The recommended value of R<sub>BAT</sub> is 100kΩ. In the worse case of an IC failure, the current flowing from the BAT pin to the battery is:

$$(30V-3V)/100k\Omega = 270\mu A$$

where the 30V is the maximum IN voltage and the 3V is the minimum battery voltage. The current is so small and can be absorbed by the charger system.

The disadvantage with the large R<sub>BAT</sub> is that the error of the battery OVP threshold will be increased. The additional error is the voltage drop across the R<sub>BAT</sub> because of the BAT bias current. When R<sub>BAT</sub> is 100kΩ, the worse-case additional error is 100kΩ×20nA=2mV, which is acceptable in most applications.

### R<sub>EN</sub> Selection

For the same reason as the BAT pin case, the EN pin should be connected to the MCU GPIO pin through a resistor. The value of the R<sub>EN</sub> is dependent on the IO voltage of the MCU.

Since the IO voltage is divided by R<sub>EN</sub> and  $\overline{EN}$  internal pull low resistor for  $\overline{EN}$  voltage. It has to be ensured that the  $\overline{EN}$  voltage is above the  $\overline{EN}$  logic high voltage when the GPIO output of the MCU is high.

### FAULT Output

Since the FAULT pin is an open-drain output, connecting a resistor R<sub>UP</sub> to a pull high voltage is necessary. It is also recommended that connect the FAULT to the MCU GPIO through a resistor R<sub>FAULT</sub>. The R<sub>FAULT</sub> prevents damage to the MCU under a failure mode. The recommended value of the resistors should be between 10kΩ to 100kΩ.

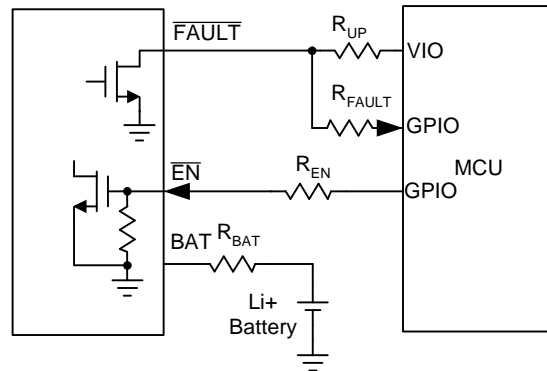

Figure 5. R<sub>UP</sub>, R<sub>FAULT</sub>, R<sub>EN</sub> and R<sub>BAT</sub>

### Capacitor Selection

The input capacitor is for decoupling and prevents the input voltage from overshooting to dangerous levels. In the AC adapter hot plug-in applications or load current step-down transient, the input voltage has a transient spike due to the parasitic inductance of the input cable. A 25V, X5R, dielectric ceramic capacitor with a value between 1μF and 4.7μF placed close to the IN pin is recommended.

The output capacitor is for output voltage decoupling, and also can be as the input capacitor of the charging circuit. At least, a 1μF, 10V, X5R capacitor is recommended.

### Layout Consideration

In some failure modes, a high voltage may be applied to the device. Make sure the clearance constraint of the PCB layout must satisfy the design rule for high voltage.

The exposed pad of the TDFN2x2-8 performs the function of channeling heat away. It is recommended that connect the exposed pad to a large copper ground plane on the backside of the circuit board through several thermal vias to improve heat dissipation.

The input and output capacitors should be placed close to the IC. R<sub>LIM</sub> also should be placed close to the IC.

The high current traces like input trace and output trace must be wide and short.

Package Information

TDFN2x2-8

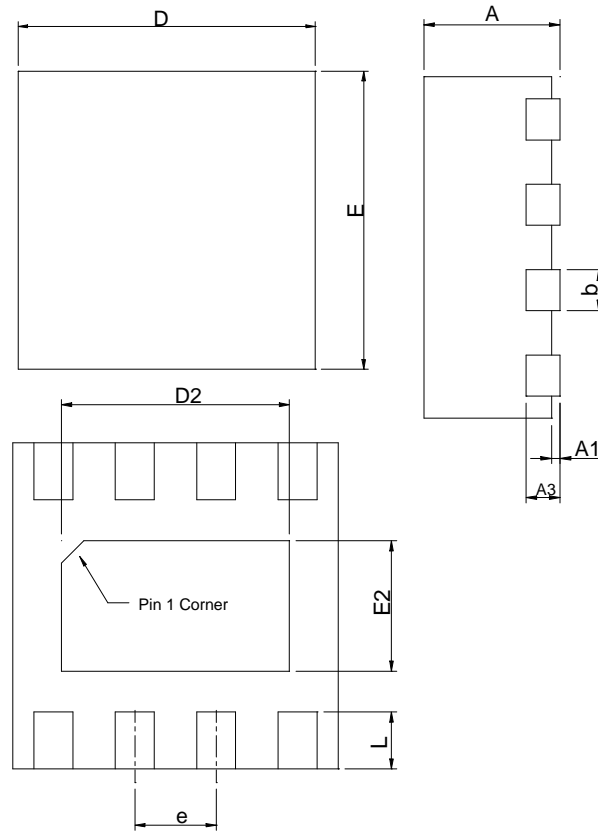

SYMBOL	TDFN2x2-8			
	MILLIMETERS		INCHES	
	MIN.	MAX.	MIN.	MAX.
A	0.70	0.80	0.028	0.031
A1	0.00	0.05	0.000	0.002
A3	0.20 REF		0.008 REF	
b	0.18	0.30	0.007	0.012
D	1.90	2.10	0.075	0.083
D2	1.00	1.60	0.039	0.063
E	1.90	2.10	0.075	0.083
E2	0.60	1.00	0.024	0.039
e	0.50 BSC		0.020 BSC	
L	0.30	0.45	0.012	0.018

### Carrier Tape & Reel Dimensions

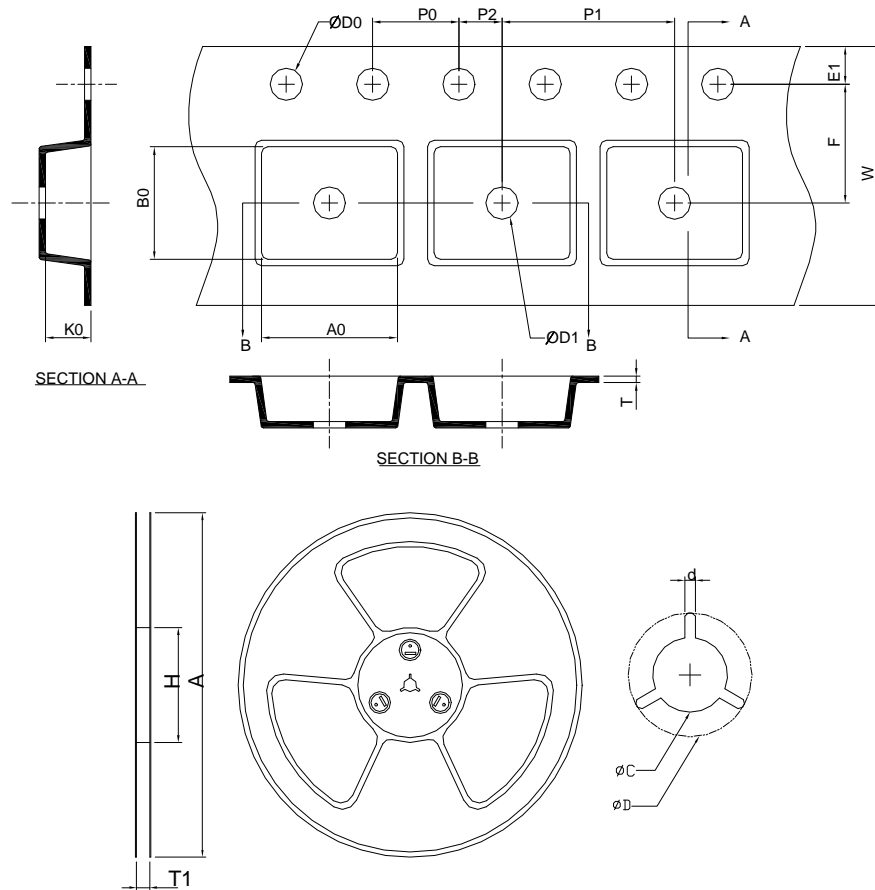

Application	A	H	T1	C	d	D	W	E1	F
TDFN2x2-8	178.0 ±0.00	50 MIN.	8.4+2.00 -0.00	13.0+0.50 -0.20	1.5 MIN.	20.2 MIN.	8.0 ±0.20	1.75 ±0.10	3.50 ±0.05
	P0	P1	P2	D0	D1	T	A0	B0	K0
	4.0 ±0.10	4.0 ±0.10	2.0 ±0.05	1.5+0.10 -0.00	1.5 MIN.	0.6+0.00 -0.4	3.35 MIN	3.35 MIN	1.30 ±0.20

(mm)

### Devices Per Unit

Package Type	Unit	Quantity
TDFN2x2-8	Tape & Reel	3000



## Taping Direction Information

TDFN2x2-8  
(for APL3203A/B)

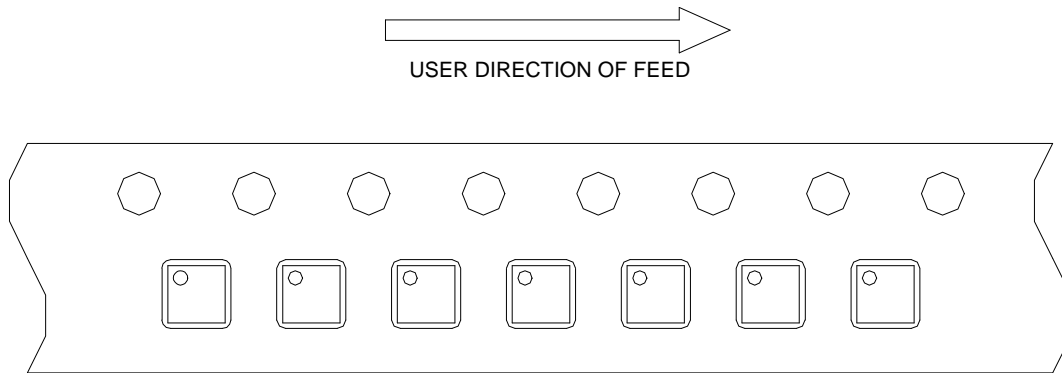

(Only for APL3203C)

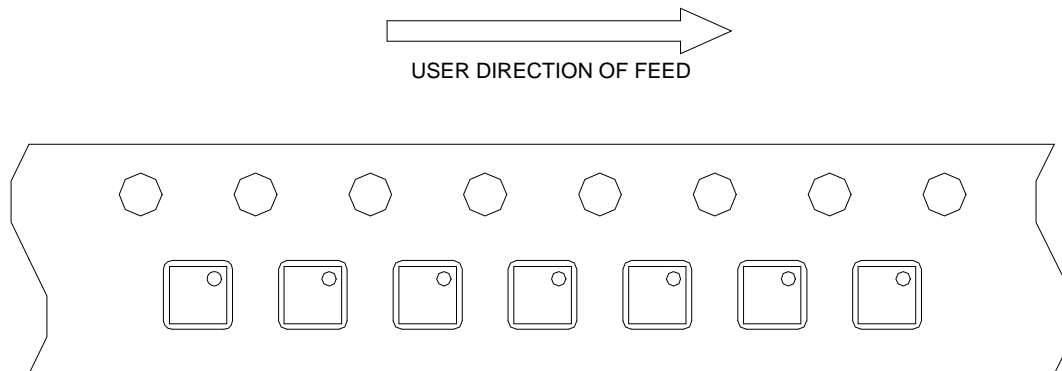

Classification Profile

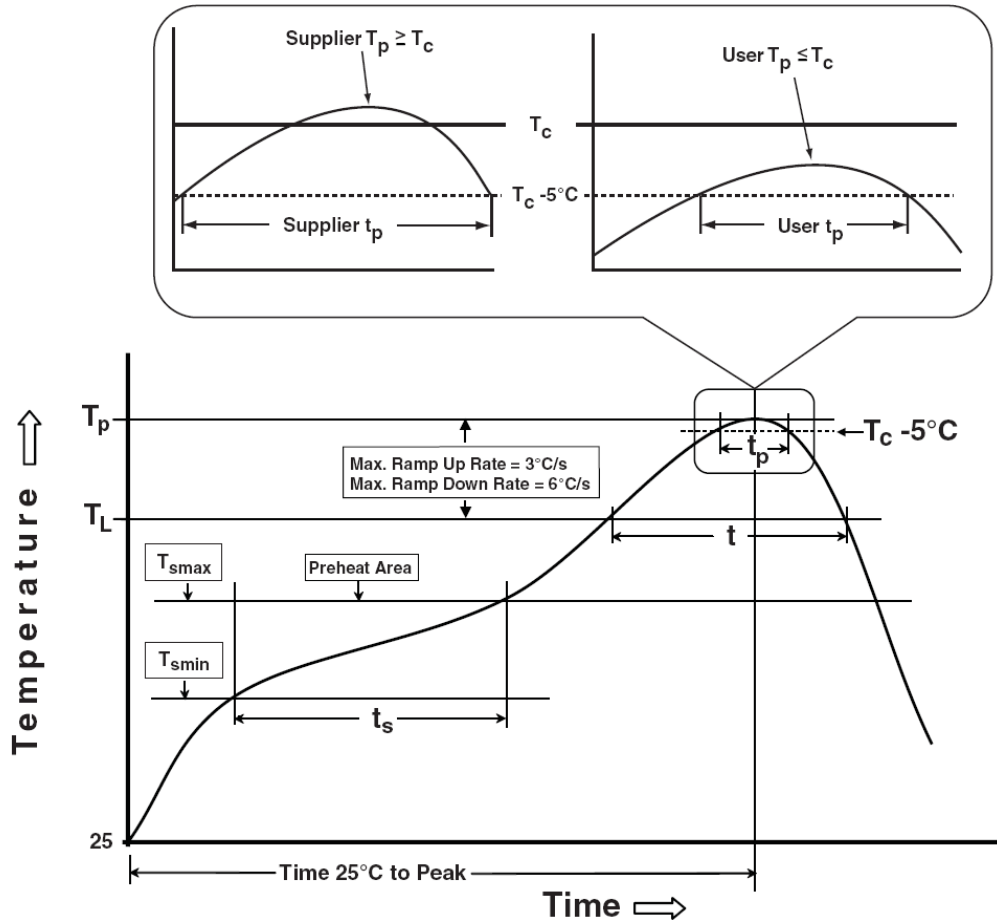

### Classification Reflow Profiles

Profile Feature	Sn-Pb Eutectic Assembly	Pb-Free Assembly
<b>Preheat &amp; Soak</b>		
Temperature min ( $T_{smin}$ )	100 °C	150 °C
Temperature max ( $T_{smax}$ )	150 °C	200 °C
Time ( $T_{smin}$ to $T_{smax}$ ) ( $t_s$ )	60-120 seconds	60-120 seconds
Average ramp-up rate ( $T_{smax}$ to $T_p$ )	3 °C/second max.	3°C/second max.
Liquidous temperature ( $T_L$ )	183 °C	217 °C
Time at liquidous ( $t_L$ )	60-150 seconds	60-150 seconds
Peak package body Temperature ( $T_p$ )*	See Classification Temp in table 1	See Classification Temp in table 2
Time ( $t_p$ )** within 5°C of the specified classification temperature ( $T_c$ )	20** seconds	30** seconds
Average ramp-down rate ( $T_p$ to $T_{smax}$ )	6 °C/second max.	6 °C/second max.
Time 25°C to peak temperature	6 minutes max.	8 minutes max.
* Tolerance for peak profile Temperature ( $T_p$ ) is defined as a supplier minimum and a user maximum.		
** Tolerance for time at peak profile temperature ( $t_p$ ) is defined as a supplier minimum and a user maximum.		

Table 1. SnPb Eutectic Process – Classification Temperatures ( $T_c$ )

Package Thickness	Volume mm <sup>3</sup> <350	Volume mm <sup>3</sup> ≥350
<2.5 mm	235 °C	220 °C
≥2.5 mm	220 °C	220 °C

Table 2. Pb-free Process – Classification Temperatures ( $T_c$ )

Package Thickness	Volume mm <sup>3</sup> <350	Volume mm <sup>3</sup> 350-2000	Volume mm <sup>3</sup> >2000
<1.6 mm	260 °C	260 °C	260 °C
1.6 mm – 2.5 mm	260 °C	250 °C	245 °C
≥2.5 mm	250 °C	245 °C	245 °C

### Reliability Test Program

Test item	Method	Description
SOLDERABILITY	JESD-22, B102	5 Sec, 245°C
HOLT	JESD-22, A108	1000 Hrs, Bias @ 125°C
PCT	JESD-22, A102	168 Hrs, 100%RH, 2atm, 121°C
TCT	JESD-22, A104	500 Cycles, -65°C~150°C
HBM	MIL-STD-883-3015.7	VHBM 2KV
MM	JESD-22, A115	VMM 200V
Latch-Up	JESD 78	10ms, 1 <sub>tr</sub> 100mA

## Customer Service

### **Anpec Electronics Corp.**

#### Head Office :

No.6, Dusing 1st Road, SBIP,  
Hsin-Chu, Taiwan, R.O.C.  
Tel : 886-3-5642000  
Fax : 886-3-5642050

#### Taipei Branch :

2F, No. 11, Lane 218, Sec 2 Jhongsing Rd.,  
Sindian City, Taipei County 23146, Taiwan  
Tel : 886-2-2910-3838  
Fax : 886-2-2917-3838