

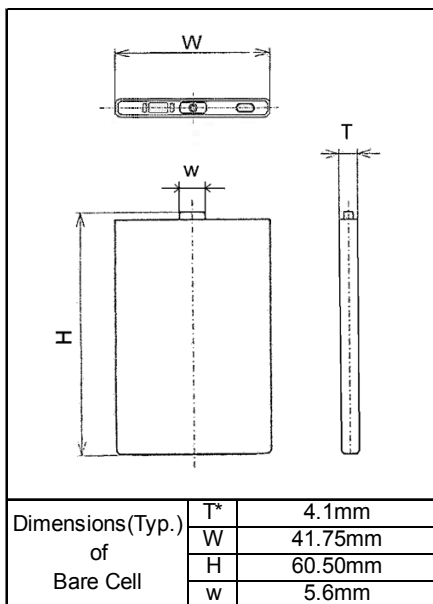

# Cell Type UF424261F

## Specifications



Nominal Capacity		Min. 1300mAh
Nominal Voltage		3.7V
Charging Method		Constant Current -Constant Voltage
Charging Voltage		4.2V
Charging Current		Std. 1300mA
Charging Time		3hrs.
Ambient Temperature	Charge	0 ~ +40°C
	Discharge	-20 ~ +60°C
	Storage	-20 ~ +50°C
Weight (Max.)		26.2g
Dimensions (Max.)	(T)**	4.20mm
	(W)	41.85mm
	(H)	60.80mm
Volumetric Energy Density		450Wh/l
Gravimetric Energy Density		184Wh/kg

\*Discharged State after Assembling

\*\*The maximum thickness of the standard shipment charging condition

## Typical Characteristics

### Discharge rate characteristics

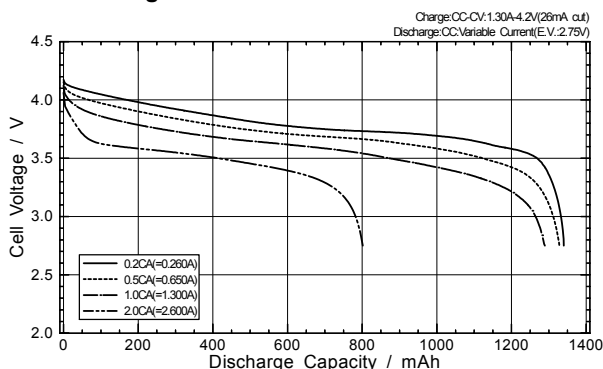

### Discharge temperature characteristics

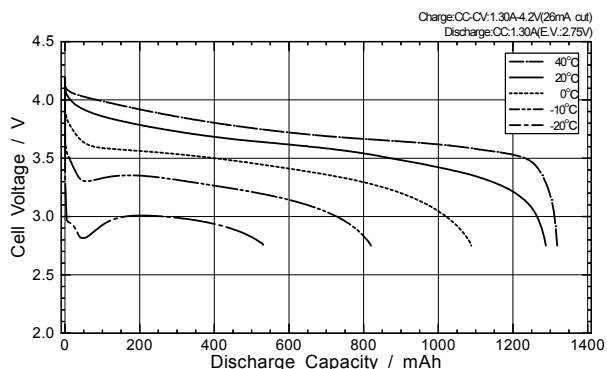

### Charge characteristics

