

# POWERTIP TECH. CORP.

DISPLAY DEVICES FOR BETTER ELECTRONIC DESIGN

## Specification For Approval

### 【產品規格書】

Customer : ELATEC

Model Type : LCD Module

Sample Code : \_\_\_\_\_

Mass Production Code : PG12864LRU-FTA-H

Edition : 0

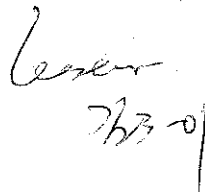
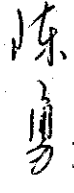
Customer Sign	Sales Sign	Approved By	Prepared By
		 7/23-01	 7/23-01

# CONTENTS

## 1.SPECIFICATIONS

- 1.1 Features
- 1.2 Mechanical Specifications
- 1.3 Absolute Maximum Ratings
- 1.4 DC Electrical Characteristics
- 1.5 Optical Characteristics
- 1.6 Backlight Characteristics

## 2.MODULE STRUCTURE

- 2.1 Counter Drawing
- 2.2 Interface Pin Description
- 2.3 Timing Characteristics
- 2.4 Display command
- 2.5 Character Pattern



**POWERTIP TECHNOLOGY CORPORATION**  
DISPLAY DEVICES FOR BETTER ELECTRONIC DESIGN

## 1. SPECIFICATIONS

### 1.1 Features

- Full dot-matrix structure with 128 dots \*64 dots
- 1/64 Duty, 119 bias
- STN LCD, positive, yellow green
- Transflective LCD
- 6 o'clock viewing angle
- 8 bits parallel data input ,with controller IC T6963C, QFP type
- Built-in LED backlight

### 1.2 Mechanical Specifications

- Outline dimension : 78.0mm(L) \*70.0mm(W)\*13.8mm (H)
- Viewing area : 62.0mm \*44.0mm
- Active area : 56.27mm \*38.35mm
- Dot size 0.39mm \*0.55mm
- Dot pitch 0.44mm \*0.6mm

### 1.3 Absolute Maximum Ratings

Item	Symbol	Conditions	Min.	Max.	Unit
Power supply Voltage	VDD	-	0	7.0	V
LCD drive Supply voltage	VDD-VEE	-	3	19.0	V
Input voltage	VIN	-	-0.3	VDD+0.3	V
Operating temperature	TOPR	-	-20	70	°C
Storage temperature	TSTG	-	-30	80	°C
Humidity*1	HD	-	-	90	%RH

### 1.4 DC Electrical Characteristics

VDD=+5V+10% VSS=0V TA=25°C

Item	Symbol	Condition	Min.	Typ.	Max.	Unit
Logic Supply voltage	VDD	-	4.5	5	5.5	V
“H” input voltage	VIH	-	0.8VDD	-	VDD	V
“L” input voltage	VIL	-	-	-	0.2VDD	V
“H” output voltage	VOH	-	VDD-0.3	-	-	V
“L” output voltage	VOL	-	-	-	0.3	V
Supply current	IDD	VDD=5V	-	10.2	-	mA
LCD driving voltage	VOP	VDD-V0	-	9.1	-	V



**PO WERTIP TECHNOLOGY CORPORATION**  
 lu DISPLAY DEVICES FOR BETTER ELECTRONIC DESIGN

### 1.5 Optical Characteristics

1/64 duty, 1/9 bias,  $V_{op}=9.1V$ ,  $T_a=25^\circ C$

Item	Symbol	Conditions	Min.	Typ.	Max	Reference
Viewing angle	$\theta$	$C > 2.0, \phi = 0^\circ$	$30^\circ$	-	-	Notes 1 & 2
Contrast	C	$\theta = 5^\circ, \phi = 0^\circ$	2	3	-	Note 3
Response time(rise)	$t_r$	$\theta = 5^\circ, \phi = 0^\circ$	-	300ms	500ms	Note 4
Response time(fall)	$t_f$	$\theta = 5^\circ, \phi = 0^\circ$	-	500ms	800ms	Note 4

Note 1: Definition of angles  $\theta$  and  $\phi$

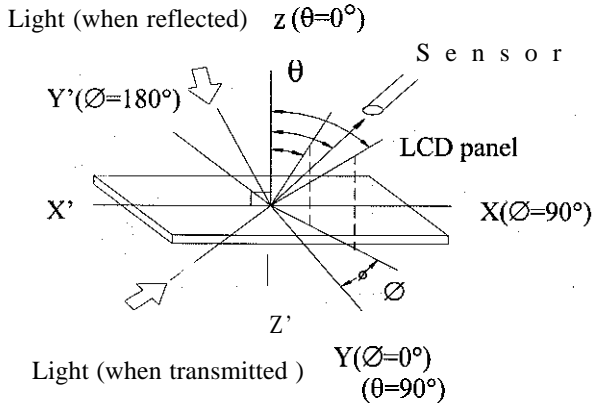

Note 2: Definition of viewing angles  $\theta_1$  and  $\theta_2$

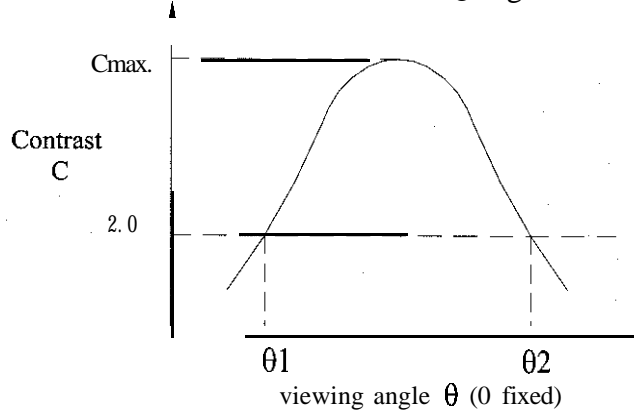

Note: Optimum viewing angle with the naked eye and viewing angle  $\theta$  at  $C_{max}$ . Above are not always the same

Note 3: Definition of contrast C

Brightness (reflection) of unselected dot ( $B_2$ )

Brightness (reflection) of selected dot ( $B_1$ )

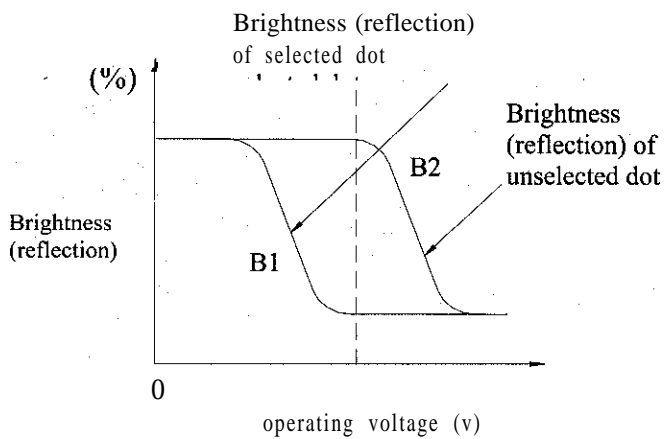

Note 4: Definition of response time

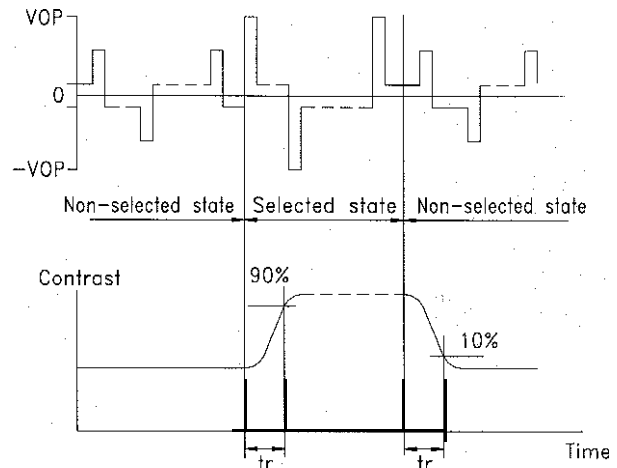

Note: Measured with a transmissive LCD panel which is displayed 1 cm\*

$V_{opr}$  : Operating voltage  
 $t_r$  : Response time (rise)

$f_{FRM}$  : Frame frequency  
 $t_f$  : Response time (fall)



**POWERTIP TECHNOLOGY CORPORATION**

DISPLAY DEVICES FOR BETTER ELECTRONIC DESIGN

## 1.6 Backlight Characteristic Backlight Characteristic

The LCD Module is backlight using a LED panel

- .Maximum Ratings

Item	Symbol	Conditions	Min.	Max.	Unit
Forward current	IF	TA=25°C	-	875	mA
Reverse voltage	VR	TA=25°C	-	8	V
Power dissipation	PO	TA=25°C	-	4.02	W
Operating Temperature	TOPR	-	-20	70	°C
Storage temperature	TSTG	-	-40	80	°C
Soldering Temperature : 3 Sec. At 2mm From The Reflector Edge			260 °C		

- .Electrical Ratings

Item	Symbol	Condition	Min.	Typ.	Max.	Unit
Forward voltage	VF	25°C	3.8	4.2	4.6	V
Reverse current	IR	25°C	-	-	0.2	mA
Luminous intensity	IV	IF=350mA	220	270	-	cd/m <sup>2</sup>
Wavelength	HUE	IF=350mA	569	-	576	nm
Color	Yellow Green					



**PO WERTIP TECHNOLOGY CORPORATION**  
DISPLAY DEVICES FOR BETTER ELECTRONIC DESIGN

## 2. MODULE STRUCTURE

### 2.1 Counter Drawing

\*See Appendix

### 2.2 Interface Pin Description

Pin No.	Symbol	Function
1	FG	Frame ground (connected to metal bezel )
2	VSS	Signal ground (GND)
3	Vdd	Power supply for logic (+5V)
4	V0	Power supply for lcd drive (should be variable)
5	$\overline{WR}$	Data write (write data to the module at "L")
6	$\overline{RD}$	Data read (read data from the module at "L")
7	$\overline{CE}$	Chip enable for the module (active at "L")
8	$C/\overline{D}$	$C/\overline{D} = "H"$ : read or write command $C/\overline{D} = "L"$ :read or write data.
9	$\overline{RESET}$	Controller reset (module reset)
10~17	D0~D7	Data bus (D0=MSB, D7=LSB)
18	FS	Font select :open or connect to Vdd : 6*8 Dots font connect to Vss : 8*8 Dots font
19	K	Power supply for LED B/L "Ground"
20	A	Power supply for LED B/L "+"

Contrast Adjust

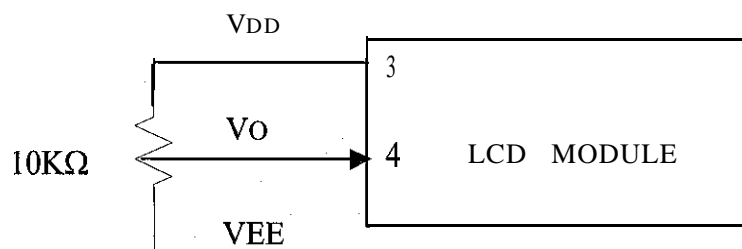

**POWERTIP TECHNOLOGY CORPORATION**

DISPLAY DEVICES FOR BETTER ELECTRONIC DESIGN

### 2.3 Timing Characteristics

#### Bus Timing

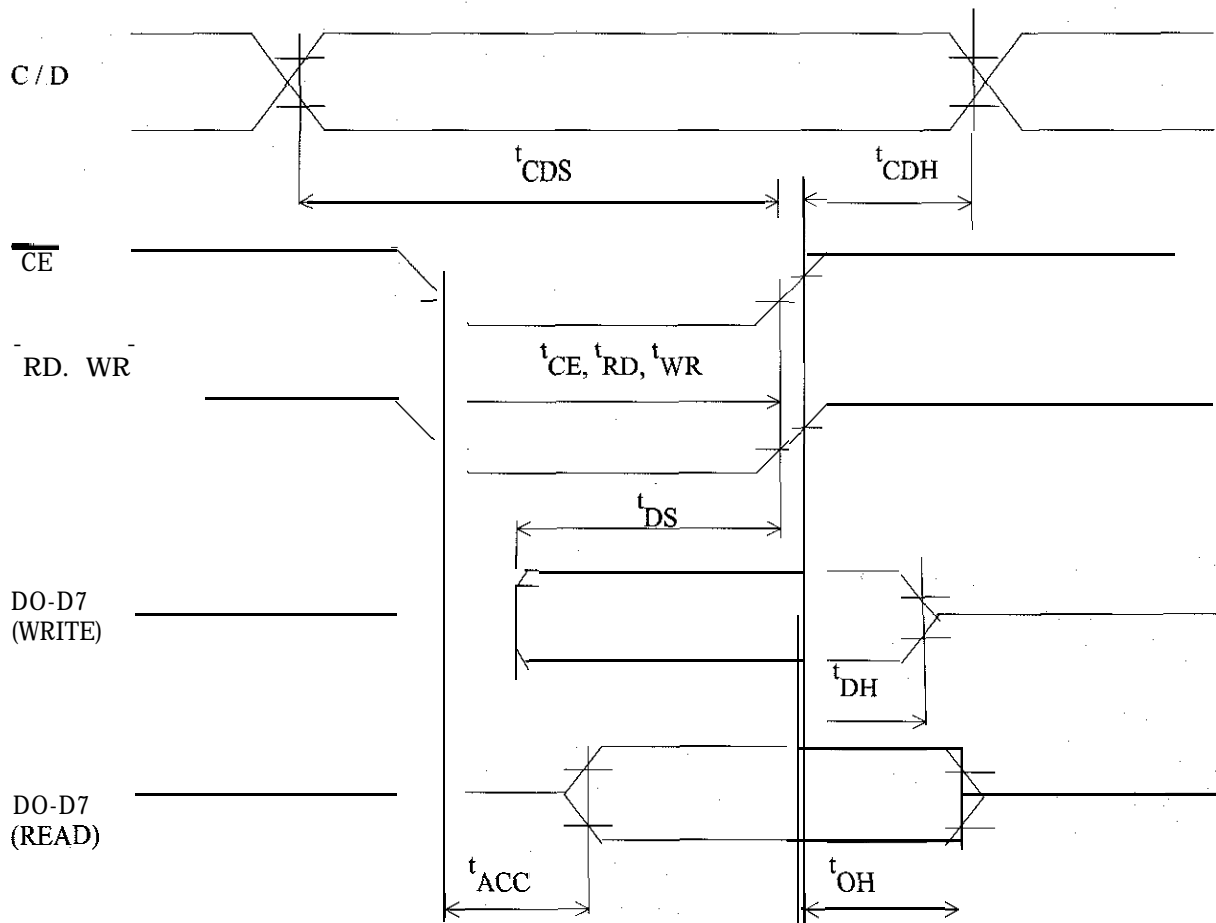

## Read cycle

VDD=+5V±10%,VSS=0V,TA=25°C

Item	Symbol	Condition	Min.	Max	Unit
		s			
C/D Set up time	tCDS	-	100	-	ns
C/D Hold time	tCDH	-	10	-	ns
$\overline{CE}$ , $\overline{RD}$ , $\overline{WR}$ Pulse width	tCE,tRD,tWR	-	80	-	ns
Access time	tACC	-	-	150	ns
Output hold time	tOH	-	10	50	ns

## Write cycle

Item	Symbol	Condition	Min.	Max	Unit
		s			
C/D Set up time	tCDS	-	100		ns
C/D Hold time	tCDH	-	10	-	ns
$\overline{CE}$ , $\overline{RD}$ , $\overline{WR}$ Pulse width	tCE,tRD,tWR	-	80	-	ns
Data set up time	tDS	-	80	-	ns
Data hold time	tDH	-	40	-	ns



**PO WERTIP TECHNOLOGY CORPORATION**  
**DISPLAY DEVICES FOR BETTER ELECTRONIC DESIGN**



## 2.4 Display command

### 1.Register Set

Code	Hex .	Function	D1	D2
00100001	21H	Cursor pointer set	X ADRS	Y ADRS
00100010	22H	Offset register set	Data	00H
00100100	24H	Address pointer set	Low ADRS	High ADRS

#### (1) Cursor pointer set

The position of cursor is specified by X ADRS, Y ADRS. The cursor position is moved only by this command. The cursor pointer doesn't have the function of increment and decrement. The shift of cursor are set by this command. X ADRS, Y ADRS are specified following.

X ADRS                      00H-4FH (Lower 7bits are valid)

Y ADRS                      00H~1FH (Lower 5 bits are valid)

1. 1 screen drive

X ADRS 00-4FH

Y ADRS 00H~0FH

2. 2 screens drive

X ADRS 00~4FH

Y ADRS 00H~0FH  
Upper screen

Y ADRS 10H~1FH  
Lower screen

#### (2) Offset register set

The offset register is used to determine external character generator RAM area.

T693C has 16 bit address lines as follow.

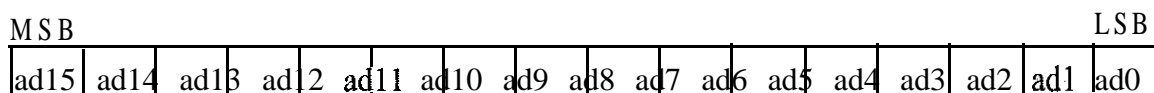

The upper 5 bit (ad15~ad11) are determined by offset register. The middle 8 bit (ad10~ad3) are determined by character code. The lower 3 bit (ad2~ad0) are determined by vertical counter. The lower 5 bit of D1 (data) are valid.

The data format of external character generator RAM.



**POWERTIP TECHNOLOGY CORPORATION**

DISPLAY DEVICES FOR BETTER ELECTRONIC DESIGN



(3)Address pointer set

The address pointer set command is used to indicate the start address for writing (or reading) to external RAM

The flow chart address pointer set command

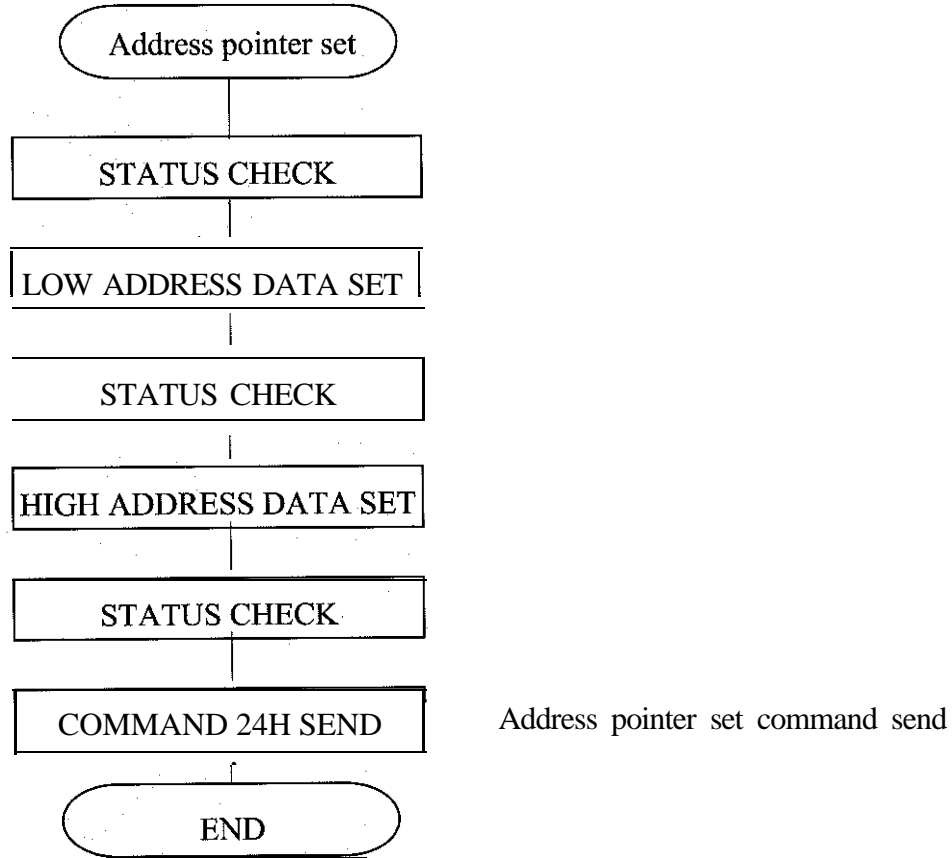

**2.Control word set**

Code	Hex.	Function	D1	D2
01000000	40H	Text home address set	Low address	High address
01000001	41H	Text area set	Columns	00H
01000010	42H	Graphic home address set	Low address	High address
01000011	43H	Graphic area set	Columns	00H

The home address and column size are defined by this command.

(1)Text home address set

The starting address of external display RAM for Text display is defined by this command. The



text home address shows the left end and most upper position.

The relationship of external display RAM address and display position

TH		TH+CL
TH+TA		TH+TA+CL
(TH+TA)+TA		TH+2TA+CL
(TH+2TA)+TA		TH+3TA+CL
TH+(n-1)TA		TH+(n-1)TA+CL

TH : Text home address

TA : Text area number (columns)

CL : Columns are fixed by hardware. (pin-programmable)

(Example)

Text home address : 0000H

Text area : 0020H

MD2=H, MD3=H : 32 columns

DUAL=H, MDX=L, MD1=H : 4 lines

0000H	0001H		001EH	001FH
0020H	0021H		003EH	003FH
0040H	0041H		005EH	005FH
0060H	0061H		007EH	007FH

(2)Graphic home address set

The starting address of external display RAM for Graphic display is defined by this command.

The Graphic home address show the left end most upper line.

The relationship of external display RAM address and display position

GH		GH+CL
GH+GA		GH+GA+CL
(GH+GA)+GA		GH+2GA+CL
(GH+2GA)+GA		GH+3GA+CL
GH+(n-1)GA		GH+(n-1)GA+CL

GH : Graphic home address

GA : Graphic area number (columns)

CL : Columns area fixed by hardware. (pin-programmable)

(Example)

Graphic home address : 0000H



**PO WERTIP TECHNOLOGY CORPORATION**

10 DISPLAY DEVICES FOR BETTER ELECTRONIC DESIGN

Graphic area : 0020H  
 MD2=H, MD3=H : 32 columns  
 DUAL =H, MDS=L, MD0=H, MD1=H : 2 lines

0000H	0001H		001EH	001FH
0020H	0021H		003EH	003FH
0040H	0041H		005EH	005FH
0060H	0061H		007EH	007FH
0080H	0081H		009EH	009FH
00A0H	00A1H		00BEH	00BFH
00C0H	00C1H		00DEH	00DFH
00E0H	00E1H		00FEH	00FFH
0100H	0101H		011EH	011FH
0120H	0121H		013EH	013FH
0140H	0141H		015EH	015FH
0160H	0161H		017EH	017FH
0180H	0181H		019EH	019FH
01A0H	01A1H		01BEH	01BFH
01C0H	01C1H		01DEH	01DFH
01E0H	01E1H		01FEH	01FFH

(3)Text area set

The columns of display are defined by the hardware setting. This command can be used to adjust columns of display.

(Example)

LCD size : 20 columns, 4 lines  
 Text home address : 0000H  
 Text area : 0014H  
 MD2=H, MD3=H : 32 columns  
 DUAL=H, MDS=L, MDO=L, MD1=H : 4 lines

0000	0001	.....	0013	0014	.....	001F
0014	0015	.....	0027	0028	.....	0033
0028	0029	.	003B	003C	.	0047
003C	003D	.	004F	0050	.	005B

← LCD →

(4)Graphic area set

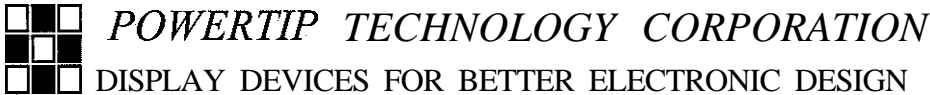

The columns of display are defined by the hardware setting. This command can be used to adjust columns of graphic display.

(Example)

LCD size : 20 columns, 2 lines  
 Text home address : 0000H  
 Text area : 0014H  
 MD2=H, MD3=H : 32 columns  
 DUAL=H, MDS=L, MDD=H, MD1=H : 2 lines

0000	0001	.....	0013	0014	.....	001F
0014	0015	.....	0027	0028	.....	0033
0028	0029	.....	003B	003C	.....	0047
003C	003D	.....	004F	0050	.....	005B
0050	0051	.....	0063	0064	.....	006F
0064	0065	.....	0077	0078	.....	0083
0078	0079	.....	008B	008C	.....	0097
008C	008D	.....	009F	00A0	.....	00AB
00A0	00A1	.....	00B3	00B4	.....	00BF
00B4	00B5	.....	00C7	00C8	.....	00D3
00C8	00C9	.....	00DB	00DC	.....	00E7
00DC	00DD	.....	00EF	00F0	.....	00FD
00F0	00F1	.....	0103	0104	.....	011F
0104	0105	.....	0127	0128	.....	0123
0128	0129	.....	013B	013C	.....	0147
013C	013D	.....	014F	0150	.....	0158

The address in graphic area can be continuous and RAM area can be used without ineffective area, if graphic area is defined the same number as the actual column number of LCD display.

**3.Mode set**

Code	Function	Operand
1000x000	“OR” Mode	
1000x001	“EXOR” Mode	
1000x011	“AND” Mode	
1000x100	“TEXT ATTRIBUTE” Mode	
10000xxx	Internal Character Generator Mode	
10001xxx	External Character Generator Mode	

The display mode is defined by this command. The display mode don't have changed until to send next this command. Logically “OR”, “EXOR”, “AND” of text and graphic display can be displayed. When internal character generator mode is selected, character code 00H-7FH are selected from built-in character generator ROM. The character code 80H~FFH are automatically selected external character generator RAM.

(Example)

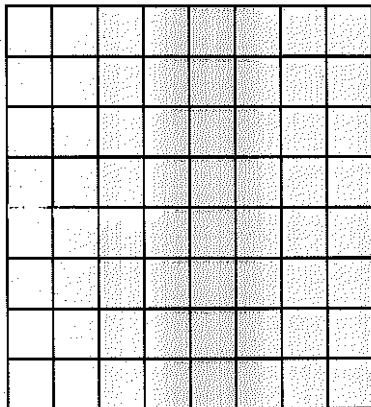

Graphic

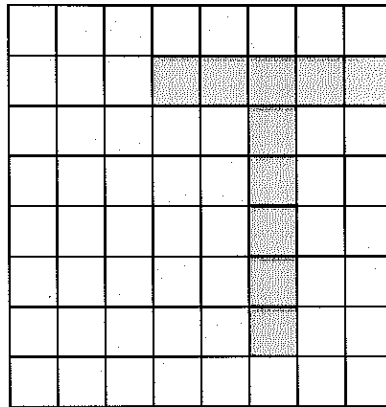

Text

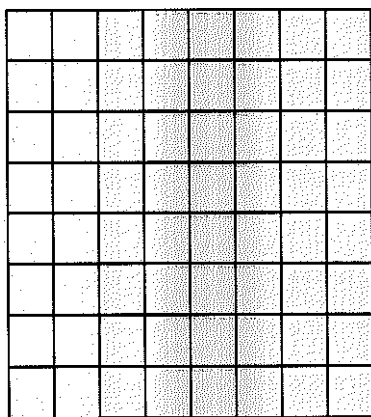

“OR”

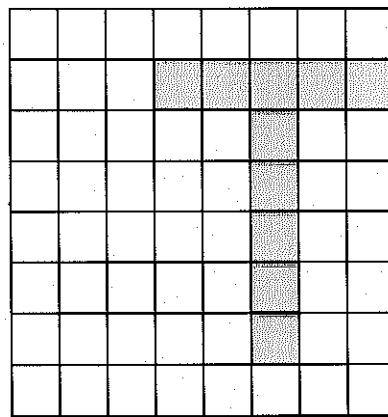

“AND”

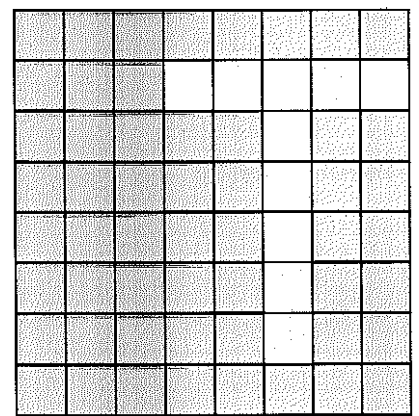

“EXOR”

Note: Only text display is attributed, because attribute data is located in graphic RAM area.

Attribute function

“Reverse display” , “Character blink” and “Inhibit” are called “Attribute”. The attribute data is written in the graphic area defined by Control word set command.

The mode set command selects text display only and graphic display cannot be displayed.

The attribute data of the 1st character in text area is written at the 1st lbyte in graphic area, and attribute data of n-th character is written at the n-th lbyte in graphic area. Attribute function is defined as follow.

Attribute	RAM	lbyte	X	X	X	X	d3	d2	d1	d0
-----------	-----	-------	---	---	---	---	----	----	----	----

d3	d2	d1	d0	Function
0	0	0	0	Normal display
0	1	0	1	Reverse display
0	0	1	1	Inhibit display
1	0	0	0	Blink of normal display
1	1	0	1	Blink of reverse display
1	0	1	1	Blink of inhibit display

X : Don't care

**4.Display mode**

Code	Function	Operand
10010000	Display off	-
1001xx10	Cursor on , blink off	-
1001xx11	Cursor on , blink on	-
100101xx	Text on, graphic off	-
100110xx	Text off, graphic on	-
100111xx	Text on , graphic on	-

1	0	0	1	d3	d2	d1	d0
---	---	---	---	----	----	----	----

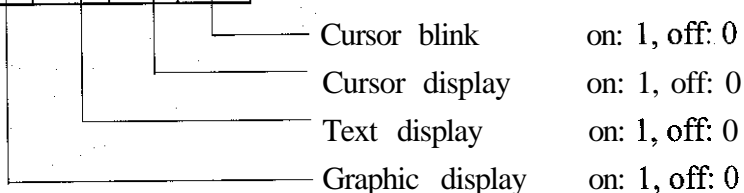

Note: It is necessary to turn on “Text display” and “ Graphic display “ in following case.

- (1) Combination of text/graphic display
- (2) Attribute function



## 5.Cursor pattern select

Code	Function	Operand
10100000	1 line cursor	-
10100001	2 lines cursor	-
10100010	3 lines cursor	-
10100011	4 lines cursor	-
10100100	5 lines cursor	-
10100101	6 lines cursor	-
10100110	7 lines cursor	-
10100111	8 lines cursor	-

When cursor display is ON, this command selects the cursor pattern from 1 line to 8 lines. The cursor address is defined by cursor pointer set command.

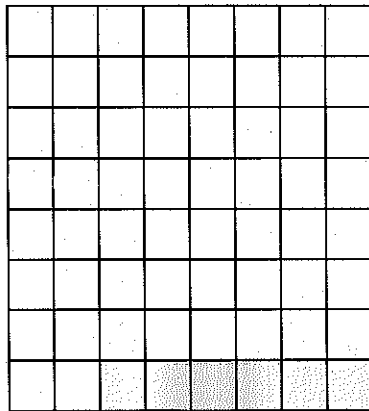

1 line cursor

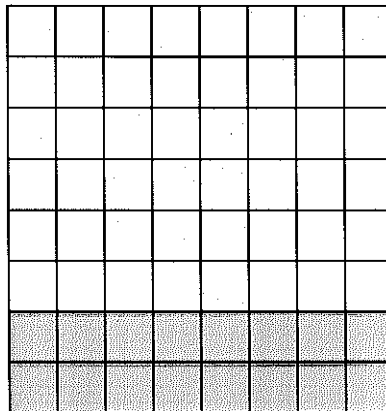

2 lines cursor

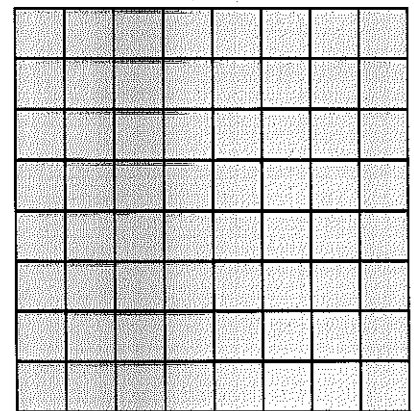

8 lines cursor

## 6.Data auto read/write

Code	Hex.	Function	Operand
10110000	BOH	Data auto write set	
10110001	B1H	Data auto read set	
10110010	B2H	Auto reset	

This command is convenient to send full screen data from external display RAM. After setting auto mode, “Data write (or read)” command is not necessary between each data. “Data write (or read)” command should follow the “Address pointer set” and address pointer is automatically increment by + 1 after each data. After sending (or receiving) all data “Auto reset” is necessary to return normal operation because all data is regarded “Display data” and no command can be accepted in the auto mode.



**POWERTIP TECHNOLOGY CORPORATION**

10 DISPLAY DEVICES FOR BETTER ELECTRONIC DESIGN

Note : Status check for auto mode (STA2, STA should be checked between each data.  
 Auto reset should be performed after checking STA3=1 (STA2=1).  
 Please refer following flow chart.

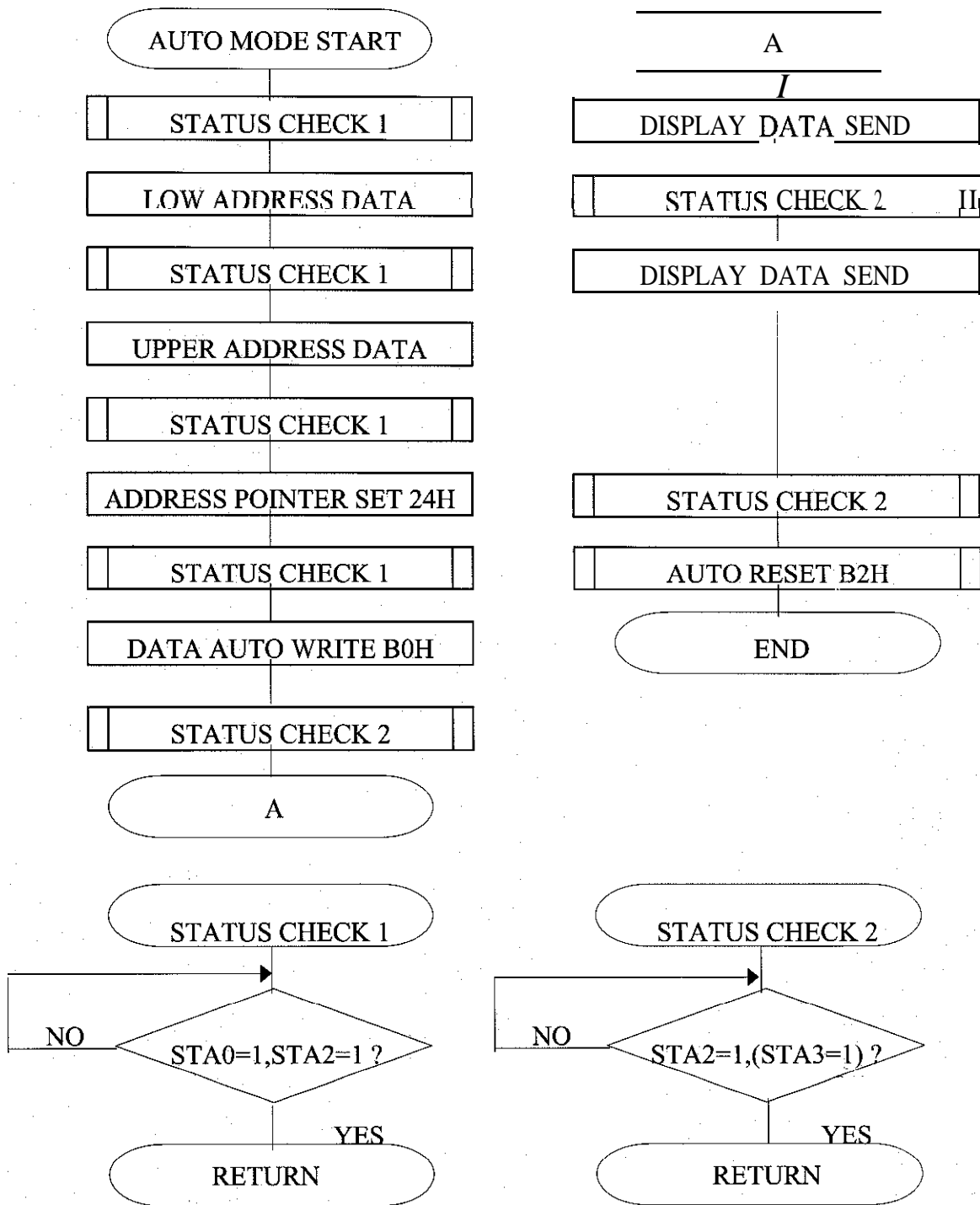

**7.Data read write**

Code	Hex.	Function	Operand
11000000	C0H	Data write and ADP increment	Data
11000001	C1H	Data read and ADP increment	-
11000010	C2H	Data write and ADP decrement	Data
11000011	C3H	Data read and ADP decrement	-
11000100	C4H	Data write and ADP nonvariable	Data
11000101	C5H	Data read and ADP nonvariable	-

This command is used for data write from MPU to external display RAM, and data read from external display RAM to MPU. Data write/data read should be executed after setting address by address pointer set command. Address pointer can be automatically increment or decrement by setting this command.

Note: This command is necessary for each 1 byte data.

Please refer following flow chart.

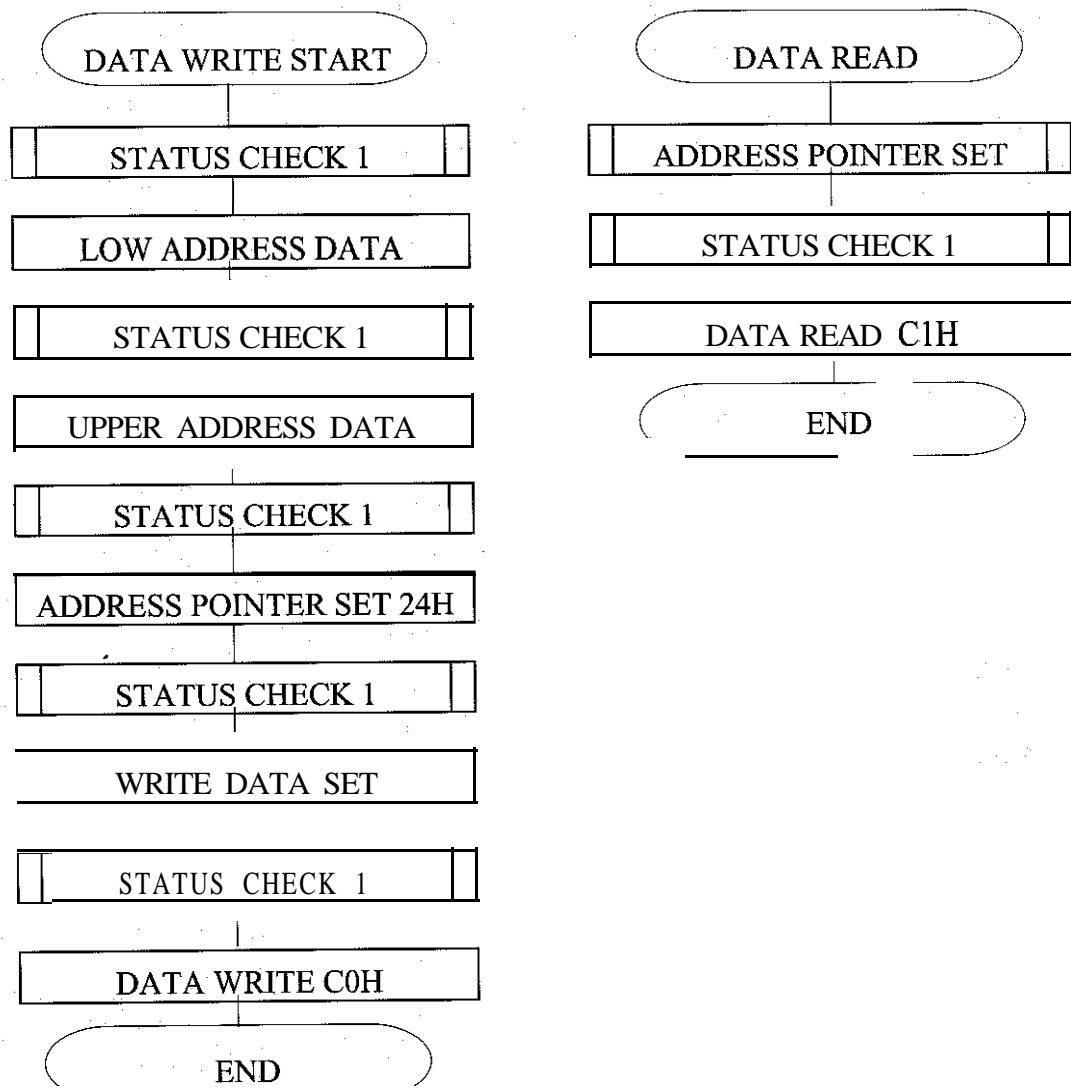

**POWERTIP TECHNOLOGY CORPORATION**

DISPLAY DEVICES FOR BETTER ELECTRONIC DESIGN

**8.Screen peek**

Code	Hex.	Function	Operand
11100000	EOH	screen peek	

read

This command is used to transfer displayed 1 byte data to data stack, and this 1 byte data can be from MPU by data access. The logical combination data of text and graphic display on LCD screen can be read by this command.

The status (STA6) should be checked just after “Screen peek” command. If the address determined by “Address pointer set” command is not in graphic area, this command ignored and status flag (STA6) is set.

Please refer following flow chart.

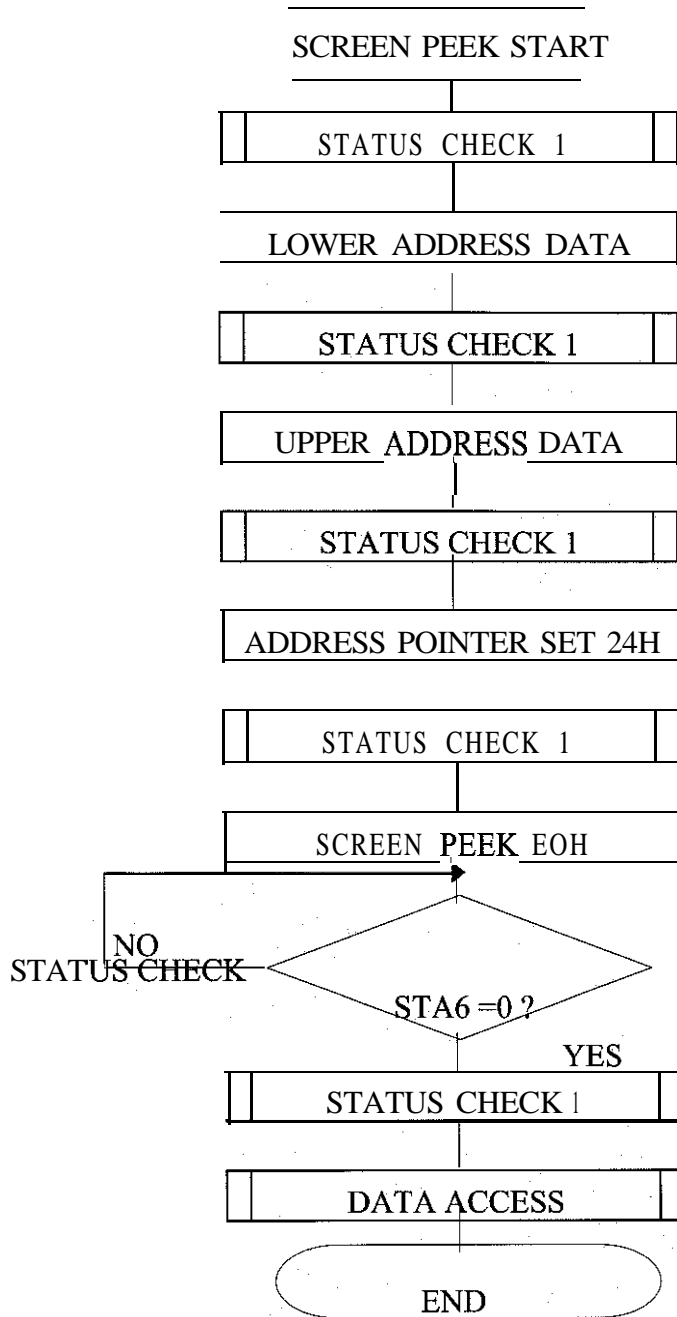

9.Screen copy

Code	Hex.	Function	Operand
11101000	E8H	screen copy	

This command is used to copy displayed 1 line data to graphic area. The start point of 1 line data in the screen is determined by the address pointer.

- Note: (1) In attribute function, this command is invalid.  
 (Because attribute data is in the graphic area.)  
 (2) In case of 2 screen drive, this command is invalid. (Because T693C cannot separate upper screen data and lower screen data.)

Please refer following flow chart.

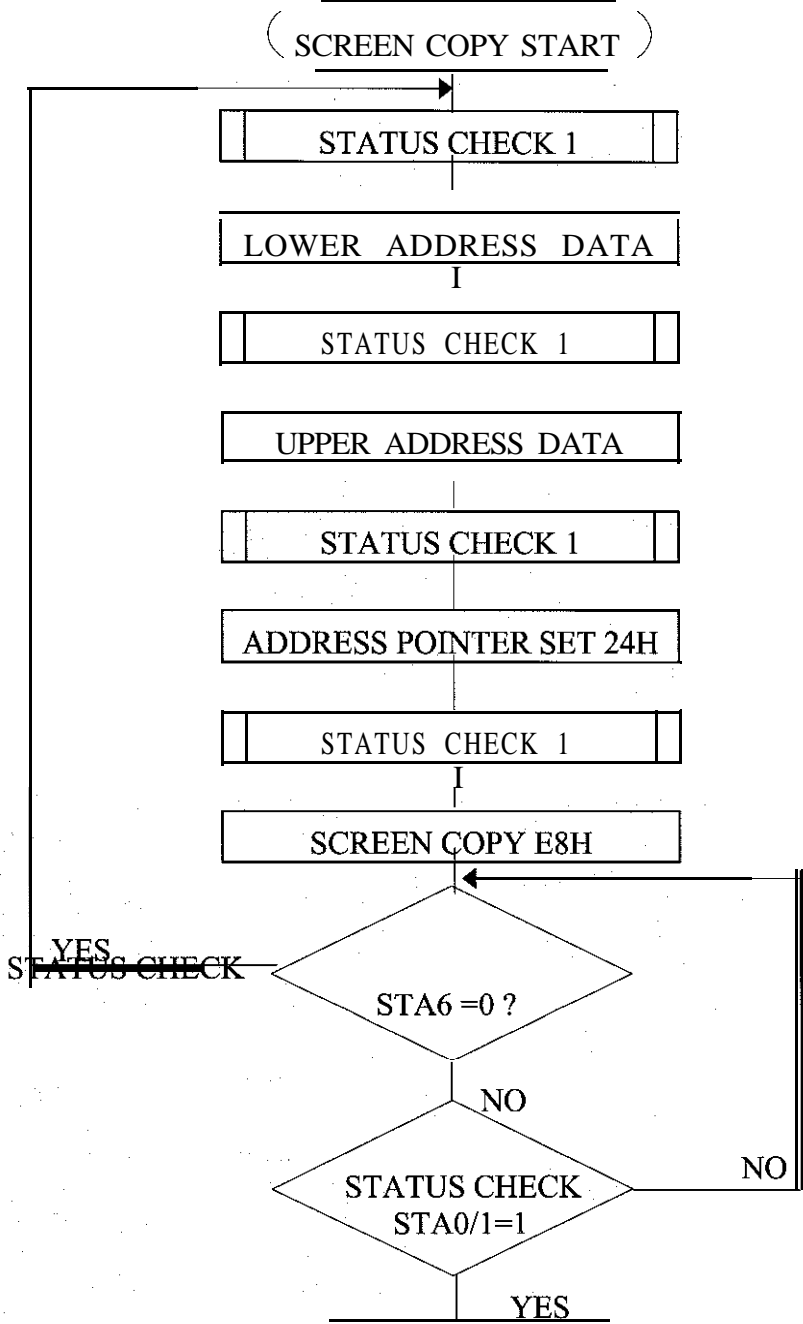

PO WERTIP TECHNOLOGY CORPORATION  
DISPLAY DEVICES FOR BETTER ELECTRONIC DESIGN

END

10.Bit set/reset

Code	Function	Operand
11110xxx	bit reset	-
11111xxx	bit set	-
1111x000	bit 9 (LSB)	-
1111x001	bit 1	-
1111x010	bit 2	-
1111x011	bit 3	-
1111x100	bit 4	-
1111x101	bit 5	-
1111x110	bit 6	-
1111x111	bit 7 (MSB)	-

This command is used to set or reset a bit of 1 byte is specified by address pointer Plural bits in the byte data cannot be set/reset at a time.  
Please refer following flow chart.

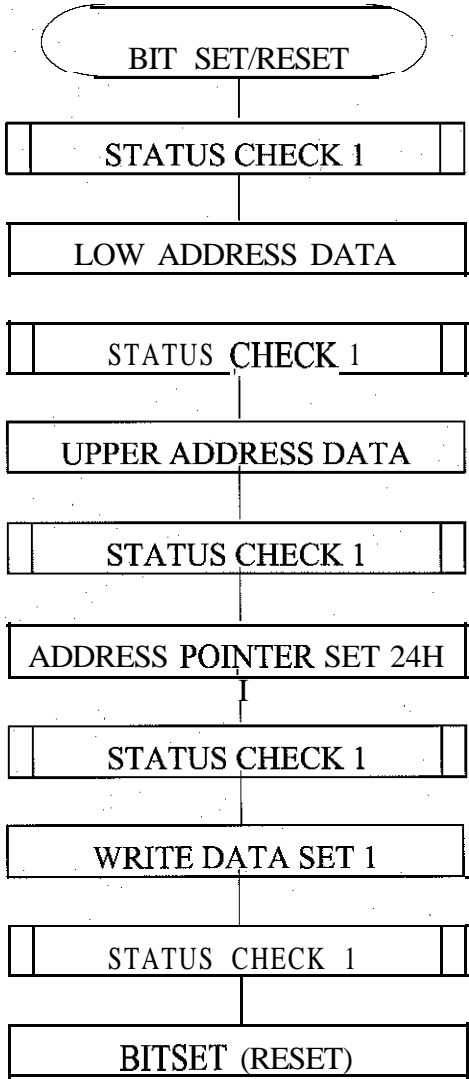

END

•Command list

Command	Code	D1	D2	Function
Register set	00100001	X address	Y address	Cursor pointer set
	00100010	Data	00H	Offset register set
	00100100	Low address	High address	Address pointer set
Control Word Set	01000000	Low address	High address	Text home address set
	01000001	Columns	00H	Text area set
	01000010	Low address	High address	Graphic home address set
	01000011	Columns	00H	Graphic area set
Mode Set	1000x000			"OR" mode
	1000x001			"EXOR" mode
	1000x011			"AND" mode
	1000x100			"Text attribute" mode
	1 0000xxx			"Internal CG ROM mode
	10001xxx			"External CG CG RAM mode
Display Mode	10010000			Display off
	1001xx10			Cursor on, blink off
	1001xx11			Cursor on, blink on
	100101xx			Text on, graphic off
	100110xx			Text off, graphic on
	100111xx			Text on, graphic on
Cursor Pattern Select	10100000			1 line cursor
	10100001			2 lines cursor
	10100010			3 lines cursor
	10100011			4 lines cursor
	10100100			5 lines cursor
	10100101			6 lines cursor
	10100110			7 lines cursor
	10100111			8 lines cursor
Data Auto Read/Write	10110000			Data auto write set
	10110001			Data auto read Set
	10110010			Auto reset
Data Read Write	11000000	Data		Data write and ADP increment
	11000001			Data read and ADP increment
	11000010	Data		Data write and ADP decrement
	11000011			Data read and ADP decrement
	11000100	Data		Data write and ADP nonvariable
	11000101			Data read and ADP nonvariable
Screen Peek	11100000			Screen peek
Screen Copy	11101000			Screen copy
Bit Set/Reset	11110xxx			bit reset
	1111x x x			bit set
	1111x000			bit0 (LSB)
	1111x001			bit1
	1111x010			bit2
	1111x011			bit3
	1111x100			bit4
	1111x101			bit5
	1111x110			bit6
	1111x111			bit7 (MSB)



**POWERTIP TECHNOLOGY CORPORATION**

DISPLAY DEVICES FOR BETTER ELECTRONIC DESIGN

## 2.5 Character Pattern



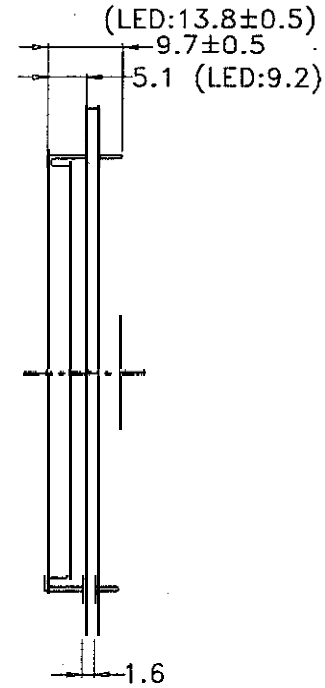
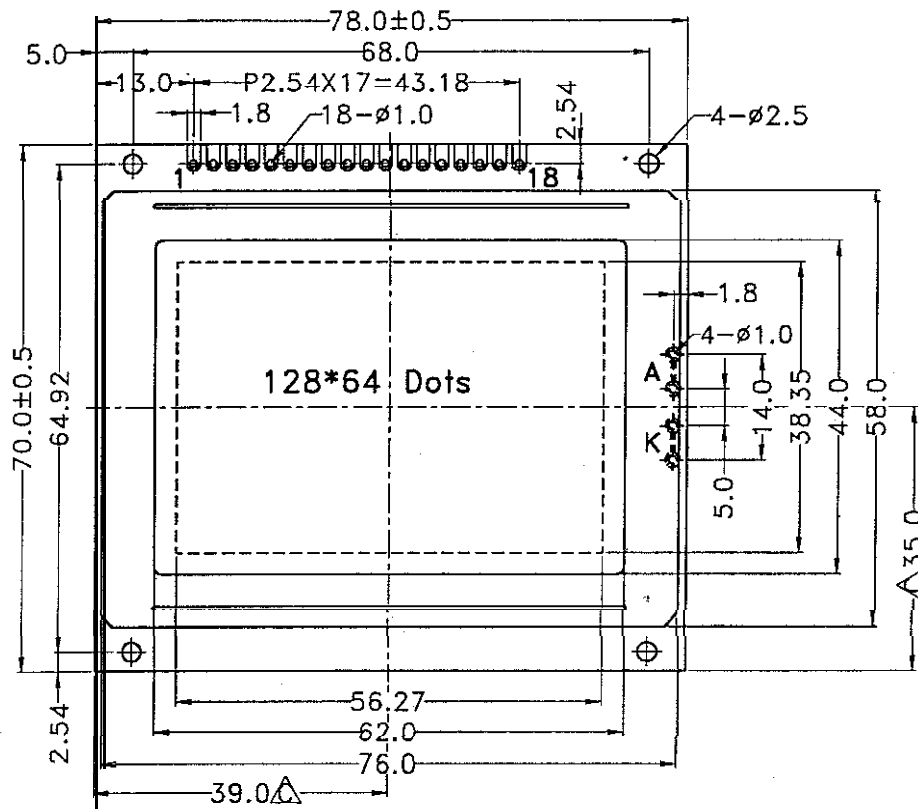

PIN NO.	SIGNAL
1	FG
2	Vss
3	Vdd
4	Vo
5	WR
6	RD
7	CE
8	CD
9	RST
10	DB0
11	DB1
12	DB2
13	DB3
14	DB4
15	DB5
16	DB6
17	DB7
18	FS

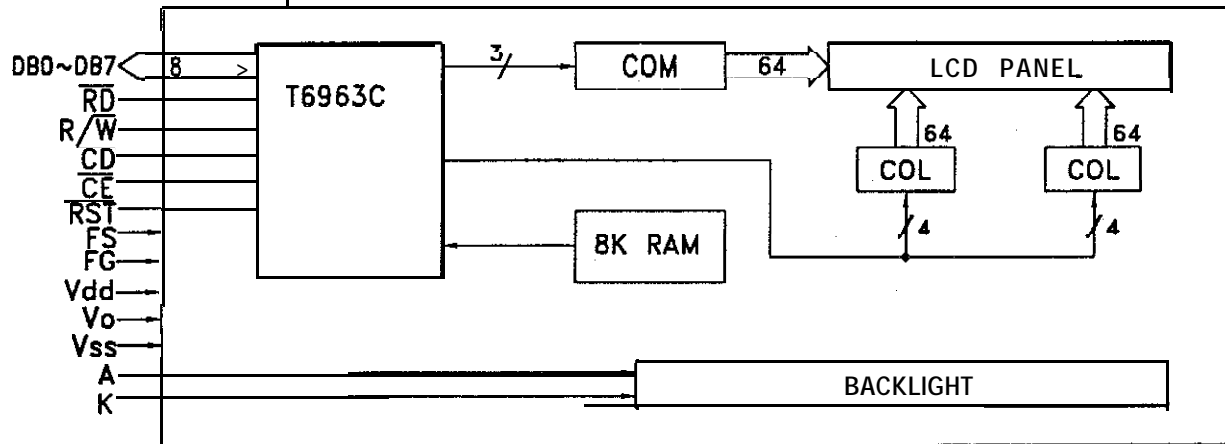

The tolerance unless classified  $\pm 0.3\text{mm}$

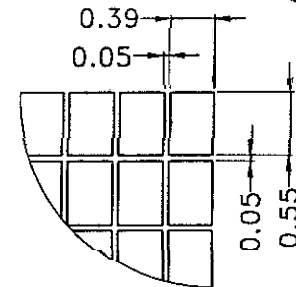

SCALE:15/1

### POWERTIP TECHNOLOGY

SCALE:	MODEL NAME	
1/1	PG 12864-F	
UNIT:	TITLE	
mm	COUNTER DRAWING	
EDI:	PAGE:	DRAWN NO.
C	1/1	PG 95016
APPROVED	CHECKER	DRAWN

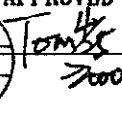

4125-24