

REV	DESCRIPTION	BY DATE	APPRO
A	ECN 2330	DO/07/1/99	[Signature]

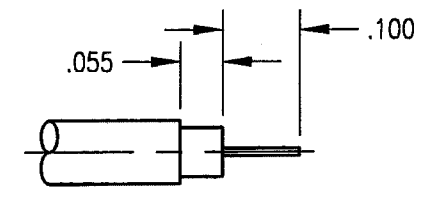
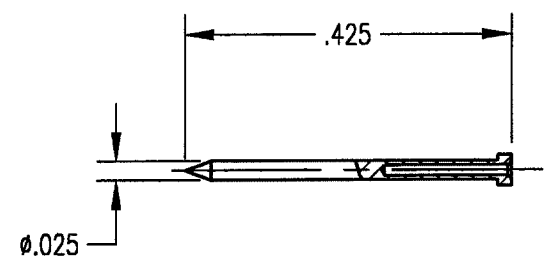
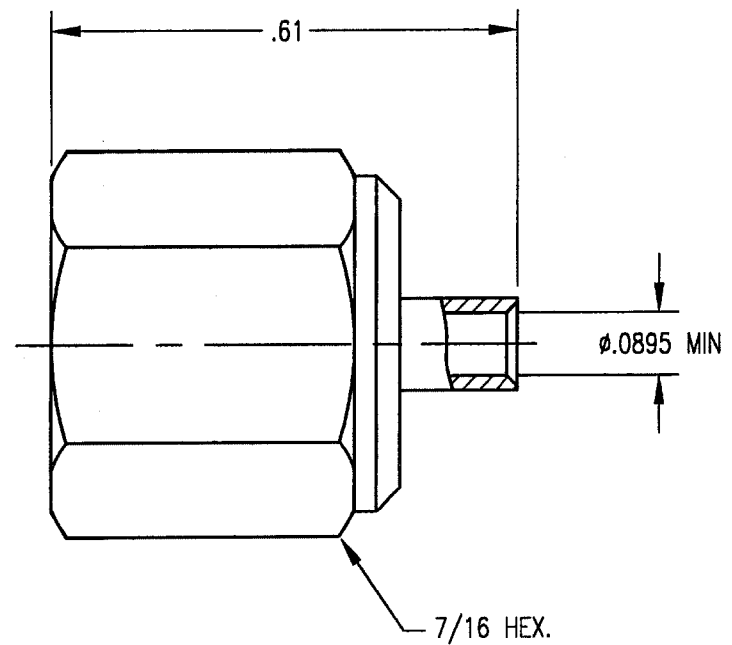

STRIPPING DIM

NOTES:

1. MATERIAL:  
 ALL METAL PARTS: BRASS PER ASTM B16  
 INSULATOR: TEFLON PER ASTM D1710
2. FINISH:  
 BODY AND CONTACT: .000100 MIN SILVER PER QQ-S-365 OVER  
 .000100 COPPER PER MIL-C-14550  
 HEX NUT: .000100 MIN NICKEL PER QQ-N-290
3. DESIGNED FOR USE WITH .086 DIAMETER, 75 OHM SEMI RIGID CABLE OR EQUIVALENT

PER ASME Y14.5M-1994 UNLESS OTHERWISE SPECIFIED: DIMENSIONS ARE IN INCHES OR INCHES/MM TOLERANCES: DECIMALS .XX ± .01/0.254 FRACTIONS XXX ± .005/0.127 ANGLES ± 2' SCALE: 4:1				<b>Litton</b> <b>Winchester Electronics/RETCONN</b> <small>400 Park Road                  Watertown, Connecticut 06795</small>			
<b>CUSTOMER DRAWING</b>				TITLE F PLUG			
DRAWN JMC	DATE 1/18/99	CHECKED KJT	DATE 1/18/99	APPROVED JED	DATE 1/18/99	APPROVED JED	DATE 1/18/99
<b>A</b>				060-500-0859S		SHT. 1 OF 1	REV. A