

Packaging Information / Reference Pattern Layout Dimensions

● USP-10

Unit: mm

■ Packaging Information

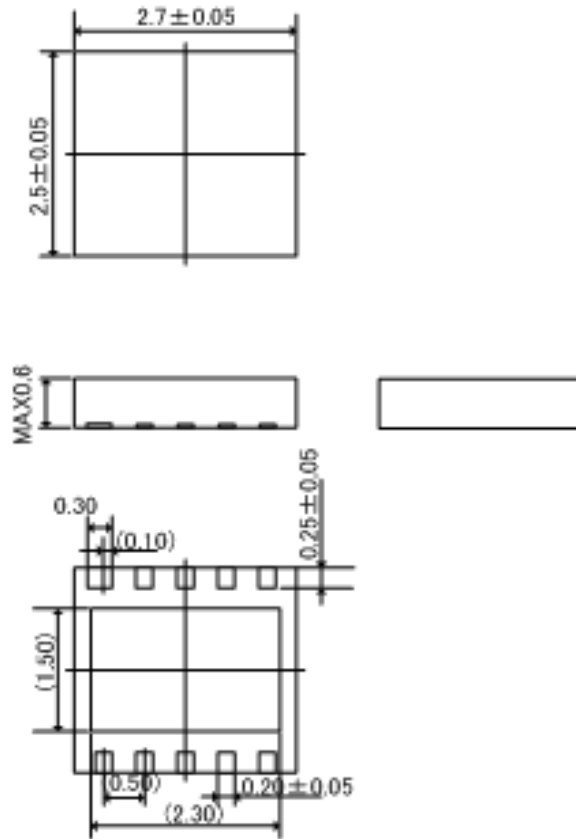

■ Reference Pattern Layout Dimension

Note : reference metal mask design

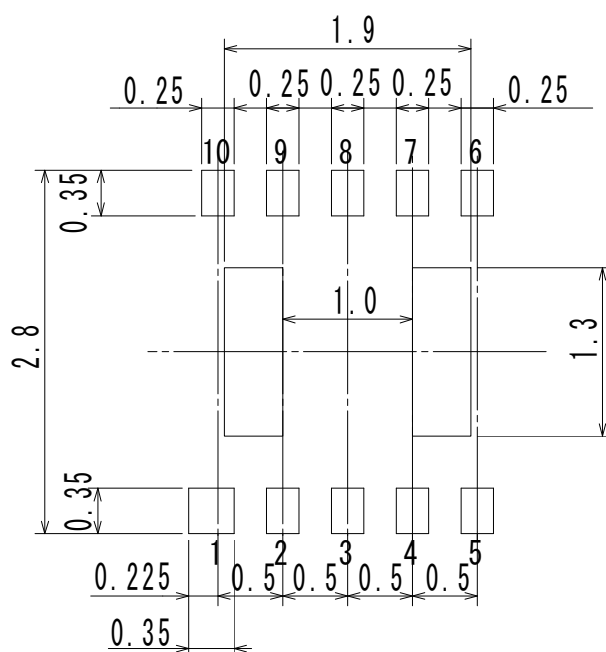
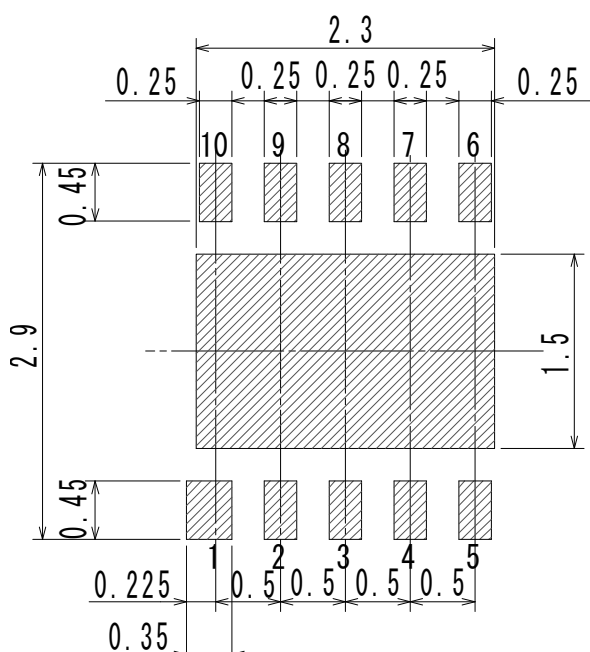

テーピング仕様 / Taping Specifications

USP-10

●リール/Reel

Unit: mm

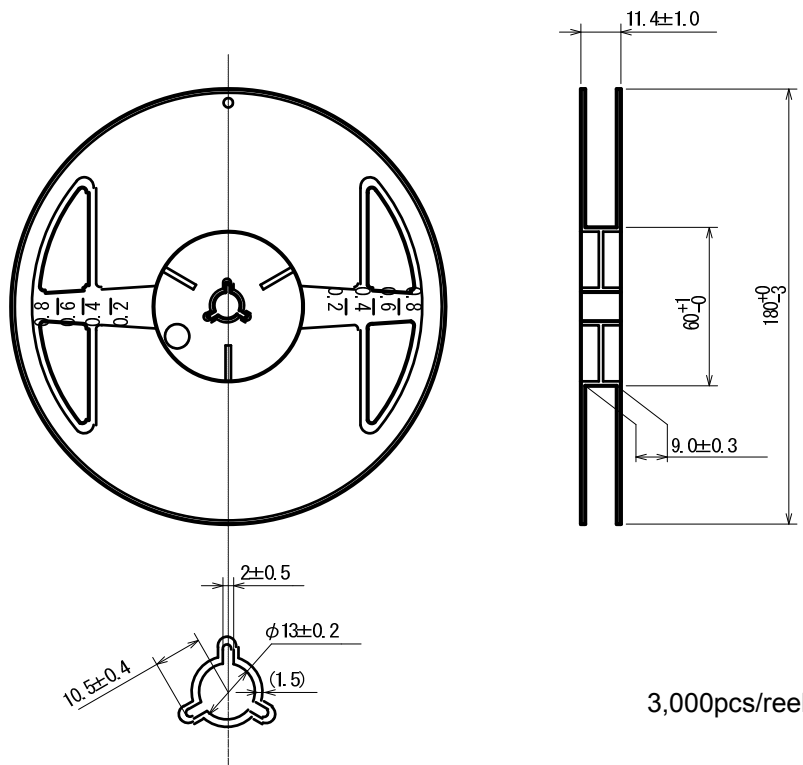

3,000pcs/reel

●テーピング仕様/Taping Specifications

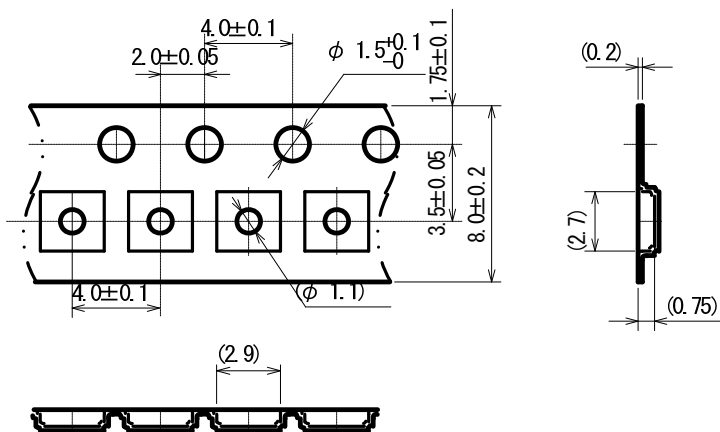

direction of feed

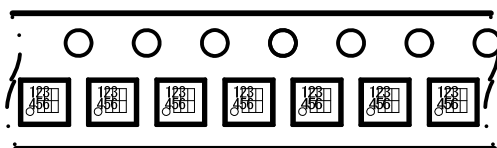

R Type : [Device orientation : Right]

Standard feed

USP-10 構造図

USP-10 Perspective

RoHS対応品
RoHS Compliance

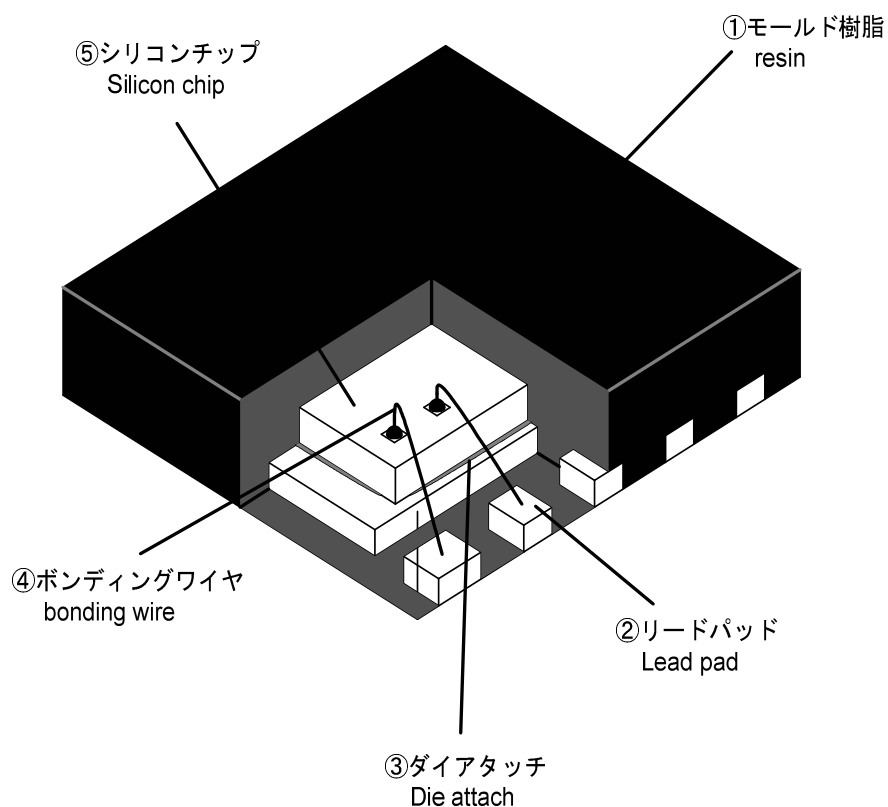

項目 item	材料 material	備考 Note
① モールド樹脂 resin	エポキシ樹脂 Epoxy resin	難燃グレード/Flammability rating UL94V-0
② リードパッド Lead padd	ニッケル Nickel	
端子処理 outer pad plating	鉛フリーはんだメッキ Lead(Pb) free solder plating	端子側面は除く Except the side of the terminals.
③ ダイペースト die paste	銀入りエポキシ Silver filled Epoxy	
④ ボンディングワイヤ Bonding wire	Au	
⑤ シリコンチップ Si	Si	

捺印表示 marking	レーザー laser marking
-----------------	-----------------------