

PANEL THICKNESS	X dimension
0.75-1.25 [.030-.0491]	19.2-.01 [.7561]
1.25-2.0 [.049-.079]	19.4-.01 [.7641]
2.0-3.0 [.079-.118]	19.8-.01 [.7801]

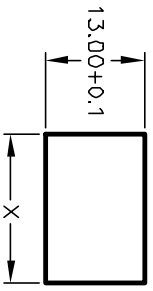

PANEL CUTOUT
NOT TO SCALE

SWITCH FUNCTION	
PDS, 1	PDS, 2
DN	OFF
1-1a	DPEN

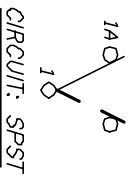

NOTES:

- ALL DIMENSIONS IN MM [INCH]
- GENERAL TOLERANCE: X,X=±0.4
X,XX=±0.25
- TERMINAL NUMBERS FOR REF ONLY
- RATING: 15A @ 125VAC OR 6A @ 250VAC
- MATERIALS: (TERMINALS) SILVER PLATED COPPER
(CONTACTS) COIN SILVER, SILVER PLATED.
- CONTACT RESISTANCE: <20 Mega
- ELECTRICAL LIFE: 10,000 cycles
- INSULATION RESISTANCE: >1000 Mega
- DIELECTRIC STRENGTH: >1500V 1 minute
- OPERATING TEMP. RANGE: -25°C to +85°C

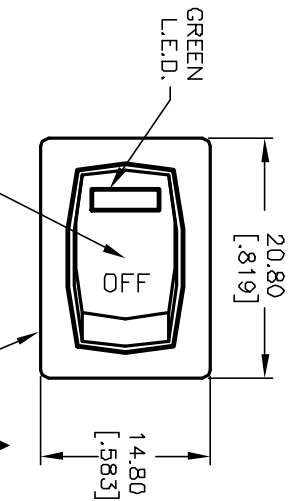

BLACK ACTUATOR
BLACK HOUSING

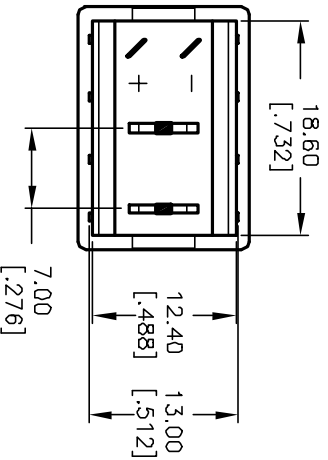
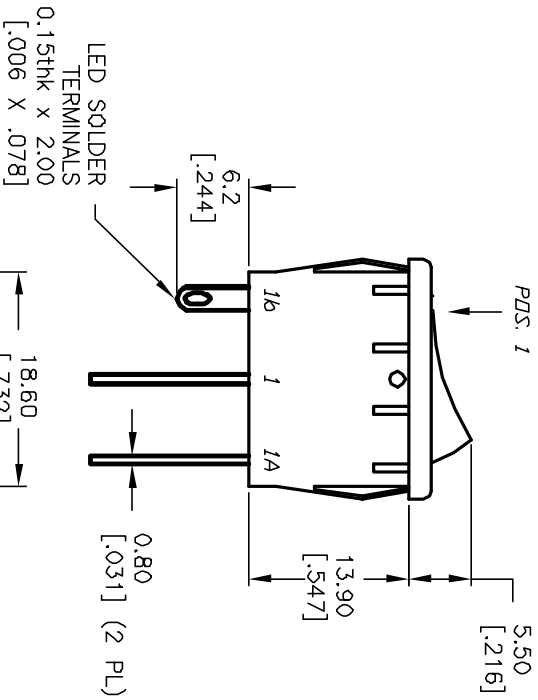

GREEN L.E.D

PARAMETERS	SYMBOL	MAX. TYP.	UNITS
POWER DISSIPATION	P _d	80	mW
AVERAGE FORWARD CURRENT	I _{AF}	--	mA
PEAK FORWARD CURRENT	I _{PF}	100	mA
REVERSE VOLTAGE	V _R	5	V
FORWARD VOLTAGE	V _F	2.6	V
REVERSE CURRENT	I _R	100	µA
EMISSION WAVELENGTH	λ _p	570	nm
LUMINOUS INTENSITY	I _v	30	mcd

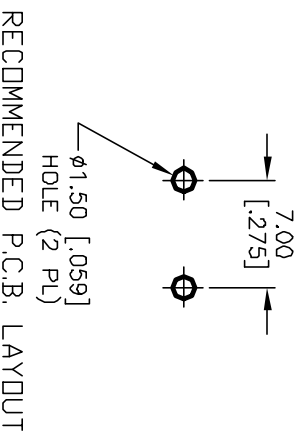
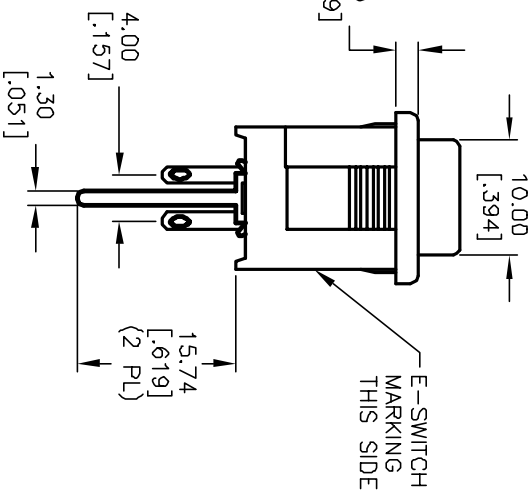

E-SWITCH®

REV.	ECN No.	DESCRIPTION	DATE	CHKD	TITLE	SCALE	DATE	DR	DWG	REV
A	12710	WAS 2000536	1/10/02	CB	R1966A BLK BLK IP GRN	1.5:1	1/8/03	CB	M300002	A

THE INFORMATION CONTAINED IN THIS DOCUMENT IS PROPRIETARY TO E-SWITCH AND IS NOT TO BE COPIED OR TRANSFERRED