

SAMSUNG

LASER PRINTER

ML-1700 Series

ML-1510

ML-1710

ML-1750

SERVICE *Manual*

LASER PRINTER

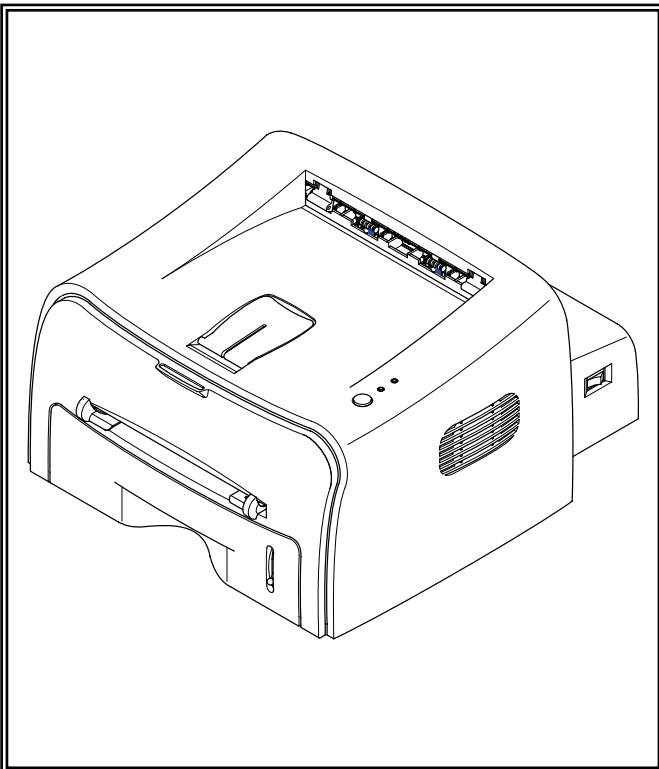

CONTENTS

1. Precautions
2. Reference Information
3. Specifications
4. Summary of product
5. Disassembly and Reassembly
6. Alignment and Adjustments
7. Troubleshooting
8. Exploded Views and Parts List
9. Block Diagram
10. Connection Diagram
11. Schematic Diagram

1. Precautions

The cautions in the below are items needed to keep in mind when maintaining and servicing. Please read carefully and keep the contents in mind to prevent accidents while servicing and to prevent that the machine gets damage.

1.1 Warning for safety.

(1) Request the service by qualified service person.

The service for this machine must be performed by a service person who took the additional education of this field.

It is dangerous if unqualified service person or user tries to fix the machine.

(2) Do not rebuild it discretionary.

Do not attach or change parts discretionary. Do not disassemble, fix, and rebuilt it. If do, printer will abnormally work and electric shock or a fire can be occurred.

(3) Laser Safety Statement

The Printer is certified in the U.S. to conform to the requirements of DHHS 21 CFR, chapter 1 Subchapter J for Class 1(1) laser products, and elsewhere, is certified as a Class I laser product conforming to the requirements of IEC 825.

Class I laser products are not considered to be hazardous. The laser system and printer are designed so there is never any human access to laser radiation above a Class I level during normal operation, user maintenance, or prescribed service condition.

Warning >> Never operate or service the printer with the protective cover removed from Laser/Scanner assembly. The reflected beam, although invisible, can damage your eyes. When using this product, these basic safety precautions should always be followed to reduce risk of fire, electric shock, and injury to persons.



CAUTION - INVISIBLE LASER RADIATION
WHEN THIS COVER OPEN.
DO NOT OPEN THIS COVER.

VORSICHT - UNSICHTBARE LASERSTRAHLUNG,
WENN ABDECKUNG GEFFNET.
NICHT DEM STRAHL AUSSETZEN.

ATTENTION - RAYONNEMENT LASER INVISIBLE EN CAS
D'OUVERTURE. EXPOSITION DANGEREUSE
AU FAISCEAU.

ATTENZIONE - RADIAZIONE LASER INVISIBLE IN CASO DI
APERTURA. EVITARE L'ESPOSIZIONE AL
FASCIO.

PRECAUCION - RADIACION LASER IVISIBLE CUANDO SE ABRE.
EVITAR EXPONERSE AL RAYO.

ADVARSEL - USYNLIG LASERSTRÅLNING VED ÅBNING, NÅR
SIKKERHEDSBRYDERE ER UDE AF FUNKTION.
UNDG. UDSÆTTELSE FOR STRÅLNING.

ADVARSEL - USYNLIG LASERSTRÅLNING NÅR DEKSEL
ÅPNES. STIRR IKKE INN I STRÅLEN.
UNNG EKSPONERING FOR STRÅLEN.

VARNING - OSYNLIG LASERSTRÅLNING NÅR DENNA DEL
ÅPPNAD OCH SPÅRRENS RÅR KOPPLAD.
BETRAKTA EJ STRÅLEN. STRÅLEN ÅR FARLIG.

VARO! - AVATTAESSA JA SUOJALUKITUS OHITETTAESSA
OLET ALTTIINA N KYM TT M LLE LASER-
S TEILYLLE L KATSO S TEESEEN.

注意 - 严禁揭开此盖, 以免激光泄露灼伤

주의 - 이 덮개를 열면 레이저광에 노출될 수 있으므로
주의하십시오.

1.2 Caution for safety

1.2.1 Precaution related noxious material

The toner in a printer cartridge contains a chemical material, which might harm human body if it is swallowed.

Please keep children out of the toner cartridge.

1.2.2 Precaution related electric shock or fire

It is possible to get electric shock or burn by fire if you don't follow the instructions of the manual.

- (1) Use exact voltage. Please do use an exact voltage and wall socket. If not, a fire or an electric leakage can be caused.
- (2) Use authorized power code. Do use the power code supplied with PRINTER. A fire can be occurred when over current flows in the power code.
- (3) Do not insert many codes in an outlet. If do, a fire can be occurred due to flow over current in an outlet.
- (4) Do not put water or extraneous matter in the PRINTER. Please do not put water, other liquid, pin, clip, etc. It can cause a fire, electric shock, or malfunction. If it is happened, turn off the power and remove the power plug from outlet immediately.
- (5) Do not touch the power plug with wet hand. When servicing, do remove the power plug from outlet. And do not insert or take off it with wet hand. Electric shock can be occurred.
- (6) Caution when inserting or taking off the power plug. The power plug has to be inserted completely. If not, a fire can be caused due to poor contact. When taking off the power plug, do grip the plug and take it off. If grip the line and pull over, it could be damaged. A fire or electric shock could cause.
- (7) Management of power code. Do not bend, twist, or bind it and place other materials on it. Also, do not fix it with staples. If the power code gets damage, a fire or electric shock can be caused. A damaged power code must be replaced immediately. Do not repair the damaged part and reuse it. A repaired part with plastic tape can be occurred a fire or electric shock. Do not spread chemicals on the power code. Do not spread insecticide on the power code. A fire or electric shock can be occurred due to thinner(weak) cover of the power code.
- (8) Check whether the power outlet and the power plug are damaged, pressed, chopped, or blazing fire or not. When such inferiorities are found, repair it immediately. Do not make it pressed or chopped when moving the machine.
- (9) Caution when thundering, and being flash of lightening. It causes a fire or electric shock. Take the power plug off when thundering. Do not touch cable and device when thundering and being flash of lightening.
- (10) Do avoid the place where is moisture or has dust. Do not install the printer in where have lots of dust or around humidifier. A fire can be occurred. A plug part need to clean well with dried fabric to remove dust. If water drops are dripped on the place covered with dust, a fire can be occurred.
- (11) Avoid direct sunlight. Do not install the printer near to window where directly contacts to the sunlight. If the machine contacts sunlight long time, the machine cannot work properly because inner temperature of the machine is getting higher. A fire can be caused.
- (12) Turn off the power and take off the plug when a smoke, strange smell, or sound from the machine. If you keep using it, a fire can be occurred.
- (13) Do not insert steel or metal piece inside/outside of the machine. Do not put steel or metal piece into a ventilator. An electric shock could be happened.

1.2.3 Precaution related handling the machine.

If you ignore this information, you could get harm and machine could be damaged.

- (1) Do not install it on the different levels, or slanted floor.
Please confirm whether it is balanced or not after installation. If it is unbalanced, an accident can be happened due to the machine fell over.
- (2) Be careful not to insert a finger or hair in the rotating unit.
Be careful not to insert a finger of hair in the rotating unit (motor, fan, paper feeding part, etc) while the machine is operating. Once it happens, you could harm.
- (3) Do not place a pot contains water/chemical or small metals. If those are got into the inner side of machine, a fire or electric shock can be occurred.
- (4) Do not install it in where lots of moisture or dust exists or where raindrop reaches. A fire or electric shock can be caused.
- (5) Do not place a candlelight, burning cigarette, and etc. on the machine. Do not install it near to heater. A fire can be occurred.

1.2.4 Precaution when assembly/disassembly

When replace parts, do it very carefully. Do memorize the location of each cable before replace parts for reconnecting it afterwards. Do memorize. Please perform the below before replace or disassembly the parts.

- (1) Check the contents stored in the memory. All the information will be erased after replace main board.
The information needed to keep has to be written down.
- (2) Before servicing or replacing electric parts, take off a plug.
- (3) Take off printer cables and power code connected to printer.
- (4) Do use formal parts and same standardized goods when replacing parts. Must check the product name, part code, rated voltage, rated current, operating temperature, etc.
- (5) Do not give an over-force when release or tighten up the plastic parts.
- (6) Be careful not to drop the small parts such as screws in the printer.
- (7) Be careful not to change the location of small parts such as screws when assembling and disassembling.
- (8) Do remove dust or foreign matters completely to prevent fire of tracking, short, or etc.
- (9) After finished repair, check the assembling state whether it is same as before the repair or not.

1.3 ESD Precautions

Certain semiconductor devices can be easily damaged by static electricity. Such components are commonly called “Electrostatically Sensitive (ES) Devices”, or ESDs. Examples of typical ESDs are: integrated circuits, some field effect transistors, and semiconductor “chip” components.

The techniques outlined below should be followed to help reduce the incidence of component damage caused by static electricity.

Caution >>Be sure no power is applied to the chassis or circuit, and observe all other safety precautions.

1. Immediately before handling a semiconductor component or semiconductor-equipped assembly, drain off any electrostatic charge on your body by touching a known earth ground. Alternatively, employ a commercially available wrist strap device, which should be removed for your personal safety reasons prior to applying power to the unit under test.
2. After removing an electrical assembly equipped with ESDs, place the assembly on a conductive surface, such as aluminum or copper foil, or conductive foam, to prevent electrostatic charge buildup in the vicinity of the assembly.
3. Use only a grounded tip soldering iron to solder or desolder ESDs.
4. Use only an “anti-static” solder removal device. Some solder removal devices not classified as “anti-static” can generate electrical charges sufficient to damage ESDs.
5. Do not use Freon-propelled chemicals. When sprayed, these can generate electrical charges sufficient to damage ESDs.
6. Do not remove a replacement ESD from its protective packaging until immediately before installing it. Most replacement ESDs are packaged with all leads shorted together by conductive foam, aluminum foil, or a comparable conductive material.
7. Immediately before removing the protective shorting material from the leads of a replacement ESD, touch the protective material to the chassis or circuit assembly into which the device will be installed.
8. Maintain continuous electrical contact between the ESD and the assembly into which it will be installed, until completely plugged or soldered into the circuit.
9. Minimize bodily motions when handling unpackaged replacement ESDs. Normal motions, such as the brushing together of clothing fabric and lifting one’s foot from a carpeted floor, can generate static electricity sufficient to damage an ESD.

2. Reference Information

This chapter describes the reference information for applying this training manual, and it is consisted of the tool list, the abbreviation table, the outline of model, and so on.

2.1 Tool for Troubleshooting

The following tools are recommended for safe and smooth troubleshooting described in this service manual.

1 DCU(Diagnostic Control Unit)

Standard : Test equipment to diagnose the Laser printer supplied by Samsung Electronics.

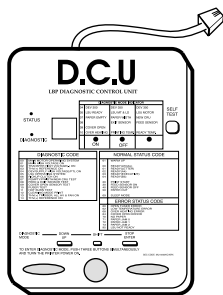

4 Driver

Standard : "-" type, "+" type (M3 long, M3 short, M2 long, M2 short).

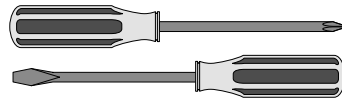

5 Pinset

Standard : For general home use, small type.



2 DVM(Digital Volt Meter)

Standard : Indicates more than 3 digits.

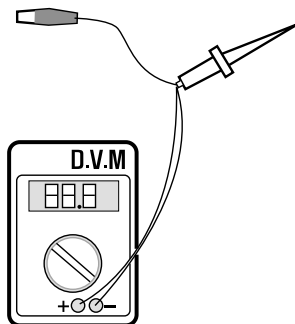

6 Cotton Swab

Standard : For general home use, for medical service



7 Cleaning Equipments a IPA(Isopropyl Alcohol)dry cloth or a soft stuff neutral detergent

3 Electronic Scale

Standard : Equipment to check the weight of consumables(toner cartridge) supplied by Samsung Electronics. (The gram unit can be measured.)

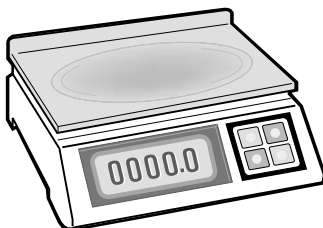

8 Software(Driver) installation CD ROM

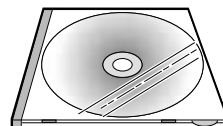

Mind your hands not to be touched when you disassemble and reassemble PBA ASS'Y, such as the main board, SMPS, HVPS.

2.2 Acronyms and Abbreviations

The table in the below explains abbreviations used in this service manual.

The contents of this service manual are declared with abbreviations in many parts. Please refer to the table.

AC	Alternating Current
ASIC	Application Specific Integrated Circuit
ASSY	assembly
BIOS	Basic Input Output System
CMOS	Complementary Metal Oxide Semiconductor
CN	connector
CON	connector
CPU	Central Processing Unit
dB	decibel
dbA	decibelampere
dBm	decibel milliwatt
DC	direct current
DCU	Diagnostic Control Unit
DPI	Dot Per Inch
DRAM	Dynamic Random Access Memory
DVM	Digital Voltmeter
ECP	Enhanced Capability Port
EEPROM	Electrically Erasable Programmable Read Only Memory
EMI	Electro Magnetic Interference
EP	electrophotographic
EPP	Enhanced Parallel Port
F/W	firmware
GDI	graphics device interface
GND	ground
HBP	Host Based Printing
HDD	Hard Disk Drive
HV	high voltage
HVPS	High Voltage Power Supply
I/F	interface
I/O	Input and Output
IC	integrated circuit
IDE	Intelligent Drive electronics or Imbedded Drive Electronics
IEEE	institute of Electrical and Electronics Engineers. Inc
IPA	Isopropyl Alcohol
IPM	Images Per Minute
LAN	local area network
lb	pound(s)
LBP	Laser Beam Printer
LCD	Liquid Crystal Display
LED	Light Emitting Diode
LSU	Laser Scanning Unit
MB	megabyte
MHz	megahertz
NVRAM	nonvolatile random access memory
OPC	Organic Photo Conductor
PBA	Printed Board Assembly
PCL	Printer Command Language , Printer Control Language
PDL	Page Description Language
PPM	Page Per Minute
PTL	Per-Transfer Lamp
Q [∅] ty	quantity
RAM	Random Access Memory
ROM	Read Only Memory
SCF	Second Cassette Feeder
SMPS	Switching Mode Power Supply
SPGP	Samsung Printer Graphic Processor
SPL	Samsung Printer Language
Spool	Simultaneous Peripheral Operation Online
SW	switch
sync	synchronous or synchronization
USB	Universal Serial Bus

3. Specifications

3.1 General Specifications

ITEM	DESCRIPTION
Print Technology	Non-impact Electro-photographic Printing
Developing system	Non-Magnetic, Mono-Component Developing System
Print Speed ⁽¹⁾	16 PPM : A4 size , 5% Character pattern (ML-1510 : 14PPM) 17 PPM : Letter size , 5% Character pattern (ML-1510 : 15PPM)
Resolution	ML-1710 / ML-1510 : True 600 X 600 DPI ML-1750 : 1200 X 600 DPI
Source of Light	Laser diode (LSU : Laser Scanner Unit)
Warm-Up Time	Power-on boot : 30 seconds or less
First Print Out Time	Less than 11 seconds (Ready to 1st page out)
Media Size	75 X 125 (3" X 5") mm to 216 X 356 (8.5" X 14")mm
Media Thickness	16 ~ 24 lb
Dimension(W X D X H)	348 X 355 X 193mm / 13.7 X 14 X 7.6 inch
Weight	Net : 7 Kg /15.4 lb Gross : 9.5 Kg (Max.)
Acoustic Noise ⁽¹⁾	Stand by : Less than 35 dB Printing: Less than 50 dB
Power save mode	Available
Toner save mode	Available
Machine Life	120,000 Sheets
Periodic Replacing Parts ⁽²⁾	Pick Up Roller : 60,000 Sheets Feed Roller : 60,000 Sheets Transfer Roller: 60,000 Sheets Fuser Assembly : 60,000 Sheets

(1) For measuring the printing speed, count the papers which outputted within one minute from when the second page starts to be printed. (A4, 5% character pattern standard)

(2) The life span of the consumption parts can be checked by printing the demo page or the system list. (Refer to the 6.3 Receive the service information)

3.2 Controller Specification

ITEM	DESCRIPTION	
	ML-1710 /ML-1510	ML-1750
Processor(CPU)	Samsung Jupiter4 90MHz	Samsung SPGPm 166MHz
OS Compatibility ⁽¹⁾	Win 98x/NT4.0/ME/2000/XP, Various Linux OS,Mac(Mac OS 8.6 ↑)	
Memory	FLASH ROM(PROGRAM) : 0.5MB flash	FLASH ROM(PROGRAM) : 0.5MB flash
	RAM : 8MB	
	EEPROM(NVRAM) : 512byte	
Emulation	SPL(Samsung Printer Language)	PCL6, IBMProPrinter, EPSON
Interface	USB 1.1	USB - USB 2.0 - 12 Mbps 1 port Parallel : IEEE 1284 - Modes supported : Compatible,Nibble,Byte,ECP External Network Adaptor(Optional)
Interface switching	Automatic	
Interface time-out	5min(Max.)	
Font	Windows Font	45 Scalable, 1 Bitmap

(1) The SPL series model is USB exclusive use, so it supports the environment beyond the WIN 98.

3.3 Electrical Specification

ITEM	DESCRIPTION	
Input Voltage	Nominal input voltage	200-240 VAC / 100~127VAC
	Input voltage range	189-264 VAC/ 90~132VAC
	Nominal frequency	50/60 Hz
	Frequency tolerance	+3Hz
Power Consumption	Printing : 280W Avg or less	Power Save : 10W Avg or less

3-4 Environmental Range

ITEM	OPERATING	STORAGE
Temperature	10~32 °C(50-90 oF)	-20~40 °C (-4~104 oF)
Humidity	20~80%RH	10~80%RH

3.5 TONER Cartridge (Developer)

ITEM	DESCRIPTION	REMARK
Life span	Starter: 1,000 sheets (3,000 sheets For China)	IDC 5% pattern
	Running : 3,000 sheets	
Developing	Non-magnetic Mono Component Contact Developing	
Charging	Conductive Roller Charging	
Toner checking sensor	Not Available	
Ozone	0.1PPM or less	8 hours
Style	Single cartridge	

2-Paper Handling Specifications

Please refer to "Paper Specifications" on user guide

- Input Paper Size

PAPER	DIMENSIONS	WEIGHT
A4	210 X 297 mm	60 to 90 g/m ² bond(16 to 24 lb)
Letter	216 X 279(8.5 X 11")	
Legal(Legal14")	216 X 356(8.5 X14")	
JIS B5	182 X257mm (7.2 X 10")	
Folio(Legal13")	216 X 330mm (8.5 X 13")	
Minimum size (Custom)	76 X 127mm (3 X 5")	60 to 163 g/m ² bond(16 to 43 lb)
Maximum size (Custom)	216 X 356mm (8.5 X 14")	
Transparency(OHP)	Same minimum and maximum sizes as listed above	Thickness:
Label paper		0.10 X 0.14 mm (0.0039 X 0.0055")
Envelopes		Up to 90 g/m ² bond(16 to 24 lb)

- Input capacity

Cassette: 250 sheets
Manual : 1 sheet

- Output capacity

Face Down : 50 sheets(20lb)
Face Up : 1 sheet(OHP, Label, Cut Sheet, Envelope)

MEMO

4. Summary of Product

This chapter describes the functions and operating principal of the main component.

4.1 Printer Components

4.1.1 Front View

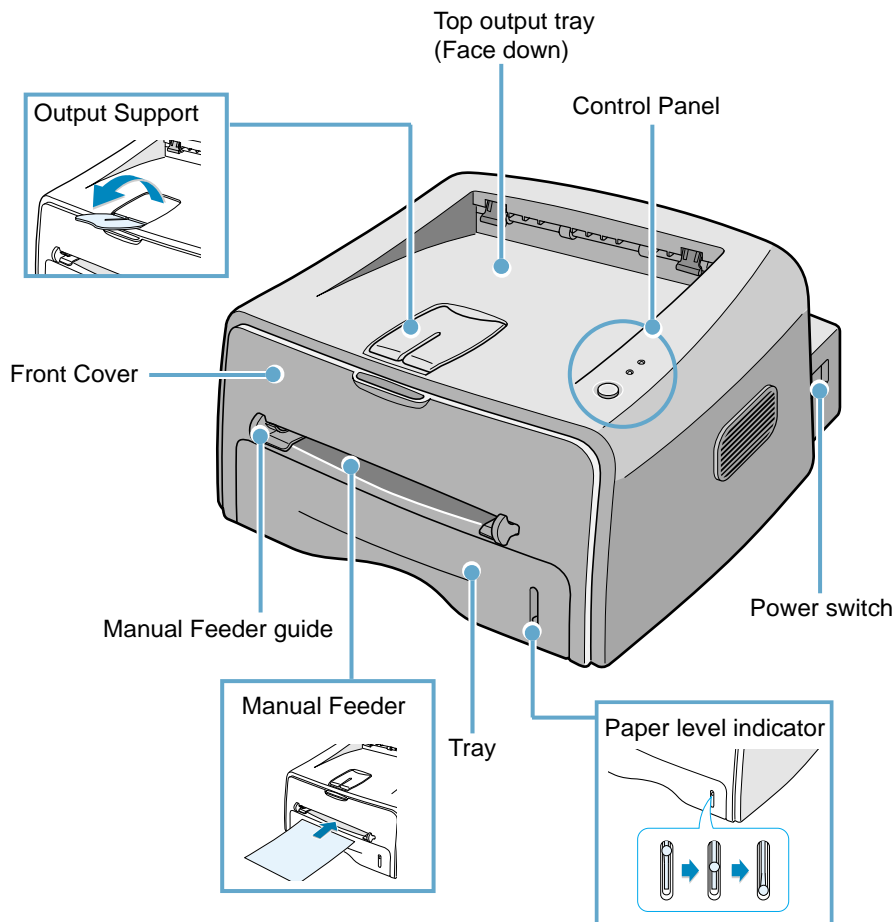

4.1.2 Rear View

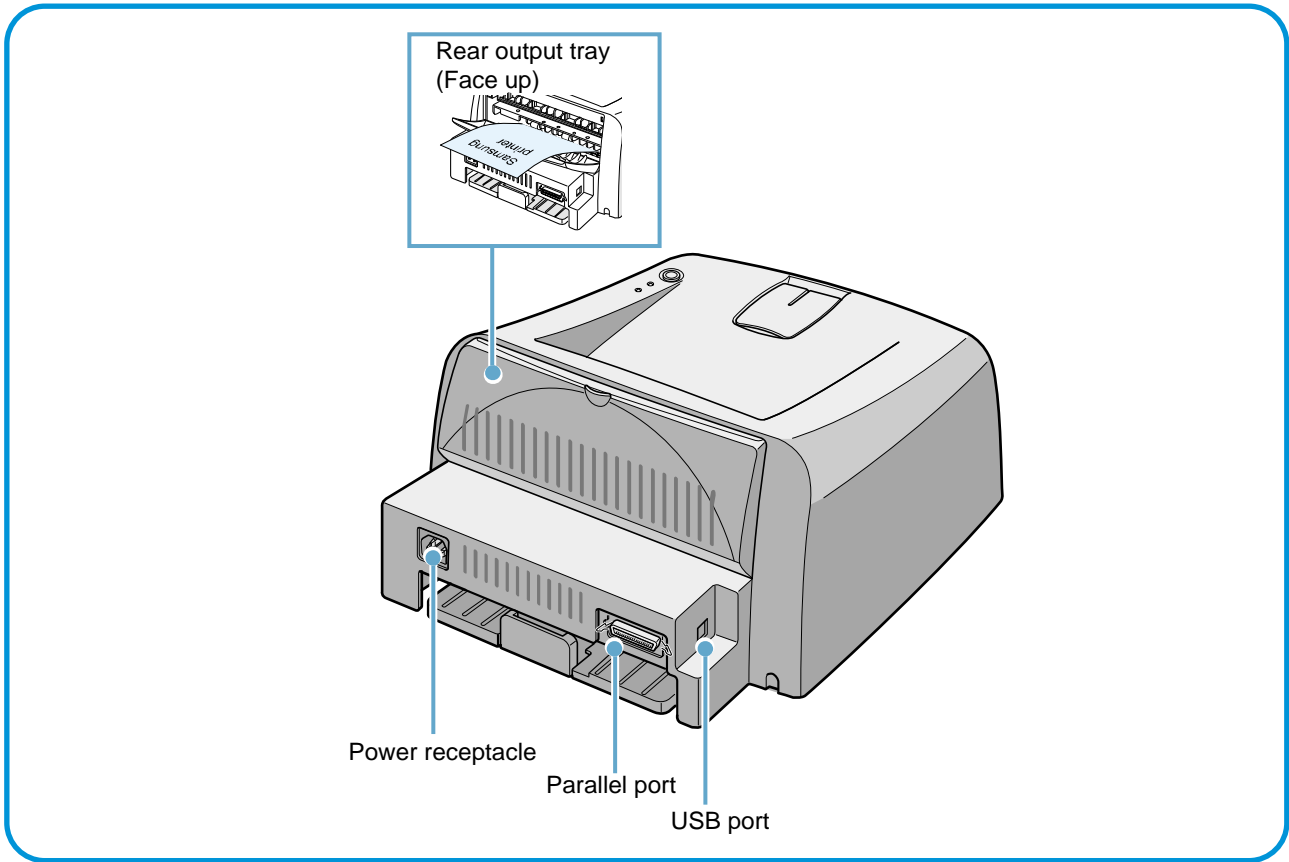

4.1.3 Inside View

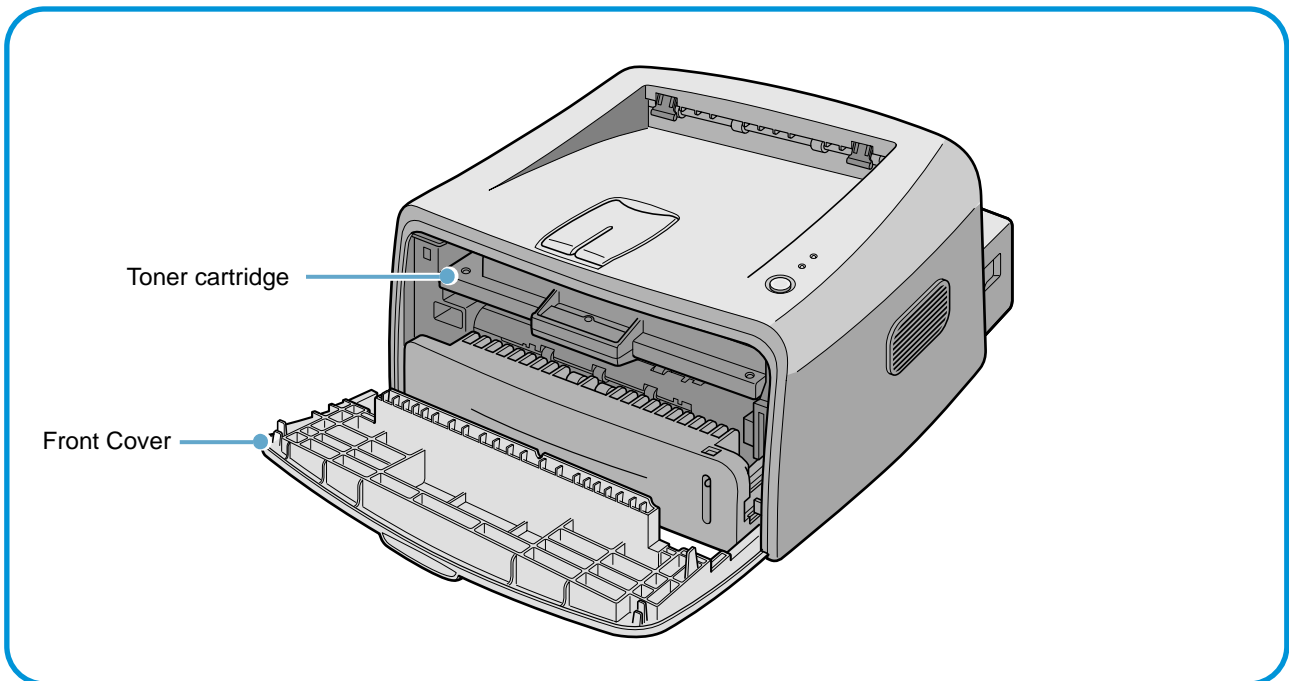

4.1.4 Control Panel

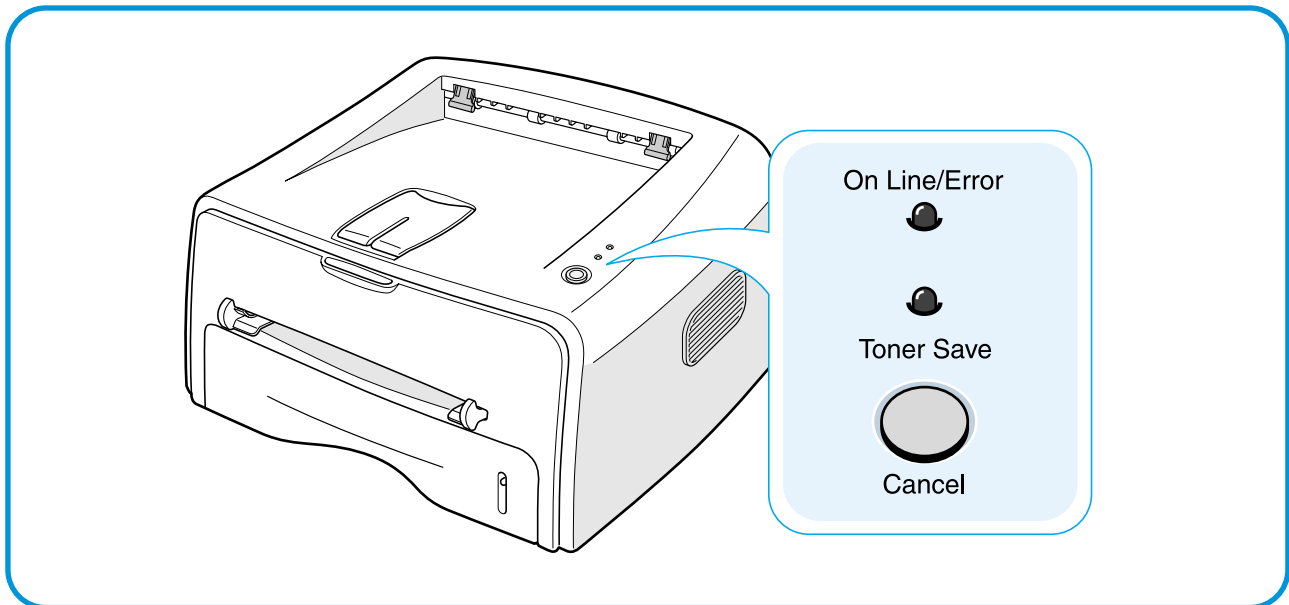

1) On Line/Error and Toner Save LEDs

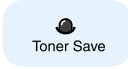
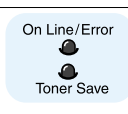
LED	Description
	<p>If the On Line/Error lights green, the printer is ready to print.</p> <p>If the On Line/Error lights red, the printer is experiencing an error, such as jammed paper, the open cover or the empty toner cartridge. If you press the Cancel button while the printer is receiving data, the On Line/Error LED blinks red to cancel printing.</p> <p>In Manual Feed mode, if there is no paper in the Manual Feeder, the On Line/Error LED blinks red. Load paper into the Manual Feeder and the LED stops blinking.</p> <p>If the printer is receiving data, the On Line/Error LED slowly blinks green.</p> <p>If the printer is printing the received data, the On Line/Error LED blinks green fast.</p>
	<p>If you press the Cancel button in Ready mode, this LED is on and the Toner Save mode is enabled.</p> <p>If you press this button once again, this LED is off and the Toner Save mode is disabled.</p>
	<p>If the On Line/Error and Toner Save LEDs blink, your system has some problems. To solve the problem.</p>

2) Cancel button

Printing demo page

In Ready mode, press and hold this button for about 2 seconds until all LEDs blink slowly, and release.

Printing configuration sheet

In Ready mode, press and hold this button for about 6 seconds until all LEDs blink fast, and release.

Manual feeding

Press this button each time you load a sheet of paper in the manual feeder, when you select Manual Feed for Source from your software application.

Cleaning inside printer

In Ready mode, press and hold this button for about 10 seconds until all LEDs turn on, and release. After cleaning the printer, one cleaning sheet prints.

Canceling print job

Press this button during printing. The On Line/Error LED blinks while the print job is cleared from both the printer and the computer, and then return to Ready mode. This may take some time depending on the size of the print job.

In Manual Feed mode, you can't cancel the print job by pressing this button.

Toner Save mode on/off

In Ready mode, press this button to turn the Toner Save mode on or off.

4.2 System Layout

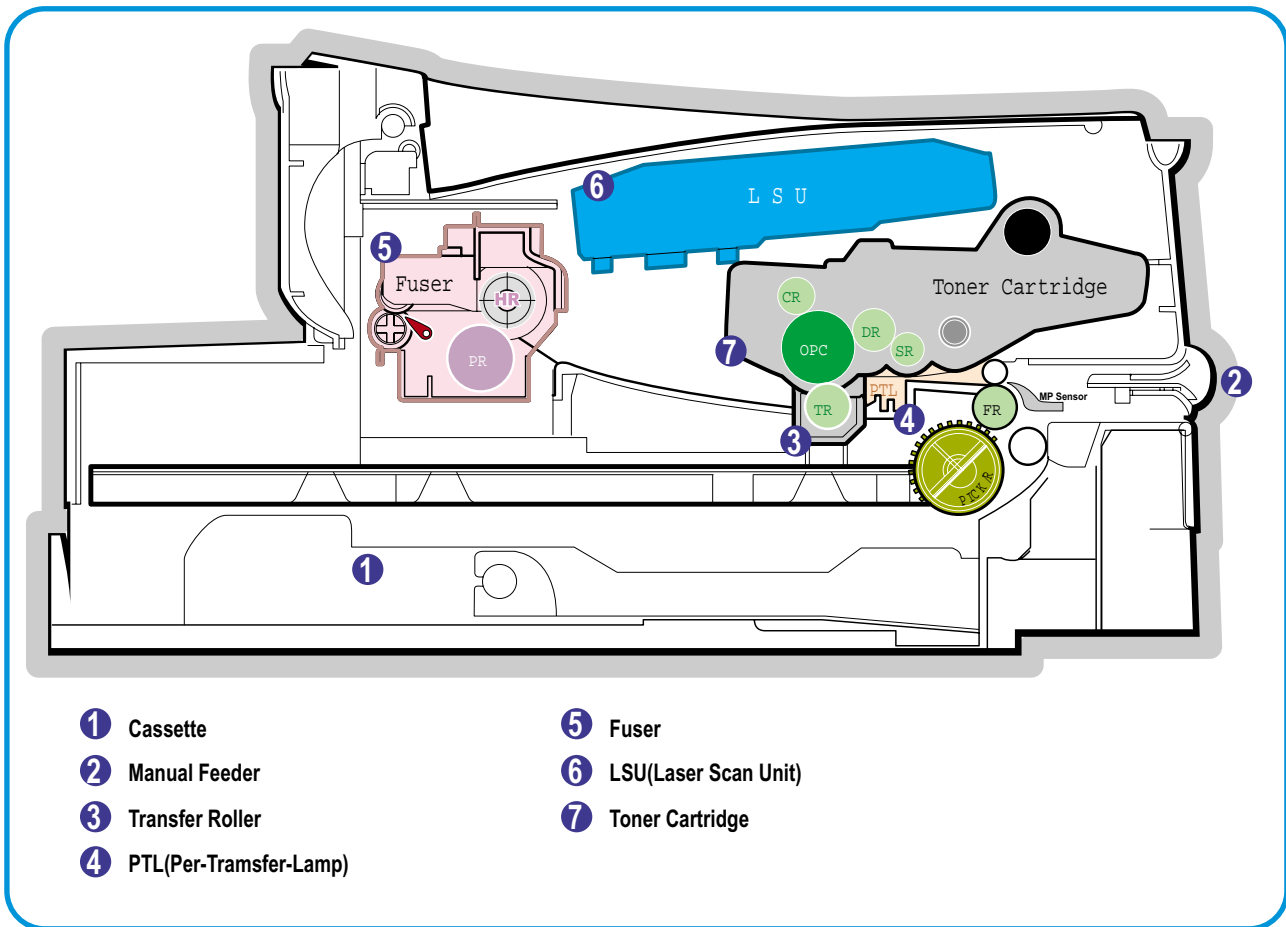

4.2.1 Feeding Part

There are the universal cassette, which loads papers, and the manual feeder, which supplies paper one by one. The cassette has the function pad which separates paper one by one, and it has the sensor function to check the existence of the loading paper.

- Feeding Method: Universal Cassette Type
- Feeding Standard: Center Loading
- Feeding Capacity: Cassette-250 sheets (75g/m², 20lb paper standard)
Manual 1 sheet (Paper, OHP, Envelop, etc.)
- Paper detecting sensor: Photo sensor
- Paper size sensor: None

4.2.2 Transfer Ass'y

It is consisted of the PTL (pre-transfer lamp) and the Transfer Roller. The PTL sends a light to the OPC drum, makes the current on the drum surface to low, and improves the transfer efficiency. The transfer roller delivers the toner of the OPC drum to the paper.

- The life span: Print over 60,000 sheets (in 15~30°C)

4.2.3 Driver Ass'y

It is a power delivery unit by gearing. By driving the motor, it supplies the power to the feeding unit, the fusing unit, and the distributing unit.

4.2.4 Fixing Part(Fuser)

- The fuser is consisted of the Heat Lamp, Heat Roller, Pressure Roller, Thermistor, and Thermostat. It adheres the toner to the paper with a pressure and a heat to complete the printing job.
- There are two methods, the existing method which use the Heat Lamp and the Q-PID which is developed by Samsung.
 - 110V : Heat Lamp type Fuser
 - 120V : Q-PID type Fuser

4.2.4.1 Temperature-Intercepting Device (Thermostat)

The thermostat is the temperature-intercepting device, which cuts off the power for preventing an overheating or a fire when the heat lamp or the heat coil of the heat roller is overheated.

4.2.4.2 Temperature Detecting Sensor (Thermistor)

The Thermistor detects the surface temperature of the heat roller, and it maintains the regular temperature of the heat roller by responding to the information of the temperature.

4.2.4.3 Heat Roller

The heat roller transfers the temperature from the heat lamp or heat coil to the surface to heat the paper which passes the surface. The melted toner cannot stain the heat roller coated with Teflon.

The heating elements are heat lamp and heat coil. For this product, Q-PID method with the heat coil is applied.

4.2.4.4 Pressure roller

The pressure roller mounted right under the heat roller is made of the silicon resin, and the surface of the roller is coated with Teflon to fuse the toner on the paper when paper passes between the heat roller and the pressure roller.

4.2.4.5 Safety Relevant Facts

- Protecting device when overheating
 - 1st protecting device: H/W cuts off when detecting an overheating
 - 2nd protecting device: S/W cuts off when detecting an overheating
 - 3rd protecting device: Thermostat cuts off the power
- Safety device
 - The power of the fuser is cut off when the front cover is open.
 - The overheating safety device for customer
 - Maintains the surface temperature of the Fuser Cover under 80°C and attach the caution label inside of the rear cover where customer can find easily.

4.2.5 LSU (Laser Scanner Unit)

The LSU unit is controlled by the video controller. It scans the video data received from video controller with laser beam by using the rotation principal of the polygon mirror to create the latent image on the OPC drum. It is the core part of LBP.

The OPC drum rotates as the same speed as the paper feeding speed. It creates the /HS YNC signal and sends it to the engine when the laser beam of the LSU reaches the end of the polygon mirror, and the engine detects the /HS YNC signal to arrange the vertical line of the image on the paper. After detecting the /HS YNC signal, the image data is sent to the LSU to arrange the its left margin on the paper. The one side of the polygon mirror is one line for scanning.

4.2.6 Toner Cartridge

By using the electronic photo process, it creates a visual image. In the toner cartridge, the OPC unit and the developer unit are in a body. The OPC unit has OPC drum and charging roller, and the developer unit has toner, toner cartridge, supply roller, developing roller, and blade (Doctor blade)

- Developing Method: Non magnetic 1 element contacting method
- Toner: Non magnetic 1 element shatter type toner
- The life span of toner: 3,000 sheets (IDC Pattern/A4 standard)
- Toner remaining amount detecting sensor: None
- OPC Cleaning: Collect the toner by using electric static + FILM OPC
- Management of disusable toner: Collect the toner by using electric static (Clenerless Type- No disusable toner)
- OPC Drum protecting Shutter: None
- Classifying device for toner cartridge: ID is classified by interruption of the frame channel.

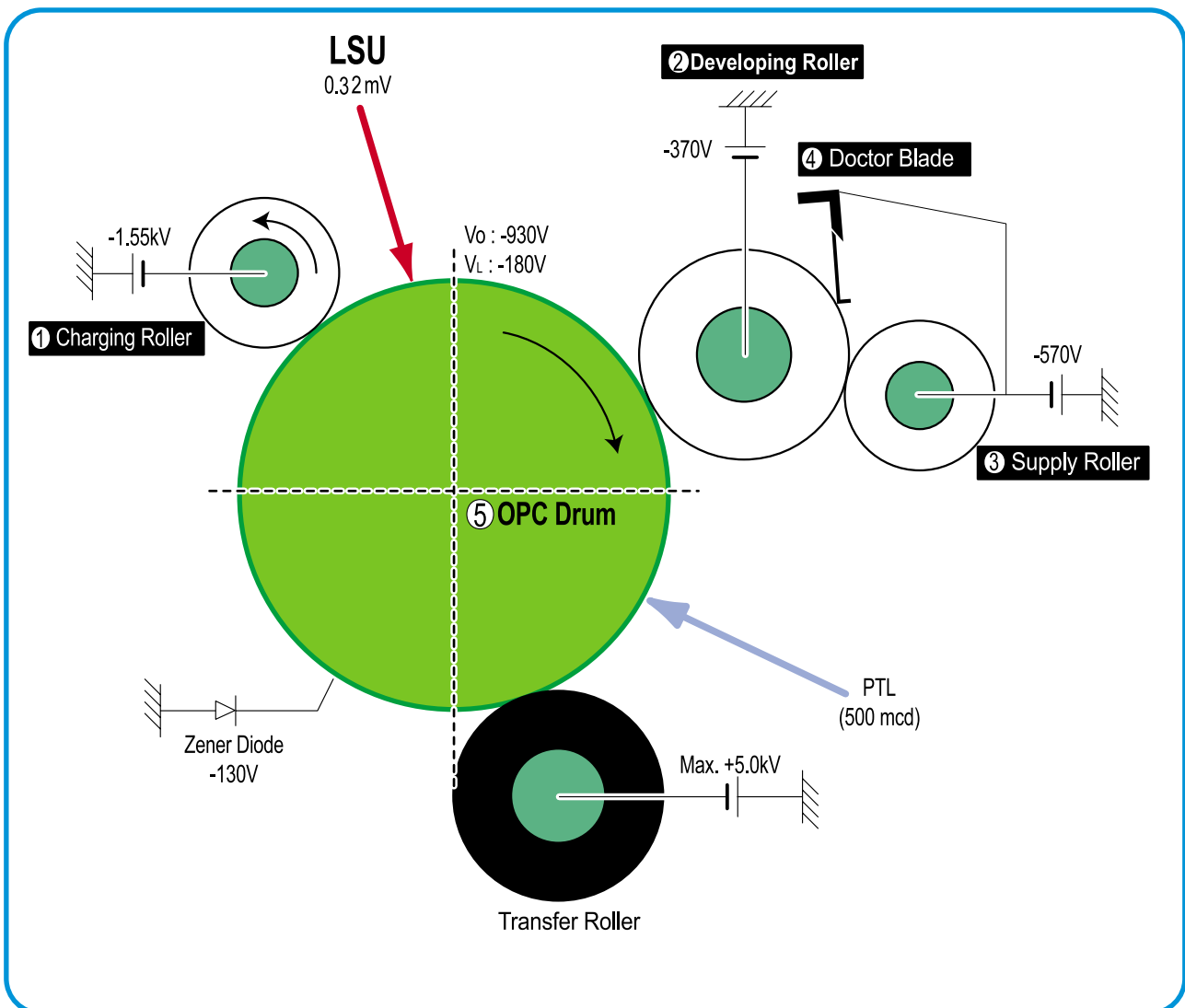

4.3 Main PBA(SPL Model)

The Engine Board and the Controller Board are in one united board, and it is consisted of CPU part and print part in functional aspect. The CPU is functioned as the bus control, I/O handling, drivers, and PC interface. The main board sends the Current Image dlml Video data to the LSU and manages the conduct of Electrophotography for printing. It is consisted of the circuits of the motor (paper feed, pass) driving, clutch driving, pre-transfer lamp driving, current driving, and fan driving. The signals from the paper feed jam sensor and paper empty sensor are directly inputted to the main board.

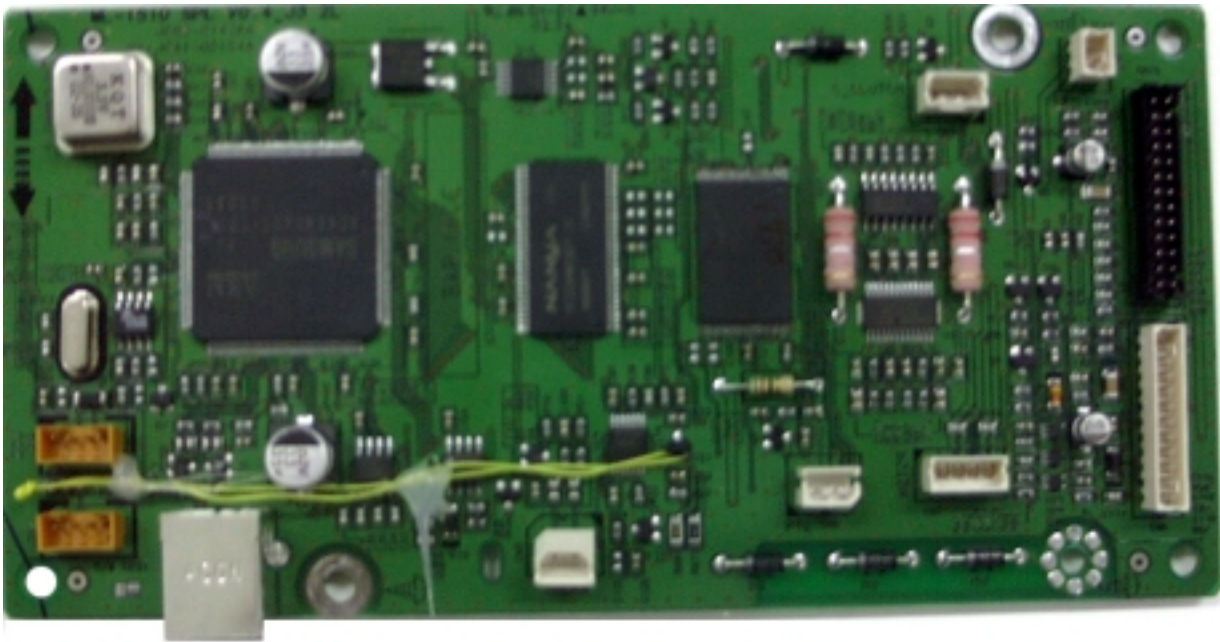

4.3.1 ASIC (Jupiter IV)

The Jupiter IV (16Bit RISC Processor), which is the executive controller to operate the printer function, is in use, and the each operation block is driven by system program of the flash memory. The whole system is controlled by driving operation block.

•Main function block

- Completely Integrated System for Embedded Applications,
- 16 Bit Risc Architecture, Efficient and Powerful ARM7TDMI CPU
- LSU Interface Module for Interfacing PVC or HPVC with LSU
- 2 Channel General Purpose DMA Controller for High Speed I/O
- Dual Memory Bus Architecture
- Operating frequency : 80MHz
- Operating power : 3.3V
- Power on reset time : under 6.6ms

4.3.2 Flash Memory

It stores the system program and downloads the system program through the PC interface.

- Capacity : 0.5M Byte
- Access Time : 70 nsec

4.3.3 SDRAM

It is used as a swath buffer, system working memory area, etc. while printing.

- Capacity : The 2M byte is for the ML-1710 (2M : Printing system working memory area)
The 16Mbyte is for the ML-1750 (8M, ML-1750G/1760G)
- Access Time : 60 nsec

4.3.4 Sensor input circuit

1) Paper Empty Sensing

The Paper empty sensor (Photo Interrupter) on the engine board informs the state of paper to CPU whether it is empty or not with operation of the actuator.

When cassette is empty, it detects the fact by reading the D0 Bit of CPU, and then informs the fact by selecting the second LED(yellow) among the panel LEDs.

2) MP Sensing

By operation of Actuator on the frame, the MP Sensor (Photo Interrupter) on the engine board informs the state of paper to CPU whether it is empty or not. It reads the D0 Bit of CPU for recognizing paper in MP, and paper is fed from MP if there is.

3) Paper Feeding/Width , Toner Cartridge Sensing

When paper passes the actuator (feed sensor part), it detects the signal of Photo interrupter, informs the paper feeding state to CPU, and then sprays the image data after certain time.

If it doesn't detect the feed sensor within 1 sec. after paper is fed, paper Jam0 (CPU #_) is occurred (Red and Yellow will be turned on among the OP panel LEDs), and the fact whether the developer is inserted or not is detected with the same principle. After the developer is mounted, the actuator is operated. The signal from the photo interrupter is detected when it is passing the actuator of the sensor part. That is the developer ID sensing.

4) Paper Exit Sensing

It detects paper state whether paper gets out from the set with operation of exit sensor on the engine board and actuator on the frame. Paper detects the on/off time of exit sensor by reading D2 Bit of CPU, and the normal operation or jam information is informed to the CPU.

The paper JAM2 is informed. (Red, Yellow LED will be turned on among the OP panel LEDs)

5) Cover Open Sensing

The Cover open sensor is located on the front cover. After the front cover is opened, +24V (DC fan, solenoid, main motor, polygon motor part of LSU, HVPS,) which is supplied to the each unit, is cut off.

The cover-open sensing is operated by the D0 bit of CPU, and the developer ID sensing is operated by D7 bit of CPU.

In this case, the red LED among OP panel LEDs will be ON for informing the facts to user.

6) DC FAN / SOLENOID Driving

It is driven by transistor and controlled by D6 bit of CPU.

When it is high, the fan is driving by turning on the TR, and it is off when the sleep mode is selected.

There are two solenoids, and they are driven by paper pick-up and MP signal. It is turned on or off by D4 Bit of CPU, and its driving time is 300ms. The diode protects the driving TR from the noise pulse, which is flown when the solenoid is de-energizing.

7) Motor Driving

The motor driving circuit is formed when the Driver IC is selected in the first place. The AN8495 (Motor driver IC) is used in this case. But, the resistance R_s value of sensing and the voltage value of the V reference can be changed by motor driving voltage value. The motor driving voltage is calculated with the following formula.

4.4 Main PBA (PCL Model)

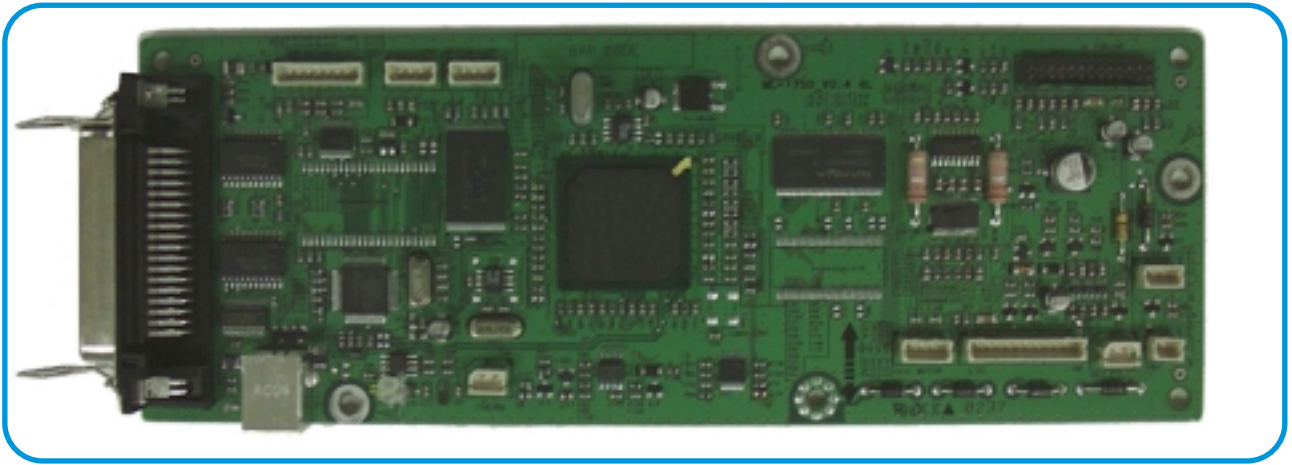

4.4.1 Asic(SPGPm)

1) ARM946ES

- 32-bit RISC embedded processor core
- 16KB instruction cache and 16KB data cache
- No Tightly Coupled Memory
- Memory Protection Unit & CP15 control program

2) Dual bus architecture for bus traffic distribution

- AMBA High performance Bus (AHB)
- System Bus with SDRAM

3) IEEE1284 compliant parallel port interface

4) Printer Video Controller for LBP engines

5) Graphic Execution Unit for Banding support of Printer Languages

6) Printer Video Controller for LBP engines

- PVC : Printer Video Controller without RET Algorithm
- HPVC : Printer Video Controller with RET algorithm (Line Memory & Lookup Table Memory : 512 x 8 , 4096 x 16)

7) Engine Controller

- Motor Control Unit
- Motor Speed Lookup Table Memory (128 x 16 x 2)
- Pulse Width Modulation Unit
- 4 Channels are supported
- ADC Interface Unit
- 3 ADC Channels are available
- ADC Core (ADC8MUX8) maximum clock frequency : 3 MHz

8) USB 2.0 Interface

9) Package

- 272 pins PBGA

10) Power

- 1.8V(Core), 3.3V(IO) power operation

11) Speed

- 166MHz core(ARM946ES) operation, 60MHz bus operation

4.4.2 Memory

1) Flash Memory

- It stores the System Program, downloads the System program through PC Interface, and compresses the PCL font, then stores it.
- Capacity : 2M Byte
- Access Time : 70 nsec

2) DRAM

- It is used as Swath buffer, System working memory area, etc. when printing. It stores the font list, compressed into flash memory, on DRAM and uses it as PCL font.
- Capacity : 8M Byte (Basic), upto 64M Byte (Factory Option)
- Type : SDRAM 100MHz/133MHz , 16bit

4.4.3 Other

The option PBA can be mounted for supporting the serial communication.

4.4.4 SPGPM Internal Block Diagram

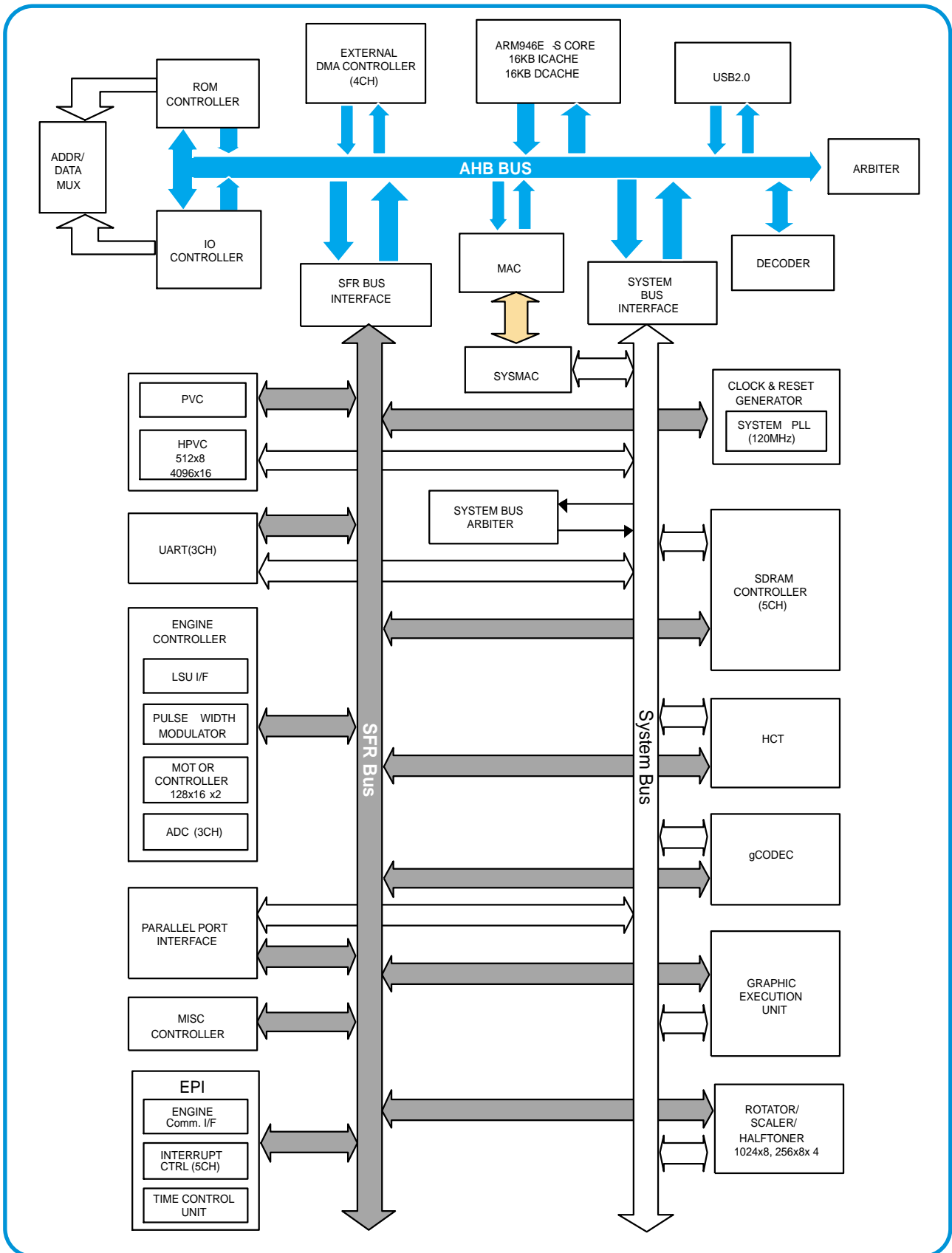

4.5 SMPS & HVPS

The SMPS supplies the DC power to the system.

It takes 110V/220V and outputs the +3.3V and +24V to supply the power to the main board and ADF board. The HVPS part creates the high voltage of THV/MHV/Supply/Dev and supplies it to the developer part for making the best condition to display the image. The HVPS part takes the 24V and outputs the high voltage for THV/MHV/BIAS, and the outputted high voltage is supplied to the toner, OPC cartridge, and transfer roller.

4.5.1 HVPS(High Voltage Power Supply)

1) Transfer High Voltage (THV+)

- Inputting voltage : 24 V DC \pm 15%
- Outputting voltage : +5.0KV \pm 5 %, (Duty 10% , %, no loading)
- 1.0KV \pm 15% (When cleaning, 200 M Ω)
- Outputting voltage Trigger : 6.5 μ A
- Inputting contrast of the Voltage stability degree : under \pm 5% (fluctuating input 21.6V~26.4V)
Loading contrast : under \pm 5%
- Outputting voltage Rising Time : 100 ms Max
- Outputting voltage Falling Time : 100 ms Max
- Fluctuating transfer voltage with environmental various : +650 V (Duty 10%) ~ 5 KV (Duty 90%)
- Environmental recognition Controlling method : The THV-PWM Active is transfer active signal. It detects the resistance by recognizing the voltage value, F/B, while permits the environmental recognition voltage.
- Outputting voltage Controlling method : The transfer output voltage is outputted and controlled by changing the duty of THVPWM signal.
10% Duty : +650V, 90% Duty : +5KV \pm 5%

2) Charge Voltage (MHV)

- Inputting voltage : 24 V DC \pm 15%
- Outputting voltage : -1.3KV ~ -1.8KV DC \pm 50V
- Outputting voltage Rising Time : 50 ms Max
- Outputting voltage Falling Time : 50 ms Max
- Output loading range : 30 M Ω ~ 1000 M Ω
- Output controlling signal (MHV-PWM) : CPU output is high when the PWM is low

3) Cleaning Voltage (THV-)

- The (+) transfer voltage is not outputted because the THVPWM is controlled with high.
- The (-) transfer voltage is outputted because the THV-Enable signal is controlled with low.
- The outputting fluctuation range is big because there is no feedback control.

4) Developing Voltage (DEV)

- Inputting voltage : 24 V DC \pm 15%
- Outputting voltage : -200V ~ -600V DC \pm 20 V
- Outputting voltage fluctuating range : PWM control
- Inputting contrast of the output stability degree : under \pm 5% Loading contrast : under \pm 5%
- Output voltage rising time : 50ms Max
- Output voltage falling time : 50ms Max
- Output loading range : 10M Ω ~ 1000M Ω
- Output controlling signal (BIAS-PWM) : the CPU output is high when PWM is low.

5) Supply Voltage

- Outputting voltage : -400 V ~ -800V DC \pm 50 V(Using ZENER, DEV)
- Inputting contrast of the output stability degree : under \pm 5%
Loading contrast : under \pm 5%
- Output voltage rising time : 50 ms Max
- Output voltage falling time : 50 ms Max
- Output loading range : 10 M Ω ~ 1000 M Ω
- Output controlling signal (BIAS-PWM) : the CPU output is high when PWM is low.

4.5.2 SMPS(Switching Mode Power Supply)

It is the power source for the whole system. It is an independent module, so it is possible to use for common use. It is mounted at the bottom of the set.

It is consisted of the SMPS part, which supplies the DC power for driving the system, and the AC heater control part, which supplies the power to fuser. SMPS has two outputting channels (3.3V and +24V).

There are three kinds of power, 120V exclusive (America), 220V exclusive (Europe), and 220V for china (nations with instable power supply).

1) AC Input

- Inputting rated voltage : AC 220V ~ 240V AC 120V / AC 220V
- Inputting voltage fluctuating range : AC 198V ~ 264V AC 90V ~ 135V / AC 198V ~ 264V
- Rated frequency : 50/60 Hz
- Frequency fluctuating range : 47 ~ 63 Hz
- Inputting voltage : Under 4.0Arms/2.0Arms (The state when lamp is off or rated voltage is inputted/outputted)

2)Rated Power Output

NO	Item	CH1	CH2	Remark
1	Channel name	+3.3V	+24.0V	
2	CONNECTOR PIN	CON 3 5V PIN: 1,3,5 GND PIN: 2,4,6	CON 3 24V PIN: 9,11,13 GND PIN: 10,12,14	
3	Rated outputting voltage	3.3V \pm 5% (3.2 \neq 3.4V)	+24V \pm 10% (21.6 \neq 26.4V)	
4	Maximum outputting voltage	1.0 A	2.0 A	
5	Peak loading voltage	1.5 A	2.5 A	1ms
6	Ripple noise voltage	100mVp-p	500mVp-p	
7	Maximum output	3.3W	48W	
8	Peak output	4.95W	60W	1ms
9	Protection for loading short and overflowing voltage Consumption Power	-	-	-

3)Consumption Power

NO	Item	CH1 (+3.3V)	CH3 (24V)	System
1	Stand-By	1.0 A	0.4 A	AVG : 55 Wh
2	PRINTING	1.0 A	2.0 A	AVG : 250 Wh
3	Sleep-Mode	0.8A	0.4A	AVG : 10 Wh

4) Length of Power Cord

- 1830 ± 50mm

5) Power Switch

- Use

6) Feature

- Insulating resistance : over 50MΩ (at DC500V)
- Insulating revisiting pressure : Must be no problem within 1min. (at 1500Vzc, 10mA)
- Leaking voltage : under 3.5mA
- Running voltage : under 40A peak (at 25°C, Cold start) Under 60A peak (in other conditions)
- Rising Time : Within 2Sec
- Falling Time : Over 20ms
- Surge : Ring Wave 6KV-500A (Normal, Common)

7) Environment Condition

- Operating temperature range : 0°C ~ 40°C
- Maintaining temperature range : -25°C ~ 85°C
- Maintaining humid range : 30% ~ 90% RH
- Operating atmospheric pressure range : 1

8) EMI Requirement

- CISPR ,FCC, CE, MIC, C-Tick,

9) Safty Requirement

- IEC950 UL1950, CSA950, C-UL,NOM,TUV,Semko,Nemko,iK,CB, CCC(CCIB),GOST, EPA,

4.5.3 Fuser AC Power Control

Fuser (HEAT LAMP) gets heat from AC power. The AC power controls the switch with the Triac, a semiconductor switch. The 'On/Off control' is operated when the gate of the Triac is turned on/off by Photo triac (insulating part).

In the other words, the AC control part is passive circuit, so it turns the heater on/off with taking signal from engine control part.

When the 'HEATER ON' signal is turned on at engine, the LED of PC1 (Photo Triac) takes the voltage and flashes. From the flashing light, the Triac part (light receiving part) takes the voltage, and the voltage is supplied to the gate of Triac and flows into the Triac. As a result, the AC current flows in the heat lamp, and heat is occurred.

On the other hand, when the signal is off, the PC1 is off, the voltage is cut off at the gate of Triac, the Triac becomes off, and then the heat lamp is turned off.

1) Triac (THY1) feature

- 12A,600V SWITCHING

2) Phototriac Coupler (PC3)

- Turn On If Current : 15mA ~ 50mA(Design: 16mA)
- High Repetive Peak Off State Voltage : Min 600V

4.6 Engine F/W

4.6.1 Feeding

If feeding from a cassette, the drive of the pickup roller is controlled by controlling the solenoid. The on/off of the solenoid is controlled by controlling the general output port or the external output port. If feeding from a manual feeder, decide to insert the paper according to the operation of the manual sensor, and by driving the main motor, insert the paper in front of the feed sensor. While paper moves, occurrence of jam is judged as below. (Refer to the [6.2 Paper Transfer rout])

4.6.1.1 Jam 0

- After picking up, paper cannot entered due to paper didn't feed.
- After picking up, paper entered but it cannot reach to the feed sensor in certain time due to slip, etc.
- After picking up, if the feed sensor is not on, repack up. After repacking up, if the feed sensor is not on after certain time, it is Jam 0.
 - It is a status that the leading edge of the paper doesn't pass the feed sensor.
- Even though the paper reaches to the feed sensor, the feed sensor doesn't be on.
 - It is a status that the leading edge of the paper already passes the feed sensor.

4.6.1.2 Jam 1

- After the leading edge of the paper passes the feed sensor, the trailing edge of the paper cannot pass the feed sensor after certain time. (The feed sensor cannot be Off)
- After the leading edge of the paper passes the feed sensor, the paper cannot reach the exit sensor after certain time. (The exit sensor cannot be On)
 - The paper exists between the feed sensor and the exit sensor.

4.6.1.3 Jam 2

- After the tailing edge of the paper passes the feed sensor, the paper cannot pass the exit sensor after certain time.

4.6.2 Drive

By gearing, the main motor drives the rollers such as feeding roller, developing roller, fuser roller, and distributing roller. The step motor is controlled for the sections, acceleration section and fixed speed section. In the initial stage of the motor run, appoint the acceleration section to prevent the isolation of the motor. It is controlled by the A3977 motor driver IC. The step signal and the enable signal are sent to make the phase for driving the motor in CPU.

4.6.3 Transfer

The charging voltage, developing voltage and the transfer voltage are controller by PWM (Pulse Width Modulation). The each output voltage is changeable due to the PWM duty. The transfer voltage admitted when the paper passes the transfer roller is decided by environment recognition. The resistance value of the transfer roller is changed due to the surrounding environment or the environment of the set, and the voltage value, which changes due to the environments, is changed through AD converter. The voltage value for impressing to the transfer roller is decided by the changed value.

4.6.4 Fusing

The temperature change of the heat roller's surface is changed to the resistance value through the thermistor. By converting the voltage value, which impressed to the resistance, to the digital value through the AD converter, the temperature is decided. The AC power is controlled by comparing the target temperature to the value from the thermistor. If the value from the thermistor is out of the controlling range while controlling the fusing, the error stated in the table occurs. (For the domestic model, the Q-PID method has been applied.)

4.6.4.1 Heat Lamp Method

Error	Description	DCU	LED Displat
Open heat error	When warming up, it has been lower than 68°C over 28 seconds	60	All LED are flashing.
Lower heat error	<ul style="list-style-type: none"> • Standby: It has been lower than 80°C over 10 seconds • Printing: <ul style="list-style-type: none"> - 2 consecutive pages: it has been lower than 145°C over 4 seconds. - 3 consecutive page; it has been 25°C lower than the fixed fusing temperature over 4 seconds. 	62	All LED are flashing
Over heat error	It have been higher than 220°C over 3 seconds	68	All LED are flashing

4.6.4.2 Q-PID Method

Error	Description	DCU	LED Displat
Open heat error	When preheating, it has been lower than 68°C over 15 seconds.	60	All LED are flashing
Lower heat error	<ul style="list-style-type: none"> • After finishing the preheating stage, it has not reached 100°C (preheating stop temperature) during 15 seconds since the temperature is over 68°C. • Printing <ol style="list-style-type: none"> 1) When the main motor is on and after 0.92 second, it has not reached the 160°C during 20 seconds. 2) From the 2 consecutive pages, it has been 20°C lower than the fusing temperature over 4 seconds. 	62	All LED are flashing
Over heat error	<ul style="list-style-type: none"> • the error is not displayed immediately when it has been over 220°C over 3 seconds. The temperature after the 3 seconds is checked. If it is over 240°C, it is error. • If the temperature has been higher than 220°C over 25 seconds, it is an error even through the temperature doesn't reach 240°C. 	68	All LED are flashing

4.6.4.3 What is the Q-PID Method?

The Q-PID is developed by Samsung, and it saves the preheating time in half in comparison with the existed method. It saves not only the printing time for initial print but also it saves the printing speed for the reattempting print after for a while.

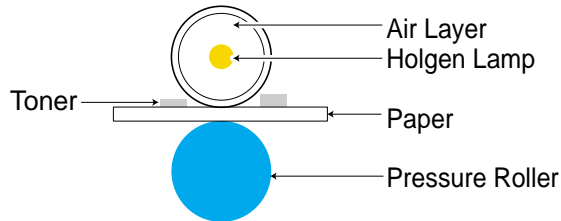

- After heating the air layer, transfer the heat to the surface
- It takes long time to heat it until it reaches the proper temperature.
- The high temperature is needed when it is standby status.

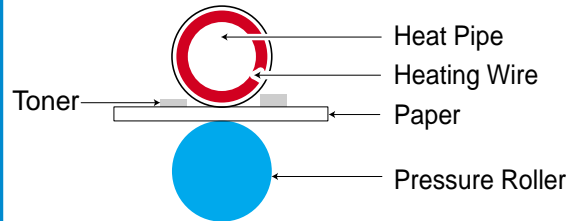

- The heat conductivity of the heat pipe is 100~150 times higher than cooper's.
- It is possible to raise the temperature in an instant
- It saves the dissipation of power in the standby status due to high accumulation of heat.

4.6.5 LSU

The LSU is consisted of the LD (Laser Diode) and the polygon motor control. When the printing signal occurs, it turns the LD and drives the polygon motor. When the receiving light part detects the beam, Hsync occurs. When the polygon motor speed becomes a normal, LReady occurs. If two conditions are satisfied, the status bit of the LSU controller register becomes 1 to be judged that the LSU is ready. If two conditions are not satisfied, the error shown in below occurs.

Error	Description	DCU
Polygon motor error	When the polygon motor's speed doesn't become a normal	95
Hsync error	The polygon motor's speed is normal, but the Hsync signal is not created.	96

5. Disassembly and Reassembly

5.1 General Precautions on Disassembly

When you disassemble and reassemble components, you must use extreme caution. The close proximity of cables to moving parts makes proper routing a must.

If components are removed, any cables disturbed by the procedure must be restored as close as possible to their original positions. Before removing any component from the machine, note the cable routing that will be affected.

Whenever servicing the machine, you must perform as follows:

1. Check to verify that documents are not stored in memory.
2. Be sure to remove the toner cartridge before you disassemble parts.
3. Unplug the power cord.
4. Use a flat and clean surface.
5. Replace only with authorized components.
6. Do not force plastic-material components.
7. Make sure all components are in their proper position.

Releasing Plastic Latches

Many of the parts are held in place with plastic latches. The latches break easily; release them carefully.

To remove such parts, press the hook end of the latch away from the part to which it is latched.

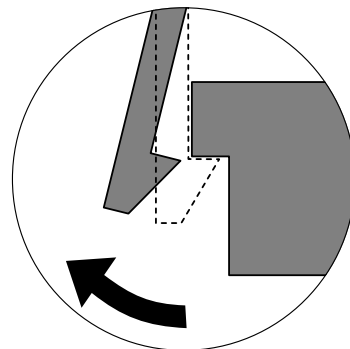

5.2 Top Cover

1. Pull the Cassette out of the printer.

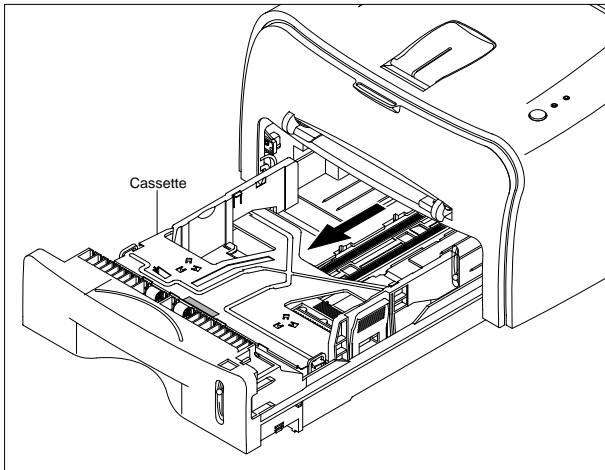

4. Unlatch the front ends of the Top Cover.

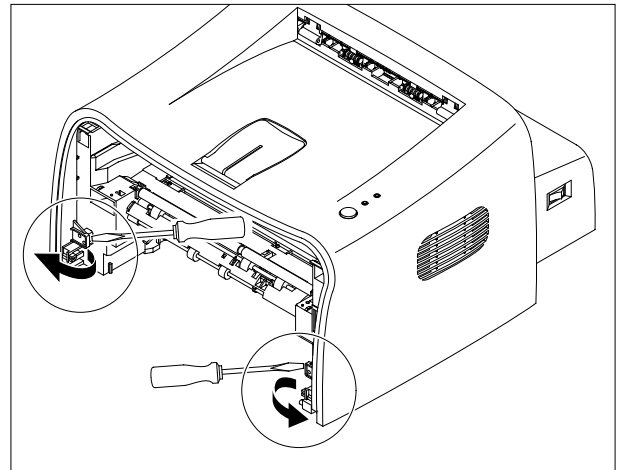

2. Remove the Front Cover in the direction of arrow.

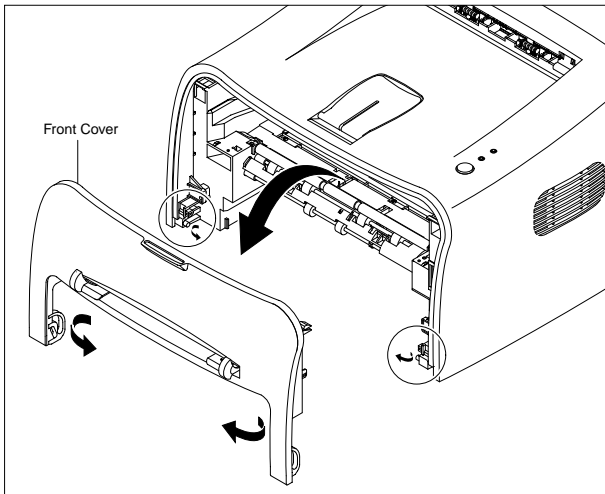

5. Remove the Top Cover in the direction of arrow.

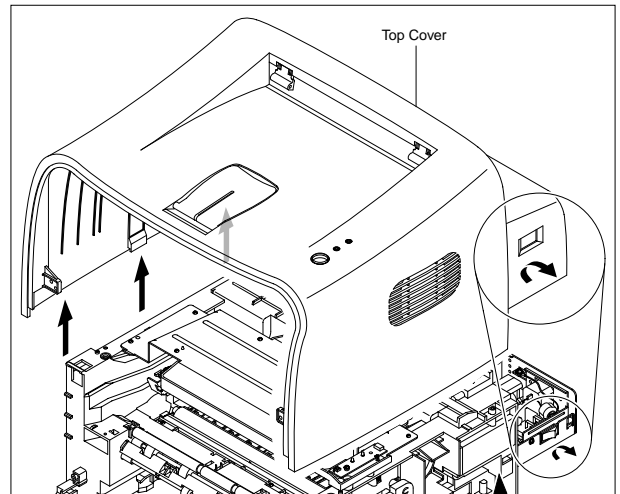

3. Remove four screws.

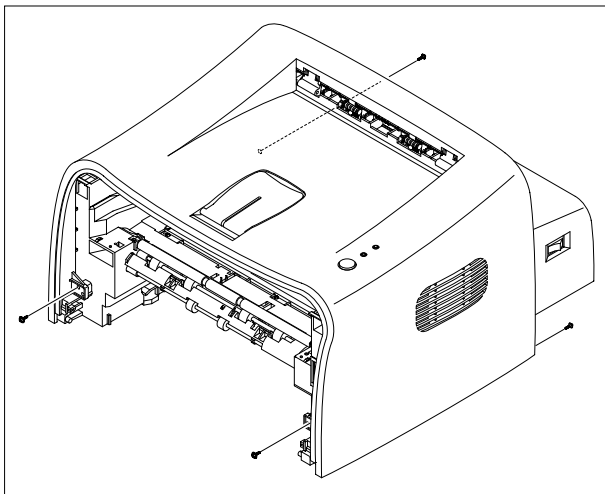

6. Remove the Rear Cover from the Top Cover.

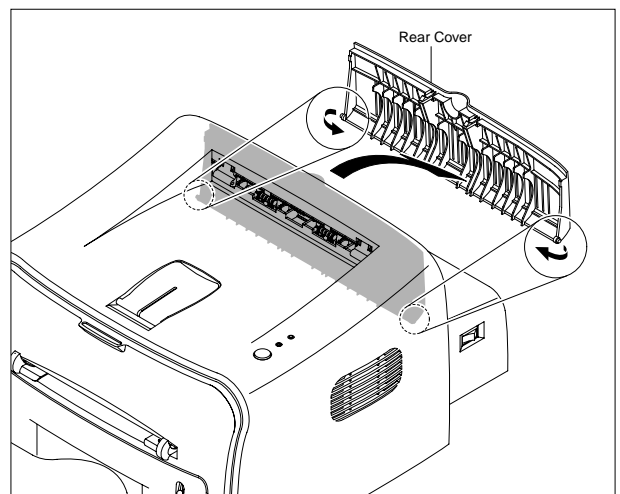

5.3 Fuser

5.3.1 Fuser(110V)

1. Before you remove the Fuser, you should remove:
- Top Cover(see page 5-2)

2. Unplug two connectors(Block) from the boards, then remove four screws.

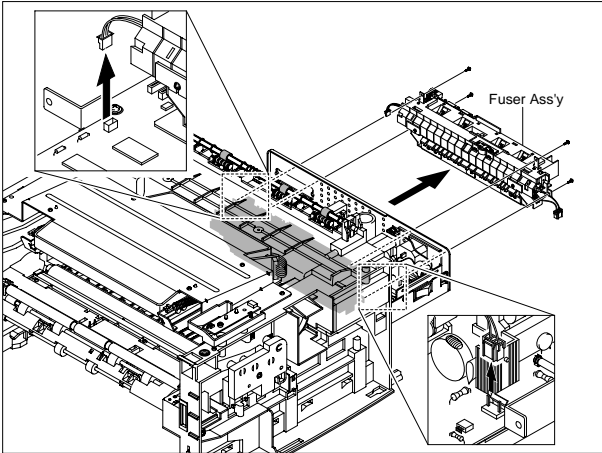

3. Remove two screws and take the Thermostat out of the Fuser.

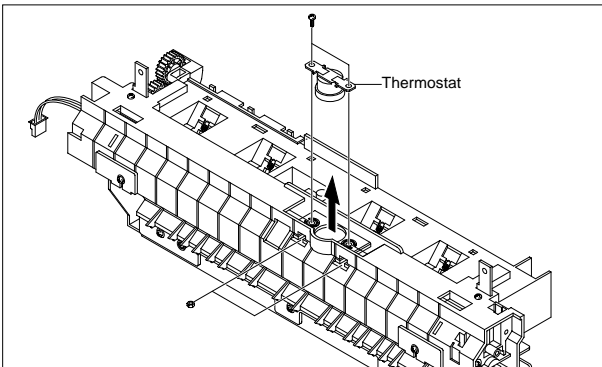

4. Remove two screws and take the Halogen Lamp out of the Heat Roller.

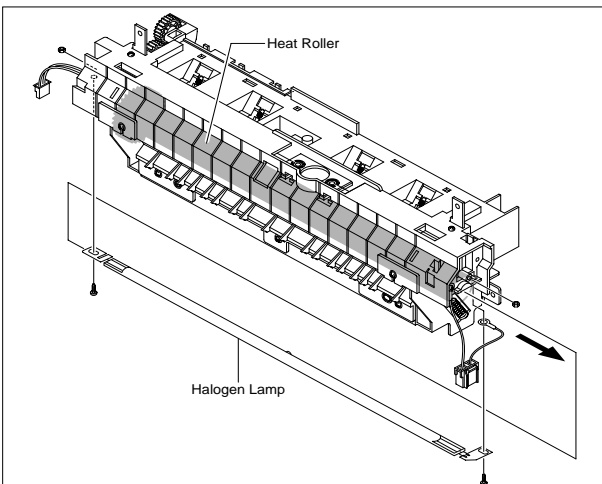

5. Remove one screw and take the Idle Gear out.

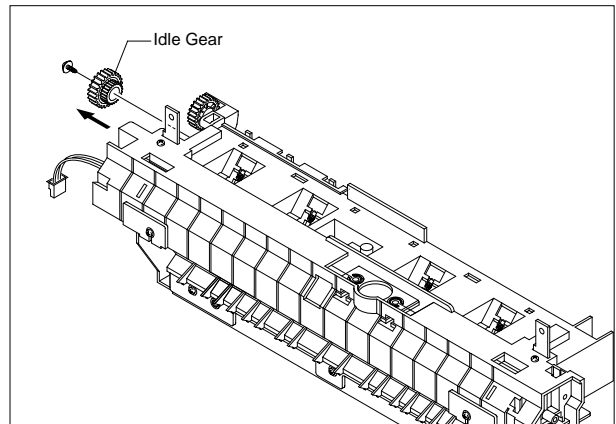

6. Remove four screws and divide the Fuser into two parts

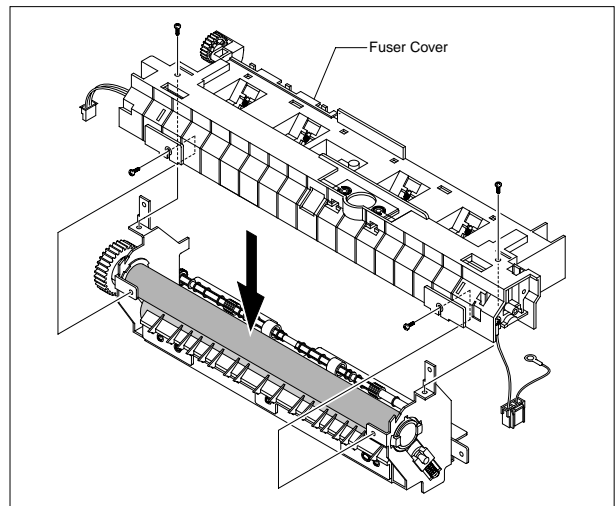

7. Remove the Thermister from the Fuser Cover.

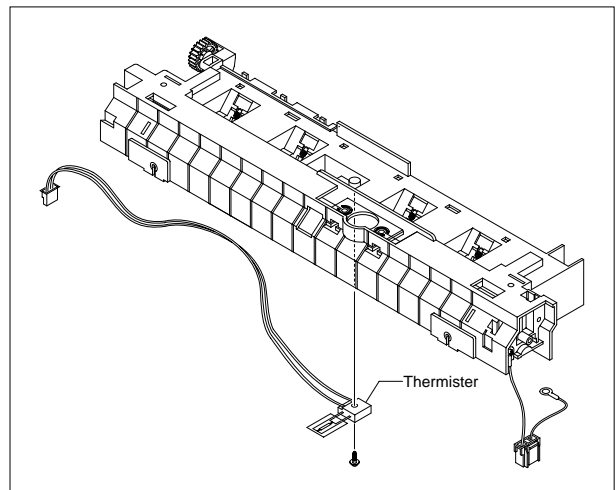

5.3.2 Fuser(220V)

1. Before you remove the Fuser, you should remove:
- Top Cover(see page 5-2)
2. Unplug two connectors(Block) from the boards, then remove four screws.

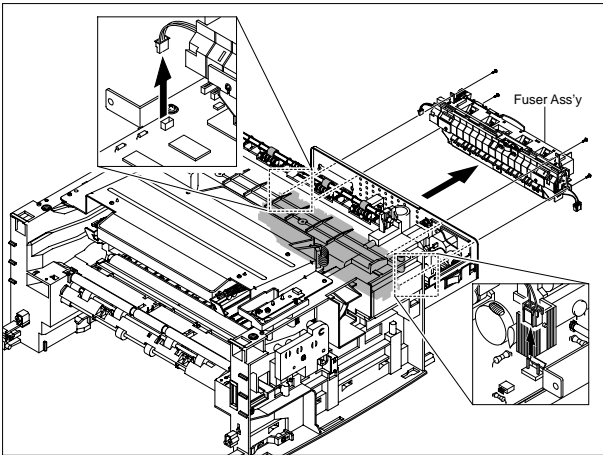

3. Remove two screws and take the Thermostat out of the Fuser.

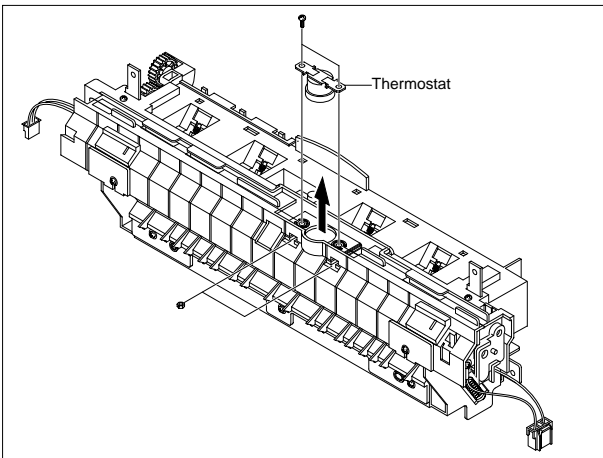

4. Remove two screws.

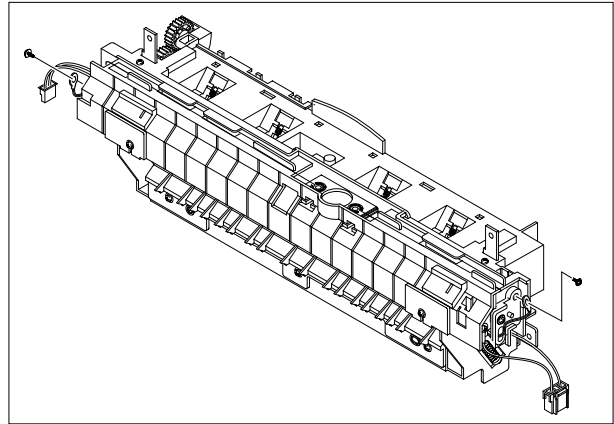

5. Remove one screw and take the Idle Gear out.

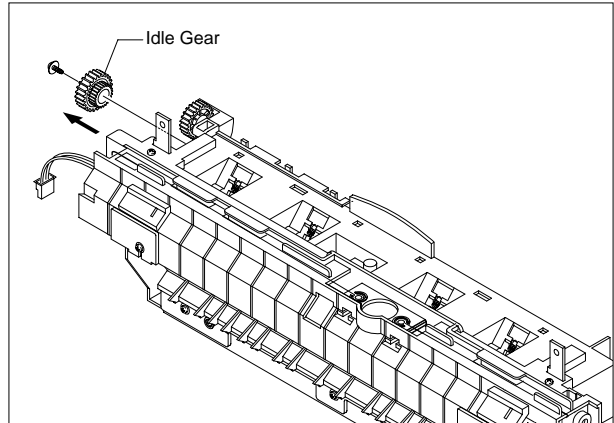

6. Separate Heat Roller Ass'y after remove six screws and
After removing 6 screws as shown in below,
take out the heat roller assembly in direction of
the arrow while pulling the both side of the unit-
brush

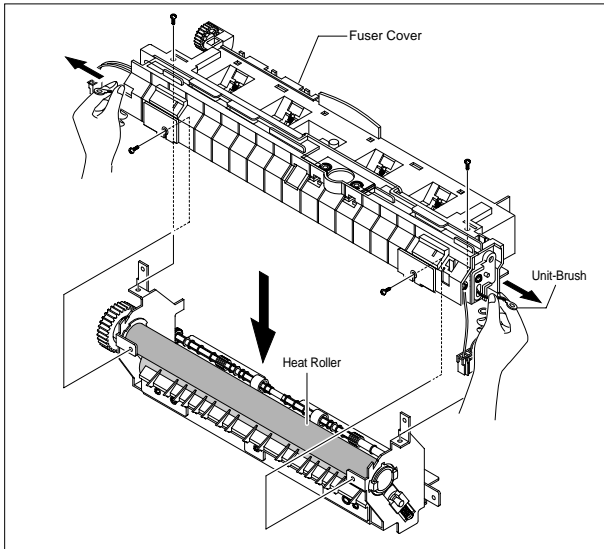

Caution: Be careful not to damage or contaminate the surface of the roller when assembling/disassembling the heat roller.

7. Unplug Thermister Harness from the Fuser cover.

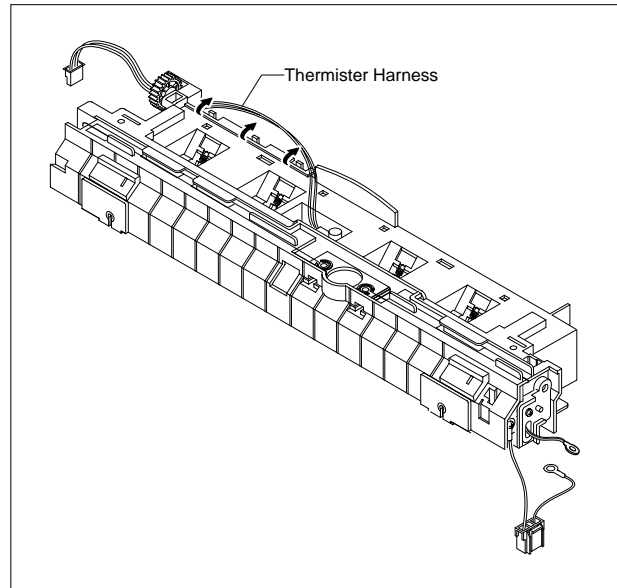

8. Remove one screw and separate Thermister from the inter connector Fuser Cover.

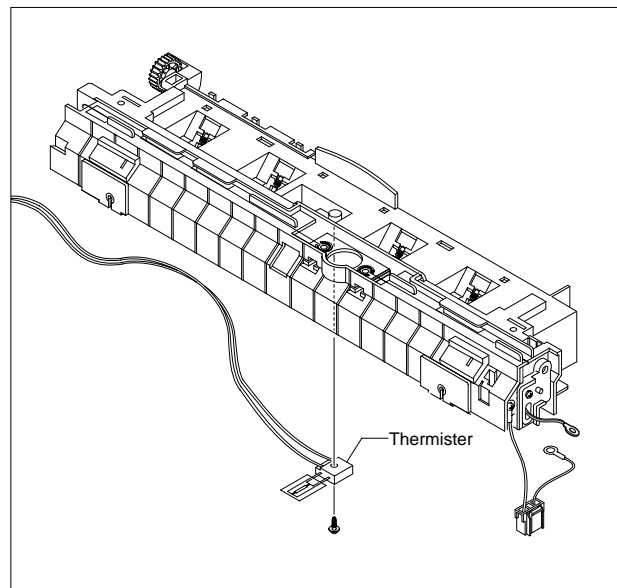

5.4 Exit Roller

1. Before you remove the Fuser, you should remove:
 - Top Cover(see page 5-2)
2. Remove the Exit Gear, Bearing and Exit Roller as shown below

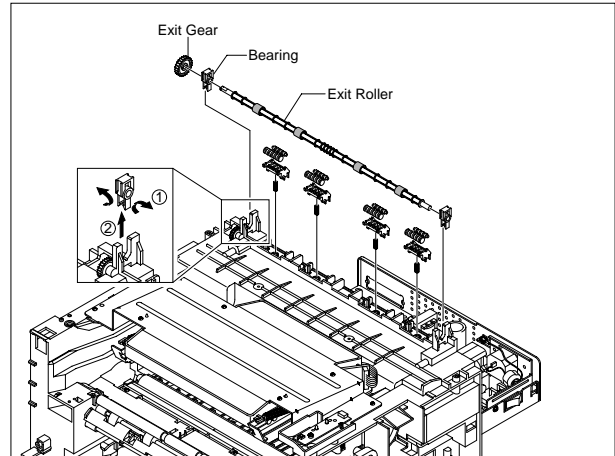

5.5 LSU

1. Before you remove the Fuser, you should remove:
 - Top Cover(see page 5-2)
2. Remove two screws and unplug one connector from the Frame.

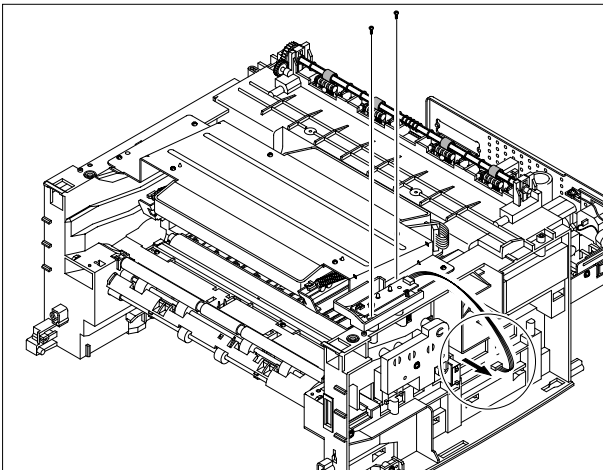

3. Remove the LED PBA Ass'y as shown below.

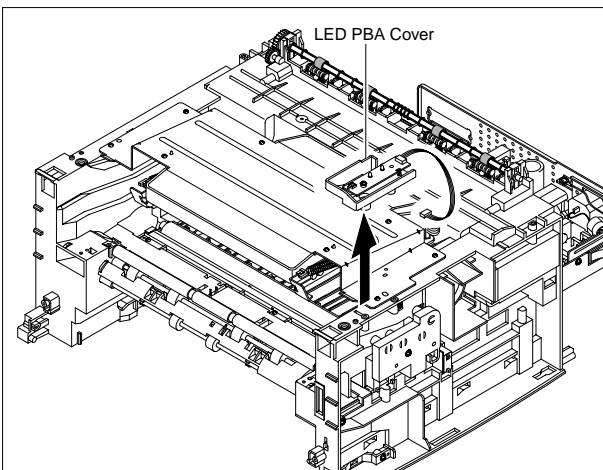

4. Unplug two connector from the LSU

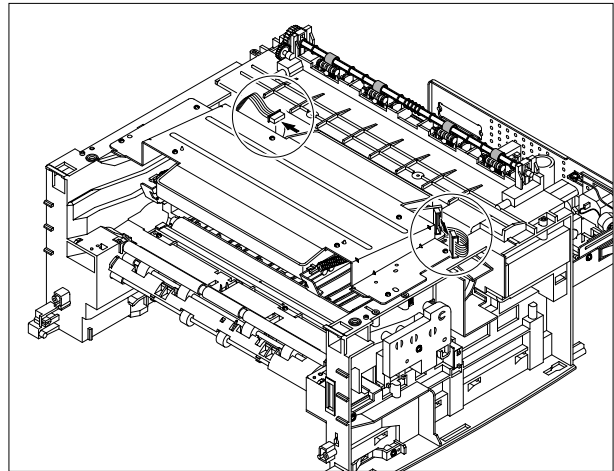

5. Unplug four screws and take the LSU out.

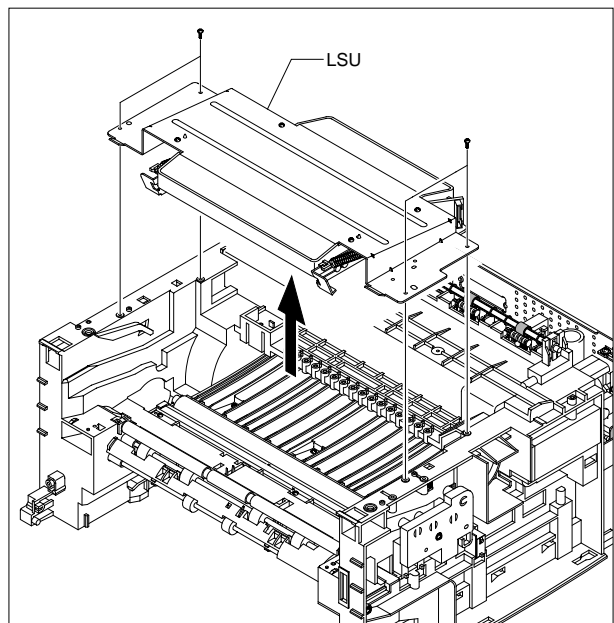

5.6 Fan

1. Before you remove the Fuser, you should remove:
 - Top Cover(see page 5-2)
2. Unplug the connector from the SMPS and remove the one screw. Then take out the Fan.

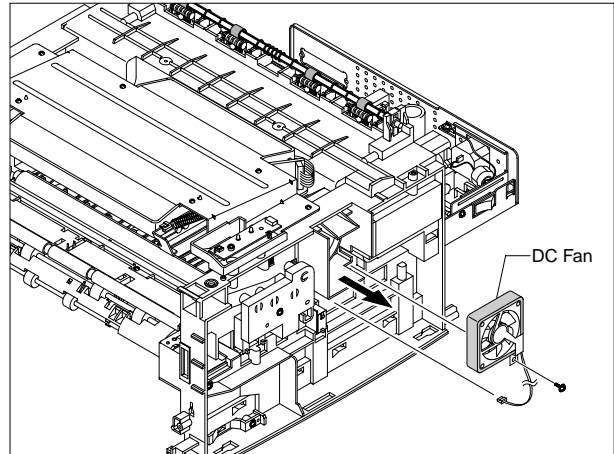

5.7 Driver Ass'y

1. Before you remove the Fuser, you should remove:
 - Top Cover(see page 5-2)
2. Remove the six screws from the Drive Ass'y.

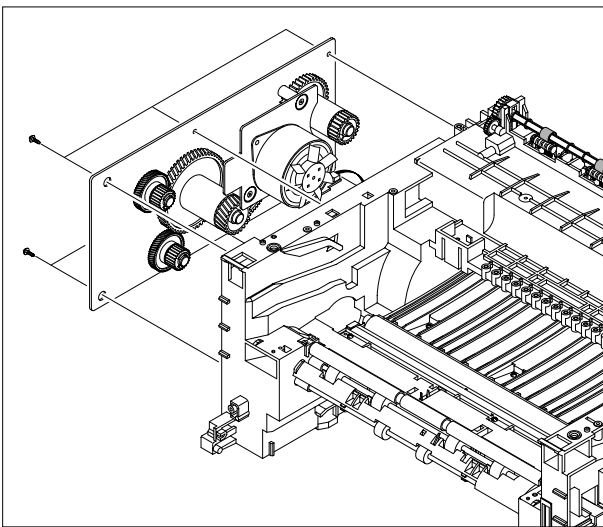

3. Unplug one connector from the Driver Ass'y

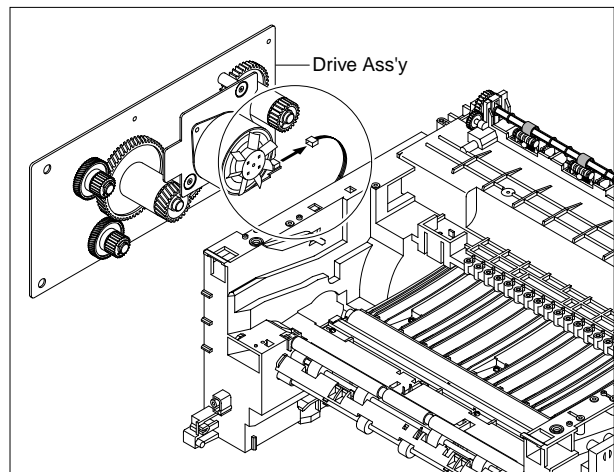

5.8 Engine Shield Ass'y

- Before you remove the Fuser, you should remove:
 - Top Cover(see page 5-2)
 - Fuser Connector(see page 5-3)
- Remove the fourteen screws securing from the Engine Shield Ass'y and unplug the all connectors. Then take the Engine Shield Ass'y.

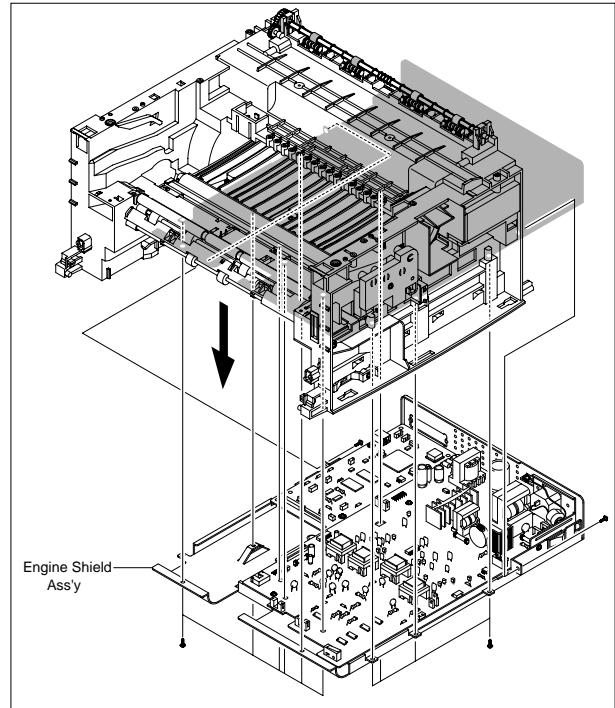

5.9 Main PBA

- Before you remove the Fuser, you should remove:
 - Top Cover(see page 5-2)
 - Engine Shield Ass'y(see page 5-8)
- Unplug one connector and remove five screws from the Main PBA. Then lift the Main PBA out, as shown below.

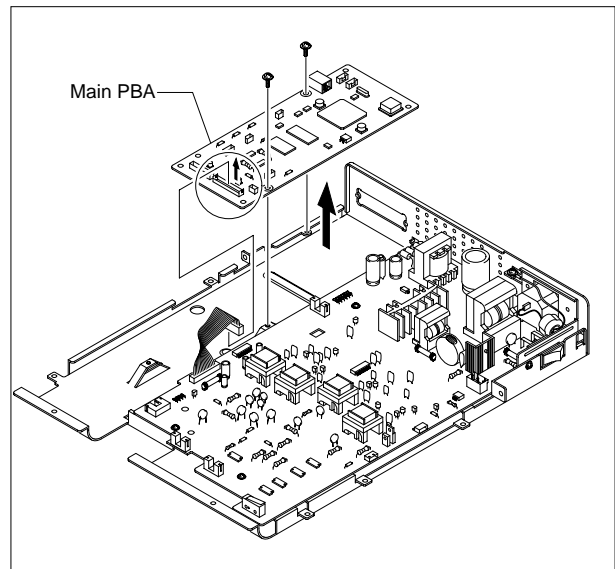

5.10 SMPS

- Before you remove the Fuser, you should remove:
 - Top Cover(see page 5-2)
 - Engine Shield Ass'y(see page 5-8)
- Unplug one connector and remove three screws then take the Inlet Ass'y out.

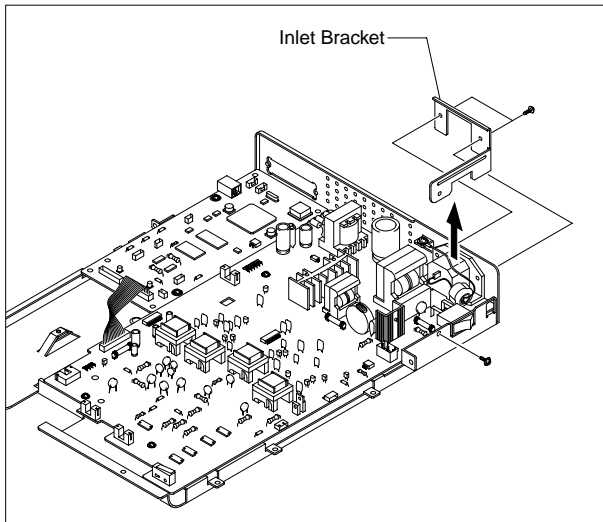

- Remove one screw and unplug one connector from the Main PBA.

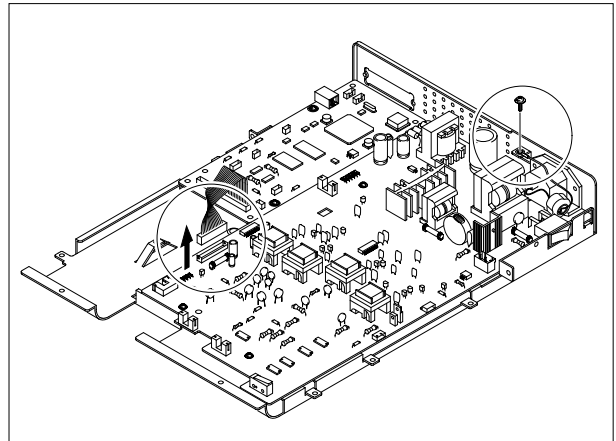

- Remove three screws and take The SMPS out.

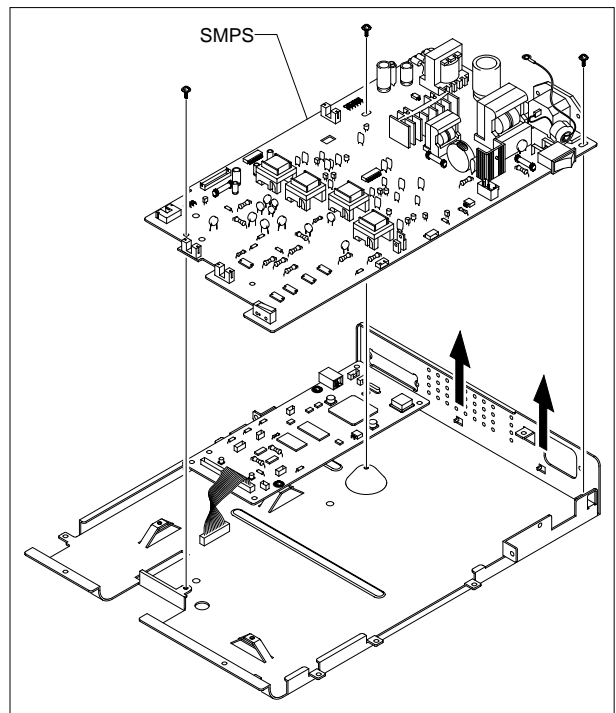

5.11 Transfer Roller

1. Before you remove the Fuser, you should remove:

- Top Cover(see page 5-2)
- LSU(see page 5-6)

2. Remove three screws and take the Transfer Earth out.

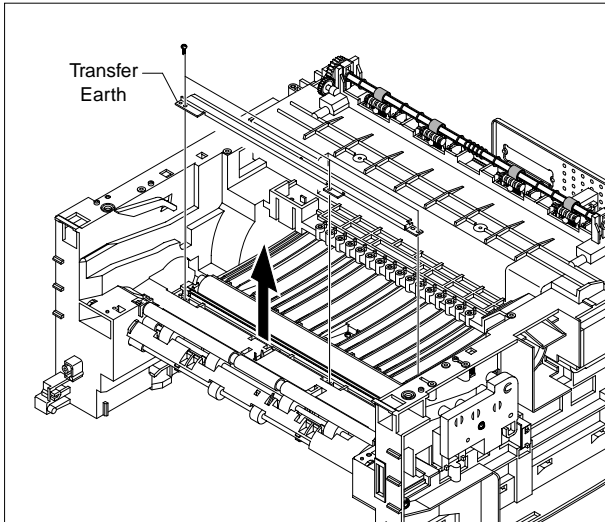

3. Unplug the PTL Holder Connector, then remove the PTL Holder and PTL Lens, as shown below.

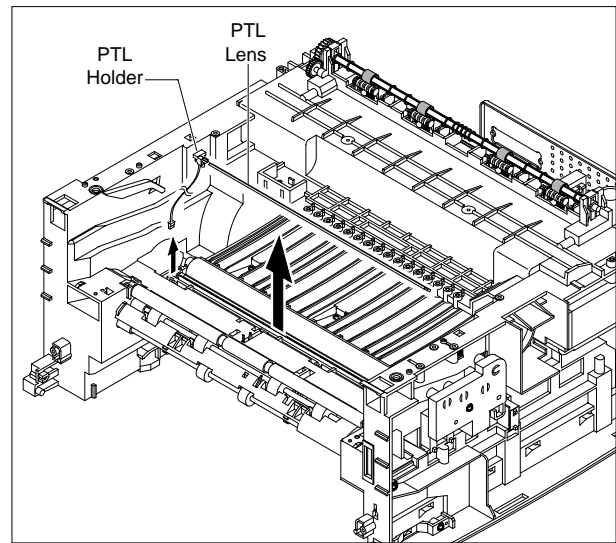

4. Unlatch the Bush and remove it. Then lift the Transfer Roller out, as shown below.

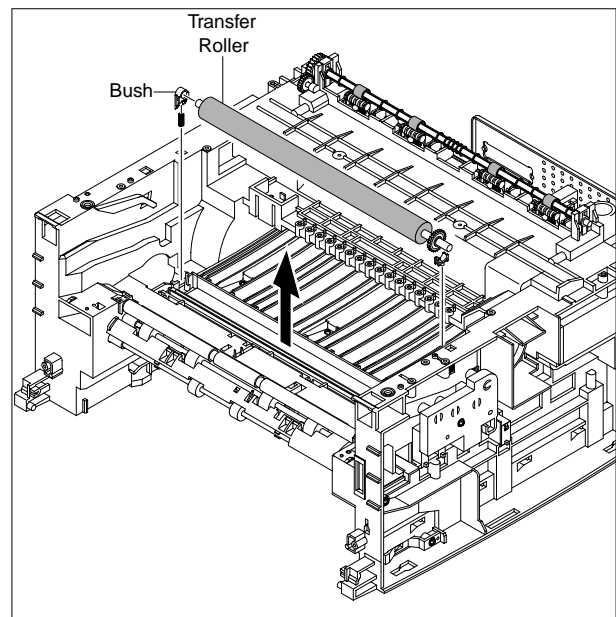

5.12 Feed Roller

1. Before you remove the Fuser, you should remove:

- Top Cover(see page 5-2)
- Drive Ass'y(see page 5-7)

2. Pull up the Feed Idle Bush and Feed Idle Shaft, as shown below.

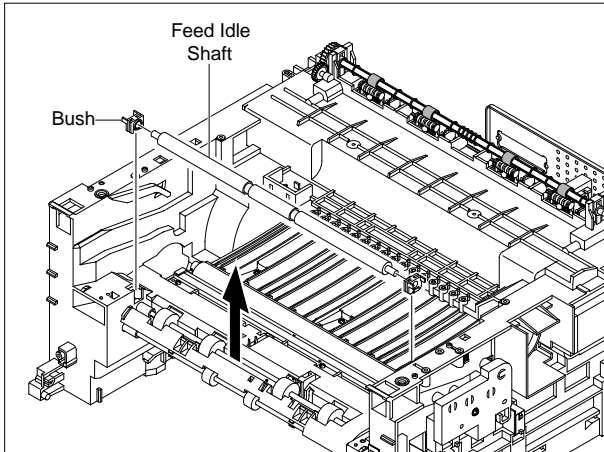

3. Remove three screws from the Feed Bracket and take it out.

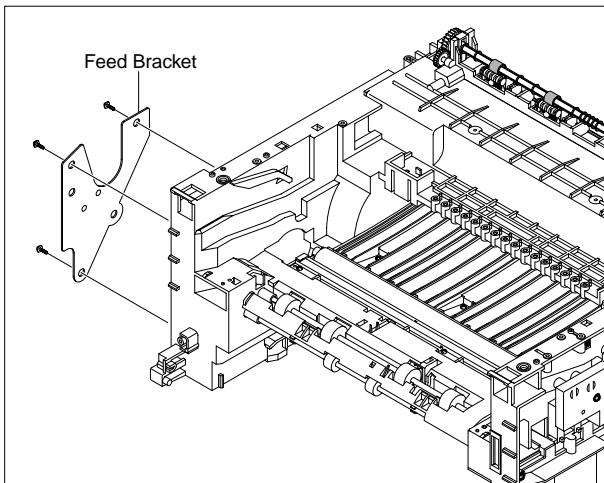

4. Remove the Idle Gear and Feed Gear2.

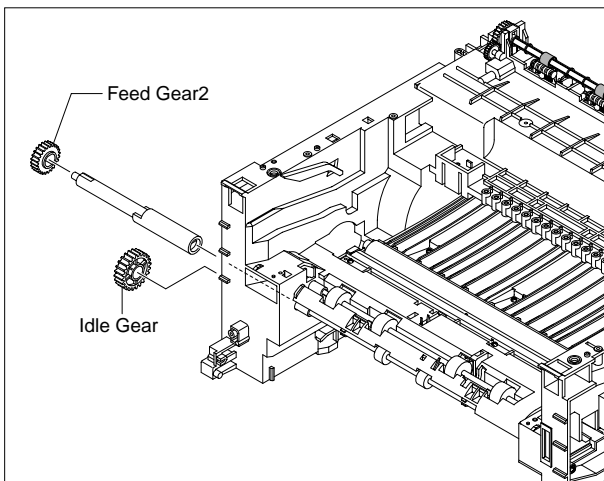

5. Remove the Feed Gear 1 Ass'y, as shown below.

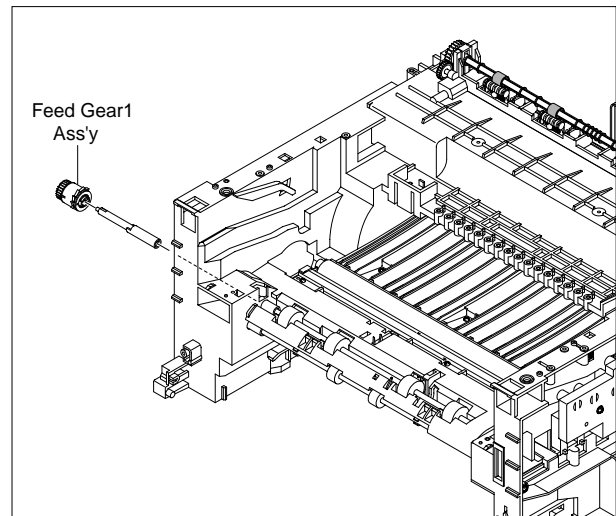

6. Remove the Feed Roller and Feed Roller 1, as shown below.

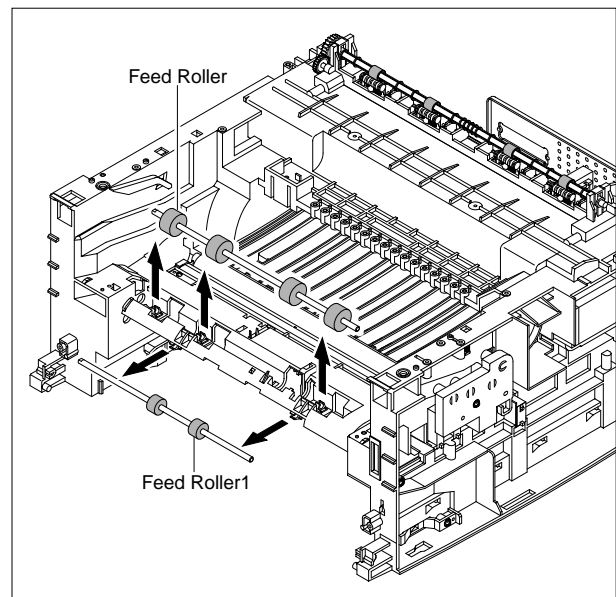

5.13 Pick Up Roller

1. Before you remove the Fuser, you should remove:
 - Top Cover(see page 5-2)
 - Drive Ass'y(see page 5-7)
 - Engine Shield Ass'y(see page 5-8)

2. Remove the Pick up Gear Ass'y, as shown below.

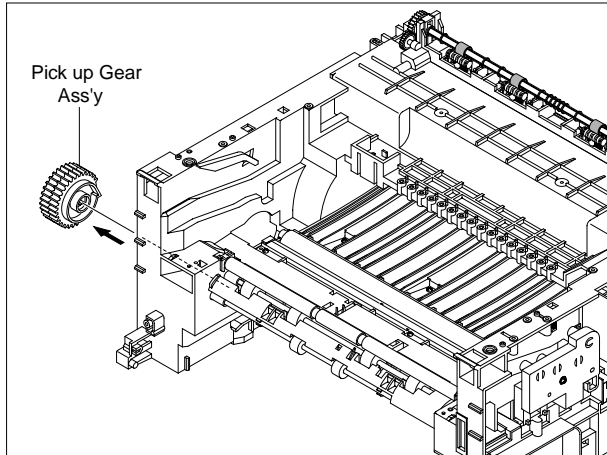

3. Remove the Pick up Ass'y, as shown below.

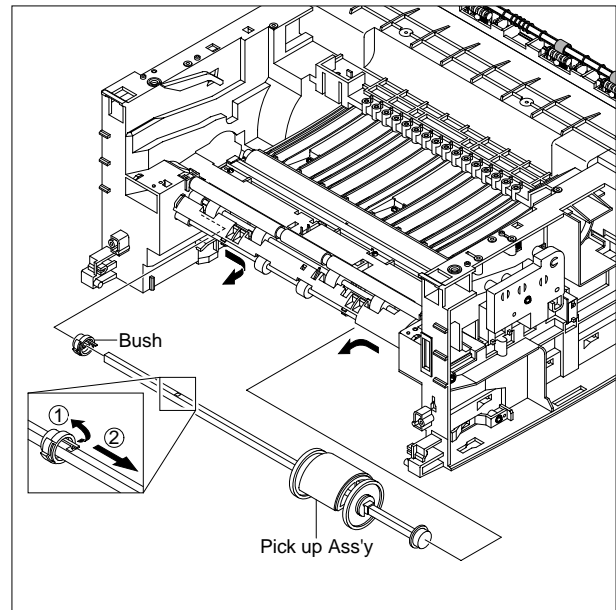

5.14 Solenoid

1. Before you remove the Fuser, you should remove:
 - Top Cover(see page 5-2)
 - Drive Ass'y(see page 5-7)
 - Engine Shield Ass'y(see page 5-8)
 - Pick Up Roller(see page 5-11)

2. Remove two screw then remove The Manual Solenoid and Pick Up Solenoid.

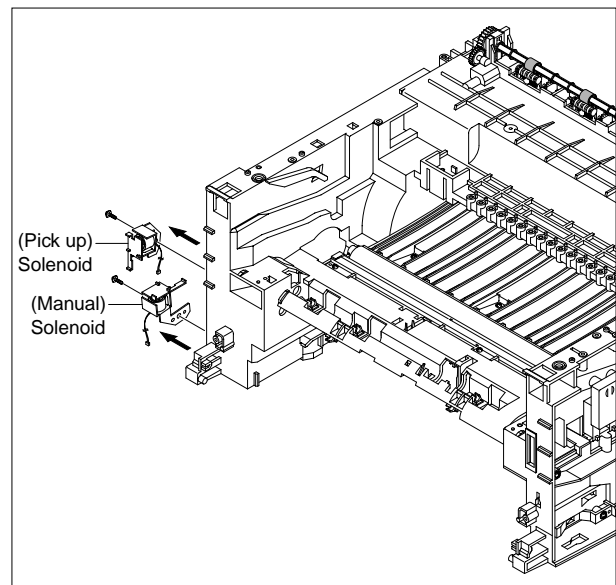

6. Alignment and Adjustments

This chapter describes the main functions for service, such as the product maintenance method, the test output related to maintenance and repair, DCU using method, Jam removing method, and so on. It includes the contents of manual.

6.1 How to use DCU

6.1.1 DCU Setup

You can examine the malfunction of the printer. To perform DCU, open the front discharge cover and leave the connect the harness wire(10 pin/4 pin) to the CN10(4 pin) of the Main control board.





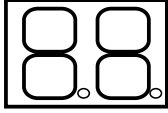

ML SERIES DIAGNOSTIC CONTROL UNIT

STATUS 

DIAGNOSTIC 



04	DEV 300	DEV 350	DEV 350
05	LSU READY	LSU MT & LD	LSU MOTOR
07	PAPER EMPTY	PAPER WIDTH	NEW CRU
08		EXIT SENSOR	FEED SENSOR
09	COVER OPEN		
10	COER HEATING	PRINTING TEMP	READY HEAT
			
	ON	OFF	

SELF TEST 

DIAGNOSTIC CODE	
00	MAIN MOTOR OPERATING SYSTEM
01	MAIN HIGH-VOLTAGE ON
02	TRNSFER HIGH-VOLTAGE (-)ON
03	THV(+) REFERANCE VOLTAGE
04	DEV/SUPPLY HIGH-VOLTAGE ON/PTL ON
05	LSU OPERATING SYSTEM
06	PICKUP CLUTCH ON
07	PEEMPTY/PWITH/NEW CRU TEST
08	FEED & EXIT SENSOR TEST
09	COVER OPEN SENSOR TEST
10	FUSER TEST
11	HOT BURN TEST
12	CLEAN MODE PRINT
13	THV(+)TRIGGER, ALL HV & FAN ON
14	THV(+) REFERENCE ON

STATUS CODE	
61	WARM UP
00	READY (REGAL)
01	READY (LETTER)
02	READY (A4)
03	READY (EXECUTIVE)
04	READY (B5)
20	PRINT START
30	FEED SENSOR ON
40	FEED SENSOR OFF
50	PAPER OUT
69	SLEEP MODE

ERROR STATUS CODE	
60	OPEN FUSER ERROR
62	LOW TEMPERATURE ERROR
68	OVER HEATING ERROR
64	COVER OPEN ERROR
70	NO PAPERR
71	PAPER JAM 0
72	PAPER JAM 1
73	PAPER JAM 2
95	LSU NOT READY

DIAGNOSTIC MODE

DOWN UP



SHIFT



STOP ENTER



TO ENTER DIAGNOSTIC MODE, PUSH THREE BUTTONS SIMUL ANEOUSL AND TURN THE PRINTER POWER ON.

6.1.2 Code

Connect DCU to the printer and turn the power on. It show 7 Segment FND on the panel and each code tells the function of the printer.

1) Normal Code

While printing or warming up, it indicate the position of the paper

Code	State	Description
61	Warm up	The printer is on, the cover is open or close.
00~05	Ready(kind of paper)	The printer is ready, the paper is detected when the first paper is printed. 00: Legal ,01: Letter ,02: A4 ,03: EXEC ,04: B5 ,05: Folio, 06: A5/A6
20, 21, 22	Print Start	The engine controller received the print order from the video controller. 20: 1st, 21: MP, 22: SCF
30	Feed Sensor On	The paper is passing out of the Feed Sensor.
40	Feed Sensor off	The paper has passed out of the Feed Sensor.
50	Paper Out	The paper has passed out of Exit Sensor.
69	Sleep Mode	The fuser power turned off to minimize the power consumption.

2) Error Code

When detecting the malfunction, the printing is stopped to indicate error code.

Code	State	Description
60, 62, 68	Fuser Error	The error in the fuser occurred. There is a short circuit in the thermistor and the thermostat while printing, Low Temperature Error occurs. • 60: Open Fuser Error • 62: Low Heat Error • 68: Over Heat Error
64	Cover Open	The Printer Cover is open.
65	CRU Error	The Toner Cartridge not installed,
70	No Paper	No paper in the paper cassette.
71	Paper Jam 0	The front part of paper is jammed between pickup unit and Feed sensor.
72	Paper Jam 1	The front part of paper is jammed between the Discharge sensor and Feed sensor.
73	Paper Jam 2	The front part of paper is jammed just after passing through the discharge sensor.
76	Out Bin Full	The Out bin is filled with paper.
95	LSU Not Ready	LSU Scanner Motor not ready or Hsync signal not output.

6.1.3 Self Diagnostic Mode

If Error code occurs due to malfunction of the printer, perform Self Diagnostic Mode to solve the problem.

The printer works only in the self-test mode to solve the malfunction problem.

To enter the self-test mode, turn the power on pressing the buttons of [Down], [Shift] and [Stop] at the same time.

Release the button within 2 or 3 seconds if 78 shows in the DCU. If 00 shows in the DCU, press the button [Up] or [Shift] to select the self+test , and press the button of [Enter] to operate. To stop, press the button of [shift] and [Enter] together.

Code	Description
00	Main Motor Operating System Only the main motor is in operation.
01	Main High Voltage On(THV-) -1400 voltage output by MHV terminal. <i>Caution : High voltage probe should be used.</i>
02	Transfer High Voltage(-)On(THV-) -1000 voltage output by MHV terminal. Caution : High voltage probe should be used.
03	Transfer High Voltage (+)Reference on (THV +) +800 voltage output by MHV terminal. <i>Caution : High voltage probe should be used.</i>
04	DEV/supply High Voltage : DEV/Supply High Voltage Test. The left one of the three LEDs in the self-test panel is on when DEV high voltage Supply high voltage output by each HV terminal(-500V). Press the [Up] button to switch the voltage. The middle and right one of the three LEDs are on and -650 voltage output by DEV HV terminal. <i>Caution : High voltage probe should be used.</i>
05	LSU Operating System The scanning motor of LSU is in operation, the right LED of the three buttons on. Press the [Up] button to Check LD. LD is functioning and the middle button is on. If the LD is normal, all LEDs are on.
06	Pickup clutch on The Solenoid in the printer is in operation. To stop the operation, Press the button [shift] and [Enter] together.

Code	Description
07	<p>Paper Empty Sensor Test :</p> <p>If activate the Actuator of the PEMPTY Sensor, the left and right of the three LEDs are on.</p> <p>Paper Empty Sensor ON/OFF 1st LED ON/OFF</p>
08	<p>Feed & Exit Sensor Test</p> <p>Test the Feed sensor and Discharge sensor in the same way as '07'.</p> <p>Feed Sensor ON/OFF 2nd LED ON/OFF</p> <p>Exit Sensor ON/OFF 3rd LED ON/OFF</p>
09	<p>Cover Open Sensor Test</p> <p>Test the Cover Open Sensor in th same way as code '07'</p> <p>Cover Open Sensor ON/OFF 1st LED ON/OFF</p>
10	<p>Fuser Test</p> <p>If the [Enter] button pressed, the right LED is on and temperature of the fuser is up to READY Mode. If the [Up] button pressed, the middle LED is on and temperature of the fuser is up to Printing Mode.</p> <p>If you press the button once more, the left LED is on and temperature of the fuser is up to overheat Mode.</p>
11	<p>Hot Burn Test</p> <p>If the [enter] button pressed, the printer is continuously printing without detection. Turn the power off to stop operation.</p>
12	<p>Cleaning Mode Print Mode</p> <p>Print the paper to clean the OPC Drum in the Cartridge.</p>
13	<p>THV(+) TRIGGER. ALL HV :</p> <p>All high voltage output by each HV terminal and LSU and the fan is in operation. In this mode, electronic resistance of transfer roller and high voltage is detected.</p>
14	<p>PTL Test :</p> <p>Indicates the function of the PTL, same method of the code '07'.</p>
15	<p>Fan Test :</p> <p>Indicates the function of the Fan, same method of the code '07'.</p>
16	<p>Manual Pickup Test :</p> <p>Indicates the function of th Manual Pickup, same method of the code '07'.</p>
17	<p>Manual Sensor Test :</p> <p>Indicates the function of the Manual Sensor, same method of the code '07'.</p>

6.1.4 Self Test Button

If the Self-Test button pressed, vertical lines are printed.

Turn the power on while pressing this button, '89' shows in the DCU and the printer is warming up. After warming-up the printer is in READY Mode, and '88' shows in the DCU. In this mode, without any detection, the printer begins printing(trial printing and data from the PC). It is convenient to use this mode when the engine malfunction is detected in the control board.

6.2 Paper Path

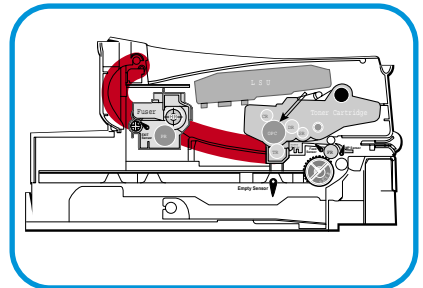
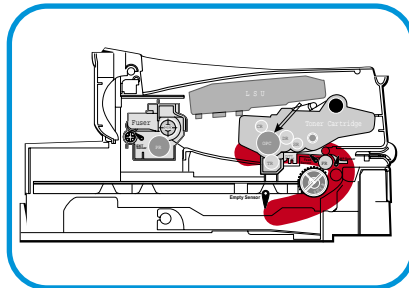
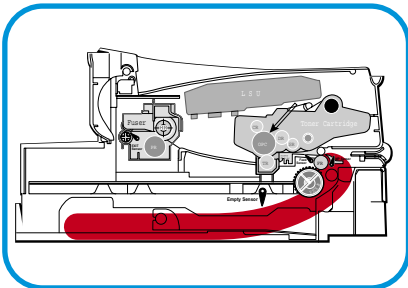
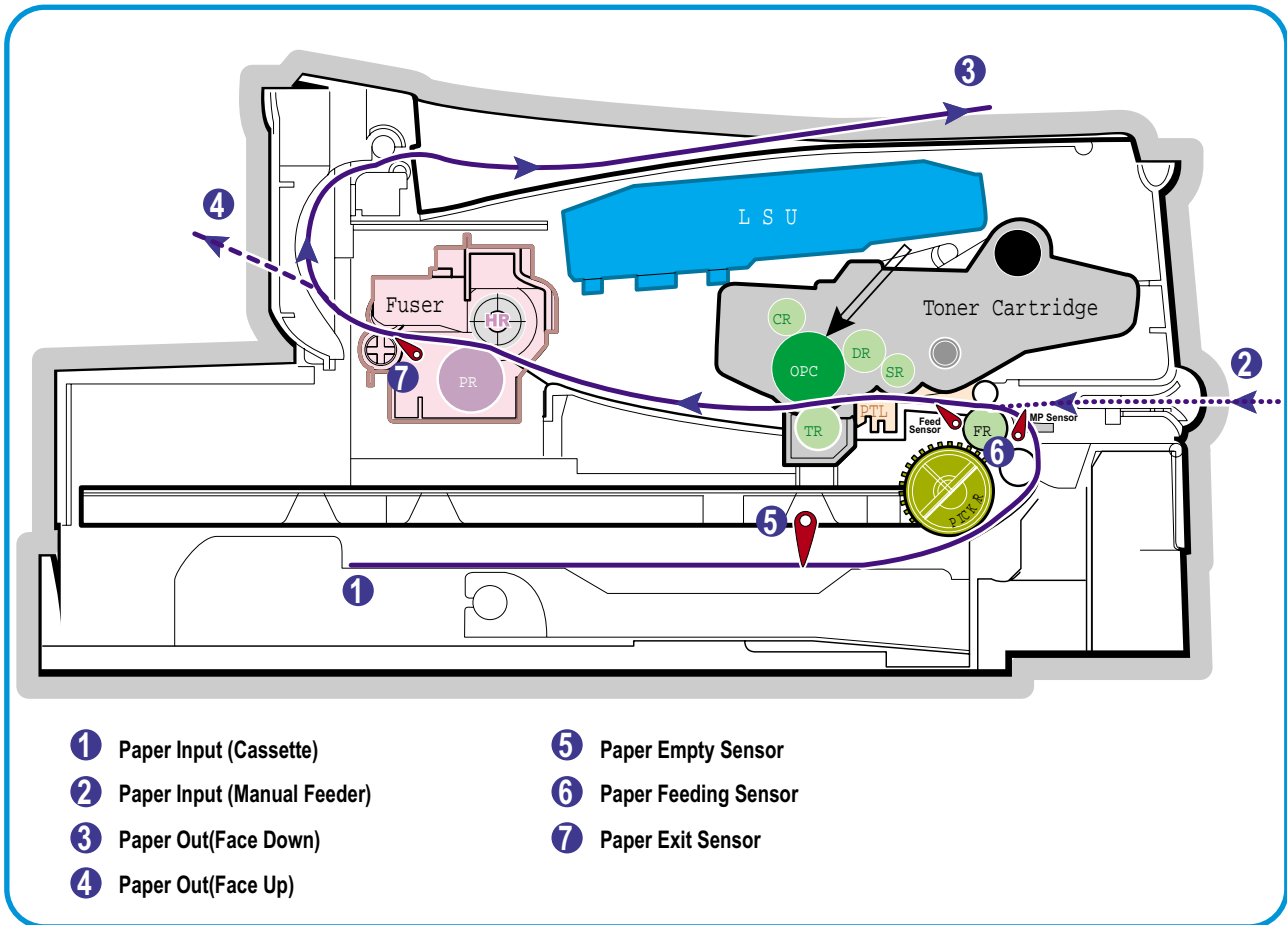

- 1) After taking order, the printer feeds the printing paper from the cassette or manual feeder.
- 2) The paper passes the paper feeding sensor. (Jam 0 occurs if the sensor is not operated after certain time passes)
- 3) The paper passes the paper feeding sensor and moves to the paper exit sensor via the printing process. (Jam 1 occurs if the sensor is not operated after certain time passes)
- 4) The paper passes the paper exit sensor and moves out from the set. (Jam 2 occurs sometime after if the trailing edge of the paper is not coming out from the set after the leading edge of paper passes the paper exit sensor.)

6.3 Clearing Paper Jams

Occasionally, paper can be jammed during a print job. Some of causes include:

- The tray is loaded improperly or overfilled.
- The tray has been pulled out during a print job.
- The front cover has been opened during a print job.
- Paper that does not meet paper specifications has been used.
- Paper that is outside of the supported size range has been used.

If a paper jam occurs, the On Line/Error LED on the control panel lights red. Find and remove the jammed paper. If it is invisible, look inside the printer.

6.3.1 In the Paper Exit Area (JAM2)

- 1) If the paper jams as it exits to the output tray and a long portion of the paper is visible, pull the paper straight out.
- 3) Loosen the paper if it is caught in the feed rollers. Then pull the paper gently out.

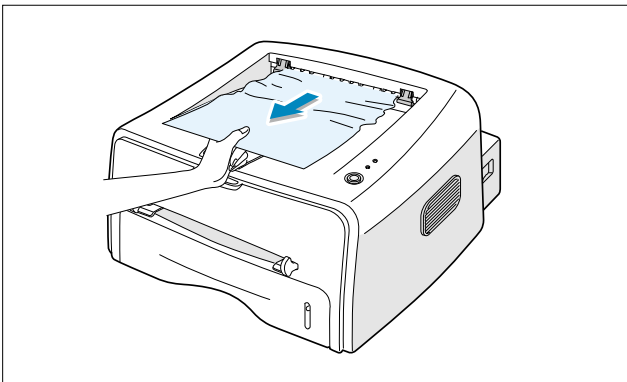

When you pull the jammed paper, if there is resistance and the paper does not move immediately, stop pulling. Continue with the next step.

- 2) Open the rear output tray.

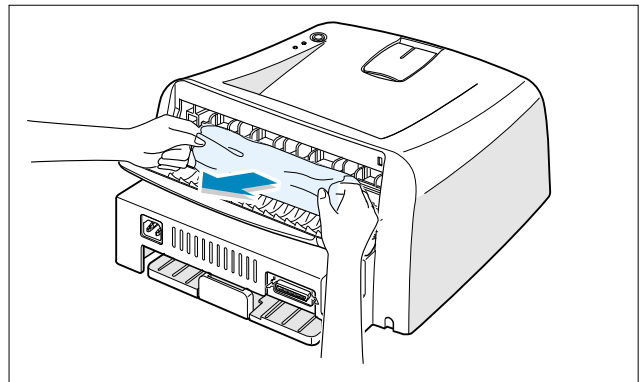
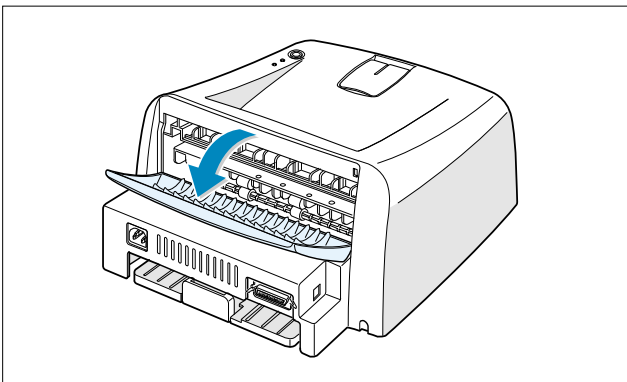

Note: Please be careful when you open the rear cover. The inside of the printer is still hot.

- 4) Close the rear output tray. Open and close the front cover. Printing can be resumed.

6.3.2 In the Paper Feed Area (JAM0)

1) Slide out the tray to expose the jammed paper.

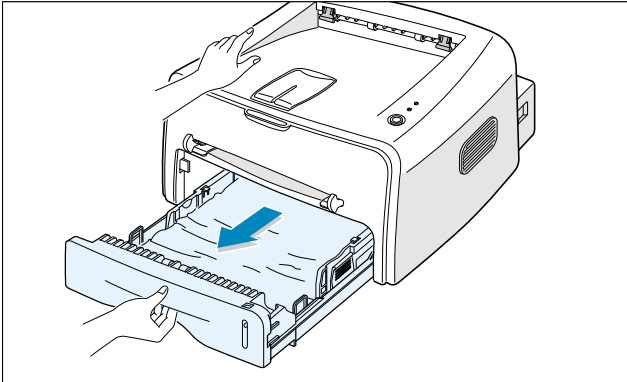

2) Remove any missfeed paper by pulling it out by the visible edge from the tray. Make sure that all of the paper is properly aligned in the tray.

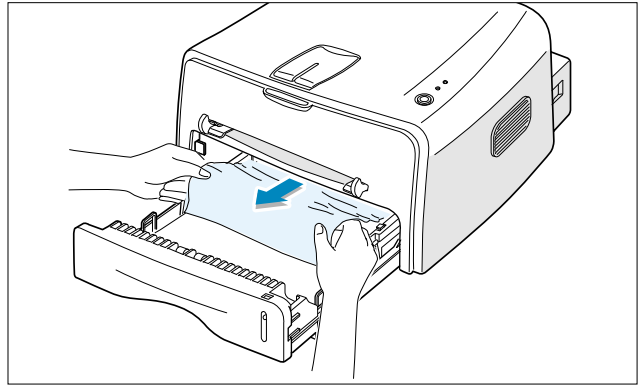

3) Slide the tray back into the printer. Open and close the front cover. Printing can be resumed.

6.3.3 Around the Toner Cartridge (JAM1)

1) Open the front cover and remove the toner cartridge

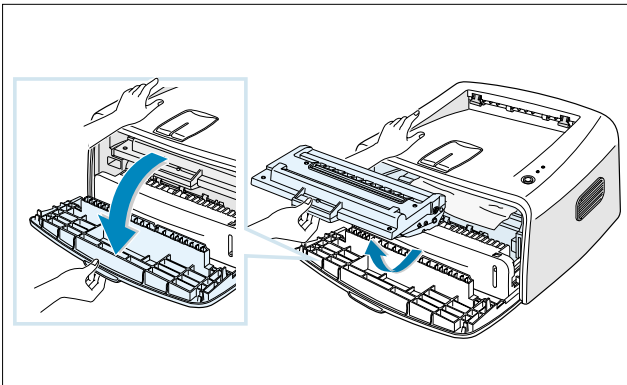

2) Gently pull the paper toward you.

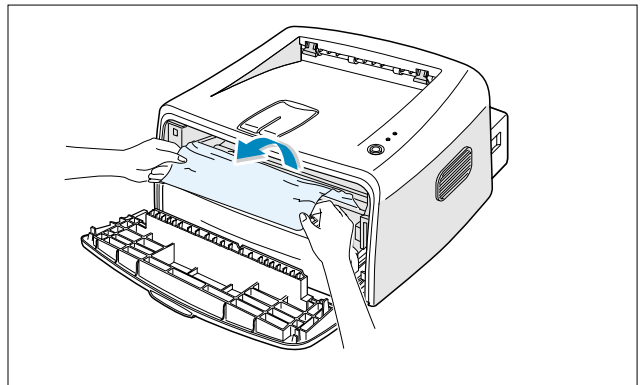

3) Check that there is no other paper in the printer.

4) Reinstall the toner cartridge, and then close the cover. Printing can be resumed.

3.3.4 Tips for Avoiding Paper Jams

By selecting the correct paper types, most paper jams can be avoided. If a paper jam occurs, follow the steps outlined in

- Ensure that the adjustable guides are positioned correctly.
- Do not overload the tray. Ensure that the paper is below the paper capacity mark on the right inside of the tray.
- Do not remove the paper from the tray while printing.
- Flex, fan and straighten the paper before loading.
- Do not use creased, damp or highly curled paper.
- Do not mix paper types in the input tray.
- Use only recommended print media.
- Ensure that the recommended print side is facing down when loading paper into the input tray.

6.4 Sample Pattern

This product has the several sample patterns for maintenance. With the sample patterns, check the existence of the abnormality. The patterns help to regularly maintain the product.

6.4.1 Printing a Demo Page

Print a demo page or a configuration sheet to make sure that the printer is operating correctly.

- 1) Hold down the Cancel button for about 2 seconds to print a demo page.
Hold down the Cancel button for about 6 seconds to print a configuration sheet.

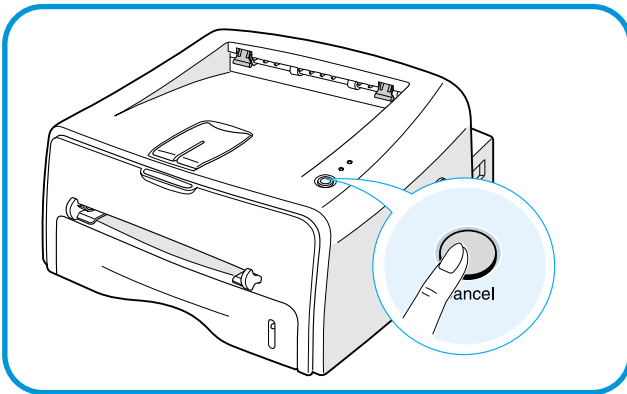

- 2) The Demo page or the configuration sheet shows the printer's current configuration.

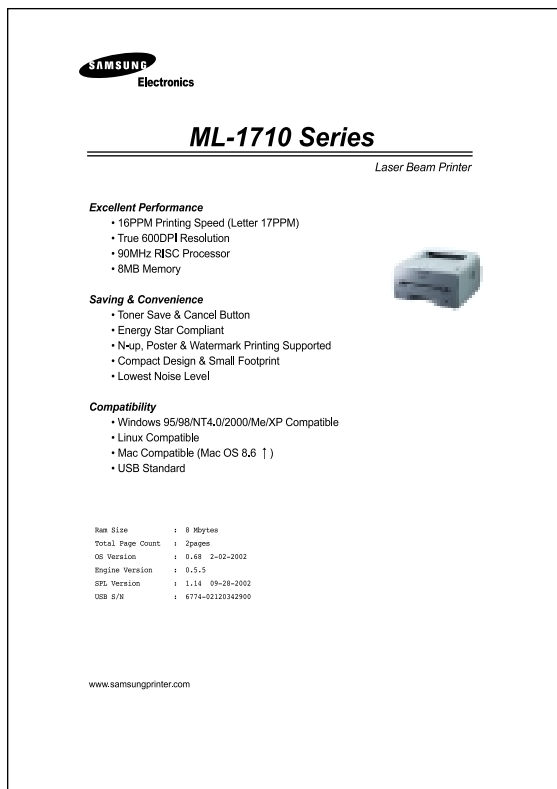

<Demo Page : ML-1710>



<Demo Page : ML-1750>

Samsung ML-1750/ML-1760 Series**SAMSUNG****Menu Map****Paper Menu**

Tray Source = Auto
Media Size = A4
Media Type = off

Layout Menu

Orient = Portrait
Top Margin = 0.0
Left Margin = 0.0
Copies = 1

Graphics Menu

Resolution = 600dpi-Normal
Image Enhance = Enhance
Toner Save = Off
Density = Medium
Dark Text = Off

Setup Menu

Emulation = Auto
Power Save = 5 Minutes
Auto Continue = On
Jam Recovery = Off
Altitude Adj. = Low
Auto CR = LF
Job Timeout = 15

PCL Menu

Typeface = Courier SWC
Symbol =
PC8
Lines = 64
Pitch = 10,00
Courier = Regular

Configuration Sheet

RAM Size : 8MBytes
Total Page Count : 2185 pages
OS Version : 0.91H 12-04-2002
Engine Version : 0.4.6

USB SN : drvswgeu.c 975
PCL5e Version : 1.59 10-23-2002
PCL6 Version : 3.09 09-16-2002
SPL Version : 1.14 11-21-2002

Options

Option Tray Not Installed
Usb Connection : Not connected

<System Data List : PCL Model Only>

6.4.2 Printing a cleaning sheet

If you are experiencing blurred, faded or smeared printouts. Printing a cleaning sheet cleans the drum inside the toner cartridge. This process will produce a page with toner debris, which should be discarded.

- 1) Ensure that the printer is turned on and in the Ready mode with paper loaded in the tray.

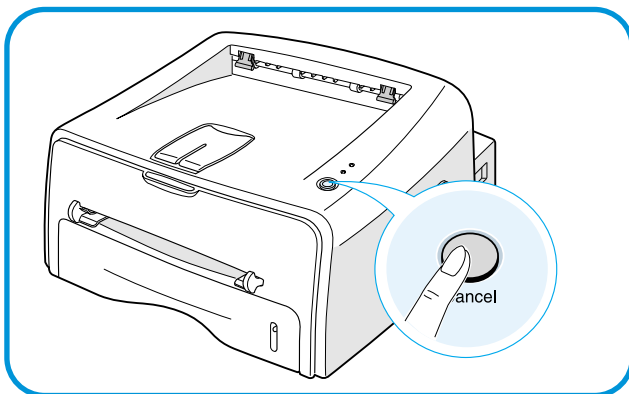

- 2) Press and hold down the Cancel button on the control panel for about 10 seconds.
- 3) Your printer automatically picks up a sheet of paper from the tray and prints out a cleaning sheet with dust or toner particles on it.

Note: The cartridge cleaning process takes some time. To stop printing, turn the power off.

6.5 Consumables and Replacement Parts

The cycle period outlined below is a general guideline for maintenance.
The example list is for an average usage of 50 transmitted and received documents per day.
Environmental conditions and actual use will vary these factors.
The cycle period given below is for reference only.

COMPONENT	REPLACEMENT CYCLE
Pick-up Roller	60,000 Pages
PaepR Feeding Roller(Friction Pad)	60,000 Pages
Transfer Roller	60,000 Pages
Fuser	60,000 Pages
Toner Cartridge	3,000 Pages

6.6 Periodic Defective Image

If the delinquent image regularly occurs in the printed-paper, it is due to delinquent or damaged roller. Refer to the table in below and check the condition of the roller.

No	Roller	Defective image	Typical defect
1	OPC Drum	75.5mm	white spot on black image
2	Charge Roller	37.7mm	black spot
3	Supply Roller	37.0mm	light or dark horizontal image band
4	Developing Roller	35.3mm	horizontal image band
5	Transfer Roller	45.3mm	image ghost
6	Heat Roller	64.1mm	Black spot and image ghost
7	Pressure Roller	75.5mm	black spot on the backside

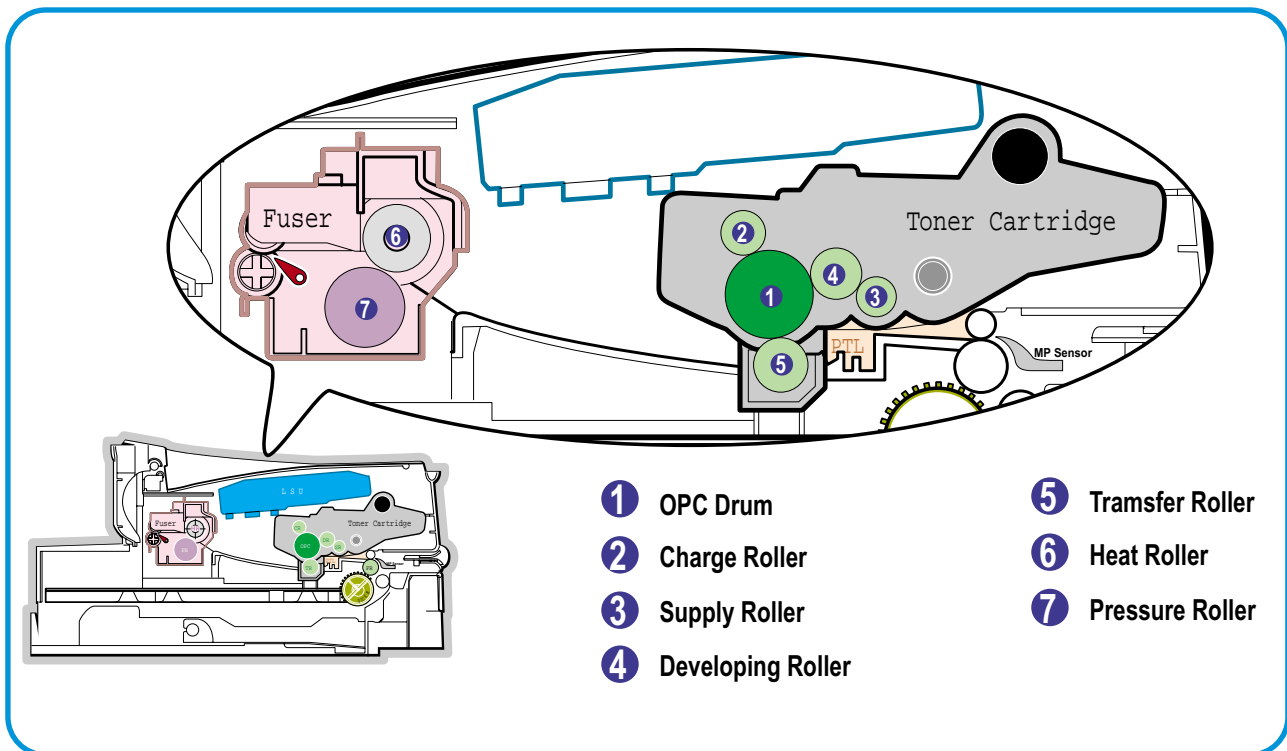

<Rollers Layout>

Memo

7. Troubleshooting

7.1 Bad image

7.1.1 Vertical Black Line and Band

• **Description**

1. Straight thin black vertical line occurs in the printing.
2. Dark black vertical band occur in the printing.



Check and Cause	Solution
<ol style="list-style-type: none"> 1. Damaged develop roller in the Developer. Deformed Doctor-blade or cleaning-blade. 2. Scratched surface of the discharge roller in the developer. 3. Partly depression or deformation on the surface of the transfer roller. 	<ol style="list-style-type: none"> 1. If causes 1 and 2 occur in the developer cartridge, replace the developer and try to print out. 2. Replace the transfer roller if occurred as No. 3.

7.1.2 Vertical White Line

• **Description**

White vertical voids in the image.



Check and Cause	Solution
<ol style="list-style-type: none"> 1. Foreign matter stuck onto the window of internal lenses of LSU mirror. 2. Foreign matter or toner particles between the developer roller and blade. (In case the life of the developer has been expired, white lines or light image occur in front of the image.) 3. It may occur when Burr and foreign substances are on the window of the developer frame. 4. If the fuser is defective, voids occur periodically at the top of a black image. 	<ol style="list-style-type: none"> 1. Foreign matter stuck onto the window : Clean the LSU window with recommended cleaner(IPA) Clean the window with a clean cotton swab. 2. Foreign matter in the LSU : Open the cover of LSU and clean with a cotton swab on the surface of the reflex mirror. 3. No 3. : Remove the foreign matter and burr of the exposure window. (Developer cartridge) 4. No. 4. : Open the front cover and check ribs that corresponds to the position of the voids. Remove if found. 5. If the problems are not solved, replace the developer cartridge.

7.1.3 Horizontal Black Band

- **Description** 1. Dark or blurry horizontal stripes occur in the printing periodically.
(They may not occur periodically.)

Check and Cause	Solution
<p>1. Bad contacts of the voltage terminals to developer.</p> <p>2. The rollers of developer may be stained. Charge roller = 37.7mm Supply roller = 37mm Develop roller = 35.3mm Transfer roller = 45.3mm</p>	<p>1. Clean each voltage terminal of the Charge, Supply, Develop and Transfer roller. (remove the toner particles and paper particles)</p> <p>2. Clean the right Gear that has relatively small gap of the teeth in the OPC.</p> <p>3. If the malfunction persists, replace the developer.</p>



7.1.4 Black/White Spot

- **Description** 1. Dark or blurry black spots occur periodically in the printing.
2. White spots occur periodically in the printing.

Check and Cause	Solution
<p>1. If dark or blurry black spots occur periodically, the rollers in the Developer may be contaminated with foreign matter or paper particles. (Charge roller : 37.7 mm interval OPC drum : 75.5 mm interval)</p> <p>2. If faded areas or voids occur in a black image at intervals of 75.5 mm, or black spots occur elsewhere, the OPC drum surface is damaged.</p> <p>3. If a black image is partially broken, the transfer voltage is abnormal or the transfer roller's life has expired.</p>	<p>1. Run OPC cleaning Mode Print and run the Self-test 2 or 3 times.</p> <p>2. In case of 75.5 mm interval unremovable in 1, cleanly remove foreign substances stuck on the OPC location equivalent to black spots and white spots with a dry duster.</p> <p>3. The transfer roller guarantees 60,000 sheets printing. If the roller's life is expired, replace it.</p> <p>4. In case of 37.7 mm interval unremovable in 1, take measures as to replace the developer cartridge and try to print out.</p> <p>5. Clean the inside of the set against the paper particles and foreign matter in order not to cause the trouble.</p>



7.1.5 Light Image

- **Description** The printed image is light, with no ghost.

Digital Printer
Digital Printer
Digital Printer
Digital Printer
Digital Printer

Check and Cause	Solution
1. Develop roller is stained when the toner of developer cartridge is almost consumed.	1. Check if the Toner Save mode is off.
2. Ambient temperature is below than 10°C.	2. Replace the developer cartridge and try to print out.
3. Bad contact caused by the toner stains between the high voltage terminal in the HVPS and the one in the set.	3. Wait 30 minutes after printer is powered on before you start printing.
4. Abnormal output from the HVPS.	4. Clean up the contaminated area by the toner.
	5. Replace the HVPS if the problems are not solved by the above four directions.

7.1.6 Dark Image or a Black

- **Description** The printed image is dark.



Check and Cause	Solution
1. No charge voltage in the engine board. (Perform DCU diagnostic code 01)	1. Clean the high voltage charge terminal.
2. Charge voltage is not turned on due to the bad contacts between power supply in the side of the Developer and charge terminal of HVPS.	2. Check the state of the connector which connects the engine board and HVPS.
	3. Replace the HVPS if not solved by the above direction 1 and 2.

7.1.7 Uneven Density

- **Description** Print density is uneven between left and right.

Digital Printer
Digital Printer
Digital Printer
Digital Printer
Digital Printer

Check and Cause	Solution
<ol style="list-style-type: none"> 1. The pressure force on the left and right springs of the transfer roller is not even, the springs are damaged, the transfer roller is improperly installed, or the transfer roller bushing or holder is damaged. 2. The toner level is not even on the developer roller due to the bad blade. 	<ol style="list-style-type: none"> 1. Replace both the left and right Spring Holder. 2. Occur in the developer cartridge, replace the developer and try to print out.

7.1.8 Background

- **Description** Light dark background appears in whole area of the printing.

Digital Printer
Digital Printer
Digital Printer
Digital Printer
Digital Printer

Check and Cause	Solution
<ol style="list-style-type: none"> 1. Does character exist less than 2% per a page, and hasn't it been used long time? 2. Does recycle paper be used? 3. Has the life span of the developer ended? 4. Is the movement(Up and Down) of the transfer roller smooth? 5. Is the HVPS normal? 	<ol style="list-style-type: none"> 1. The toner cartridge is basically designed to print 3,000 sheets with 5% image. If it prints more than 3,000 sheets (around 5,000 sheets) with 2% image, a background can be occurred. 2. The B/S is not guaranteed if using recycle paper. 3. Replace the developer when the life span of it has been ended. 4. Clean the bushing part of the transfer roller. 5. If the problem is still not solved, replace the developer.

7.1.9 Ghost (1)

- **Description** Ghost occurs at 75.5 mm intervals of the OPC drum in the whole printing.

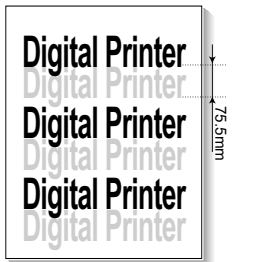
	Check and Cause	Solution
	<ol style="list-style-type: none"> 1. Bad contacts caused by contamination from toner particles between high voltage terminal in the main body and the electrode of the Developer. 2. Bad contacts caused by contamination from toner particles between high voltage terminal in the main body and the one in the HVPS board. 3. The life of developer is expired. 4. Transfer roller lifetime(60.000 sheets) has expired. 5. Abnormal low temperature(below 10°C). 	<ol style="list-style-type: none"> 1. Clean the terminals when contaminated by toner particles. 2. Occur in the developer cartridge, replace the developer and try to print out. 3. Replace the engine board if not solved by the above directions 1-2. 4. If not solved by the direction 3, check the transfer roller lifetime and replace it. 5. Wait about 1 hour after power on before using printer.

7.1.10 Ghost (2)

- **Description** Ghost occurs at 75.5 mm intervals of the OPC drum in the whole printing. (When printing on card stock or transparencies using manual feeder)

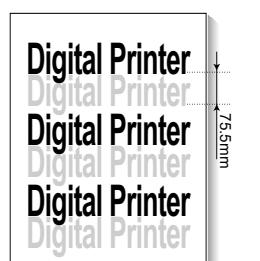
	Check and Cause	Solution
	<p>When printing on card stock thicker than normal paper or transparencies such as OHP, higher transfer voltage is required.</p>	<p>Select 'Thick Mode' on paper type menu from the software application and after using returning to the original mode is recommended.</p>

7.1.11 Ghost (3)

- **Description** White ghost occurs in the black image printing at 32mm intervals.



Check and Cause	Solution
1. The life of the developer may be expired.	1. Occur in the developer cartridge, replace the developer and try to print out.
2. The abnormal voltage and bad contact of the terminal of the supply roller	2. Check the approved voltage of the supply roller and contact of the terminal and adjust if necessary.

7.1.12 Ghost (4)

- **Description** Ghost occurs at 47 mm intervals.



Check and Cause	Solution
The temperature of the fuser is maintained high.	1. Disassemble the fuser and remove the contaminated toner particles on the roller and clean the foreign matter between Thermistor and Heat roller. (▲ Caution : can be deformed)

7.1.13 Satins on the Face of Page

- **Description** The background on the face of the printed page is stained.



Check and Cause	Solution
1. Toner leakage due to improperly sealed developer.	1. Replace the developer cartridge.
2. If the transfer roller is contaminated, satins on the face of page will occur.	2. If the transfer roller is contaminated, run PC Cleaning Mode Print 2 or 3 times. And perform Self-Test 2 or 3 times to remove contamination.

7.1.14 Satins on Back of Page

- **Description** The back of the page is stained at 47 mm intervals.

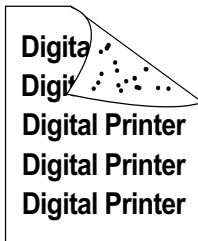

Check and Cause	Solution
1. Transfer roller is contaminated.	1. Perform the OPC Cleaning Mode Print 2 or 3 times. Run Self-Test to remove the contamination of the transfer roller.
2. Pressure roller is contaminated.	2. Replace the transfer roller if contaminated severely.
	3. Disassemble the fuser and clean the H/R(Heat Roller) and P/R(Pressure roller). And check the area between H/R and Thermistor. If contaminated, clean the area not to be deformed.

7.1.15 Blank Page Print out (1)

- **Description** Blank page is printed.

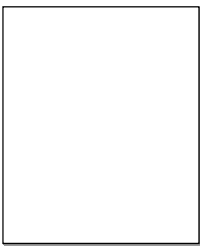

Check and Cause	Solution
Bad ground contacts in OPC and/or developer.	Remove contamination of the terminals of the developer and the unit.

7.1.16 Blank Page Print out (2)

- **Description**
 1. Blank page is printed.
 2. One or several blank pages are printed.
 3. When the printer turns on, several blank pages print.

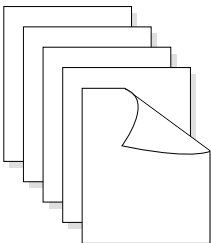

Check and Cause	Solution
1. Bad ground contacts in OPC and/or developer.	1. Remove contamination of the terminals of the developer.
2. Abnormal solenoid.	2. Perform the engine self test using DCU to check if the Solenoid is normal.(refer to code 06)
	3. If not solved by the above directions 1-2, Replace the engine board.
	4. Turn the power off, delete the data of PC and try printing again.

7.2 bad discharge

7.2.1 Wrong Print Position

- **Description** Printing begins at wrong position on the paper.

Check and Cause	Solution
Wrong sense time caused by defective feed sensor actuator.	Replace the defective actuator

7.2.2 JAM 0

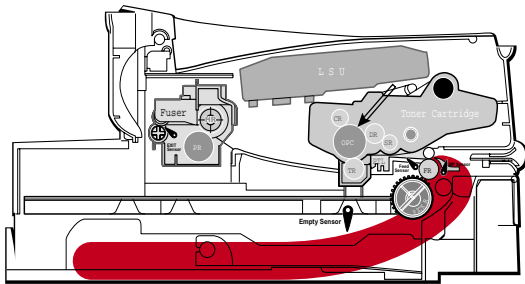

- **Description**

1. Paper is not exited from the cassette.
2. Jam-0 occurs if the paper feeds into the printer.

Check and Cause	Solution
1. Check the Solenoid by using DCU diagnostic mode 06.	1. Replace the solenoid.
2. Check if the pad is loose due to bad sealing of the side-pad.	2. Replace the side-pad Assembly L or R, if necessary.
3. Check the surface of the roller-pickup for foreign matter.	3. Clean with soft cloth dampened with IPA(Isopropyl Alcohol) or water.
4. If the paper feeds into the printer and Jam 0 occurs, perform DCU to check feed-sensor of the engine board.	4. Replace the SMPS-HVPS and/or Sensor.

7.2.3 JAM 1

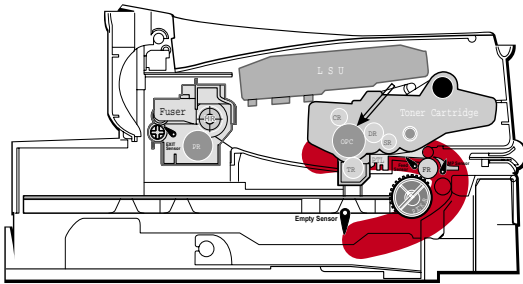

• Description

1. Recording paper is jammed in front of or inside the fuser.
2. Recording paper is stuck in the discharge roller and in the fuser just after passing through the Actuator-Feed.

Check and Cause	Solution
<ol style="list-style-type: none"> 1. If the recording paper is jammed in front of or inside the fuser. (Perform DCU diagnostic code 08) 2. If the recording paper is stuck in the discharge roller and the fuser just after passing through the Actuator-Feed, Feed Actuator may be defective. 	<ol style="list-style-type: none"> 1. Replace the SMPS. 2. Reassemble the Actuator-Feed and Spring-Actuator if the returning is bad.

7.2.4 JAM 2

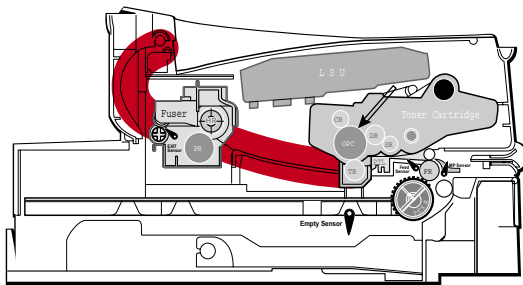

• Description

1. Recording paper is jammed in front of or inside the fuser.
2. Recording paper is stuck in the discharge roller and in the fuser just after passing through the Actuator-Feed.

Check and Cause	Solution
<ol style="list-style-type: none"> 1. If the paper is completely fed out of the printer, but Jam 2 occurs : Exit sensor is defective. <ul style="list-style-type: none"> • After the paper is completely discharged, actuator Exit should return to the original position to shut the photo-sensor. Sometimes it takes longer hour than it should and does not return. 2. If the paper is rolled in the Fuser Roller: <ul style="list-style-type: none"> • This occurs when a Guide claw is broken away or transformed. • It occurs when the Spring of a Guide claw is broken away or transformed. • It occurs when the Heat-Roller or Pressure-Roller is seriously contaminated with the toner. 3. Paper is accordion in the fuser. 	<ol style="list-style-type: none"> 1. Check if the exit sensor actuator is defective. <ul style="list-style-type: none"> • Check if the actuator exit is unformed (Check if the lever part is unformed in shape). • Check whether burrs occur in the assembly part of the actuator exit or not and if the actuator is smoothly operated. • Check if foreign matters and wire get caught in the actuator exit's operation. 2. If the paper is stuck in the fuser : disassemble the fuser and remove the jammed paper, and clean the surface of the pressure roller with dry gauze. 3. Remove the jammed paper after disassembling the fuser : Clean the surface of the pressure roller with dry gauze. <ul style="list-style-type: none"> • Remove the toner particles stained on the rib. • Check the assemblage and performance of the exit.

7.2.5 Multi-Feeding

- **Description** Multiple sheets of paper are fed at once.

Check and Cause	Solution
1. Solenoid malfunction(the solenoid does not work properly): Perform DCU Diagnostic Code 06.	1. Replace the solenoid if necessary.
2. Pad-Friction is contaminated with foreign matter.(oil...)	2. Clean the pad friction with soft clothe dampened with IPA(Isopropyl Alcohol).
3. The face of paper is blended.	3. Use the smooth paper.

7.2.6 Paper rolled in the Fuser

- **Description** If contaminated at intervals of 57mm on the back of a paper.

Check and Cause	Solution
1. Contamination of the pressure roller or heat roller (Background, Hot off set).	1. After disassembling the fuser, clean contamination between the heat roller and the thermostat and remove the contamination of the pressure roller.
2. Check the claw of the fuser whether it is unfitted.	2. If there is heavy background, repair it by the background troubleshooting method. 3. The surface of the heat roller with IPA or water 4. Check the warp or separation of the sprint claw and the holder plate claw, and then manage it.

7.2.7 Paper rolled in the Toner Cartridge (OPC Drum)

- **Description** Paper is rolled up in the OPC.

Check and Cause	Solution
<ol style="list-style-type: none">1. Paper is too much thin.2. The face of paper is curled.	<ol style="list-style-type: none">1. Recommend to use normal paper.2. How to remove the rolled in the OPC Drum.<ul style="list-style-type: none">• Remove the paper while turning the OPC Drum against the ongoing direction.• Clean fomer[romts on the OPC Drum spft;u with IPA(Isopropyl Alcohol) or tissue.

7.3 Malfunction

7.3.1 All LEDs blinking (Fuser Error)

- **Description**
1. All the lamps on the operator panel blink.
 2. Gear of the fuser does not work and breaks away melt away.
When printing, motor breaks away from its place due to defective fuser gear.

Check and Cause	Solution
1. Check if the thermostat, AC wire and Heat Lamp is open.	1. If the thermostat is open replace the fuser and check following items.
2. Check if the thermistor sensor is in place.	2. If the thermistor sensor device is located deep in the sponge, replace the fuser.
3. Check if the heat lamp works properly.	3. Check if the circuit of overheat mode works properly.
4. Check if the overheat circuit works properly.	4. Run DCU mode : Perform DCU diagnostic code 10.
5. The fuser gear is defective due to melting away.	5. Replace Fuser.

7.3.2 All LEDs blinking (Scan Error)

- **Description**
1. All lamps on the operator panel blink.

Check and Cause	Solution
DCU Mode : Perform DCU diagnostic code 05. If the DCU error code 95 is displayed, replace LSU.	Replace LSU. If you cannot solve the problem after you replace LSU, replace the main board.

7.3.3 Not function of the gear of the fuser due to melting away

- **Description** The motor breaks away from its place due to gear melting away.

Check and Cause	Solution
DCU Mode : Check if the Error States '60' '62' '68' occur. Check the operation of Fuser Erasing Lamp On/Off with the Error Code Check -10-.	<ol style="list-style-type: none"> 1. Replace the Fuser. 2. Replace the Main Control board.

7.3.4 Paper Empty

- **Description** The paper lamp on the operator panel is on even when paper is loaded in the cassette.

Check and Cause	Solution
<ol style="list-style-type: none"> 1. Bending or deformation of the actuator of the paper sensor. 2. The function of the engine board is defective Perform DCU mode : Perform DCU diagnostic code 8. 	<ol style="list-style-type: none"> 1. Replace the defective actuator. 2. Replace the engine board.

7.3.5 Paper Empty without indication

- **Description** The paper lamp on the operator panel does not come on when the paper cassette is empty.

Check and Cause	Solution
<ol style="list-style-type: none"> 1. Bending or deformation of the actuator of the paper sensor. 2. The function of the engine board is defective Perform. DCU mode : Perform DCU diagnostic code 8. 	<ol style="list-style-type: none"> 1. Replace the defective actuator. 2. Replace the engine board.

7.3.6 Cover Open

- **Description** The ERROR lamp is on even when the print cover is closed.

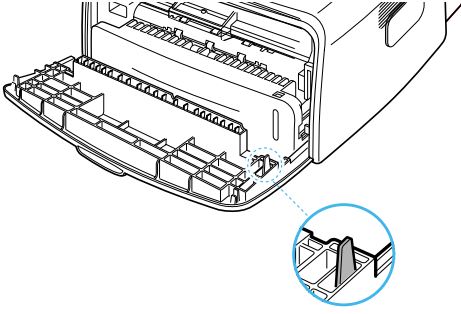
Check and Cause	Solution
<p>1. The Hook Lever in the top cover may be defective.</p> <p>2. Check the connector (Engine B'd↔HVPS) and circuit of the cover switch department in the Main Control board. Perform DCU mode : If Error state '64' occurs, Check the related codes of the Cover Open Error.</p> 	<p>1. Replace the hook lever, if defective.</p> <p>2. Check the insertion of the Cover Open S/W Connect.</p> <p>3. Replace the Main Control board or Cover Open S/W.</p>

7.3.7 No lamp on when the cover is open

- **Description** The ERROR lamp does not come on even when the printer cover is open

Check and Cause	Solution
<p>1. Check the connector(CN8) and circuit of the cover switch department in the Main Control board. Perform DCU mode : If Error state '64' occurs, Check the related codes of the Cover Open Error</p>	<p>1. Check the insertion of the Cover Open S/W Connect.</p> <p>2. Replace the Main Control board or Cover Open S/W.</p>

7.3.8 Defective motor operation

- **Description** Main motor is not driving when printing, and paper does not feed into the printer, resulting 'Jam 0'.

Check and Cause	Solution
1. Motor harness or sub PCB may be defective. 2. Perform DCU diagnostic code 00 and Check the motor operation.	1. Check the motor harness, replace it, if defective. 2. Replace the SMPS, if necessary.

7.3.9 No Power

- **Description** When system power is turned on, all lamps on the operator panel do not come on.

Check and Cause	Solution
1. Check if the power input and SMPS output are normal. 2. Check the inferiority of LED-Panel on the front-cover if the LED of Panel does not appear after normal warming-up.	1. Replace the power supply cord or SMPS. 2. Replace the control board. 3. Replace the LED-panel.

7.3.10 Vertical Line Getting Curved

- **Description** When printing, vertical line gets curved.

Check and Cause	Solution
1. If the supply of +24v is unstable in the Main Control board linking with LSU, check drive by DCU Mode : LSU Check -05- LSU Motor on.	1. Replace LSU. 2. Replace the Main Control board.

7.4 Toner Cartridge Service

It is not guaranteed for the default caused by using other toner cartridge other than the cartridge supplied by the Samsung Electronic or caused by non-licensed refill production.

7.4.1 Precautions on Safe-keeping of Toner Cartridge

Excessive exposure to direct light more than a few minutes may cause damage to the cartridge.

7.4.2 Service for the Life of Toner Cartridge

If the printed image is light due to the life of the toner, you can temporarily improve the print quality by redistributing the toner (Shake the toner cartridge), however, you should replace the toner cartridge to solve the problem thoroughly.

7.4.3 Redistributing Toner

When toner is low, faded or light areas may appear on a printed page. You may be able to temporarily improve the print quality by redistributing the toner. The following procedures may allow you to finish the current print job before replacing the toner cartridge.

- 1) Grasp the front cover and pull it toward you to open.
- 2) Remove the toner cartridge from the printer

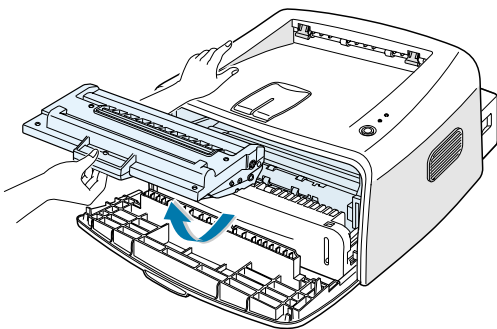

Note :

Avoid reaching too far into the printer. The fusing area may be hot.
To prevent damage to the toner cartridge, do not expose it to light for more than a few minutes.

- 3) Gently shake the toner cartridge from side to side five or six times to redistribute the toner.

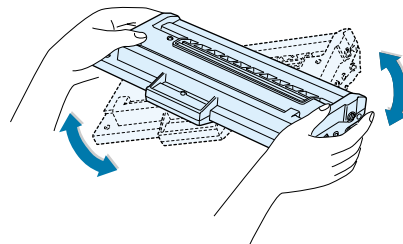

Note :

If the toner gets on your clothing, wipe it off with a dry cloth and wash clothing in cold water. Hot water sets toner into fabric.

- 4) Reinsert the toner cartridge into the printer. Ensure that the toner cartridge snaps into place.
- 5) Close the front cover. Make sure that the cover is securely closed.

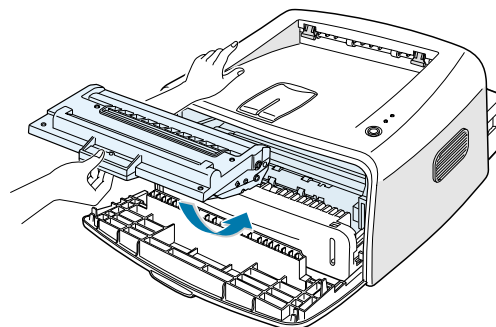

7.4.4 Signs and Measures at Poor toner cartridge

Fault	Signs	Cause & Check	Solution
<p>Light image and partially blank image (The life is ended.)</p> <div data-bbox="164 495 359 719" style="border: 1px solid black; padding: 5px; margin: 10px 0;"> Digital Printer Digital Printer Digital Printer Digital Printer Digital Printer </div>	<ul style="list-style-type: none"> • The printed image is light or unclean and untidy. • Some part of the image is not printed. • Periodically a noise as "tick tick" occurs. 	<ol style="list-style-type: none"> 1. If the image is light or unclean and untidy printed image - Shake the developer and then recheck. (1)NG : Check the weight of the developer (2)OK : Lack of toner, so the life is nearly closed. 2. Some part of image is not printed - Shake the developer and then recheck. (1)NG : Check the weight of the developer and clean the LSU window with a cotton swab, then recheck. (2)OK : Lack of toner, so the life is nearly closed. 3. Periodically a noise as "tick tick" occurs - Measure the cycle and the weight of the developer. 4. White vertical stripes on the whole screen or partly : Check the weight of the developer. 	<ol style="list-style-type: none"> 1. All of 1, 2, 3 above- If it become better by shaking, replace with a new developer after 35.3-100 sheets in the closing state of the life span. 2. In case of 2- If it becomes better after cleaning the LSU window, then the developer is normal. (Because of foreign substance on the LSU window, the image has not been printed partly.) 3. In case of 3- If the cycle of noise is about 2 seconds, the toner inside the developer has been nearly exhausted.(Purchase and replace with a new developer after using about 200 sheets at the point of occurrence) 4. In case of 3- This is a phenomenon caused by lack of toner, so replace with a new developer.
<p>Toner Contamination</p>	<ul style="list-style-type: none"> • Toner is fallen on the papers periodically. • Contaminated with toner on prints partly or over the whole surface. 	<ol style="list-style-type: none"> 1. Toner is fallen on the paper periodically. (1)Check the cycle of the falling of the toner. (2)Check the appearance of both ends of the developer OPC drum. 2.The center of the printed matter is contaminated with toner. (1)Check whether foreign substances or toner are stuck to the terminal (contact point) of the developer. (2)Check whether the state of the terminal assembly is normal. 	<ol style="list-style-type: none"> 1. If both ends of the OPC drum are contaminated with toner: Check the life of the developer. 2. Check whether it could be recycled. 3. If it cannot be recycled: Replace the developer.

Fault	Signs	Cause & Check	Solution
<p>White Black spot</p> 	<ul style="list-style-type: none"> • Light or dark black dots on the image occur periodically. • White spots occur in the image periodically. 	<ol style="list-style-type: none"> 1. If light or dark periodical black dots occur, this is because the developer rollers are contaminated with foreign substance or paper particles. <ol style="list-style-type: none"> (1)37.7mm interval : Charged roller (2)75.5mm interval : OPC cycle 2. If white spots occur in a black image at intervals of 75.5mm, or black spots occur elsewhere, the OPC drum is damaged or foreign substance is stuck to the surface. 3. If a black and white or graphic image is partially broken at irregular intervals, the transfer roller's life has been expired or the transfer voltage is abnormal. 	<ol style="list-style-type: none"> 1. In case of 1 above - Run OPC Cleaning Mode Print 4-5 times repeatedly to remove. Especially check foreign substance on the OPC surface, then remove them with a clean gauze moistened with IPA(Isopropyl Alcohol) not to damage OPC if necessary. <ul style="list-style-type: none"> ▲ Never use usual alcohol. 2. In case of 2 <ul style="list-style-type: none"> If they are not disappeared by running OPC Cleaning Mode Print 4-5 times. : at intervals of 37.7mm - Replace the developer. : at intervals of 75.5mm - Remove foreign substance. : Broken image - Replace the developer according to carelessness. 3. In case of 3 - Exchange the transfer roller because the life of the transfer roller in use has been expired. (Check the transfer voltage and readjust if different.)
<p>Recycled product</p>	<ul style="list-style-type: none"> • Poor appearance of the developer. • Unclean and rough printouts. • Bad background in the image. 	<ol style="list-style-type: none"> 1. Poor appearance of the developer. <ol style="list-style-type: none"> (1)Check the damage to label and whether different materials are used. (2)Check the appearance of parts of the developer, such as frame, hopper. 2. Unclean and rough printouts. <ol style="list-style-type: none"> (1)Check whether foreign substance or toner are stuck to the terminal (contact point) of the developer. (2)Check whether the state of the terminal assembly is normal. 	<ol style="list-style-type: none"> 1. In case of 1 - <ol style="list-style-type: none"> (1)If there is an evidence of disassembling the developer. (2)If materials other than normal parts of the developer are added or substituted. 2. In case of 2 - If there are any abnormal in connection with the situation of 1. <ol style="list-style-type: none"> (1)It occurs when the developer is recycled over 2 times. (2)If toner nearly being expired are collected to use, it is judged as the recycled developer.

7.5 Bad Environment of The Software

7.5.1 The printer is not working (1)

- **Description** While Power turned on, the printer is not working in the printing mode.

Check and Cause	Solution
1. Run Self-Test Mode : Turn the power on while pressing the test printing button for 2 or 3 seconds before printing works.	1. Check the power of the printer and perform the Self-Test. If the test printing works, that means no problems in the printer itself. If the test printing does not work, that means bad functioning of the printer (not because of software). Perform DCU to check the Error Status.
2. Check if the PC and the printer is properly connected and the toner cartridge installed.	2. Replace the printer cable. If the problems not solved even after the cable replaced, check the amount of the remaining tone. (refer to Toner Cartridge Service 7.4)
3. Printing is nor working in the Windows.	3. Check if the connection between PC and printer port is proper. If you use windows, check if the printer driver in the controller is set up. If the printer driver is properly set up, check in which program the printing is not working. The best way to find out is to open the memo pad to check the function of printing. If it is not working in a certain program, adjust the setup the program requires. Sometimes, the printout is normal within the Windows basic programs, but it's not working in a particular program. In such case, install the new driver again. If not working in the Windows basic program, Check the setup of the port of CMOS is on ECP. And check the address of IRQ 7 and 378
4. Check if the printer cable is directly connected to peripheral devices	4. If the scanner needs to be connected to the printer, first the remove the scanner from the PC to see if the printer is properly working alone.

7.5.2 The printer is not working (2)

- **Description** After receiving the printing order, no response at all or the low speed of printing occurs due to wrong setup of the environment rather than malfunction of the printer itself.

Check and Cause	Solution
1. Secure more space of the hard disk.	1. Not working with the message 'insufficient printer memory' means hard disk space problem rather than the RAM problem. In this case, provide more space for the hard disk. Secure more space using the disk utilities program.
2. Printing error occurs even if there is enough space in the hard disk.	2. The connection of the cable and printer port is not proper. Check if the connection is properly done and if the parallel port in CMOS is rightly set up.
3. Check the parallel-port-related items in the CMOS Setup.	3. As a printer port, Select ECP or SPP among SPP(Normal), ECP, and EPP modes(increase printing speed) SPP normal mode support 8-bit data transfer, while ECP Mode transfer the 12-bit data.
4. Reboot the system to print.	4. If the regular font is not printing, the cable or the printer driver may be defective. Turn the PC and printer off, and reboot the system to print again. If not solved, double-click the printer in my computer. If the regular fonts are not printed this time again, the cable must be defective so replace the cable with new one.

7.5.3 Abnormal Printing

• **Description**

The printing is not working properly even when the cable has no problem.
(even after the cable is replaced)

If the printer won't work at all or the strange fonts are repeated, the printer driver may be defective or wrong setup in the CMOS Setup.

Check and Cause	Solution
1. Set up the parallel port in the CMOS SETUP.	1. Select SPP(Normal) or ECP LPT Port the among ECP, EPP or SPP in the CMOS Setup.
2. Printer Driver Error.	2. Check the printer in My Computer.(to see if the printer driver is compatible to the present driver or delete the old driver, if defective and reinstall the new driver)
3. Error message from insufficient memory. (The printing job sometimes stops or due to insufficient virtual memory, but it actually comes from the insufficient space of the hard disk.)	3. Delete the unnecessary files to secure enough space of the hard disk and start printing job again.

7.5.4 SPOOL Error

• Description

To spool which stands for "simultaneous peripheral operations online" a computer document or task list (or "job") is to read it in and store it, usually on a hard disk or larger storage medium so that it can be printed or otherwise processed at a more convenient time (for example, when a printer is finished printing its current document).

Check and Cause	Solution
1. Insufficient space of the hard disk in the directory assigned for the basic spool.	1. Delete the unnecessary files to provide more space to start printing job.
2. If the previous printing error not solved.	2. If there are some files with the extension name of ****.jnl, Delete them and Reboot the Windows to restart printing job.
3. When expected to collide with other program.	3. Shut down all other programs except the current one, if possible.
4. When an application program or the printer driver is damaged.	4. Delete the printer driver completely and reinstall it.
5. When some files related to OS are damaged or virus infected.	5. After rebooting the computer, check for viruses, restore the damaged files and reinstall the program to do the printing job.
6. Memory is less than suggested one.	6. Add up enough memory to the PC.

How to delete the data in the spool manager.

In the spool manager, the installed drivers and the list of the documents waiting to be printed are shown. Select the document to be deleted and check the delete menu.

If you intend to delete the current document being printed, the data being transferred to the printer will be put out and then the document is removed. Before choosing the document, the menu is still inactive.

Or put the document out of the list and repeat the routine as in the above or finish the spool manager.

8. Exploded Views and Parts List

5-1. Main Assembly	page(5-2)
5-2. Frame Unit Assembly	page(5-4)
5-3. Drive Unit Assembly	page(5-7)
5-4. Fuser Unit Assembly	page(5-8)
5-5. Cassette Unit Assembly	page(5-10)

- Deal drawings and service parts are declared for the items with higher rate of inferiority and replaceable in the level of service description only.
- If inferiority occurs, you can replace the parts by the unit declared in deal drawings and service items.

Way to observe Part Code & Description

Part code and Description is quoted and controlled by determined standard. Refer to this determined standard, it will help with ordering Part.

- There are two kinds of Part code inscription type.

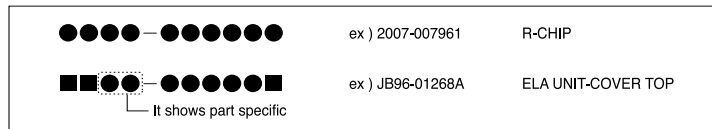

(● : figure, ■ : character (alphabet))

Type 1 : Controlled by Company : It can be commonly used for all kinds of product SEC produce. Mostly, electronics Parts.

Type 2 : Controlled by Division : It is used or one produce. Mostly, Mostly, mechanical Parts.

- **A/S privately used part** : It is only used for A/S .
- **Ass'y part** : Assembled by more than 2 Parts. If necessary part is not A/S Part, Ass'y part including necessary par can be used. It is shown in the diagram and drawing of SVC manual.
- Ass'y part and A/S privately used Part is distinguished by part Code and Description. The are inscription type 2. It is recognized by Part character and front side of description.

DIVISION	PART CODE	DESCRIPTION
A/S Private	**81_***** (JB81-00039A)	AS-***** (AS-USE)
ASS'Y Part	**75_***** (JB75-00068A)	MEC-***** (MEC-CHUTE)
ASS'Y Part	**92_***** (JB92-01131A)	PBA ***** (PBA MAIN-CONTROLLER)
ASS'Y Part	**97_***** (JB97-01089A)	MEA ***** (MEA UNIT-PULLEY IDLE)

8.1 Main Assembly

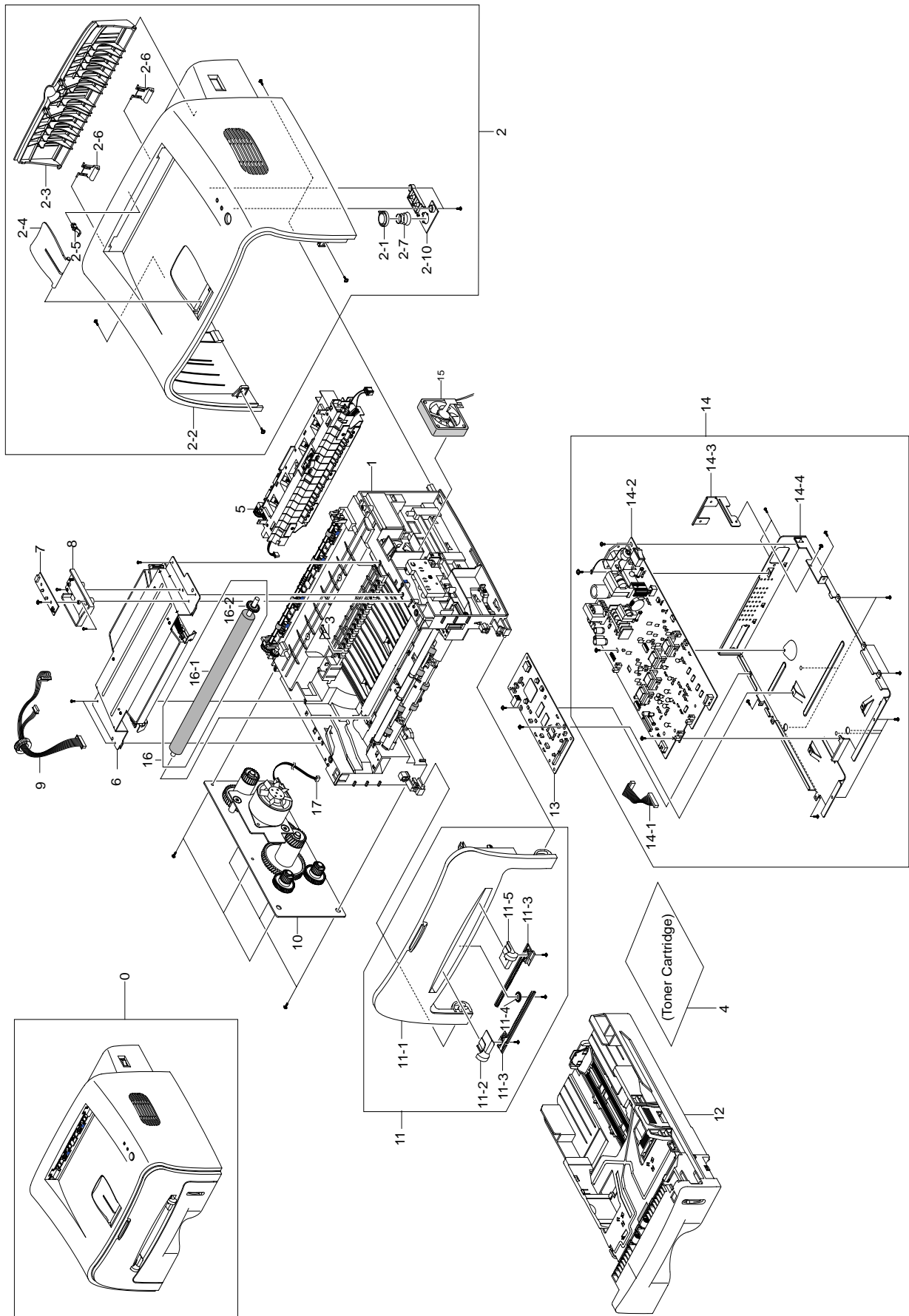

Main Assembly Parts List

SA : Service Available

O : Service available X : Service not available

No.	Description	SEC.Code	Q'ty	SA	Remark
0	SET				
1	ELA UNIT-FRAME ASSY 110V	JC96-02732A	1	@	
2	ELA HOU-COVER TOP	JC97-01748A	1	@	
2-1	LENS LED-LED	JC67-00026A	1	@	
2-2	COVER-TOP	JC63-00102A	1	@	
2-3	COVER-REAR	JC63-00101A	1	@	
2-4	PMO-STACKER_RX	JC72-00973A	1	@	
2-5	PMO-BUSHING_F/DOWN	JC72-00387A	1	@	
2-6	PMO-SUB STACKER	JC72-01001A	1	@	
2-7	SPRING-KEY	6107-001169	1	@	
2-8	KEY-ON LINE	JC64-00039A	1	@	
2-9	SCREW-TIPTITE	6003-000264	2		
3	PLATE-CHANNEL	JC61-00606A	1	@	
4	MEA UNIT-TONER CARTRIDGE 1710	JC97-01744A	1	@	
5	ELA HOU-FUSER 220V	JC96-02660A	1	@	
6	UNIT-LSU	JC59-00018A	1	@	
7	PBA SUB-LED PANEL	JC92-01439A	1	@	
8	COVER PCB-PCB	JC63-00104A	1	@	
9	CBF HARNESS-LSU 1400	JC39-00242A	1	@	
10	ELA HOU-RX DRIVE 1400	JC96-02733A	1	@	
11	MEA ETC-COVER FRONT	JC97-01746A	1	@	
11-1	COVER-FRONT	JC63-00103A	1	@	
11-2	ADJUST-MANUAL L	JC70-00302A	1	@	
11-3	ADJUST RACK-MANUAL	JC70-00304A	1	@	
11-4	GEAR-RACK_PINION	JC66-00387A	1	@	
11-5	ADJUST-MANUAL R	JC70-00303A	1	@	
11-6	SCREW-TIPTITE	6003-000264	3		
12	MEA ETC-CASSETTE 1400	JC97-01750A	1	@	
13	PBA-CONTROLLER SPL	TBD	1	@	
14	MEA ETC-SHIELD ENGINE	JC96-02663A	1	@	
14-1	CBF HARNESS-MAIN_SMPS	JC39-00240A	1	@	
14-2	SMPS-HVPS HPHR(110V)	JC44-00045A	1	@	110V
14-3	BRACKET-INLET	JC61-00601A	1	@	
14-4	SHIELD-ENGINE	JC63-00107A	1	@	
14-5	SCREW-TIPTITE	6003-000264	6		
14-6	SCREW-TIPTITE	6003-000119	2		
14-7	SCREW-TIPTITE	6003-000301	1		
15	FAN-DC	JC31-00027A	1	@	
16					
16-1	ROLLER-TRANSFER ROLLER	JC66-00528A	1	@	
16-2	GEAR-TRANSFER	JC66-00395A	1	@	
17	CBF HARNESS-MOTOR	JC39-00241A	1	@	

8.2 Frame Unit Assembly

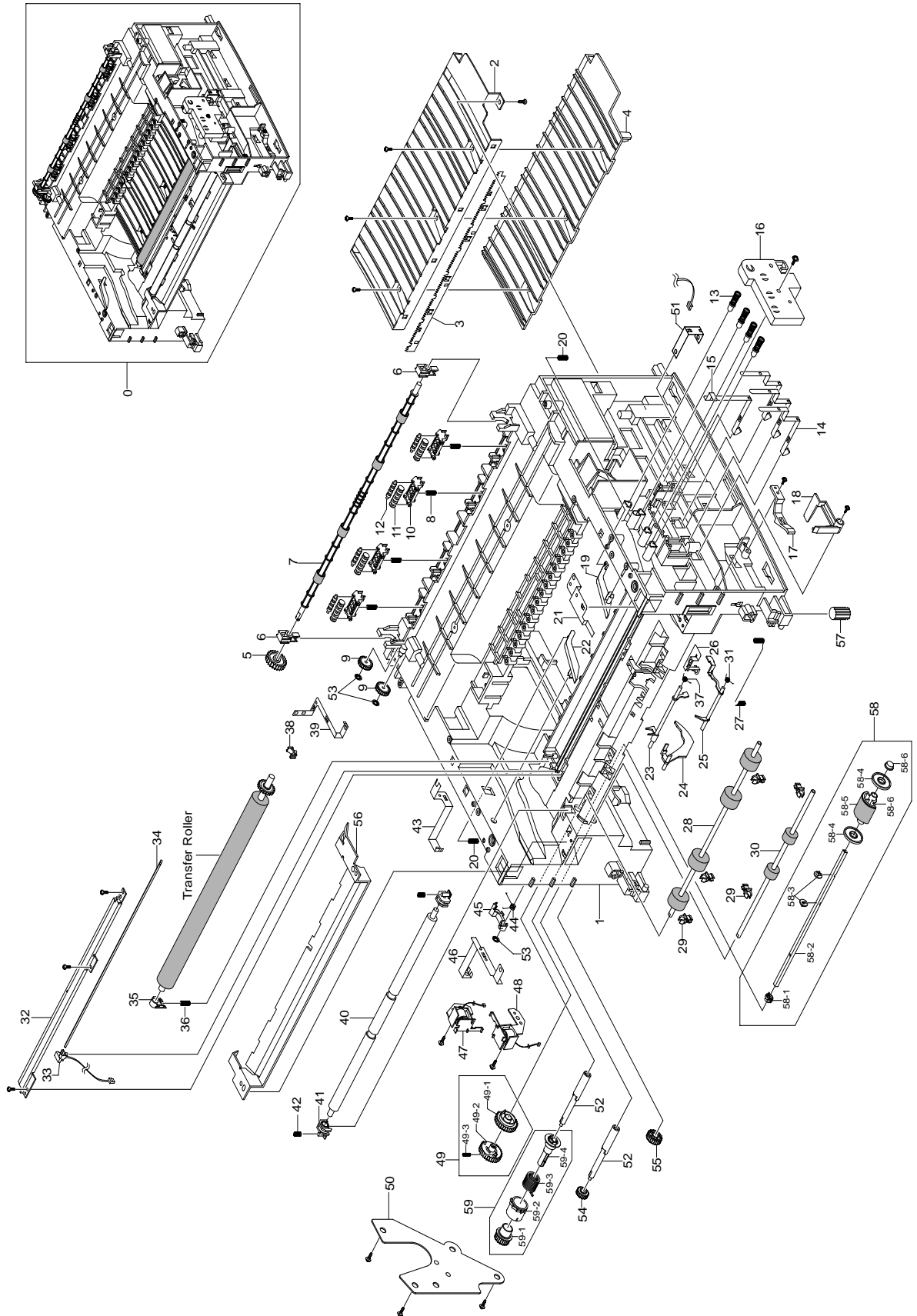

Frame Unit Assembly Parts List

SA : Service Available

O : Service available X : Service not available

No.	Description	SEC.Code	Q'ty	SA	Remark
0	ELA UNIT-FRAME ASSY 110V	JC96-02732A	1	@	
1	FRAME-Base	JC61-00579A	1	@	
2	GUIDE-TR	JC61-00607A	1	@	
3	PLATE-SAW	JC61-00604A	1	@	
4	GUIDE-TR RIB	JC61-00594A	1	@	
5	GEAR-EXIT F/DOWN	JC66-00038A	1	@	
6	MEC-BEARING,EXIT	JC75-10529A	2	@	
7	ROLLER-EXIT_F/DOWN	JC66-00378A	1	@	
8	SPRING-EXIT_F/DOWN	6107-001163	1	@	
9	PMO-GEAR_EXIT_DRV16	JC72-00143A	2	@	
10	HOLDER-EXIT_F/DOWN	JC61-00582A	4	@	
11	PMO-ROLLER_EXIT,MAIN	JC72-41081A	4	@	
12	PMO-ROLLER_EXIT,FR	JC72-41082A	4	@	
13	MEC-TERMINAL	JC75-00049A	4	@	
14	IPR-TERMINAL CON	JC70-00312A	3	@	
15	IPR-TERMINAL CR	JC70-00313A	1	@	
16	HOUSING-TERMINAL	JC61-00592A	1	@	
17	PMO-Locker cst	JC72-00983A	1	@	
18	PMO-ACTUATOR CVR OPEN	JC72-00974A	1	@	
19	PMO-PLATE GUIDE DEVE_R	JC72-00985A	1	@	
20	SPRING-GUIDE DEVE	JC61-00038A	2	@	
21	IPR-GROUND_ROLLER IDLE	JC70-00315A	1	@	
22	PMO-PLATE GUIDE DEVE_L	JC72-00984A	1	@	
23	PMO-ACTUATOR FEED	JC72-00976A	1	@	
24	PMO-ACTUATOR EMPTY	JC72-00975A	1	@	
25	PMO-ACTUATOR MANUAL	JC72-00977A	1	@	
26	IPR-GROUND EARTH TR	JC70-00309A	1	@	
27	SPRING-TR_R	6107-001162	1	@	
28	ROLLER-FEED ROLLER1	JC66-00526A	1	@	
29	PMO-BUSHING TX	JC72-00382A	5	@	
30	ROLLER-FEED	JC61-00347A	1	@	
31	SPRING-ACT,MANUAL	6107-001165	1	@	
32	IPR-EARTH TRANSFER	JC70-00307A	1	@	
33	HOLDER-PTL	JC61-00583A	1	@	
34	LENS-PTL	JC67-00027A	1	@	
35	BUSH-TR_L	JC61-00588A	1	@	
36	SPRING-TR_L	JC61-00047A	1	@	
37	SPRING-ACT_FEED	6107-001164	1	@	
38	PMO-BUSHING TR_L	JC72-00102A	1	@	
39	IPR-GROUND FUSER	JC70-00310A	1	@	
40	SHAFT-FEED IDLE	JC66-00527A	1	@	
41	BUSH-FEED IDLE	JC61-00585A	1	@	
42	SPRING-FEED IDLE	JC61-70958A	1	@	
43	IPR-P_GROUND_DRIVE2	JC70-00335A	1	@	
44	SPRING-CAM PICK-UP	6107-001170	1	@	
45	CAM-PICK_UP	JC66-00377A	1	@	
46	IPR-GROUND DRIVE	JC70-00308A	1	@	
47	SOLENOID-HB (PICK-UP)	JC33-00009A	1	@	
48	SOLENOID-HB (MANUAL)	JC33-00010A	1	@	

Frame Unit Assembly Parts List(Cont.)

SA : Service Available

O : Service available X : Service not available

No.	Description	SEC.Code	Q'ty	SA	Remark
49			1	@	
49-1	PMO-GEAR PICK_UP B	JC72-00980A	1	@	
49-2	PMO-GEAR PICK_UP A	JC72-00979A	1	@	
49-3	SPRING-PICK_UP GEAR	6107-001167	1	@	
50	BRACKET-FEED	JC61-00602A	1	@	
51	IPR-GROUND TR	JC70-00311A	1	@	
52	SHAPT-FEED	JC66-00398A	1	@	
53	RING-CS	6044-000001	3	@	
54	GEAR-FEED 2	JC66-00394A	1	@	
55	GEAR-IDLE 23	JC66-00396A	1	@	
56	GUIDE-PAPER	JC61-00718A	1	@	
57	RMO-RUBBER FOOT	JC73-00027A	2	@	
58			1	@	
58-1	BUSH-PICK_UP_L	JC61-00586A	1	@	
58-2	SHAFT-PICK_UP	JC66-00399A	1	@	
58-3	STOPPER-PICK_UP	JC61-00593A	2	@	
58-4	PMO-IDLE PICK_UP	JC72-00982A	2	@	
58-5	SPONGE-ROILLER PICK UP	JC72-01231A	1	@	
58-6	BUSH-PICK_UP_R	JC61-00587A	1	@	
58-7	HOUSING-PICK_UP	JC61-00591A	1	@	
59					
59-1	GEAR-FEED 1	JC66-00393A	1	@	
59-2	PMO-COLLAR_SPRING	JC72-00978A	1	@	
59-3	SPRING-CLUTCH	6107-001164	1	@	
59-4	PMO-HUB CLUTCH	JC72-00981A	1	@	

8.3 Drive Unit Assembly

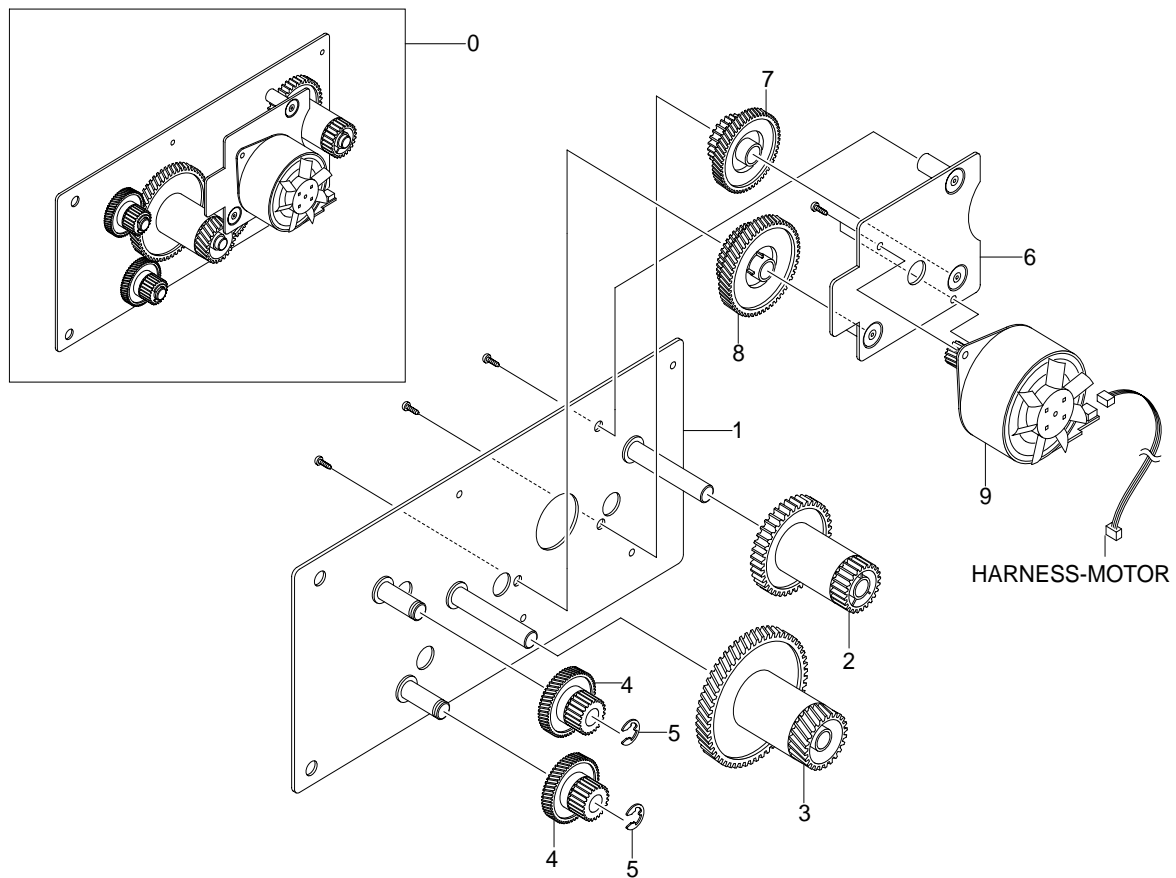

Drive Unit Assembly Parts List

SA : Service Available

O : Service available X : Service not available

No.	Description	SEC.Code	Q'ty	SA	Remark
0	ELA HOU-RX DRIVE 1400	JC96-02733A	1	@	
1	BRACKET-GEAR 1400	JC61-00598A	1	@	
2	GEAR-FUSER DRV	JC66-00388A	1	@	
3	GEAR-RDCN Z132/19	JC66-00391A	1	@	
4	GEAR-PICK_UP DRV	JC66-00389A	2	@	
5	RING-E	6044-000231	2	@	
6	BRACKET-MOTOR 1400	JC61-00599A	1	@	
7	GEAR-RDCN Z7128	JC66-00390A	1	@	
8	GEAR-RDCN Z7322	JC66-00392A	1	@	
9	MOTOR STEP-7.5	JC31-00028A	1	@	

8.4 Fuser Unit Assembly

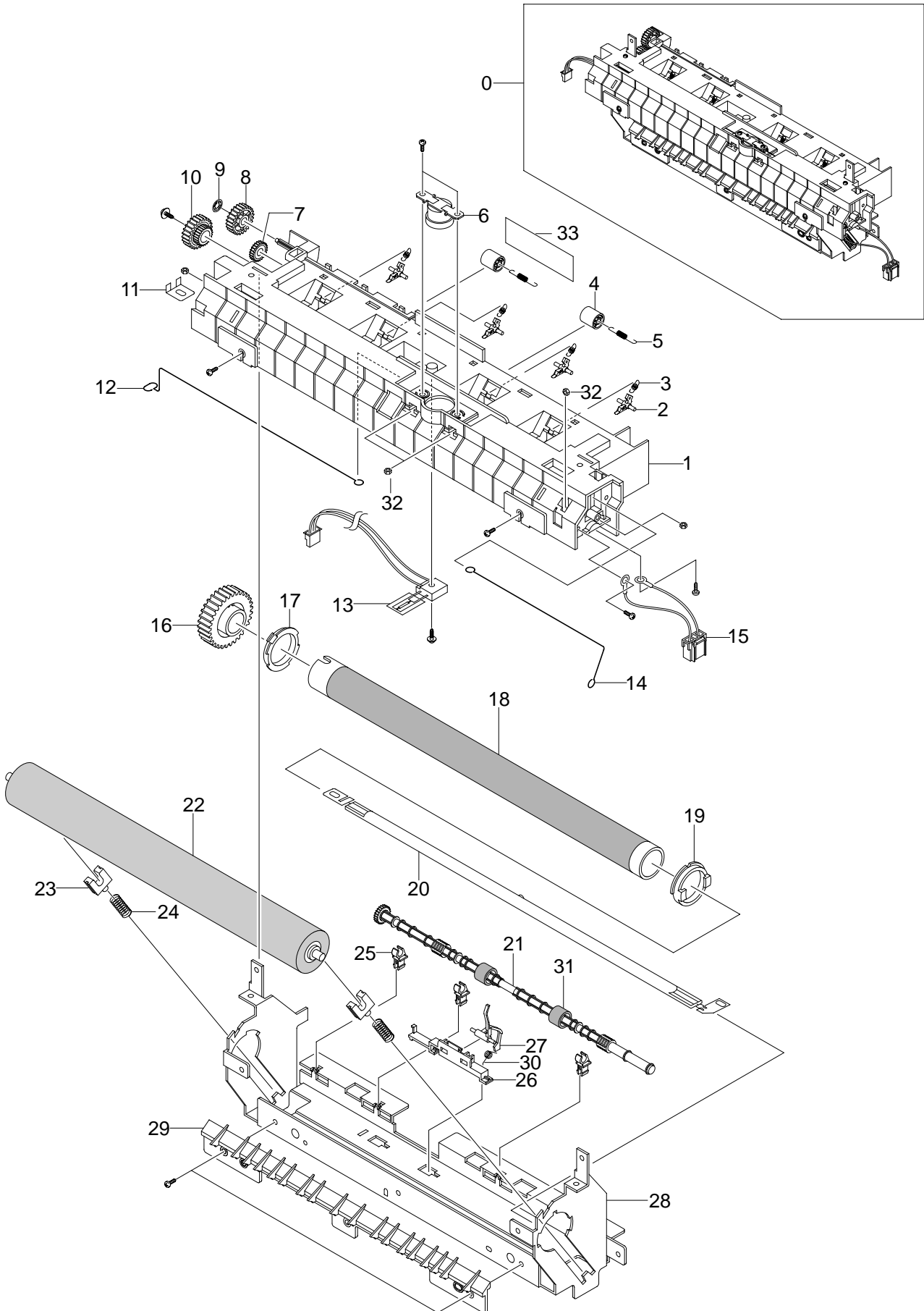

Fuser Unit Assembly Parts List

SA : Service Available

O : Service available X : Service not available

No.	Description	SEC.Code	Q'ty	SA	Remark
0	ELA HOU-FUSER 110V	JC96-	1		
1	COVER-FUSER	JC63-00105A	1		
2	HOLDER-PLATE CLAW	JC61-00584A	4		
3	SPRING ETC-CLAW	JC61-00064A	4		
4	PMO-ROLLER EXIT	JC72-60059A	2		
5	SPRING-EXIT F_UP	JC61-70976A	2		
6	THERMOSTAT-150	JC47-00005A			
7	PMO-GEAR_EXIT_DRV16	JC72-00143A	1		
8	GEAR-IDLE 23	JC66-00396A	1		
9	RING-CS	6044-000001	1		
10	GEAR-RDCN 2515	JC66-00397A	1		
11	IPR-ELECTRODE_LAMP	JC70-00275A	1		
12	ELECTRODE-WIRE_L	JC70-00450A	1		
13	THERMISTER-NTC HF	1404-001298	1		
14	ELECTRODE-WIRE_R	JC70-00449A	1		
15	CBF HARNESS-FUSER(1)	JC39-00239A	1		
16	GEAR-FUSER_HTN	JC66-00564A	1		
17	BUSH-HR_L	JC61-00589A	1		
18	NPR-ROLLER_HEAT	JC66-00601A	1		
19	BUSH-HR_R	JC61-00590A	1		
20	LAMP-HALOGEN(110V)	4713-001155	1	110V	
21	ROLLER-EXIT F_UP	JC66-00380A	1		
22	MEC-ROLLER_PR(1400)	JC66-00600A	1		
23	BEARING-PRESSURE	JC66-10901A	2		
24	SPRING-PR(1400)	6107-001168	2		
25	PMO-BUSHING TX	JC72-00382A	3		
26	HOLDER-ACTUATOR	JC61-00581A	1		
27	PMO-ACTUATOR_EXIT	JC72-00987A	1		
28	IPR-FRAME_FUSER	JC70-00317A	1		
29	GUIDE-INPUT	JC61-00595A	1		
31	RMO-RUBBER_EXIT	JC73-00017A	2		
33	"LABEL(P)-CAUTION, HOT_FUSER"	JC68-30928D	1		
30	SPRING ETC-ACT_EXIT	6107-001165	1		
32	NUT-HEXAGON	6021-000222	5		
??	NEW-CLAW ASSY	TBD			
??	PLATE-CLAW	JC61-00605A	4		

8.5 Cassette Unit Assembly

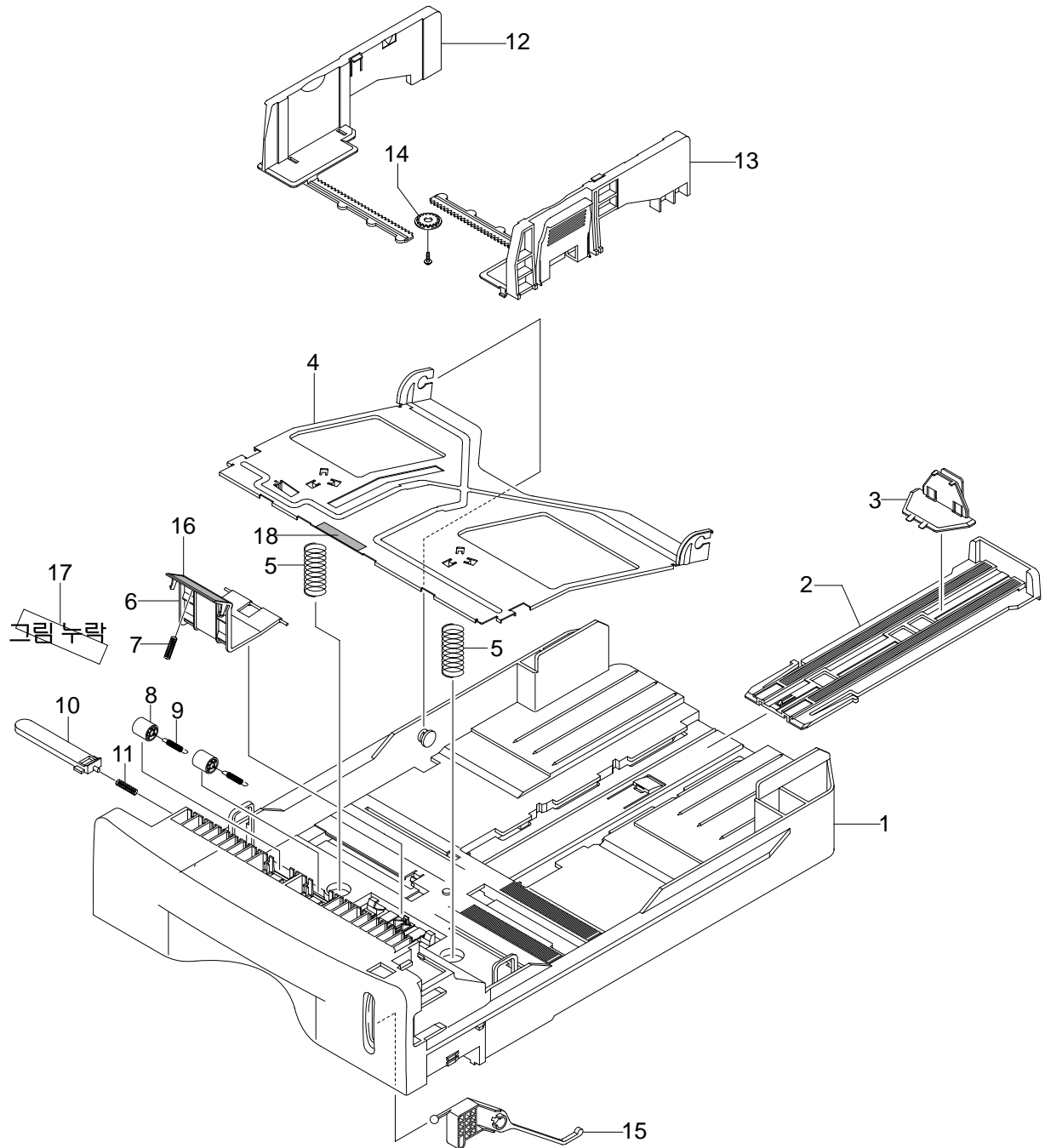
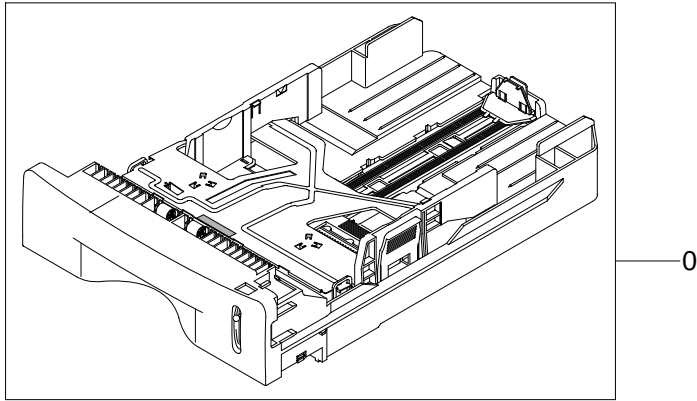

Cassette Unit Assembly Parts List

SA : Service Available

O : Service available X : Service not available

No.	Description	SEC.Code	Q'ty	SA	Remark
0	CASSETTE	TBD	1		
1	FRAME-CASSETTE	JC61-00578A	1	@	
2	PMO-EXTENSION LARGE	JC72-00970A	1	@	
3	PMO-EXTENSION SMALL	JC72-00971A	1	@	
4	PLATE-KNOCK_UP	JC61-00603A	1	@	
5	SPRING-KNOCK_UP	6107-001166	2	@	
6	HOLDER-PAD	JC61-00580A	1	@	
7	SPRING-FRICTION PAD	JC61-70911A	1	@	
8	ROLLER-IDLE FEED	JC66-00529A	2	@	
9	SPRING-FEED	6107-001047	2	@	
10	PMO-PLATE_LOCKER	JC72-00972A	1	@	
11	SPRING-LOCKER	JG61-70531A	1	@	
12	ADJUST-CASSETTE_L	JC70-00300A	1	@	
13	ADJUST-CASSETTE_R	JC70-00301A	1	@	
14	GEAR-PINION	JG66-40003A	1	@	
15	INDICATOR-LEVER INDICATOR	JC64-00040A	1	@	
16	RPR-FRICTION PAD	JC73-00140A	1	@	
17	IPR-PLATE PAD	JC70-00314A	1	@	
18	RPR-PAD CASSETTE	JC73-00141A	3	@	

9. Block Diagram

9.1 PCL Model

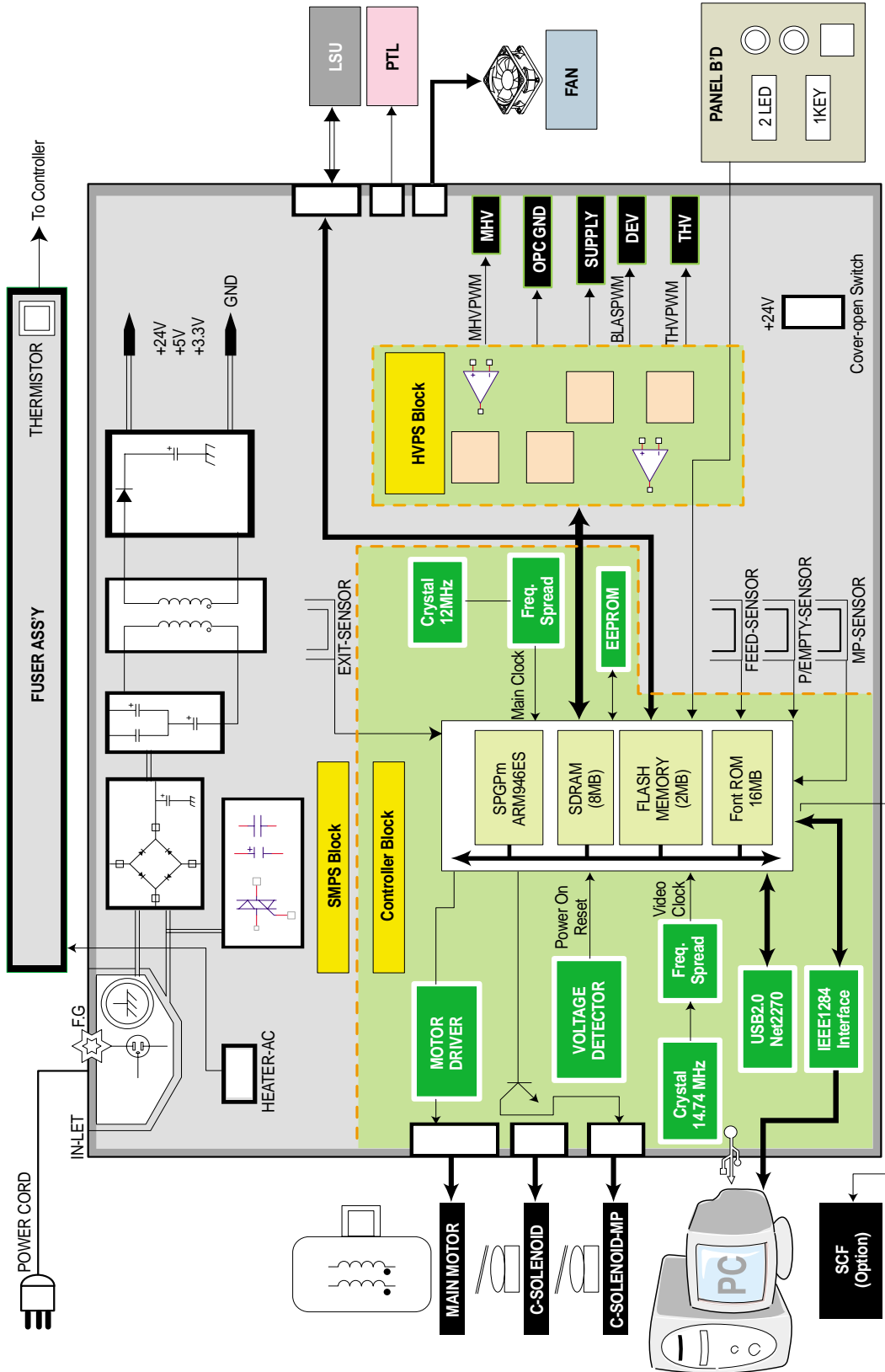

9.2 SPL Model

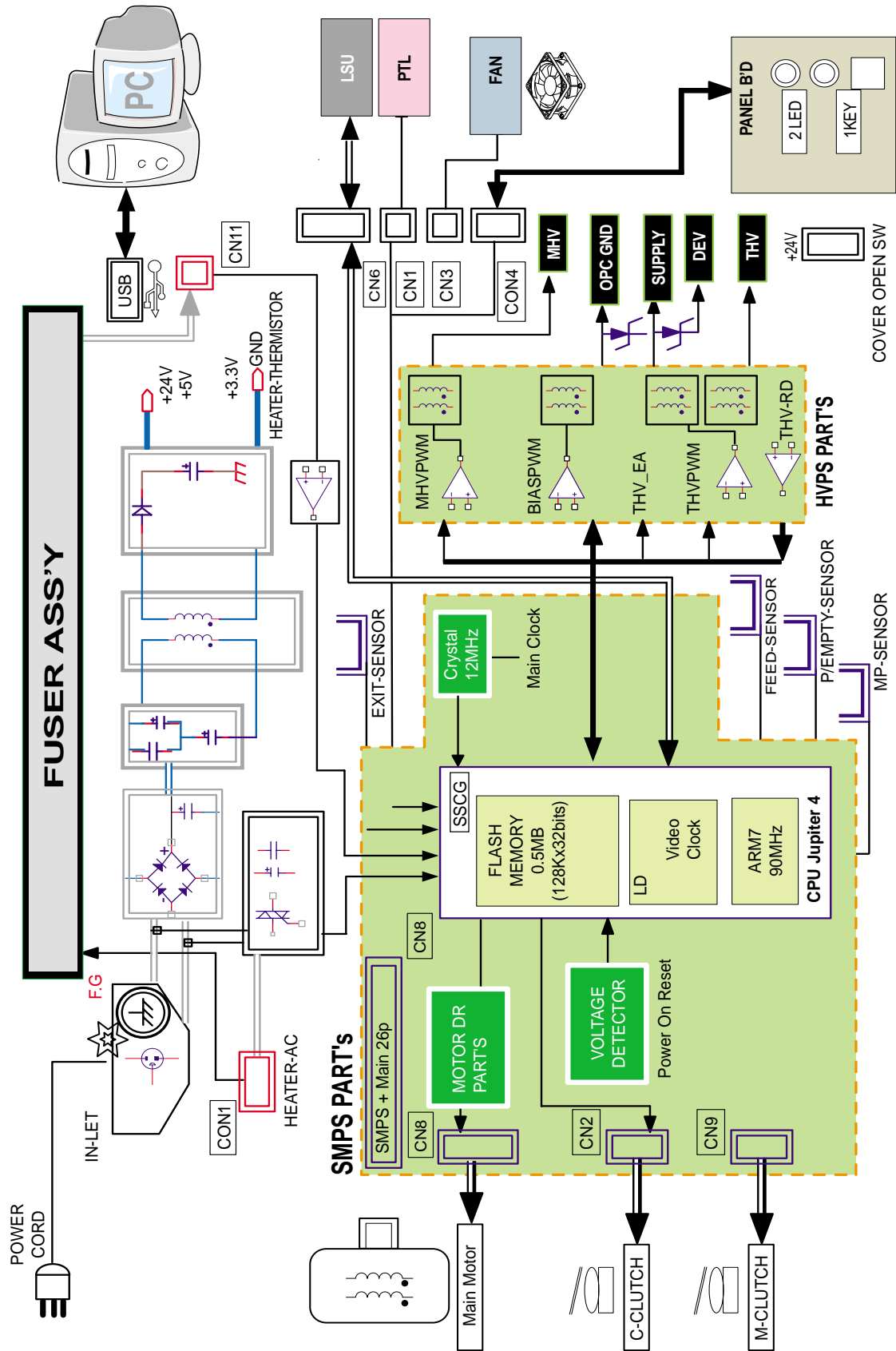

10. Connection Diagram

10.1 PCL Model

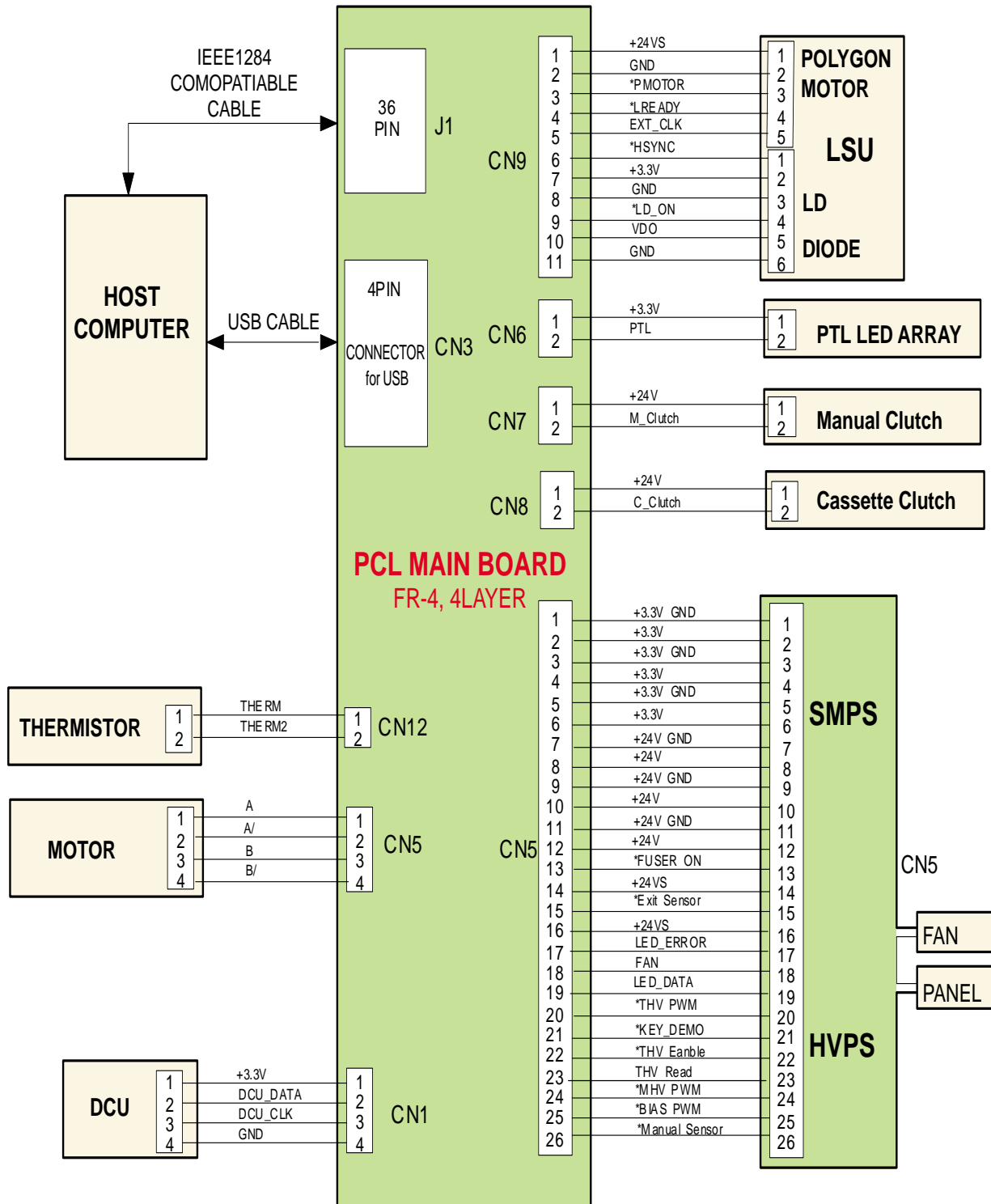

10.2 SPL Model

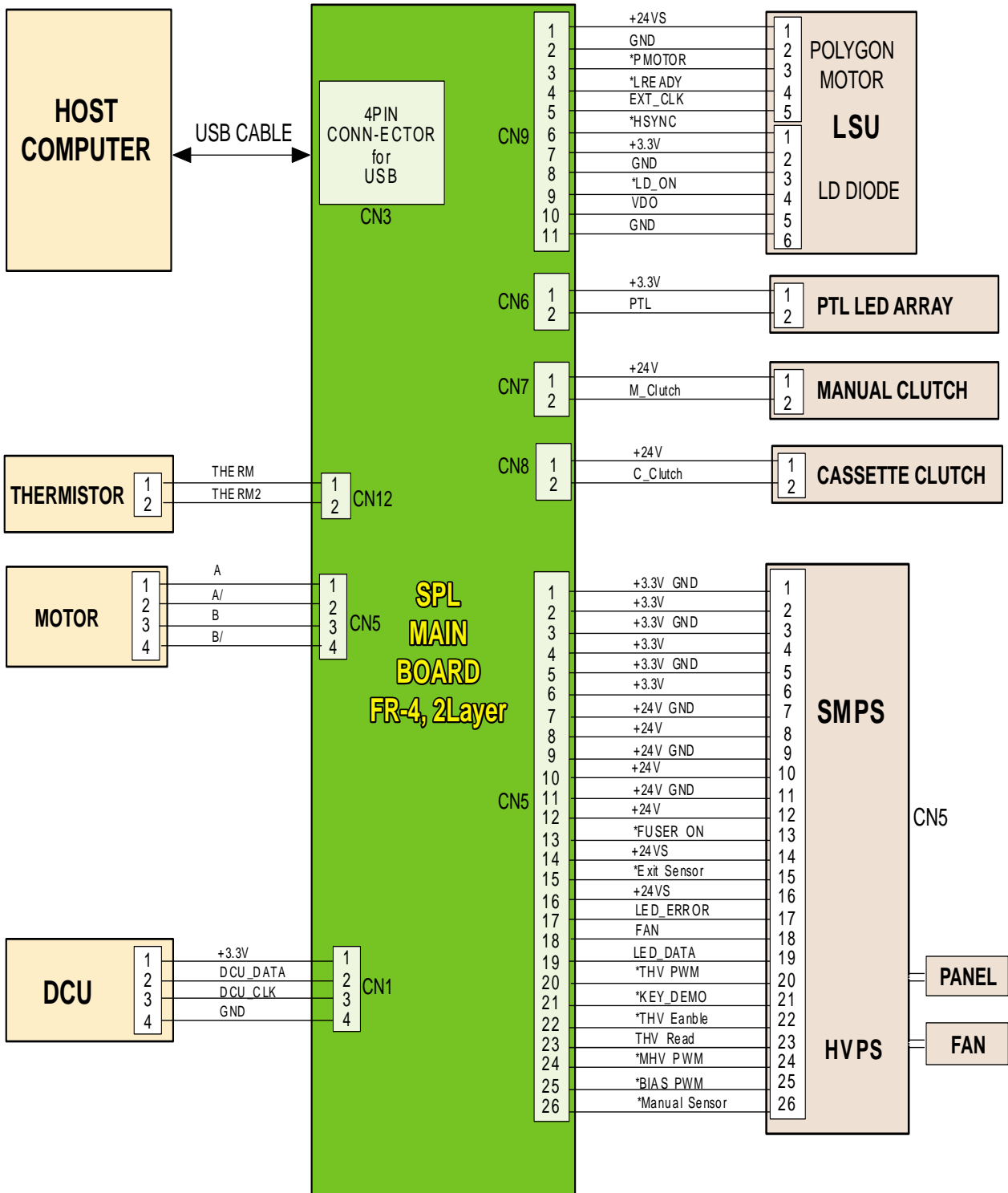

11. Schematic Diagrams

11.1 PCL Main Circuit Diagram (1/7)

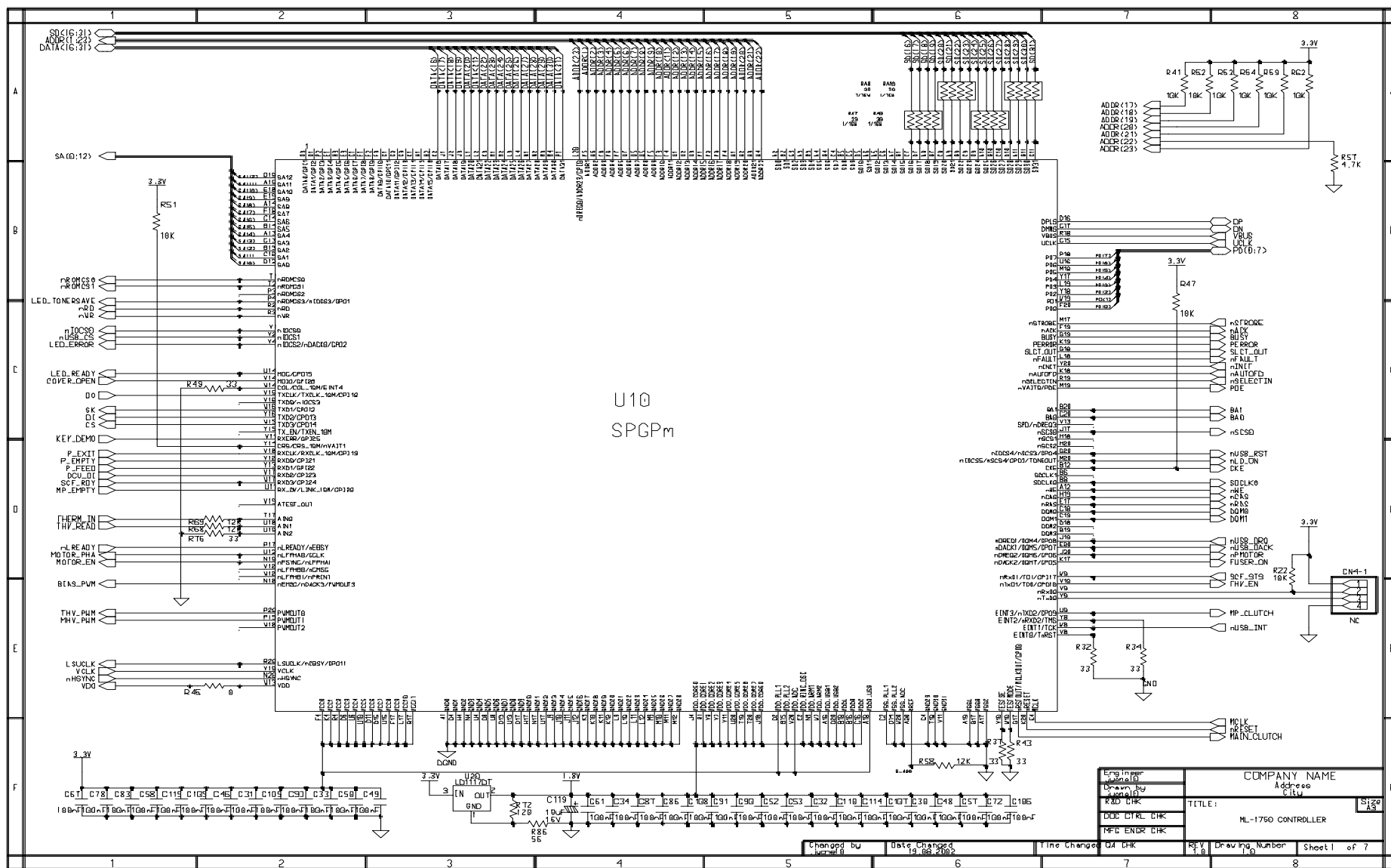

Eng. In-charge	COMPANY NAME
Drawn by	Address
Checked	City
DATE: 01.01.01	TITLE:
DATE: 01.01.01	ML-1750 CONTROLLER
DATE: 01.01.01	Sheet 1 of 7

PCL Main Circuit Diagram (3/7)

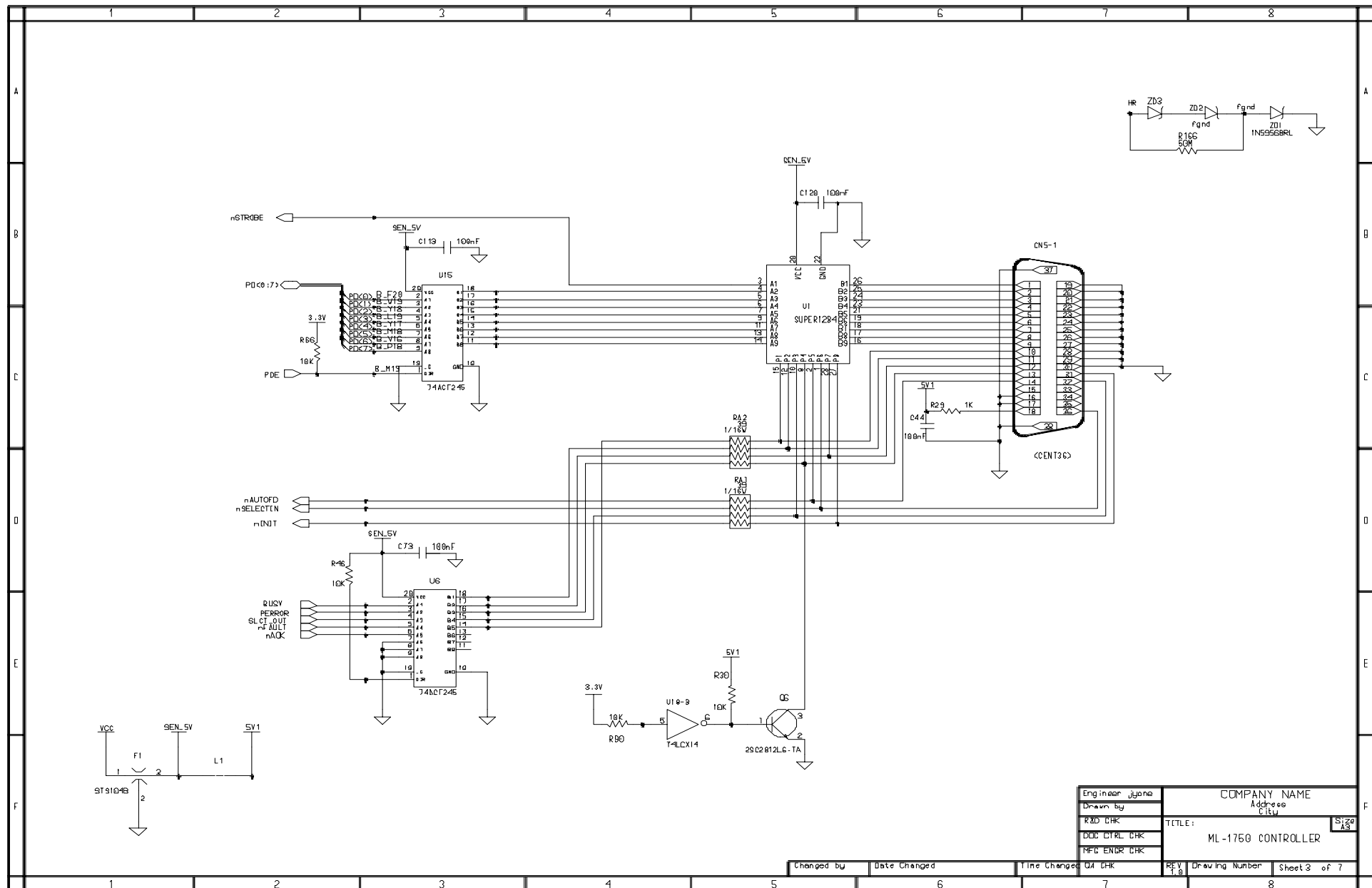

PCL Main Circuit Diagram (4/7)

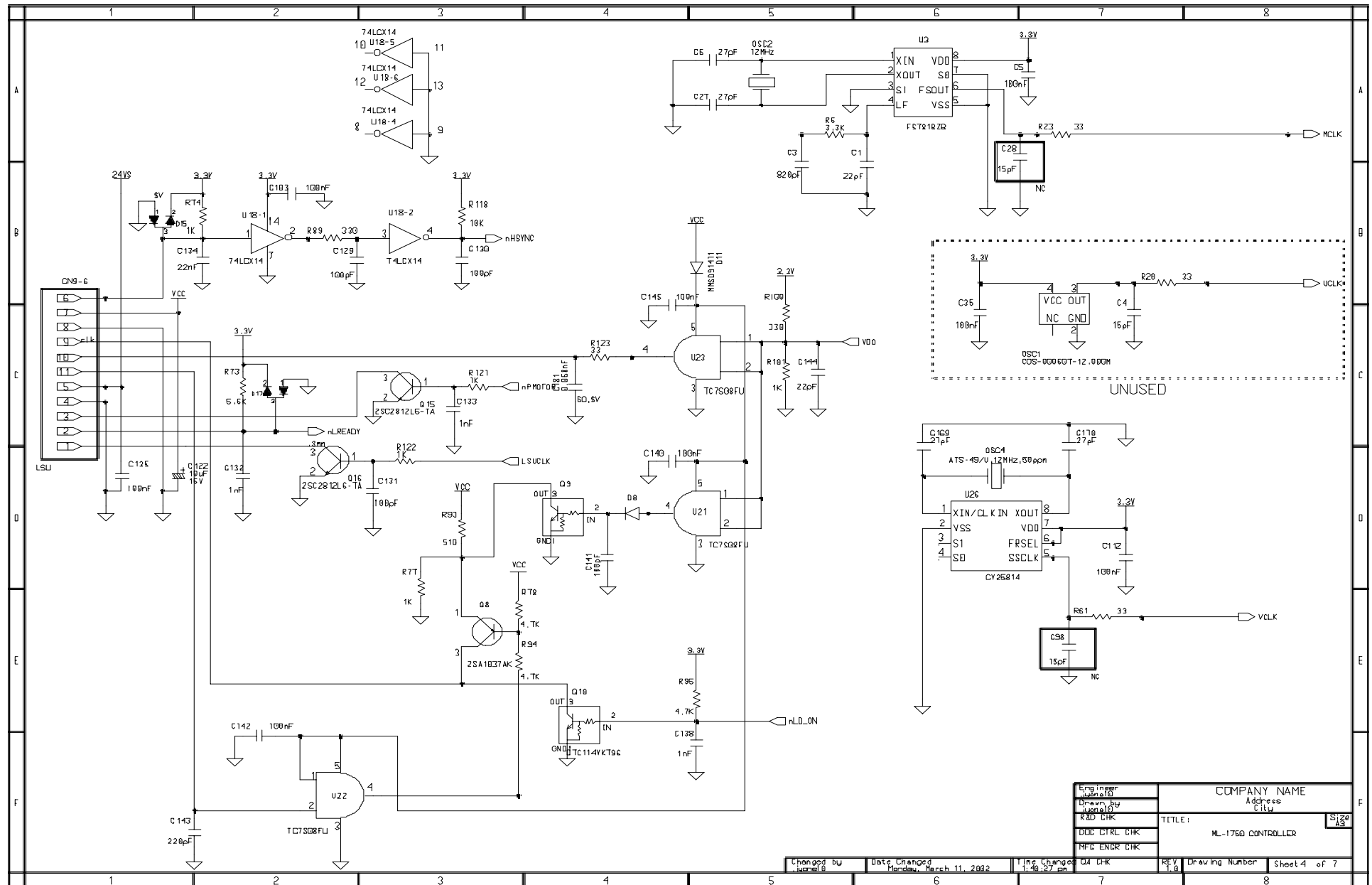

Engineer	COMPANY NAME
Drawn by	Address
Check	City
DATE	TITLE:
DATE	ML-1750 CONTROLLER
DATE	

Changed by	Date Changed	Title Changed	DA CHK	REV	Drawing Number	Sheet 4 of 7
June 8	Monday, March 11, 2002	1:40:27 pm		8		

PCL Main Circuit Diagram (5/7)

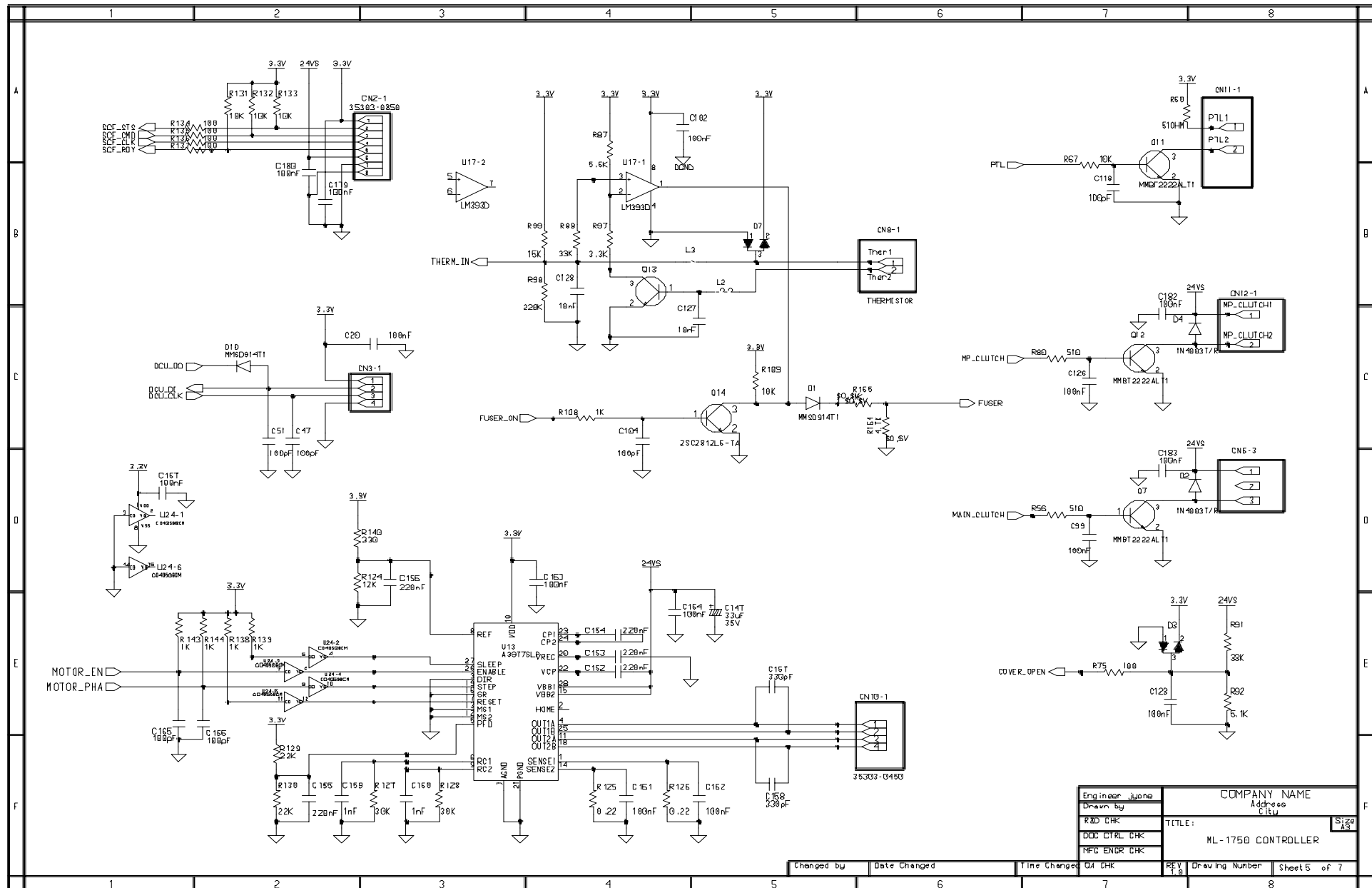

Eng in charge	_____	COMPANY NAME
Drawn by	_____	Address
RDY CHK	_____	City
DDT CTRL CHK	_____	Size
MFC ENDR CHK	_____	ML-1750 CONTROLLER

Changed by	Date Changed	Time Changed	QA CHK	Rev	Drawing Number	Sheet 5 of 7
------------	--------------	--------------	--------	-----	----------------	--------------

PCL Main Circuit Diagram (6/7)

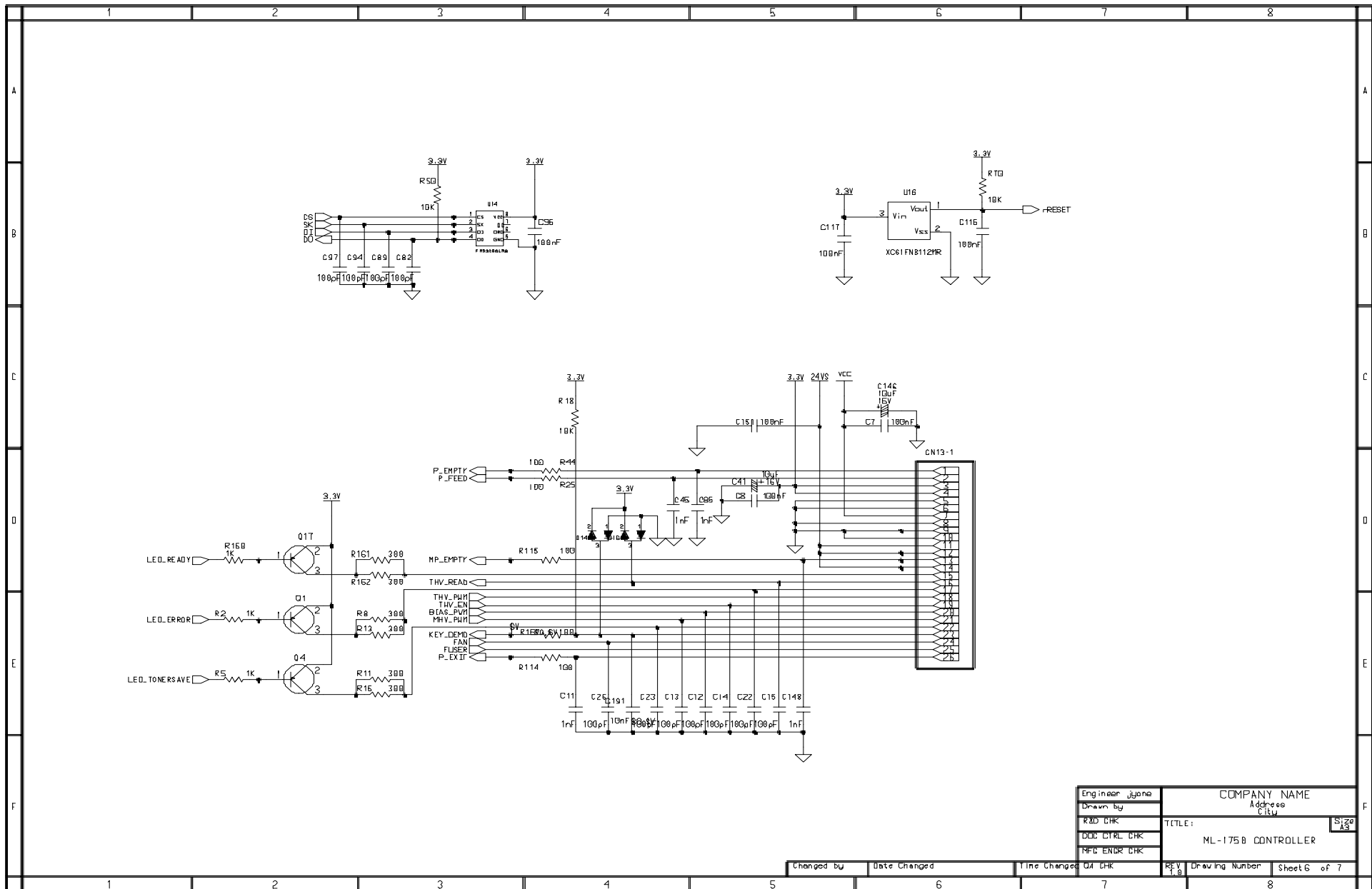

Engineer: june	COMPANY NAME
Drawn by:	Address
R&D CHK:	City
DOC CTRL CHK:	TITLE:
MFG ENDR CHK:	ML-175 B CONTROLLER
QA CHK:	Size: 18
REV: 8	Drawing Number
Time Changed:	Sheet 6 of 7

PCL Main Circuit Diagram (7/7)

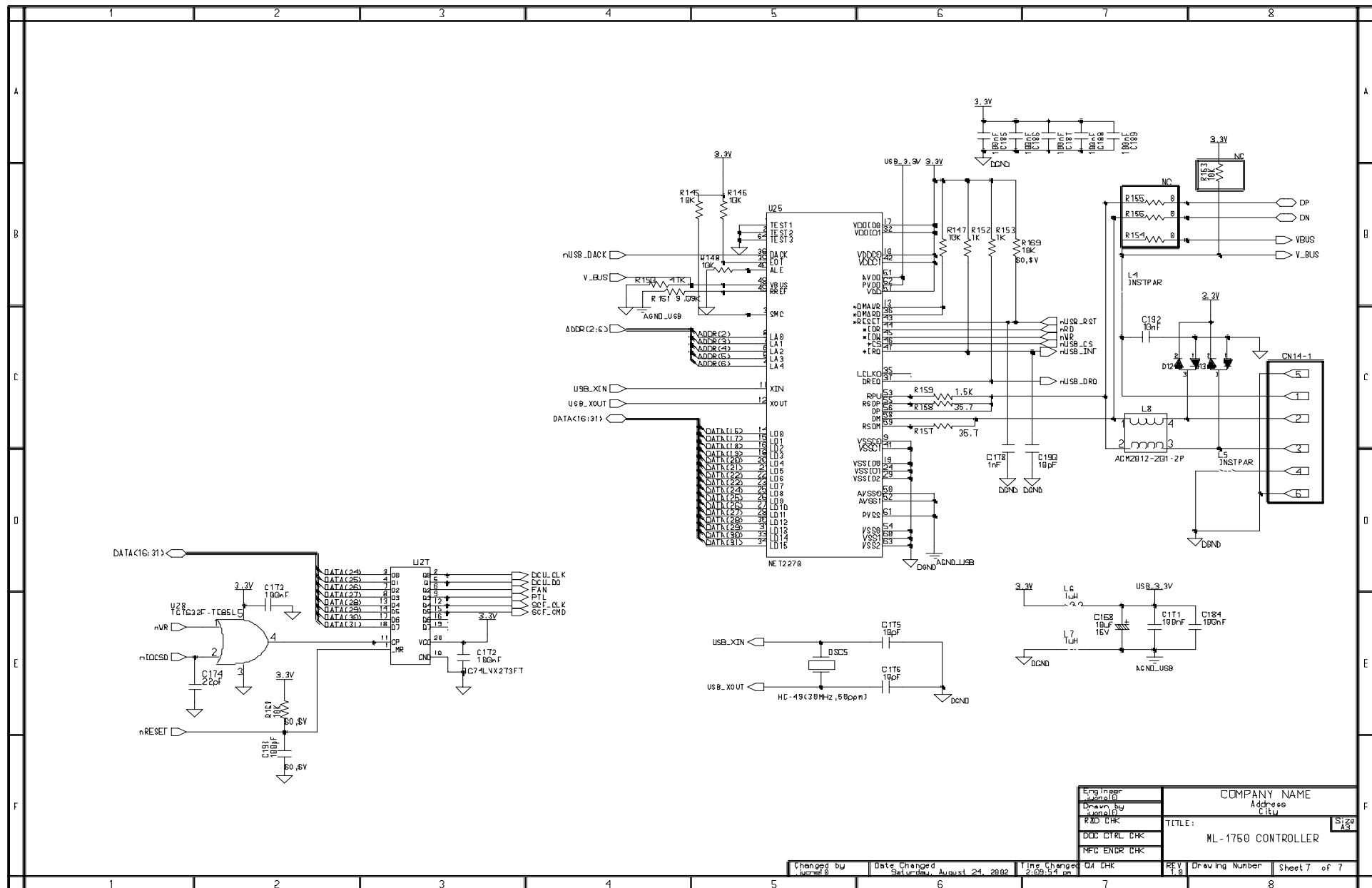

Engineer	COMPANY NAME
Drawn by	Address
Checked	City
Rev. 1.0	TITLE:
ML-1750 CONTROLLER	Size
	A3

Changed by	Date Changed	Time Changed	QA CHK	REV	Drawing Number	Sheet 7 of 7
hwe008	2008.08.24	2:09:54 pm		1.0		

11.2 SPL Main Circuit Diagram (1/5)

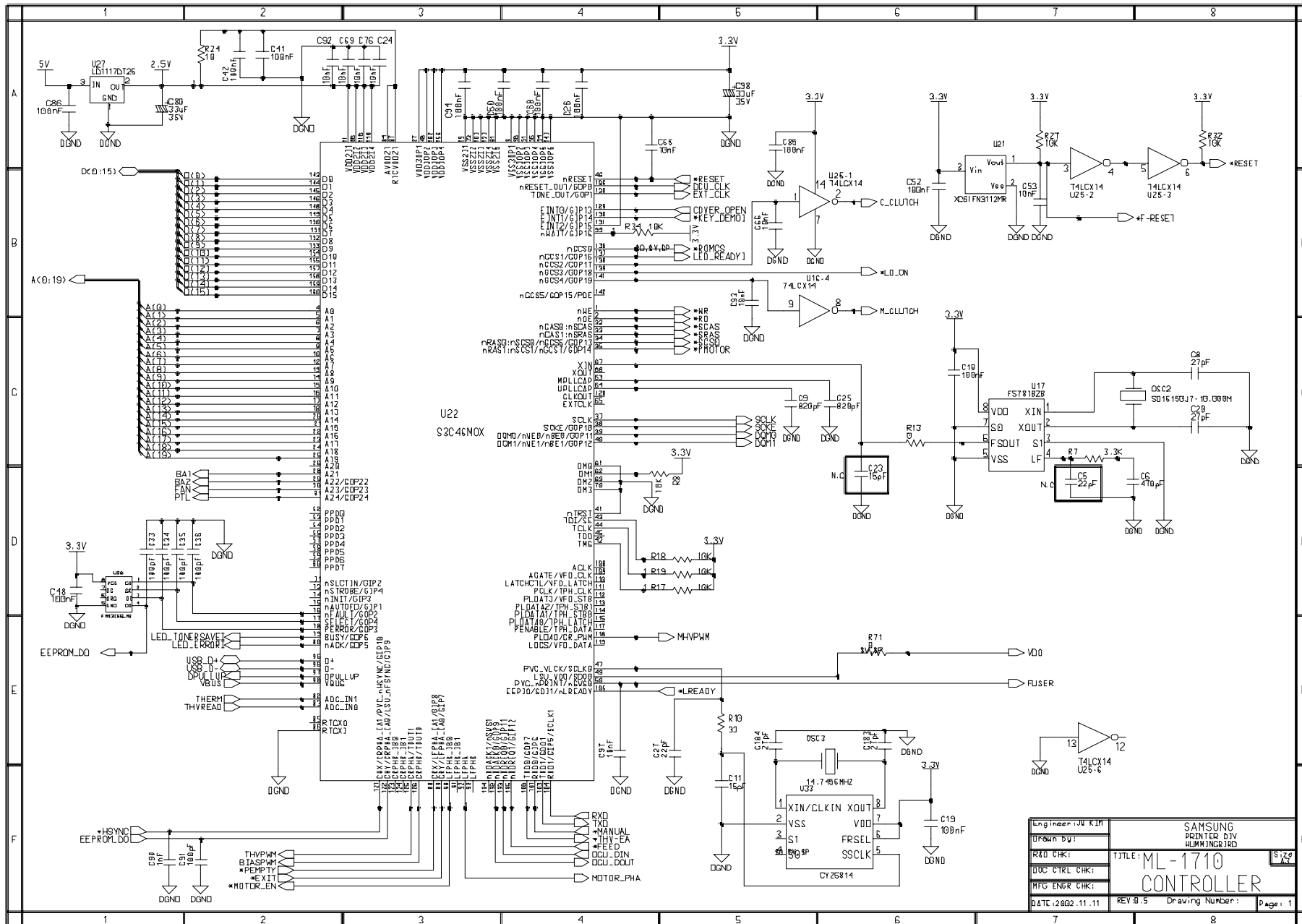

Engineer: J.W. Kim	SAMSUNG
Drawn by:	PRINTED BY: HWM/NG019D
R&D CHK:	TITLE: ML-1710
DOC CTRL CHK:	CONTROLLER
MFG ENGR CHK:	REV: 5.5
DATE: 2002.11.11	Drawing Number:
	Page: 1

SPL Main Circuit Diagram (2/5)

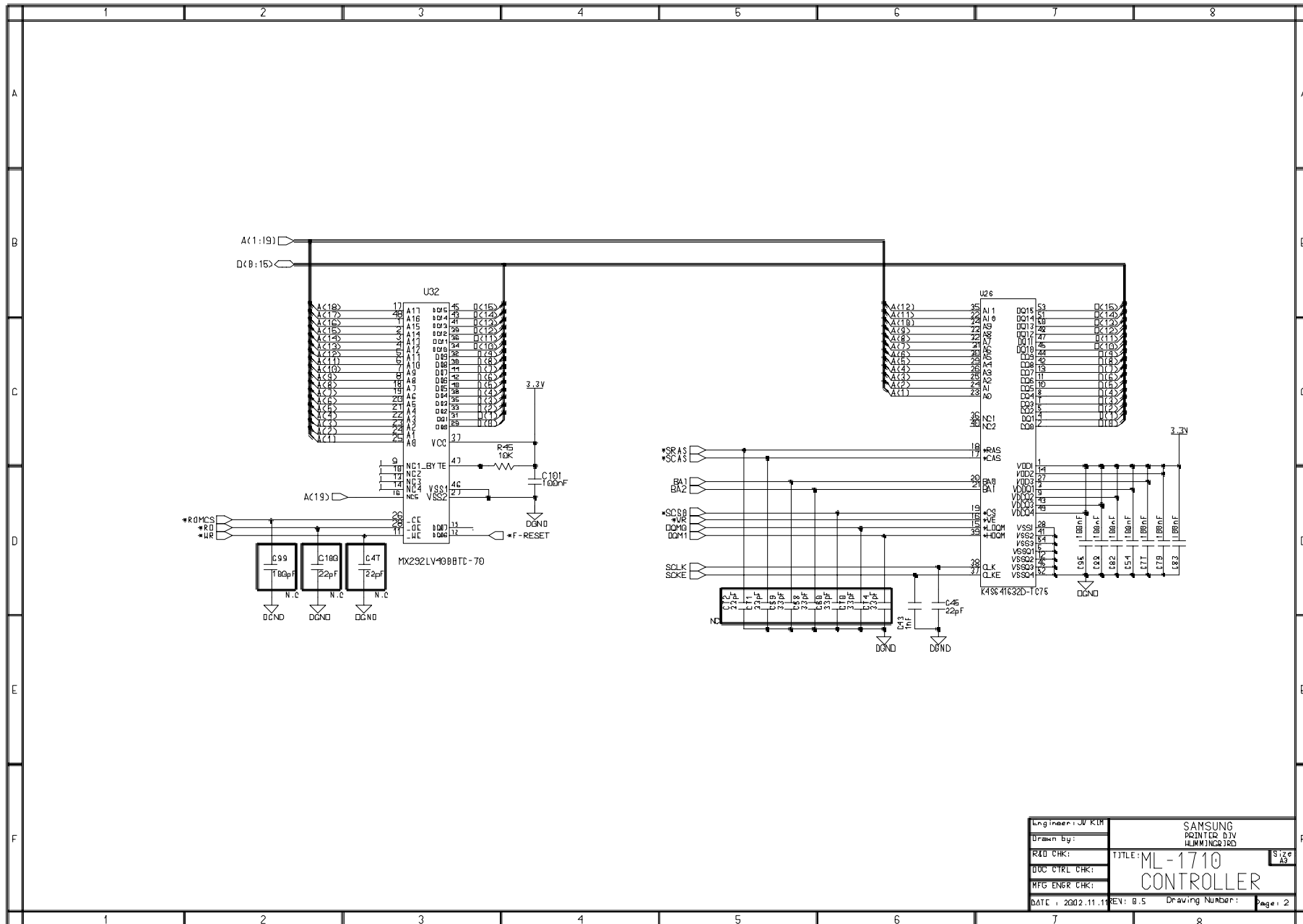

Engineer: J.W. KIM	SAMSUNG	
Drawn by:	PUNILIP, D.VN	
R&D CHK:	TITLE: ML-1710	Size: A3
UOC CTRL CHK:	CONTROLLER	
MFG ENGR CHK:		
DATE: 2002.11.11	REV: 0.5	Drawing Number: Page: 2

SPL Main Circuit Diagram (3/5)

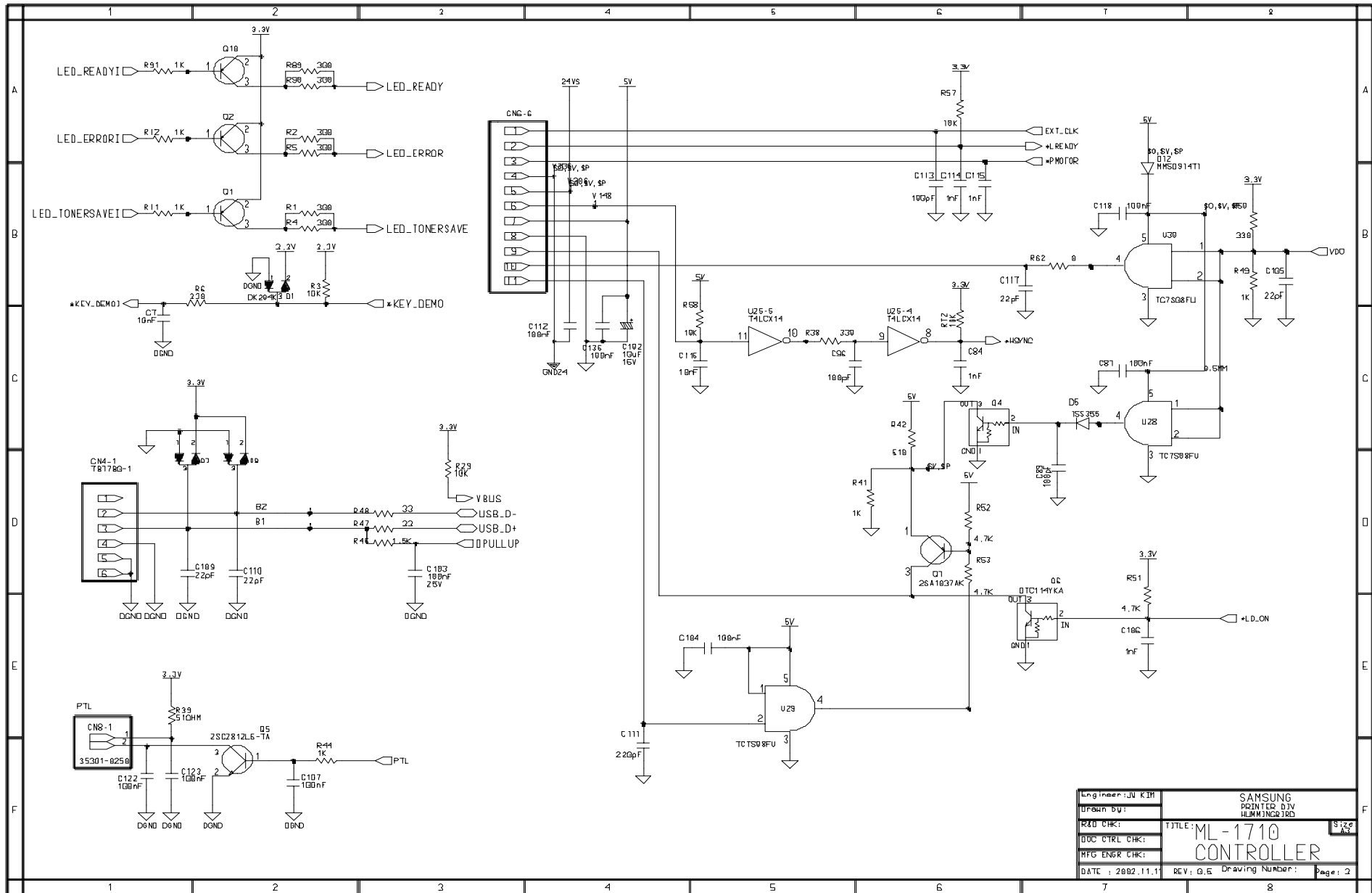

Engineer: JY KIM	SAMSUNG	
Drawn By:	PRINTER DIV	
R&D CHK:	HUMINGBIRD	
DOC CTRL CHK:	TITLE: ML-1710	
MFG ENGR CHK:	CONTROLLER	
DATE: 2002.11.1	REV: 0.5	Drawing Number: Page: 2

SPL Main Circuit Diagram (4/5)

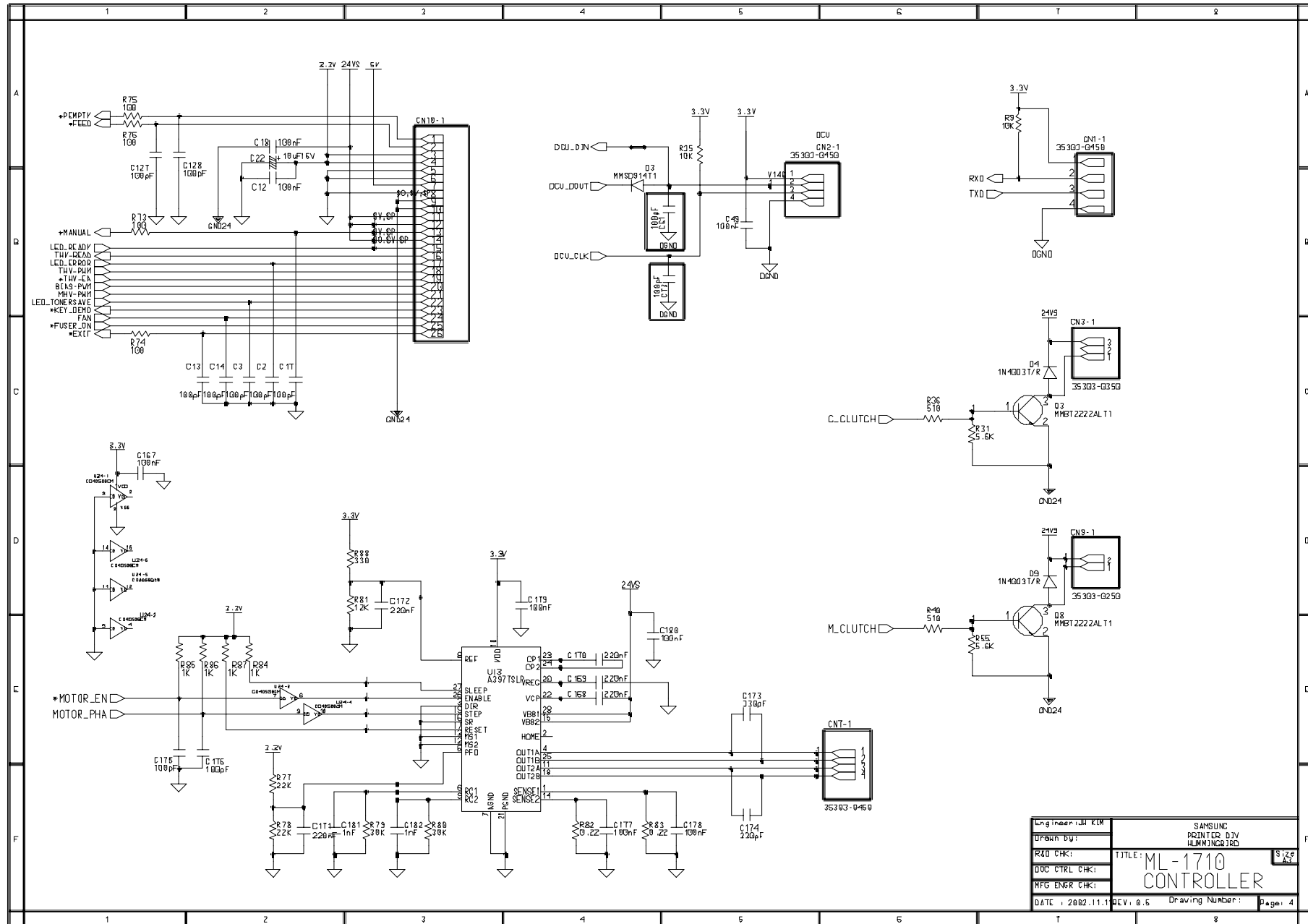

Engineer: J. KIM	SAMSUNG	
Drawn By:	P2212C.DJV	
RXD CHK:	TITLE: ML-1710	Size: A3
DDC CTRL CHK:	CONTROLLER	
RFG ENGR CHK:		
DATE: 2002.11.1	REV: 0.5	Drawing Number: Page: 4

SPL Main Circuit Diagram (5/5)

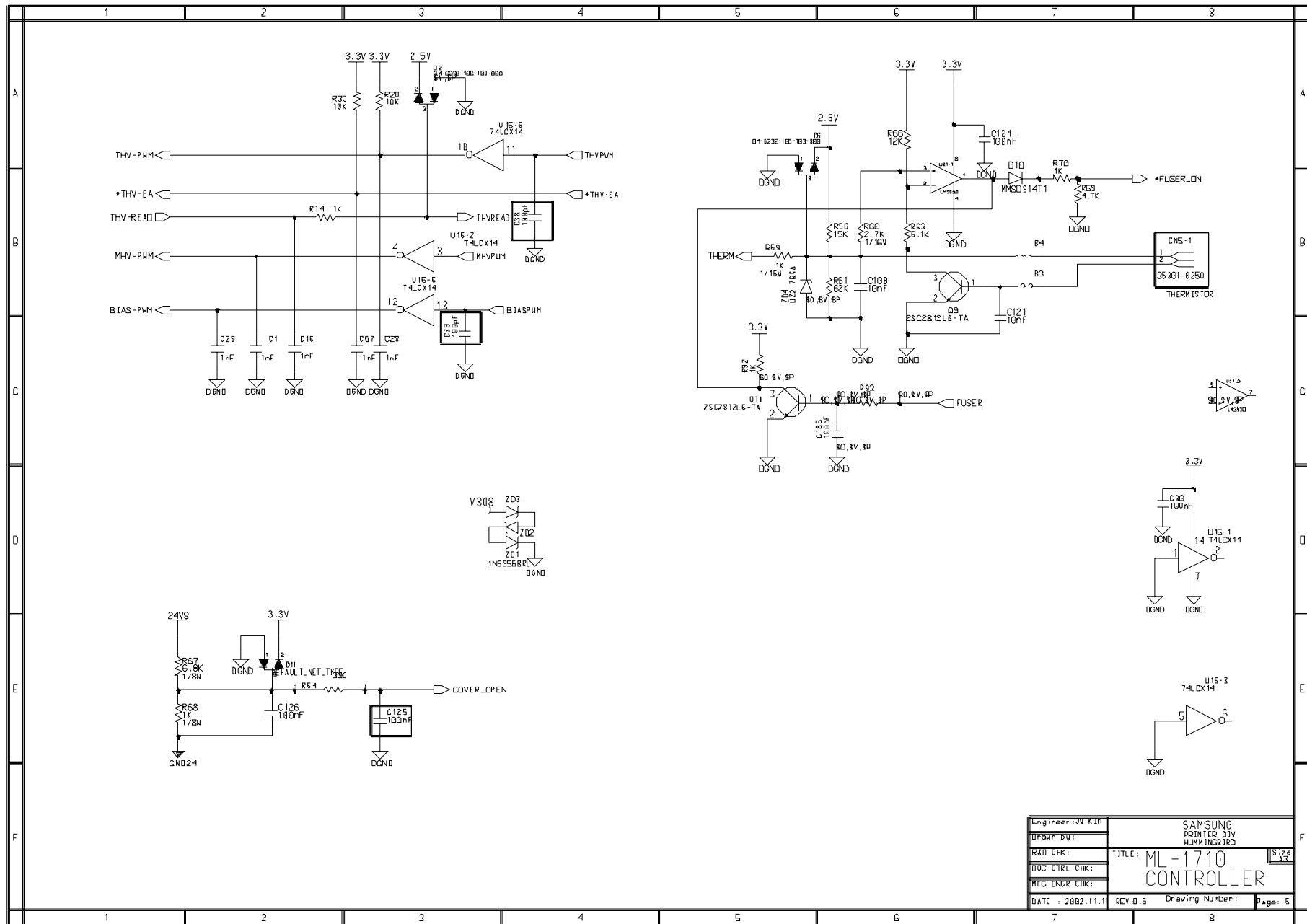

11.3 HVPS Circuit Diagram (1/2)

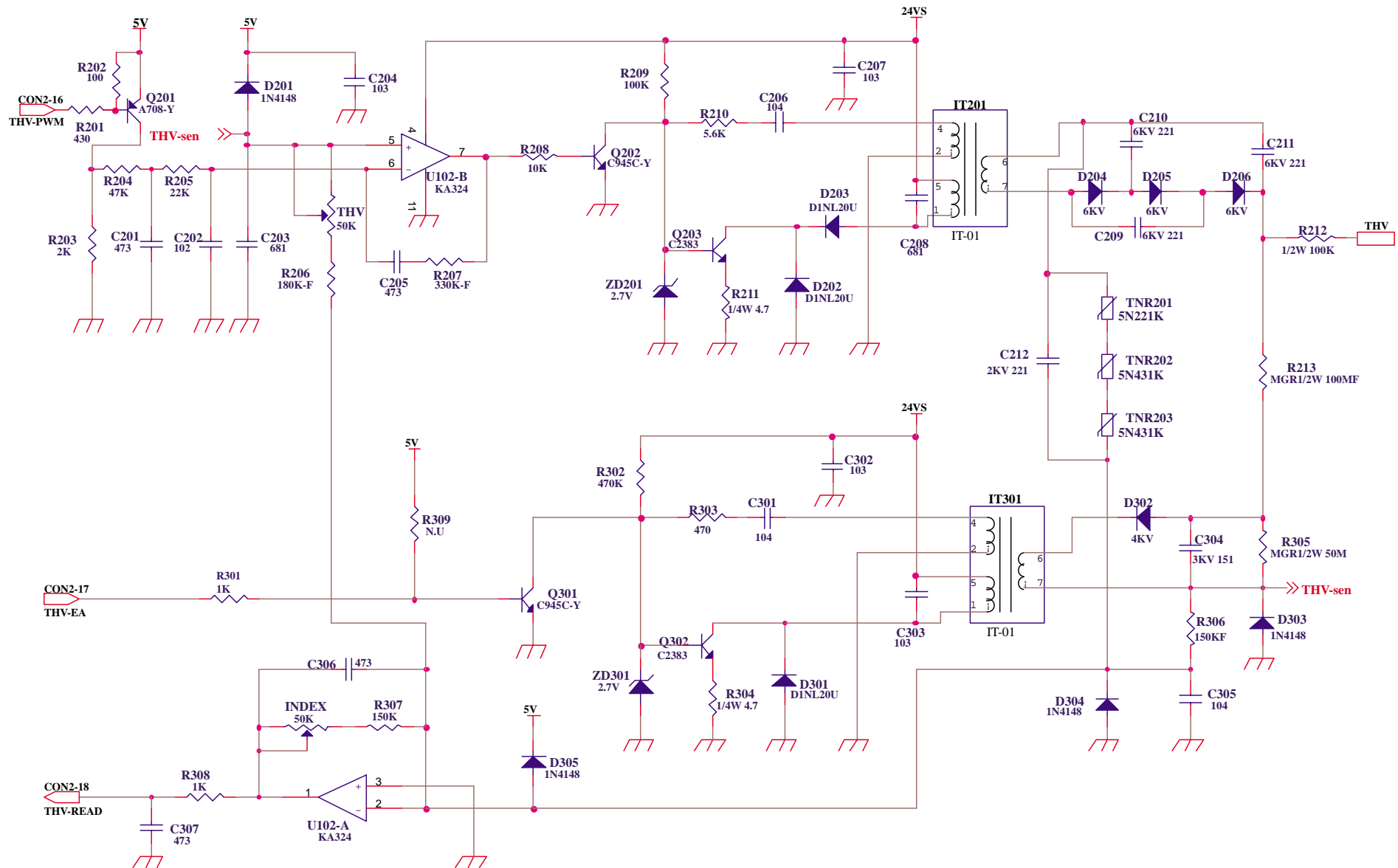

HVPS Circuit Diagram (2/2)

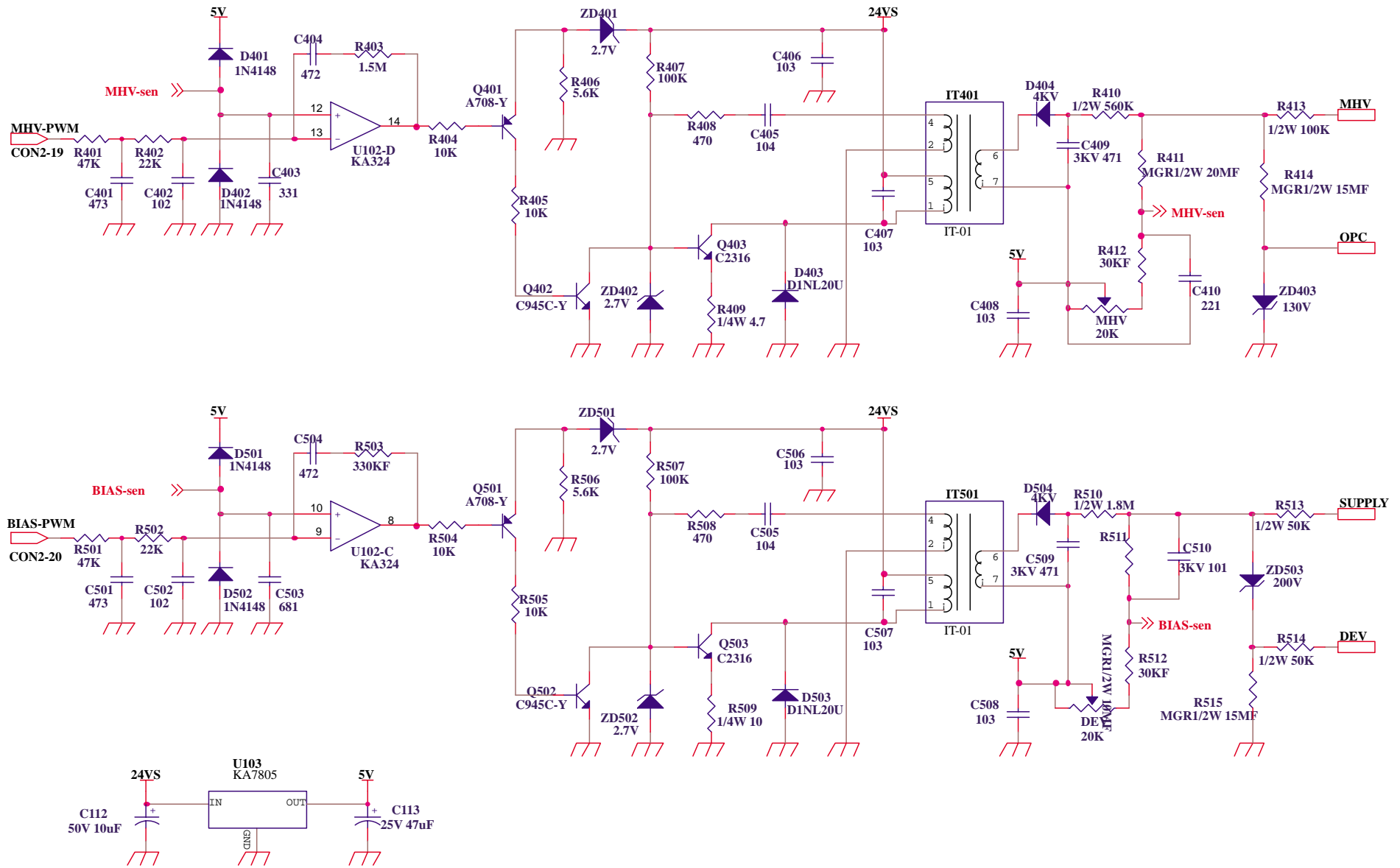

11.4 SMPS Circuit Diagram

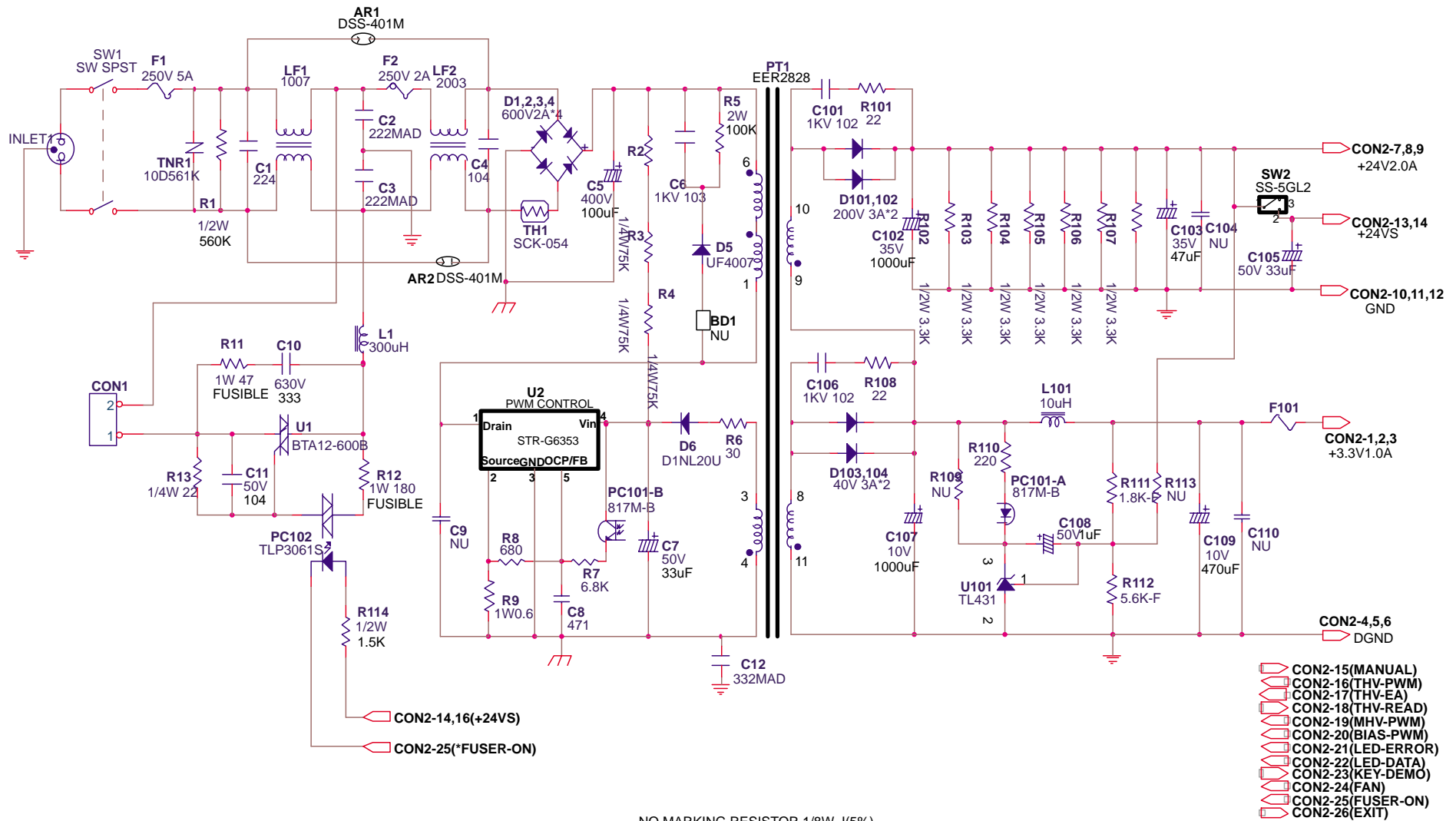

11.5 OTHER PBA Circuit Diagrams

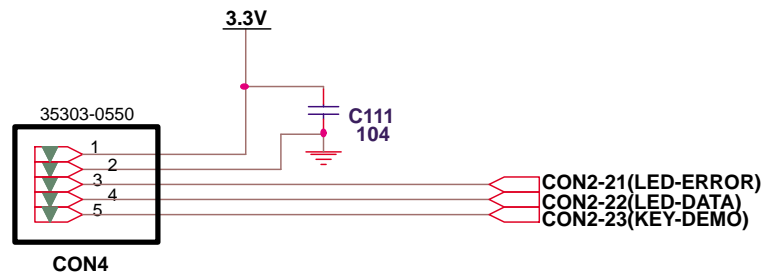
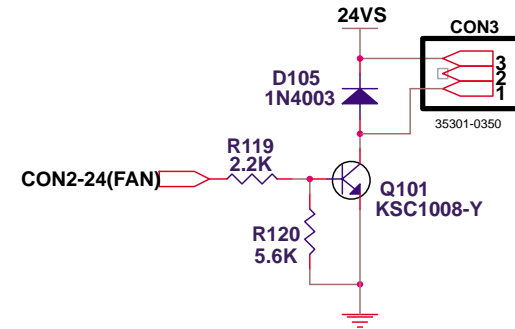
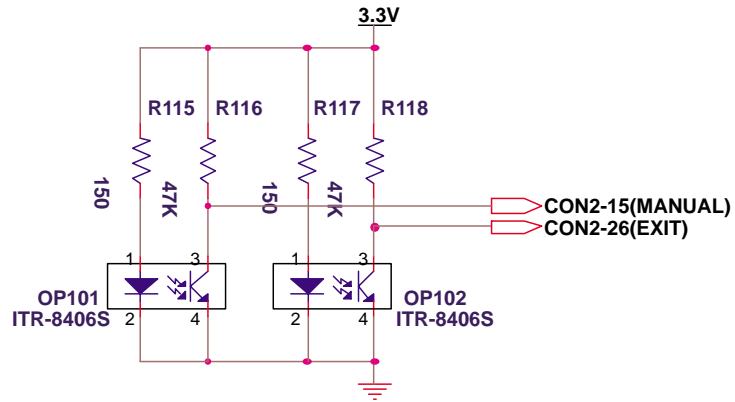

HUMMINGBIRD ERROR TEST

1. SERVICE ERROR

	Phenomenon	Measurement	DCU
Fuser ERROR	On Line/Error and Toner Save alternately light red and green for 1 second.	Check the fuser assembly, Controller and SMPS and AC wire	OPEN FUSER ERROR (DCU:60)
	On Line/Error and Toner Save alternately light orange and green for 1 second.	Check the fuser assembly, Controller and SMPS	OVER HEAT ERROR (DCU:68)
	On Line/Error and Toner Save alternately light red and green for 4 seconds.	Check the fuser assembly, Controller ,SMPS and AC wire	LOW HEAT ERROR (DCU:62)
LSU ERROR	On Line/Error and Toner Save alternately light green and green for 1 second.	Check the LSU, Controller and Harness	LSU NOT READY ERROR PMOTOR ERROR (DCU:95)
	Main motor stops right after paper is feeded. Then On Line/Error and Toner Save alternately light green and green for 4 seconds.	Check the LSU, Controller and Harness	LSU NOT READY ERROR HSYNC ERROR (DCU:96)

2. PAPER JAM

	Phenomenon	Measurement	DCU
PAPER JAM	On Line/Error Lights red	Check the Feed Clutch Operation and Controller	JAM0 (DCU:71)
	On Line/Error Lights red	Check the Feed Sensor and Controller	JAM1 (DCU:72)
	On Line/Error Lights red	Check the Exit Sensor, Fuser Ass'y and Controller	JAM2 (DCU:73)

3.

Item	Phenomenon	Measurement	DCU
COVER OPEN	On Line/Error Lights red	Check the cover open switch	(DCU:64)
PAPER EMPTY	On Line/Error Lights red	Check if there are papers in cassette.	(DCU:70)

DCU Function Table for ML-1710 Series

No.	Function	Enter	Up/Down	Stop	Remark
00	Motor	Motor Run		Motor Stop	
01	MHV	Mhv On		Mhv Off	-1550V
02	THV(-)	Thv Negative On		Thv Negative Off	
03	THV(+)	Thv On		Thv Off	+1300V
04	DEV	Dev On	Supply	DEV	Dev Off
			0 : -630V	0 : -430V	
05	LSU	LSU Run	On Off Ready	LSU Stop	
06	PickUp	Pickup On		Pickup Off	
07	PEmpty		Paper Empty		
08	Sensor		Exit Feed		
09	Cover		Cover Open		
10	Fuser	Fuser On		Fuser Off	
11	HotBurn	HotBurn On			
12	Clean Print	Clean Printing			
13	Thv Reference		low adequate high		
14	PTL	PTL On		PTL Off	
15	FAN	Fan On		Fan Off	
16	Manual PickUp	Manual Pickup On		Manual Pickup Off	
17	Manual Sensor		Manual Sensor		

**This manual is stated and
provided for service description.**

All rights reserved. Any parts of the information in this manual are prohibited from free duplication, use or translation without prior written approval except in cases allowed by the Copyright Act.

Specifications are subject to change without prior notice.

Samsung Electronics
Digital Printing CS Group
Copyright (c) 2003. 01

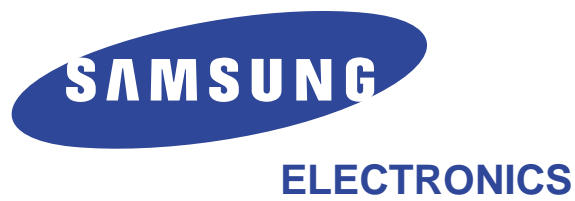

This service manual is also provided on the web,
the ITSELF system of Samsung Electronics Co., Ltd.
<http://itself.sec.samsung.co.kr>

© Samsung Electronics Co.,Ltd. January 2003
Printed in Korea.

VERSION NO. : 1.00 CODE : JC-0084A