

RoHS Compliant

SATA-Disk Module 4

SDM4 7P/270D Middle Profile Specifications

July 5th, 2013

Version 1.3



Apacer Technology Inc.

4th Fl., 75 Hsin Tai Wu Rd., Sec.1, Xizhi, New Taipei City, Taiwan 221

Tel: +886-2-2698-2888 Fax: +886-2-2698-2889

www.apacer.com

Features:

- **Standard Serial ATA Revision 2.6**
 - Compliance with SATA Revision 2.6 specifications
 - SATA 3.0 Gbps
 - ATA-compatible command set
- **Capacities**
 - 2, 4, 8, 16, 32 GB
- **Performance***
 - Burst read/write: 300 MB/sec
 - Sustained read: up to 85 MB/sec
 - Sustained write: up to 80 MB/sec
- **Intelligent endurance design**
 - Built-in hardware ECC, enabling up to 16/24 bit correction per 1K bytes
 - Static/dynamic wear-leveling
 - Flash bad-block management
 - S.M.A.R.T.
 - Power Failure Management
 - ATA Secure Erase
 - TRIM
- **NAND Flash Type: SLC**
- **Temperature ranges**
 - Operation:
 - Standard: 0°C to 70°C (32 ~ 158°F)
 - Extended: -40 ~ +85°C (-40° ~ 185°F)
 - Storage: -40°C to 100°C (-40° ~ 212°F)
- **Supply voltage**
 - 5.0 V ± 5%
- **Power consumption (typical)***
 - Active mode: 233 mA@5.0 V
 - Idle mode: 75 mA@5.0 V
- **Connector type**
 - 7-pin signal connector
 - Power segment in two types: power cable and power cable-less types
- **Form factor**
 - SATA Disk Module (58.00 x 24.00 x 1.00**, unit: mm)
- **Shock & Vibration*****
 - Shock: 1500 G
 - Vibration: 15 G
- **MTBF: >2,000,000 hours**
- **RoHS compliant**
- **Write Protect (optional)**
 - Enabled by onboard hardware switch

*Varies from capacities. The values for performances and power consumptions presented are typical and may vary depending on flash configurations or platform settings. The term idle refers to the standby state of the device.

**Only the thickness of the module. For details, please see "Physical Characteristics".

***Non-operating

Table of Contents

1. GENERAL DESCRIPTION	3
2. FUNCTIONAL BLOCK	3
3. PIN ASSIGNMENTS	4
4. PRODUCT SPECIFICATIONS	6
4.1 CAPACITY	6
4.2 PERFORMANCE	6
4.3 ENVIRONMENTAL SPECIFICATIONS	7
4.4 MEAN TIME BETWEEN FAILURES (MTBF)	7
4.5 CERTIFICATION AND COMPLIANCE	7
5. FLASH MANAGEMENT	8
5.1 ERROR CORRECTION/DETECTION	8
5.2 BAD BLOCK MANAGEMENT	8
5.3 WEAR LEVELING	8
5.4 POWER FAILURE MANAGEMENT	8
5.5 ATA SECURE ERASE	8
5.6 S.M.A.R.T.	9
5.7 TRIM	9
6. SOFTWARE INTERFACE	10
6.1 COMMAND SET	10
7. ELECTRICAL SPECIFICATION	11
8. PHYSICAL CHARACTERISTICS	12
8.1 POWER CABLE TYPE.....	12
8.2 POWER CABLE-LESS TYPE	13
8.3 WRITE PROTECT SWITCH (OPTIONAL).....	14
9. PRODUCT ORDERING INFORMATION	15
9.1 PRODUCT CODE DESIGNATIONS	15

1. General Description

Apacer's SATA-Disk Module 4 (SDM4) is a high-performance, embedded SSD DOM (Disk on Module) designed to replace the conventional SATA storage devices. SDM4 can be fitted into a standard Serial ATA connectors commonly found in desktops, IT-STB, industrial PC and thin client systems. In addition, SDM4 provides an innovative way for design-in clients with compact host computing systems.

Apacer's SDM4 is built in with an efficient microcontroller that drives the potential of NAND flash and delivers optimal performance. With its compact form factor and SATA 3.0 Gbps interface, this product is well suited for embedded flash storage applications offering customizable and expanded functionalities as well as more cost-effective designs, better performance and increased reliability.

2. Functional Block

SDM4 includes the SATA and Flash Management controllers, and flash media, as well as the SATA standard interface. Figure 2-1 shows the functional block diagram.

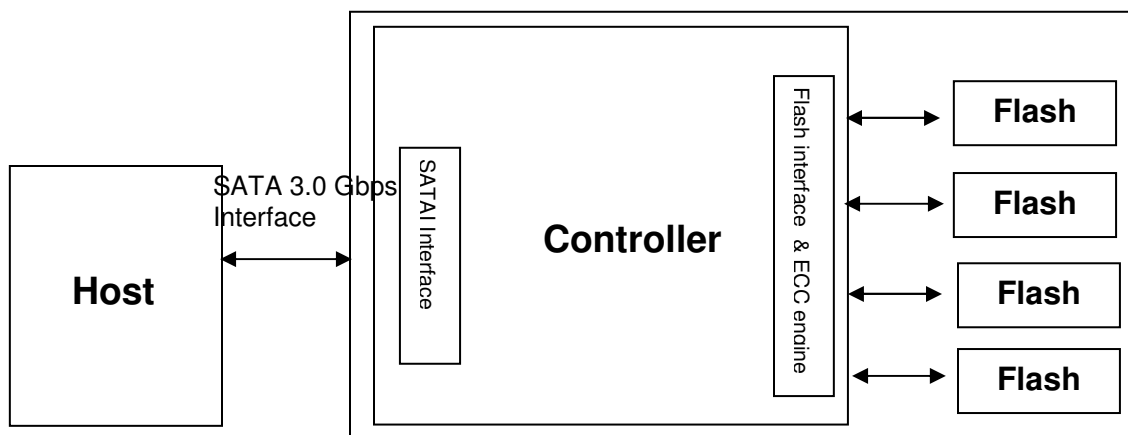

Figure 2-1: Functional block diagram

3. Pin Assignments

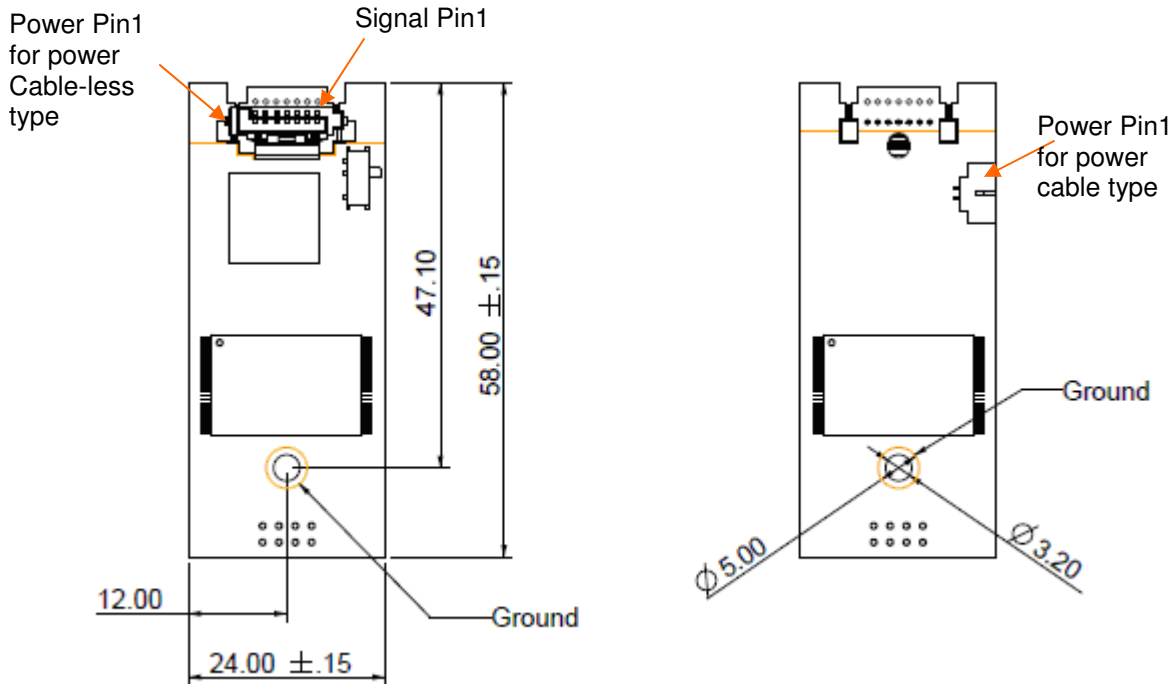

Table 3-1: Signal segment

Name	Type	Description
Pin 1	GND	
Pin 2	RxP	+ Differential Receive Signal
Pin 3	RxN	- Differential Receive Signal
Pin 4	GND	
Pin 5	TxN	- Differential Transmit Signal
Pin 6	TxP	+ Differential Transmit Signal
Pin 7	GND	

Table 3-2: Power segment

Name	Description
Pin 1	VCC (5V)
Pin 2	GND

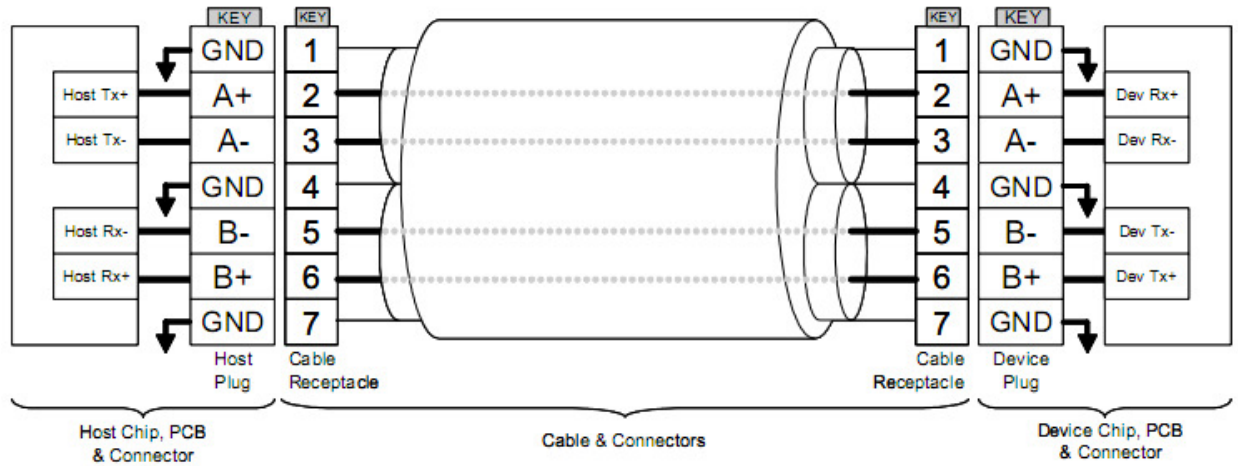

Figure 3-1: SATA Cable/Connector Connection Diagram

The connector on the left represents the Host with TX/RX differential pairs connected to a cable. The connector on the right shows the Device with TX/RX differential pairs also connected to the cable. Notice also the ground path connecting the shielding of the cable to the Cable Receptacle.

4. Product Specifications

4.1 Capacity

Capacity specification of SDM4 product family is available as shown in Table 4-1. It lists the specific capacity and the default numbers of heads, sectors and cylinders for each product line.

Table 4-1: Capacity specifications

Capacity	Total bytes*	Cylinders	Heads	Sectors	Max LBA
2 GB	2,011,226,112	3,897	16	63	3,928,176
4 GB	4,011,614,208	7,773	16	63	7,835,184
8 GB	8,012,390,400	15,525	16	63	15,649,200
16 GB	16,013,942,784	16,383	16	63	31,277,232
32 GB	32,017,047,552	16,383	16	63	62,533,296

*Display of total bytes varies from file systems which means not all of the bytes can be used for storage.

**Cylinders, heads or sectors are not applicable for these capacities. Only LBA addressing applies.

LBA count addressed in the table above indicates total user storage capacity and will remain the same throughout the lifespan of the device. However, the total usable capacity of the SSD is most likely to be less than the total physical capacity because a small portion of the capacity is reserved for device maintenance usages.

4.2 Performance

Performances of SDM4 are listed below in table 4-2.

Table 4-2: Performance (Typical)

Capacity	2 GB	4 GB	8 GB	16 GB	32 GB
Performance					
Sustained read (MB/s)	75	80	80	85	85
Sustained write (MB/s)	28	55	55	80	80

Note: Results may differ from various flash configurations or host system settings.

4.3 Environmental Specifications

Environmental specification of SDM4 series follows military standards, indicated in Table 4-3.

Table 4-3 SDM4 environmental specifications

Item	Specification
Operating temperature	0~70(°C)
Extended temperature	-40 ~ +85(°C)
Storage temperature	-40~100(°C)
Vibration (non-operating)	10~2000(Hz), 15(G), sine wave, X, Y, Z axis
Vibration (operating)	20~2000(Hz), 7.69 (Grms), random wave, X, Y, Z axis
Shock (non-operating)	1500(G) half-sine wave, $\pm X$, $\pm Y$, $\pm Z$ axis
Shock (operating)	50(G), half sine wave, $\pm X$, $\pm Y$, $\pm Z$ axis

4.4 Mean Time Between Failures (MTBF)

Mean Time Between Failures (MTBF) is predicted based on reliability data for the individual components in SDM4. The prediction result for SDM4 is more than 2,000,000 hours.

Notes about the MTBF:

The MTBF is predicated and calculated based on "Telcordia Technologies Special Report, SR-332, Issue 2" method.

4.5 Certification and Compliance

SDM4 complies with the following standards:

- CE
- FCC
- RoHS
- MIL-STD-810

5. Flash Management

5.1 Error Correction/Detection

SDM4 implements a hardware ECC scheme, based on the BCH algorithm. It can detect and correct up to 16 bits or 24 bits error in 1K bytes.

5.2 Bad Block Management

Current production technology is unable to guarantee total reliability of NAND flash memory array. When a flash memory device leaves factory, it comes with a minimal number of initial bad blocks during production or out-of-factory as there is no currently known technology that produce flash chips free of bad blocks. In addition, bad blocks may develop during program/erase cycles. When host performs program/erase command on a block, bad block may appear in Status Register. Since bad blocks are inevitable, the solution is to keep them in control. Apacer flash devices are programmed with ECC, block mapping technique and S.M.A.R.T to reduce invalidity or error. Once bad blocks are detected, data in those blocks will be transferred to free blocks and error will be corrected by designated algorithms.

5.3 Wear Leveling

Flash memory devices differ from Hard Disk Drives (HDDs) in terms of how blocks are utilized. For HDDs, when a change is made to stored data, like erase or update, the controller mechanism on HDDs will perform overwrites on blocks. Unlike HDDs, flash blocks cannot be overwritten and each P/E cycle wears down the lifespan of blocks gradually. Repeatedly program/erase cycles performed on the same memory cells will eventually cause some blocks to age faster than others. This would bring flash storages to their end of service term sooner. Wear leveling is an important mechanism that level out the wearing of blocks so that the wearing-down of blocks can be almost evenly distributed. This will increase the lifespan of SSDs. Commonly used wear leveling types are Static and Dynamic.

5.4 Power Failure Management

Power Failure Management plays a crucial role when experiencing unstable power supply. Power disruption may occur when users are storing data into the SSD. In this urgent situation, the controller would run multiple write-to-flash cycles to store the metadata for later block rebuilding. This urgent operation requires about several milliseconds to get it done. At the next power up, the firmware will perform a status tracking to retrieve the mapping table and resume previously programmed NAND blocks to check if there is any incompleteness of transmission.

5.5 ATA Secure Erase

ATA Secure Erase is an ATA disk purging command currently embedded in most of the storage drives. Defined in ATA specifications, (ATA) Secure Erase is part of Security Feature Set that allows storage drives to erase all user data areas. The erase process usually runs on the firmware level as most of the ATA-based storage media currently in the market are built-in with this command. ATA Secure Erase can securely wipe out the user data in the drive and protects it from malicious attack.

5.6 S.M.A.R.T.

S.M.A.R.T. is an abbreviation for Self-Monitoring, Analysis and Reporting Technology, a self-monitoring system that provides indicators of drive health as well as potential disk problems. It serves as a warning for users from unscheduled downtime by monitoring and displaying critical drive information. Ideally, this should allow taking proactive actions to prevent drive failure and make use of S.M.A.R.T. information for future product development reference.

Apacer devices use the standard SMART command B0h to read data out from the drive to activate our S.M.A.R.T. feature that complies with the ATA/ATAPI specifications. S.M.A.R.T. Attribute IDs shall include initial bad block count, total later bad block count, maximum erase count, average erase count, power on hours and power cycle. When the S.M.A.R.T. Utility running on the host, it analyzes and reports the disk status to the host before the device reaches in critical condition.

Note: attribute IDs may vary from product models due to various solution design and supporting capabilities.

5.7 TRIM

TRIM, though in capital letters usually, is a memory computation command rather than an abbreviation. It is mainly a SATA command that enables the operating system to inform the SSD (Solid State Drive) which blocks of previously stored data are no longer valid, due to erases by the host or operating system, such as file deletions or disk formatting. Once notified, SSD will begin the discard of the invalid LBAs and retain more space for itself, in fact, the discarded is no longer recoverable.

When an LBA is replaced by the operating system, as with overwrite of a file, the SSD is informed that the originally occupied LBA is determined as no longer in use or invalid. The SSD will not save those blocks in garbage collected sectors. Noticeably, a file deletion command by host or operating system never actually erases the actual content, rather, just the file is marked as deleted. This issue is even specifically noticeable for flash based memory devices, such as SSDs. In fact, an SSD will keep garbage collecting the invalid, previously occupied LBAs, if it is not informed that these LBAs can be erased. Thus, the SSD would experience a significant performance downfall.

6. Software Interface

6.1 Command Set

This section defines the software requirements and the format of the commands the host sends to SDM4. Commands are issued to SDM4 by loading the required registers in the command block with the supplied parameters, and then writing the command code to the Command register.

Table 6-1: Command set

Code	Command	Code	Command
E5h	Check Power Mode	F3h	Security Erase Prepare
06h	Data Set Management	F4h	Security Erase Unit
90h	Execute Device Diagnostic	F5h	Security Freeze Lock
E7h	Flush Cache	F1h	Security Set Password
EAh	Flush Cache EXT	F2h	Security Unlock
ECh	Identify Device	70h	Seek
E3h	Idle	EFh	Set Features
E1h	Idle Immediate	C6h	Set Multiple Mode
91h	Initialize Device Parameters	E6h	Sleep
C8h	Read DMA	B0h	SMART
25h	Read DMA EXT	E2h	Standby
C4h	Read Multiple	E0h	Standby Immediate
29h	Read Multiple EXT	CAh	Write DMA
20h	Read Sector	35h	Write DMA EXT
24h	Read Sector EXT	C5h	Write Multiple
40h	Read Verify Sectors	39h	Write Multiple EXT
42h	Read Verify Sectors EXT	30h	Write Sector
10h	Recalibrate	34h	Write Sector EXT
F6h	Security Disable Password		

7. Electrical Specification

Table 7-1: Operating range

Item	Description
Required voltage	5V±5% (4.75-5.25V)
Operating temperature	0°C to +70°C (standard) -40°C to 85°C (extended)

Table 7-2: Power consumption (typical)

Modes \ Capacity	2 GB	4 GB	8 GB	16 GB	32 GB
	Active (mA)	180	215	215	220
Idle (mA)	70	72	75	75	75

Note: Results may differ from various flash configurations or platforms.

8. Physical Characteristics

8.1 Power Cable Type

7-pin/270 Degree Module

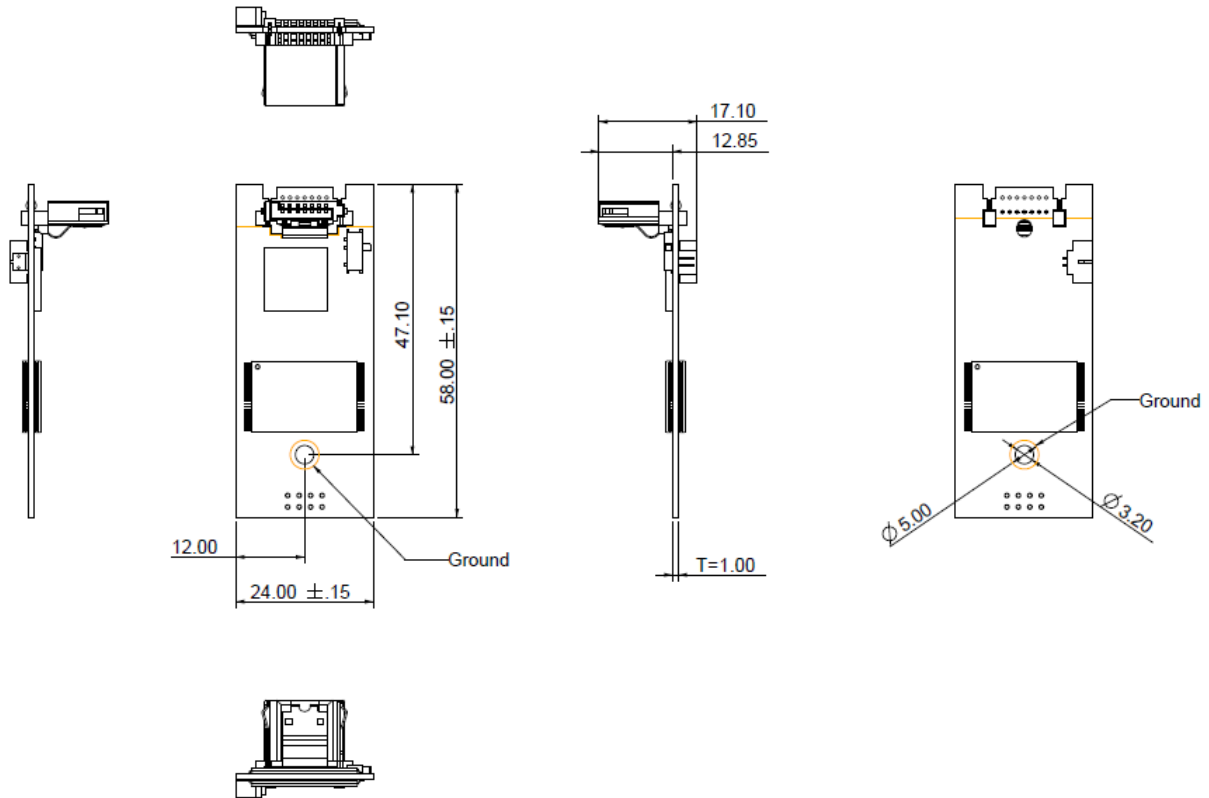

Unit: mm
Tolerance: ± 0.25

SATA-Disk Module 4 APSDMxxxxF5AN-PXXX

8.2 Power Cable-less Type

7-pin/270 Degree Module

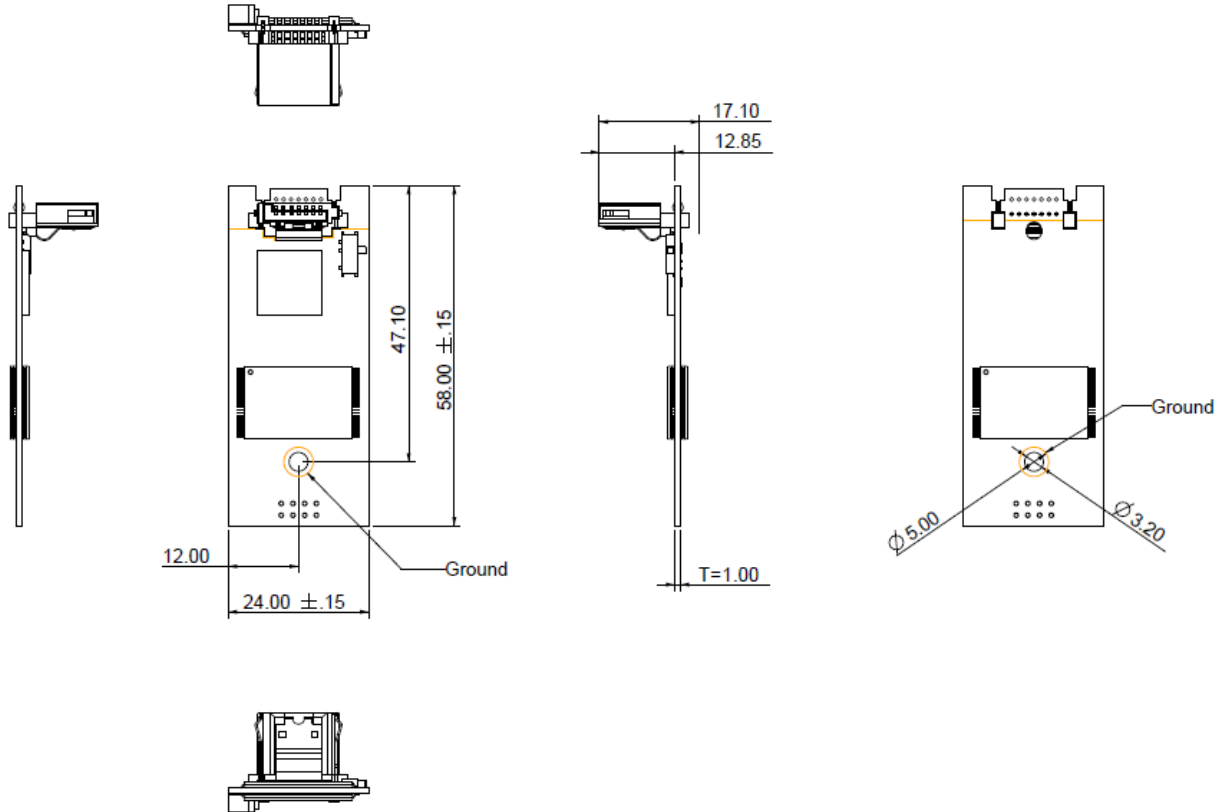

Unit: mm
Tolerance: ± 0.25

8.3 Write Protect Switch (optional)

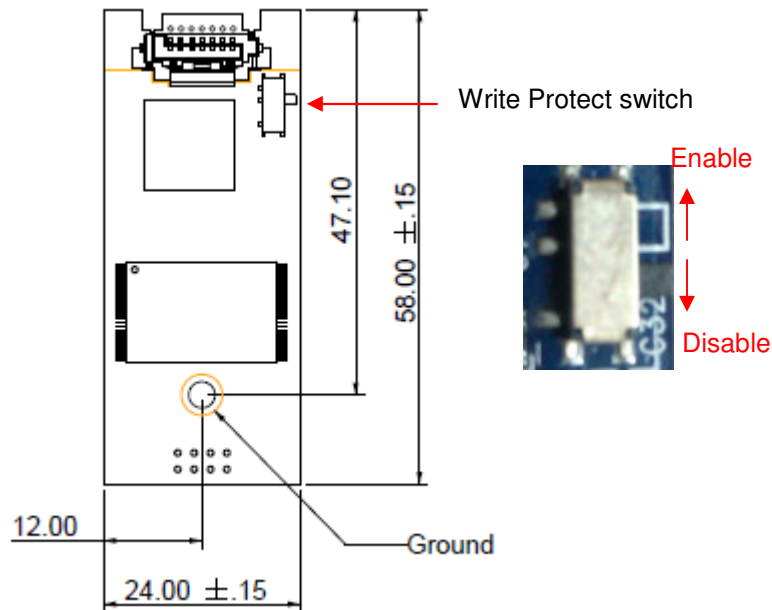

Description of Apacer Write Protect:

Apacer implements the Virtual Write scheme that allows write commands to go through the flash controller and data temporarily stored, but no data has been actually written into the flash. Since the Virtual Write scheme runs at device level, it requires no software or driver installation and is independent from the host OS.

9. Product Ordering Information

9.1 Product Code Designations

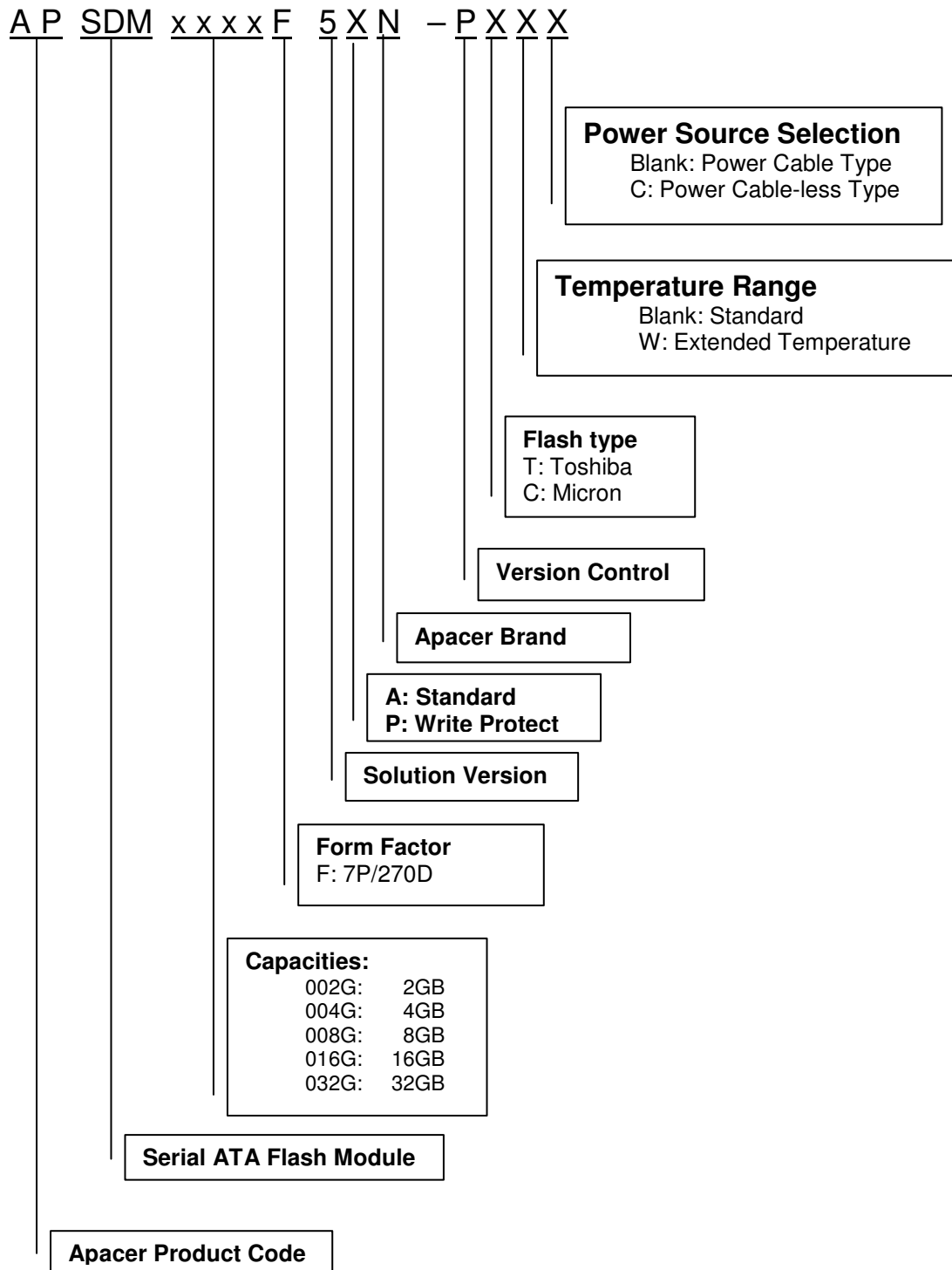

9.2 Valid Combinations

7P/270D MP: Power Cable Type

Capacity	Standard	Extended Temperature
2GB	APSDM002GF5AN-PT	APSDM002GF5AN-PTW
4GB	APSDM004GF5AN-PT	APSDM004GF5AN-PTW
8GB	APSDM008GF5AN-PT	APSDM008GF5AN-PTW
16GB	APSDM016GF5AN-PC	APSDM016GF5AN-PCW
32GB	APSDM032GF5AN-PC	APSDM032GF5AN-PCW

7P/270D MP: Power Cable-less Type

Capacity	Standard	Extended Temperature
2GB	APSDM002GF5AN-PTC	APSDM002GF5AN-PTWC
4GB	APSDM004GF5AN-PTC	APSDM004GF5AN-PTWC
8GB	APSDM008GF5AN-PTC	APSDM008GF5AN-PTWC
16GB	APSDM016GF5AN-PCC	APSDM016GF5AN-PCWC
32GB	APSDM032GF5AN-PCC	APSDM032GF5AN-PCWC

7P/270D MP: Power Cable Type with write protect

Capacity	Standard	Extended Temperature
2GB	APSDM002GF5PN-PT	APSDM002GF5PN-PTW
4GB	APSDM004GF5PN-PT	APSDM004GF5PN-PTW
8GB	APSDM008GF5PN-PT	APSDM008GF5PN-PTW
16GB	APSDM016GF5PN-PC	APSDM016GF5PN-PCW
32GB	APSDM032GF5PN-PC	APSDM032GF5PN-PCW

7P/270D MP: Power Cable-less Type

Capacity	Standard	Extended Temperature
2GB	APSDM002GF5PN-PTC	APSDM002GF5PN-PTWC
4GB	APSDM004GF5PN-PTC	APSDM004GF5PN-PTWC
8GB	APSDM008GF5PN-PTC	APSDM008GF5PN-PTWC
16GB	APSDM016GF5PN-PCC	APSDM016GF5PN-PCWC
32GB	APSDM032GF5PN-PCC	APSDM032GF5PN-PCWC

Note: Please consult with Apacer sales representatives for availabilities.

Revision History

Revision	Date	Description	Remark
0.1	11/25/2011	Preliminary release	
1.0	12/02/2011	Official release	
1.1	1/19/2012	Revised Capacity Specifications	
1.2	11/16/2012	Updated Product Ordering Information due to firmware change	
1.3	07/05/2013	Updated Product Ordering Information due to firmware change	

Global Presence

Taiwan (Headquarters)	Apacer Technology Inc. 4 th Fl., 75 Hsin Tai Wu Rd., Sec.1 Xizhi, New Taipei City Taiwan 221 R.O.C. Tel: +886-2-2698-2888 Fax: +886-2-2698-2889 amtsales@apacer.com
U.S.A.	Apacer Memory America, Inc. 386 Fairview Way, Suite102, Milpitas, CA 95035 Tel: 1-408-518-8699 Fax: 1-408-935-9611 sa@apacerus.com
Japan	Apacer Technology Corp. 5F, Matsura Bldg., Shiba, Minato-Ku Tokyo, 105-0014, Japan Tel: 81-3-5419-2668 Fax: 81-3-5419-0018 jpservices@apacer.com
Europe	Apacer Technology B.V. Science Park Eindhoven 5051 5692 EB Son, The Netherlands Tel: 31-40-267-0000 Fax: 31-40-267-0000#6199 sales@apacer.nl
China	Apacer Electronic (Shanghai) Co., Ltd 1301, No.251,Xiaomujiao Road, Shanghai, 200032, China Tel: 86-21-5529-0222 Fax: 86-21-5206-6939 sales@apacer.com.cn
India	Apacer Technologies Pvt Ltd, # 535, 1st Floor, 8th cross, JP Nagar 3rd Phase, Bangalore – 560078, India Tel: 91-80-4152-9061 sales_india@apacer.com