



Getting Started with the ARMIC30 Evaluation Board (ARM Core-based Industrial Controller using STR730 MCU)

Introduction

This user manual describes the implementation of the ARMIC30 Evaluation Board. The ARMIC30 can be used to evaluate a variety of devices, especially microcontrollers, with the added advantage that all pins are available on logically structured and well-documented header pins.

Applications are based on 32-bit STR730F microcontroller that uses a powerful ARM7TDMI core providing an extensive range of peripheral functions and enhanced I/O capabilities. The ARMIC30 is equipped with RS-232, RS-485, CAN, SPI, I²C and JTAG communication interfaces.

The evaluation board also includes digital input/output connectors and three motor control connectors with a pinout compatible with PowerSpin evaluation boards (supporting L6205, -6, -7, -8, and L6235 integrated motor drivers). The output interface is compatible with VN808 and VN340 Reference Design Boards and the input interface can be used for CLT3-4BT6 or PCLT-2A evaluation board connections.

Applications can be supplied from a standard DC power supply (7 to 30V DC) or directly using a 24V DC industrial mains supply.

Complete solution is implemented on double-face board with only two copper layers for increased cost-effectiveness. Routing accuracy is also cost-optimized.

The ARMIC30 evaluation board package includes a CD-ROM containing the standard STR730 software library, source code examples, board fabrication data (Gerber files), this user manual and other related documentation.

Key Features

- 32-bit STR730FZ2T7 microcontroller with 36-MHz ARM7TDMI CPU core
- RS-232 interface with 15kV guaranteed ESD protection using ST202E transceiver
- RS-485 interface using ST485A high-speed transceiver with bit rates up to 30 Mbps
- L9616 high-speed CAN driver with communication speeds up to 1 Mbps
- SPI and I²C communication connectors
- 8-bit digital input/output connectors
- 3 Motor Control connectors
- STM811 small reset circuit
- Power supply using L5973AD DC/DC converter
- 6 to 30V DC supply voltage range

Contents

- 1 Hardware 3**
 - 1.1 RS-232 interface 4
 - 1.2 RS-485 interface 5
 - 1.3 CAN interface 6
 - 1.4 SPI interface 7
 - 1.5 I²C interface 8
 - 1.6 JTAG interface 8
 - 1.6.1 JTAG supply voltages 9
 - 1.7 General purpose connectors 10
 - 1.7.1 General purpose input connector 10
 - 1.7.2 General purpose output connector 11
 - 1.7.3 General purpose motor control connectors 12
 - 1.8 LED indicators 13
 - 1.9 Power supplies 14
 - 1.10 Timing 15
 - 1.11 Reset 15
 - 1.12 Boot mode selection 16
- 2 Software 17**
- 3 Electrical specifications and timings 18**
- 4 Ordering information 19**
- Appendix A ARMIC30 board layout..... 20**
- Appendix B ARMIC30 schematic diagrams 24**
- Appendix C Jumper settings 29**
- Appendix D Bill of materials 31**
- Revision history 34**

1 Hardware

The ARMIC30 Evaluation Board is designed to evaluate and develop Industrial Controller (IC) applications that use several different communication interfaces as shown in [Figure 1](#).

Figure 1. ARMIC30 Communication interfaces

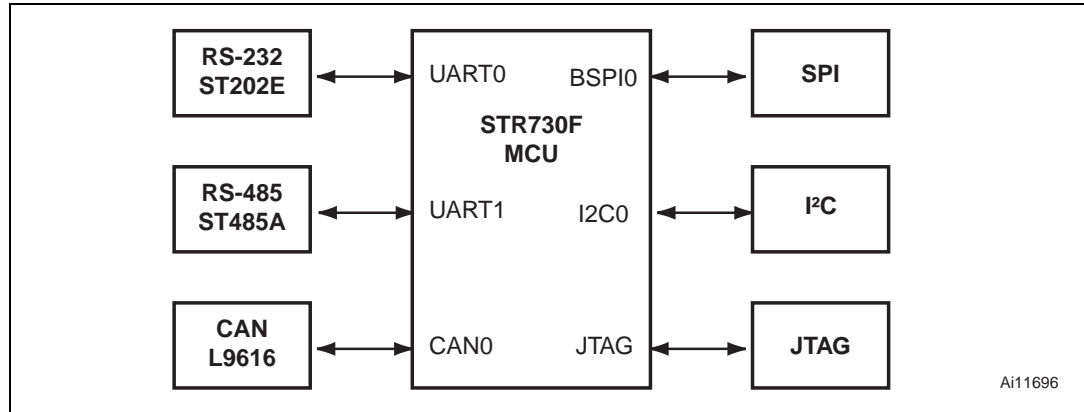

The ARMIC30 comes on a double-face printed circuit board with only two copper layers. Circuit routing is Class 5 accuracy meaning that the smallest route/isolation distance is 8 mil (0.2032 mm) and the smallest hole diameter is 20 mil (0.5080 mm). Board dimensions are 132 x 116 mm.

Figure 2. ARMIC30 board presentation

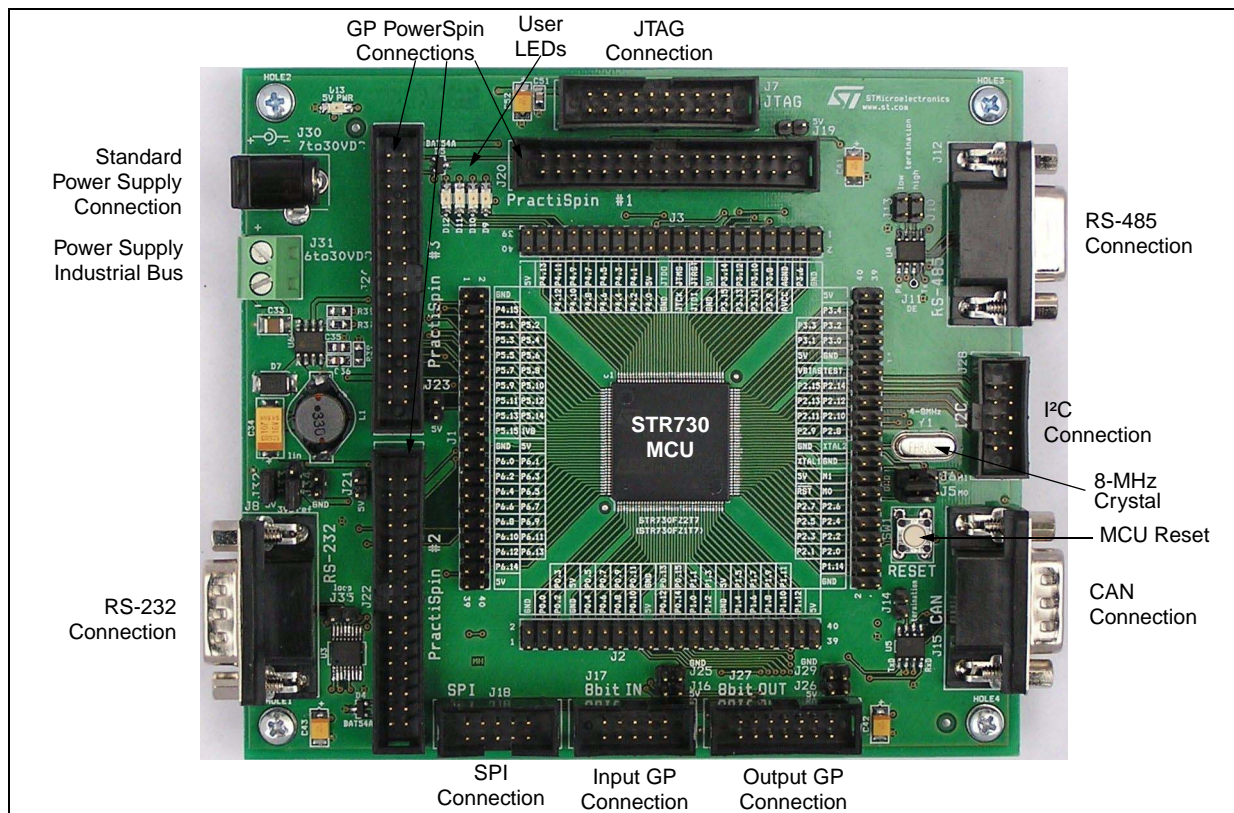

1.1 RS-232 interface

The ST202E Transceiver ensures RS-232 communication through the UART0 serial channel of the STR730F microcontroller as shown in [Figure 4](#).

The maximum speed of this interface is 230 Kbps.

The UART0 channel can be used for simple communication and internal Flash memory programming (for example, when using the RFLASHER application from Raisonance).

A male, 9-pin D-Sub connector (J8) provides the RS-232 connection. For correct interconnection with a PC, a “null-modem” cable (crossed Rx | Tx signals) should be used.

Jumper 35 can be used to select Loop mode (for testing purposes) as described in [Appendix C: Jumper settings](#).

Figure 3. RS-232 (J8), RS-485 (J12) and CAN (J15) connector pinout

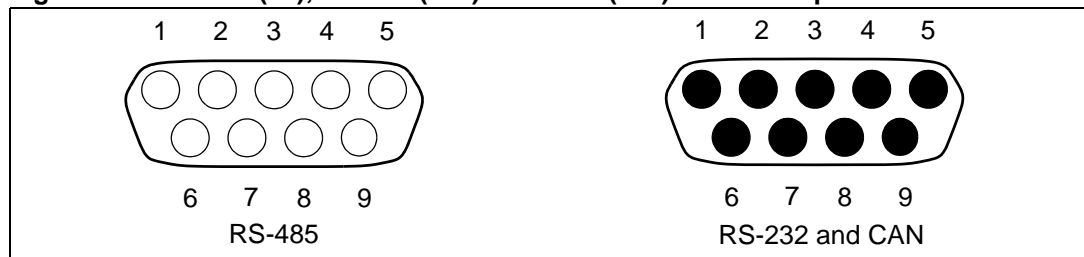
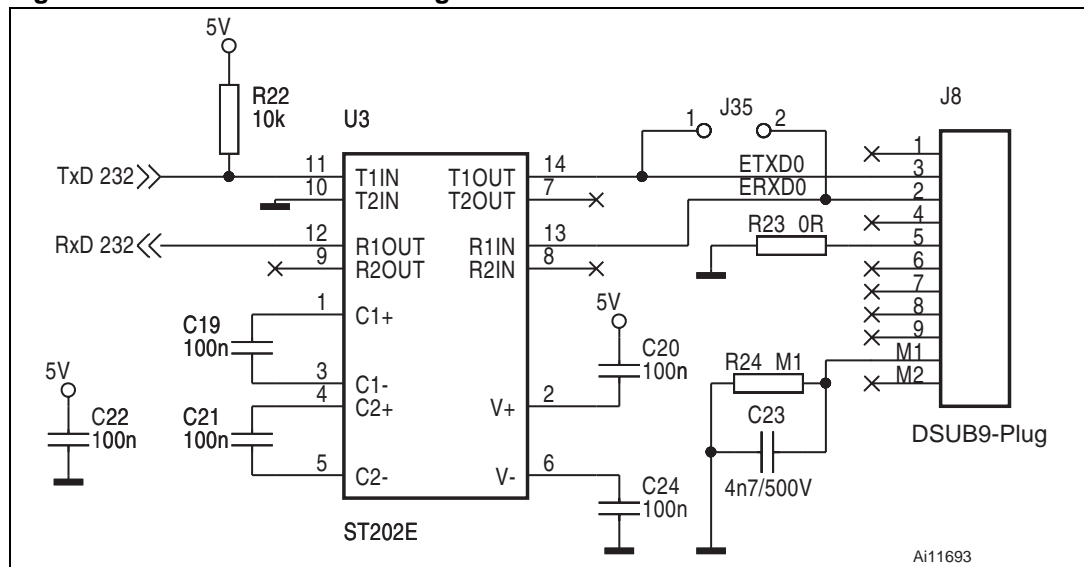

Table 1. RS-232 Connections

J8 Pin	Signal	STR730F MCU	Peripheral
2	RxD (Receive Data)	Port 6.8	UART0
3	TxD (Transmit Data)	Port 6.9	UART0
5	GND		
1, 4, 6 to 9	Not connected		
Shielding	Connected to GND by R24 C23 (100 kΩ 4.7 nF)		

Figure 4. RS-232 schematic diagram



1.2 RS-485 interface

The ST485A Transceiver ensures RS-485 communication through the UART1 serial channel of the STR730F microcontroller as shown in [Figure 5](#).

The maximum speed of this interface is greater than 30 Mbps.

A female, 9-pin D-Sub connector (J12) provides the RS-485 connection using a standard Profibus pinout.

The RS-485 channel can be terminated using jumpers J10 and J13 as described in [Appendix C: Jumper settings](#). Terminating resistors R25, R26 and R28 are selected for a Type-A Profibus DP cable as shown in [Figure 5](#). These resistors can be replaced with different values depending on the physical layer implemented.

Table 2. RS-485 Connections

J12 Pin	Signal	STR730F MCU	Peripheral
	RxD (Receive Data)	Port 2.9	UART1
	TxD (Transmit Data)	Port 2.8	UART1
	DE (Driver Enable)	Port 2.10	UART1
5	GND		
1, 2, 4, 7 and 9	Not connected		
Shielding	Connected to GND by R31 C26 (100 kΩ 4.7 nF)		

Figure 5. RS-485 schematic diagram

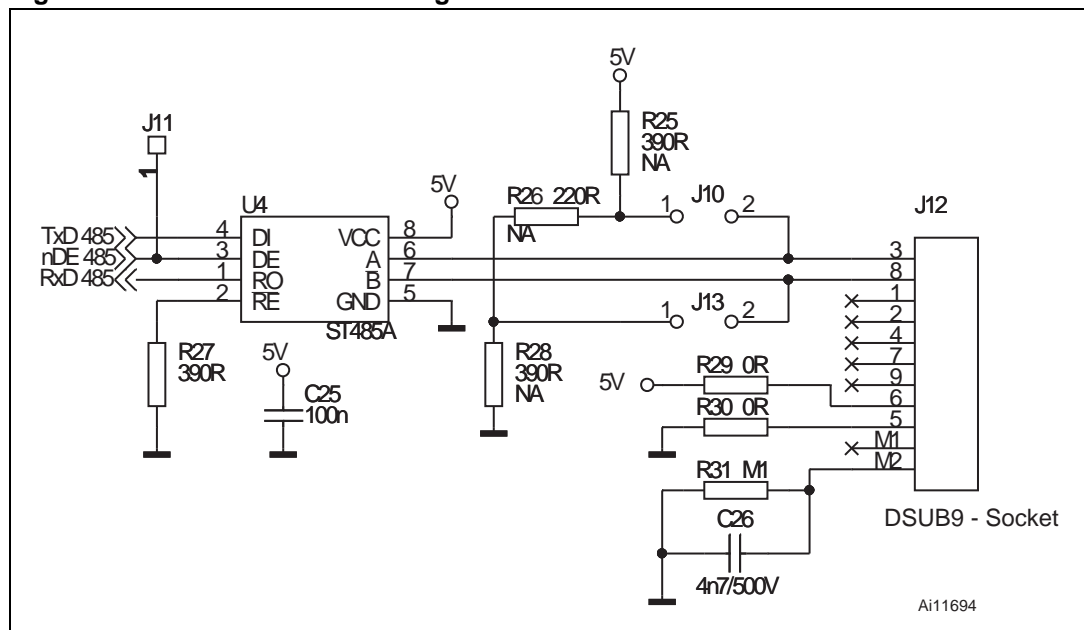

1.3 CAN interface

The L9616 High-Speed Transceiver provides the Controller Area Network (CAN) communication interface through the CAN0 channel of the STR730F microcontroller.

This serial communication can reach speeds up to 1Mbps.

A male, 9-pin D-Sub connector (J15) provides the CAN connection. The CAN channel can be terminated with a 120Ω resistor using jumper J14 as described in [Appendix C: Jumper settings](#). The L9616 CAN transceiver has an Adjustable Slope Control (ASC) feature that sets the slope speed using its ASC pin. This pin can be either hard-connected high or low using zero-ohm resistors or it can be controlled by MCU Port 2.0 as shown in [Figure 6](#).

[Table 4](#) describes the resistor assembly and control pin signal levels for CAN communications.

Table 3. CAN Connections

J15 Pin	Signal	STR730F MCU	Peripheral
	RxD (Receive Data)	Port 1.14	CAN0
	TxD (Transmit Data)	Port 1.15	CAN0
	ASC (Adjustable Slope Control)	Port 2.0	CAN0
2	CAN Low differential data		
7	CAN High differential data		
3	Shorted to 6. Connected to GND by R35 / 0Ω		
6	Shorted to 3. Connected to GND by R35 / 0Ω		
1, 4, 5, 8 and 9	Not connected		
Shielding	Connected to GND by R36 C28 (100 kΩ 4.7 nF)		

Figure 6. CAN schematic diagram

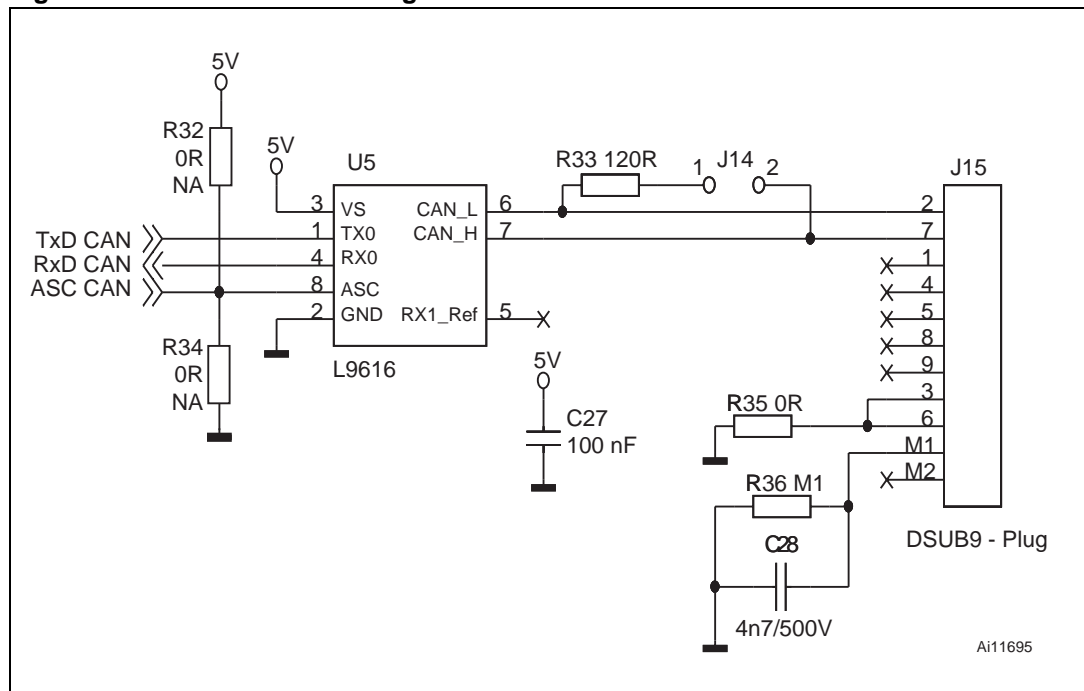

Table 4. CAN slew rate settings

Speed	Slew Rate (V/μs)	MCU Signal	Signal Level	Resistor
Low	5 to 20	P2.0	High	R32
High	20 to 50		Low	R34

- Note:
- 1 If using a resistor assembly (hardware option), the correct MCU signal must be set as an input!
 - 2 Do not assemble both resistors as this will short-circuit the supply voltage!

1.4 SPI interface

A 10-pin connector (J18) provides the Serial Peripheral Interface (SPI) through the BSPI0 channel of the STR730F microcontroller as shown in [Figure 7](#).

Connector J18 also provides additional general purpose signals that are primarily used as Watchdog (WD) and Slave Chip Select (SSn) lines.

Figure 7. SPI connector pinout

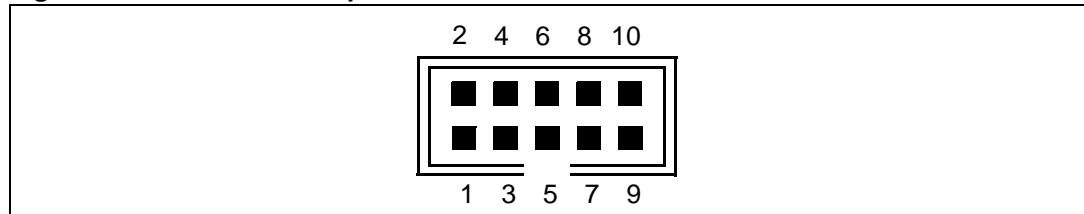

Table 5. SPI Connections

J18 Pin	Signal	STR730F MCU	Peripheral
1	GND		
2	+5V DC		
3	MOSI (Master Output/Slave Input)	Port 6.12	BSPI0
4	MISO (Master Input/Slave Output)	Port 6.11	BSPI0
5	SCK (Serial Clock)	Port 6.13	BSPI0
6	WD	Port 0.12	GPIO
7	$\overline{SS0}$ (Slave Select 0)	Port 6.14	BSPI0
8	$\overline{SS1}$ (Slave Select 1)	Port 0.13	GPIO
9	$\overline{SS2}$ (Slave Select 2)	Port 1.12	GPIO
10	$\overline{SS3}$ (Slave Select 3)	Port 1.13	GPIO

1.5 I²C interface

A 10-pin connector (J28) provides the Inter-Integrated Circuit (I²C) through the I2C0 channel of the STR730F microcontroller as shown in [Figure 8](#).

Connector J28 also provides additional general purpose signals (GP0, GP1 and GP2).

Figure 8. I²C connector pinout

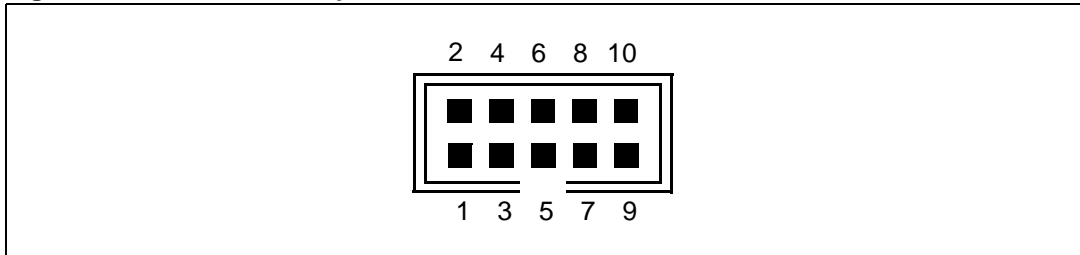

Table 6. I²C Connections

J28 Pin	Signal	STR730F MCU	Peripheral
1	GND		
2	+5V DC		
3	SDA (Serial Data)	Port 2.15	I2C0
4	Not connected		
5	SCL (Serial Clock)	Port 2.14	I2C0
6	Not connected		
7	GP0	Port 3.2	GPIO
8	GP1	Port 3.1	GPIO
9	GP2	Port 3.0	GPIO
10	Not connected		

1.6 JTAG interface

A 20-pin connector (J7) provides the JTAG interface as shown in [Figure 9](#).

This interface is primarily used for communicating with a PC using suitable converter box such as J-Link from IAR Systems or R-Link from Raisonance, etc. There exists a wide choice of development tools on the market supporting microcontroller Flash memory programming and application debugging.

Figure 9. JTAG connector pinout

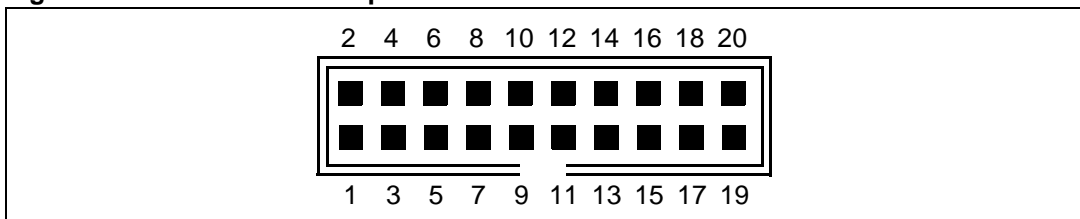
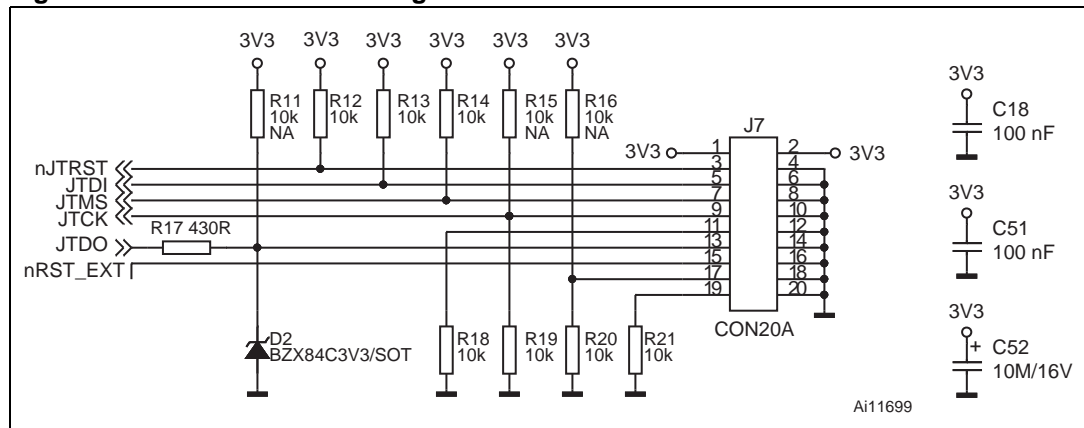

Table 7. JTAG connections

Pin	Signal	Pin	Signal
1	+3.3V DC	2	+3.3V DC
3	JTRST	4	GND
5	JTDI	6	GND
7	JTMS	8	GND
9	JTCK	10	GND
11	Connected to GND by R18 (10kΩ)	12	GND
13	JTDO	14	GND
15	RESET	16	GND
17	Connected to GND by R20 (10kΩ)	18	GND
19	Connected to GND by R21 (10kΩ)	20	GND

Figure 10. JTAG schematic diagram



1.6.1 JTAG supply voltages

A +3.3V DC supply voltage placed on pins 1 and 2 is provided by the DC/DC converter (U6) reference pin or a separate linear voltage regulator (U7). Please verify the consumption of any device (for example, converter box) connected to this connector. According to the device datasheet, the reference pin can deliver a maximum current of 5mA, providing an accurate voltage level. If the consumption is higher, select the linear voltage regulator (U7) for the supply connector using jumper J33 as described in [Appendix C: Jumper settings](#).

Certain converter boxes provide a +5V DC supply voltage for the JTAG interface. The new generation J-link from IAR Systems (the yellow one) provides the supply voltage on pin number 19. For applications using supplies from the converter box, connect a wire from pin number 19 of the JTAG (J7) connector to closest +5V DC supply point (for example, J19 right pin). For JTAG communication functions, jumper J32 must be connected and jumper J33 set to the "lin" position when a +5V DC voltage supply is used.

Caution: Using a supply from a converter box is not recommended for application development or testing. Accidental short-circuits may damage USB host or converter box circuits.

1.7 General purpose connectors

The ARMIC30 Evaluation Board provides two 8-bit general purpose I/O connectors (J17 and J27) and three general purpose motor control connectors (J20, J22 and J24) that can be used with current or future extension modules included in STMicroelectronics' offer (VN340 / VN808 / VN808CM Reference design boards, CLT3-4BT6 / PCLT-2A test boards, PowerSpin family of motor control drivers evaluation boards, etc.) or other applications developed by customers.

1.7.1 General purpose input connector

Jumpers J16 and J25 configure the supply voltage for the 8-bit input connector as described in [Appendix C: Jumper settings](#). The GP input connector is compatible with Current Limited Termination (CLT) and Programmable Current Limited Termination (PCLT) applications.

Figure 11. GPIO input connector pinout

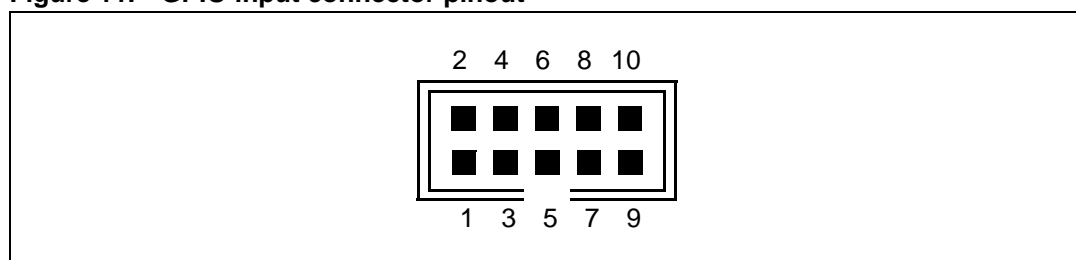

Table 8. 8-bit Input GPIO Connections

J17 Pin	Signal	STR730F MCU	Peripheral
1	+5V DC connected by jumper J16		
2	GND connected by jumper J25		
3	D7	Port 0.7	GPIO
4	D6	Port 0.6	GPIO
5	D5	Port 0.5	GPIO
6	D4	Port 0.4	GPIO
7	D3	Port 0.3	GPIO
8	D2	Port 0.2	GPIO
9	D1	Port 0.1	GPIO
10	D0	Port 0.0	GPIO

1.7.2 General purpose output connector

Jumpers J26 and J29 configure the supply voltage for the 8-bit output connector as described in [Appendix C: Jumper settings](#). The GP output connector is compatible with VN808 and VN340 Evaluation Boards.

Figure 12. GPIO output connector pinout

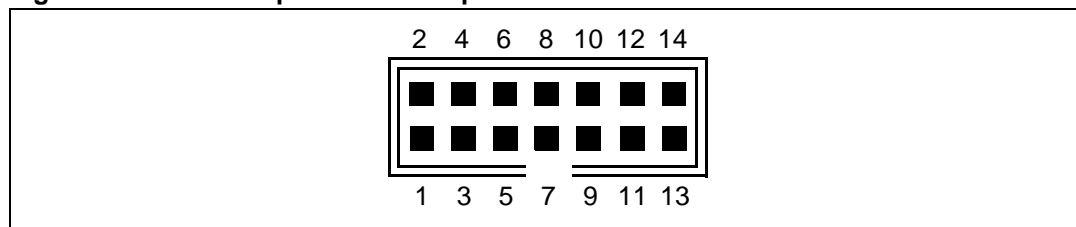

Table 9. J27 8-bit Output GPIO connections

J27 Pin	Signal	STR730F MCU	Peripheral
1	+5V DC connected by jumper J26		
2	GND connected by jumper J29		
3	STATUS0	Port 1.11	GPIO
4	D7	Port 1.7	GPIO
5	D6	Port 1.6	GPIO
6	D5	Port 1.5	GPIO
7	D4	Port 1.4	GPIO
8	D3	Port 1.3	GPIO
9	D2	Port 1.2	GPIO
10	D1	Port 1.1	GPIO
11	D0	Port 1.0	GPIO
12	STATUS3	Port 1.8	GPIO
13	STATUS2	Port 1.9	GPIO
14	STATUS1	Port 1.10	GPIO

1.7.3 General purpose motor control connectors

Jumpers J19, J21 and J23 configure the supply voltages for the J20, J22 and J24 motor control connectors, respectively, as described in [Appendix C: Jumper settings](#).

The GP Motor control connectors are compatible with the PowerSpin set of evaluation boards that are based on monolithic motor control chips. The PowerSpin chip family includes L6205 -6 -7 -8 and L6235 devices.

Figure 13. GPIO motor control connector pinout

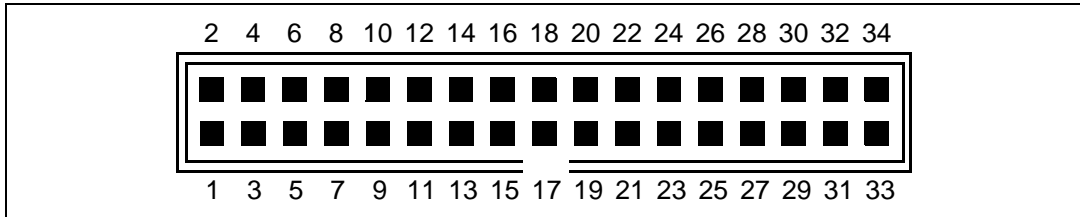

Table 10. 8-bit GPIO/Motor Control Connections

Pin No.	J20 MCU Connection	J22 MCU Connection	J24 MCU Connection	Periph.
1	+5V DC supply connected by Jumper J19	+5V DC supply connected by Jumper J21	+5V DC supply connected by Jumper J23	
2	P3.12 / INT2	P5.12 / INT10	P5.11 / INT9	INT
3	P3.10	P3.8	P3.6	AIN
4	P3.13 / INT3	P5.13 / INT11	P5.10 / INT8	INT
7	P3.11	P3.9	P3.7	AIN
8	P3.15 / INT5	P5.15 / INT13	P5.8 / INT6	INT
10	P4.0	P6.0	P5.7	GPIO
14	P4.1	P6.1	P5.6	GPIO
20	P4.2	P6.2	P5.5	GPIO
22	P0.9	P0.14	P0.11	OCMP
23	GND	GND	GND	
26	P3.14	P5.14	P5.9	INT
28	P0.8	P0.15	P0.10	OCMP
31	PWM5 cathode of diode D3 connected to GND	PWM1 cathode of diode D4 connected to GND	PWM3 cathode of diode D5 connected to GND	PWM
32	P1.8	P2.12	P2.13	INT
33	PWM4 cathode of diode D3 connected to GND	PWM0 cathode of diode D4 connected to GND	PWM2 cathode of diode D5 connected to GND	PWM
5, 6, 9, 11-13, 15-19, 21, 24, 25, 27, 29, 30 and 34	Not connected	Not connected	Not connected	

1.8 LED indicators

The ARMIC30 Evaluation Board includes an LED (D13) indicating a the presence of the +5V DC supply voltage and four additional LEDs (D9, D10, D11 and D12). These four LEDs can be individually configured through the STR730F MCU as described in [Table 11](#).

Table 11. LED Connections

LED	STR730F MCU	Peripheral
D9	Port 4.9	GPIO
D10	Port 4.10	GPIO
D11	Port 4.11	GPIO
D12	Port 4.12	GPIO

Figure 14. LED schematic diagram

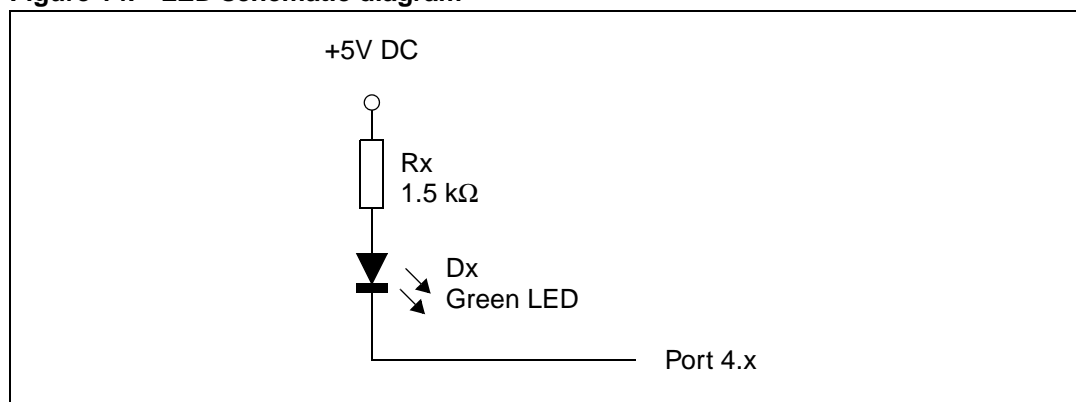

1.9 Power supplies

The L5973AD DC/DC converter (U6) supplies the ARMIC30 Evaluation Board with a +5V DC voltage supply using feedback resistors (R37 and R38) as shown in [Figure 15](#). A green LED (D13) lights up when this supply is present.

An additional +3.3V DC linear voltage regulator (U7) connected in cascade to the DC/DC converter output can be used to supply the JTAG connector and level converting resistors with a +3.3V DC supply voltage. Use jumper J33 to select either a DC/DC reference voltage or a linear regulator as described in [Section 1.6.1: JTAG supply voltages](#) and [Appendix C: Jumper settings](#).

Connectors J30 or J31 provide the ARMIC30 Evaluation Board power supplies. Connector J30 includes a polarity protection diode and is suitable for use with a standard mains adapter having an output voltage range between +7 and +30V DC. Connector J31 is connected directly to the DC/DC converter input which is over-voltage protected by a transil diode (D8) for a recommended supply voltage range between +6 and +30V DC. The ARMIC30 Evaluation Board clearly indicates the power supply polarity.

Figure 15. Power supply schematic diagram

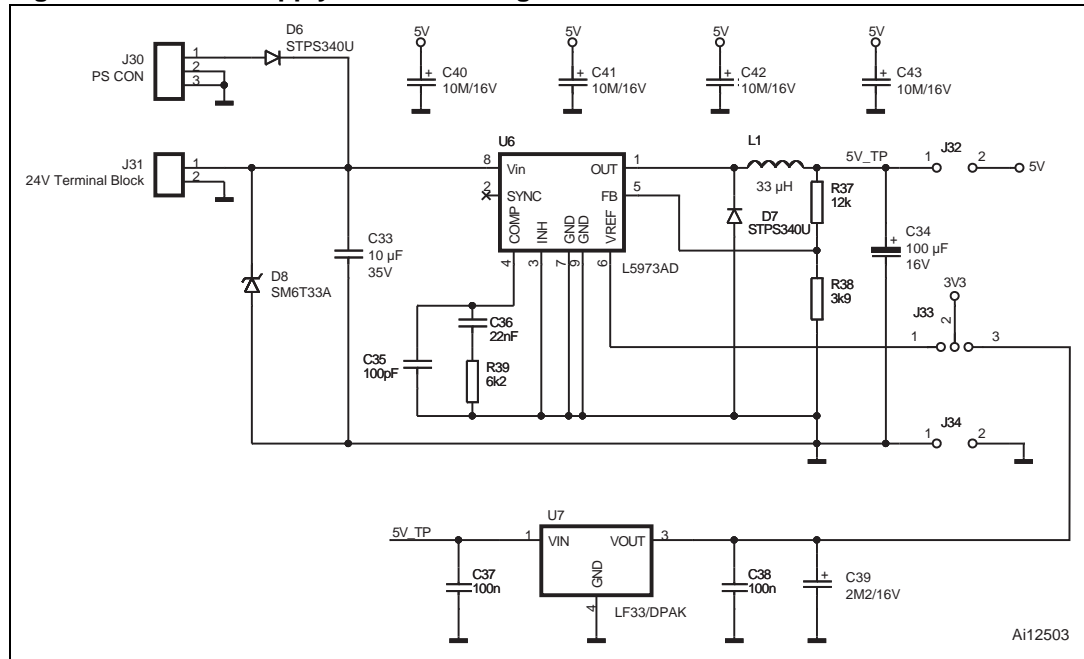

1.10 Timing

The ARMIC30 Evaluation Board uses a simple 8-MHz crystal assembly for timing as shown in [Figure 16](#).

Figure 16. Crystal assembly

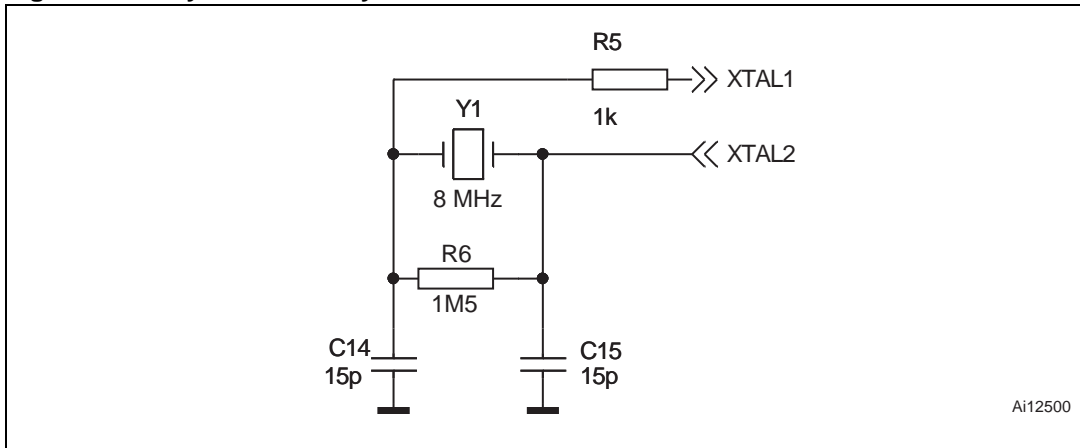

1.11 Reset

The ARMIC30 Evaluation Board includes a reset circuit used to reset the STR730 MCU using an STM811 Reset Circuit (U2) as shown in [Figure 17](#).

Figure 17. Reset circuit assembly

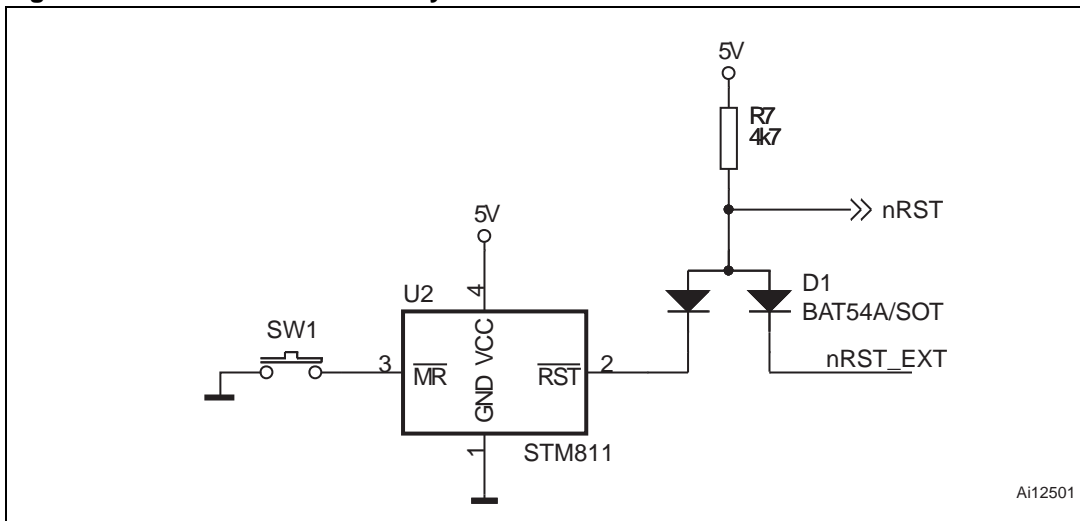

1.12 Boot mode selection

The ARMIC30 Evaluation Board includes a Boot mode selection circuit as shown in [Figure 18](#).

This feature selects boot memory access using Jumpers J5 and J6 as described in [Appendix C: Jumper settings](#).

For more information, please refer to the *STR730 Reference Manual*.

Figure 18. Boot mode selection circuit assembly

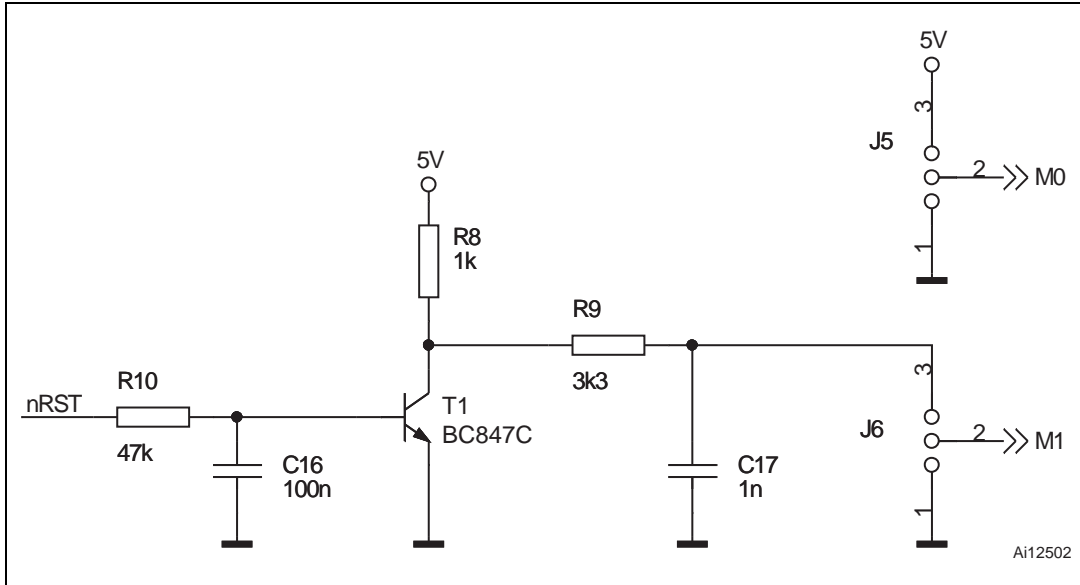

2 Software

The CD-ROM delivered with the ARMIC30 Evaluation Board contains several software examples demonstrating the use of microcontroller peripheral circuits. These examples use the standard STR730 software library which is available on www.st.com. Examples are created using the IAR Embedded Workbench for ARM development tools and appropriate project files are available on the CD-ROM.

The STR730 microcontroller is delivered pre-programmed with the “GPIO_ARMIC” example.

3 Electrical specifications and timings

Table 12. ARMIC30 evaluation board technical data

Parameter	Conditions	Min.	Typ.	Max.	Unit
Recommended board supply voltage range	From connector J30 From connector J31	7 6		30 30	V DC
Complete application power consumption ⁽¹⁾⁽²⁾	Run mode w/out Load, $V_S = 24V$ DC applied to J31, $f_{CPU} = 36$ MHz		26 624		mA mW

1. This value is not accurate and is for information only. MCU peripherals are not initialized and their pins supplied with static values. Program is running from internal Flash memory, working in an endless loop, performing only a branch instruction. All microcontroller peripherals are disabled, CMU is on and PLL is on.
2. Power consumption is measured with a 24V DC supply from J31 connector.

Table 13. ARMIC30 GPIO technical data

Parameter	Conditions	Min.	Typ.	Max.	Unit
Input Low Level		-0.3		0.8	V DC
Input High Level		2		5.3	
Output Low Level	Push Pull, $I_{OL} = 2mA$	0		0.4	V DC
Output High Level	Push Pull, $I_{OH} = 2mA$	4.2		5	

Table 14. ARMIC30 bus interface data

Parameter	Conditions	Min.	Typ.	Max.	Unit
RS-232 channel speed				230	Kbps
RS-485 channel speed				30	Mbps
CAN channel speed				1	Mbps

4 Ordering information

The ordering code for the ARMIC30 Evaluation Board is **STEVAL-IFN002V1**.

This includes CD-ROM with documentation, board fabrication data and software (see [Section 2: Software on page 17](#)).

Appendix A ARMIC30 board layout

This section describes the layout of ARMIC30 Evaluation Board PCB.

Figure 19. ARMIC30 top layer

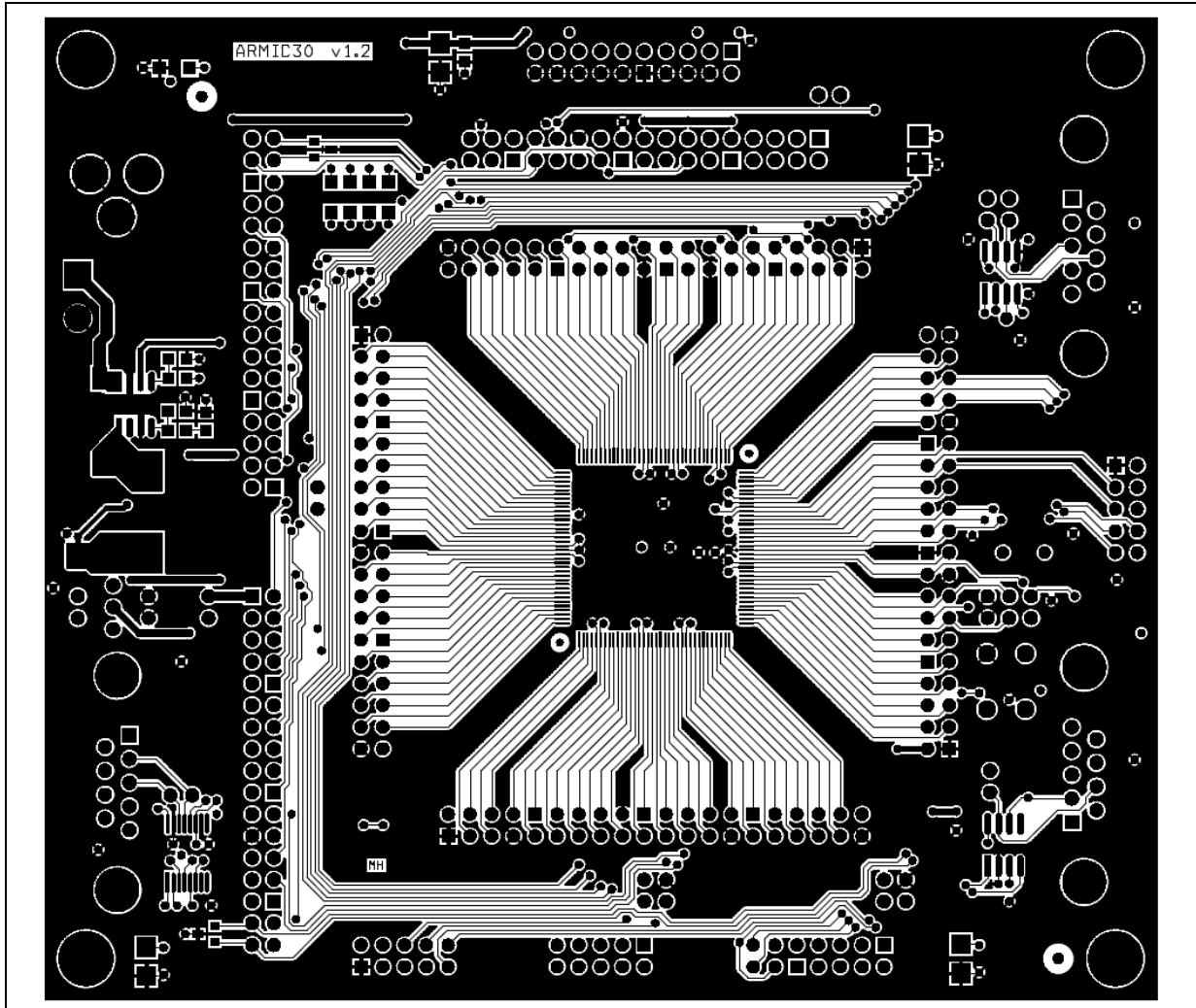

Figure 20. ARMIC30 bottom layer

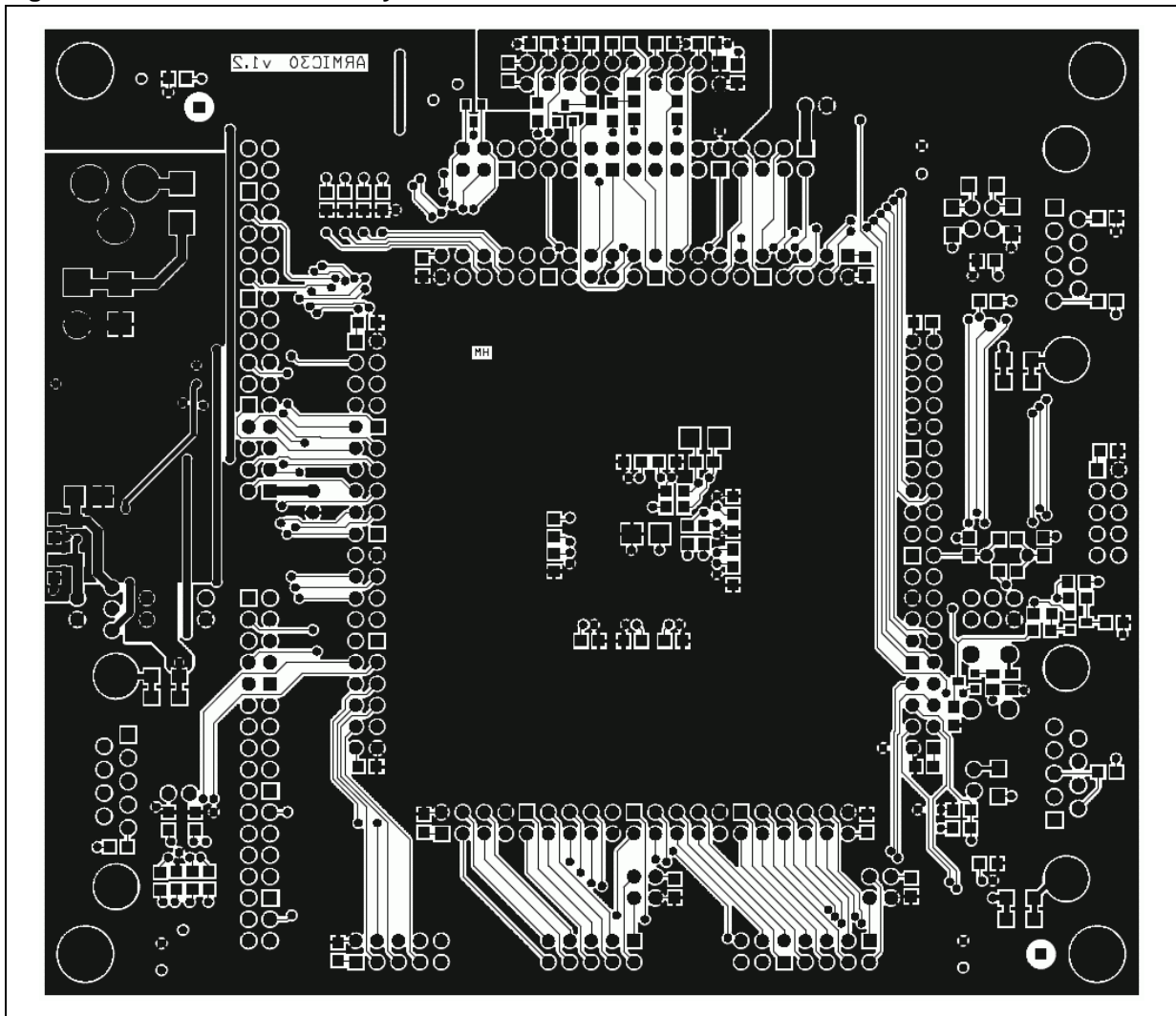

Figure 21. ARMIC30 silk screen top layer

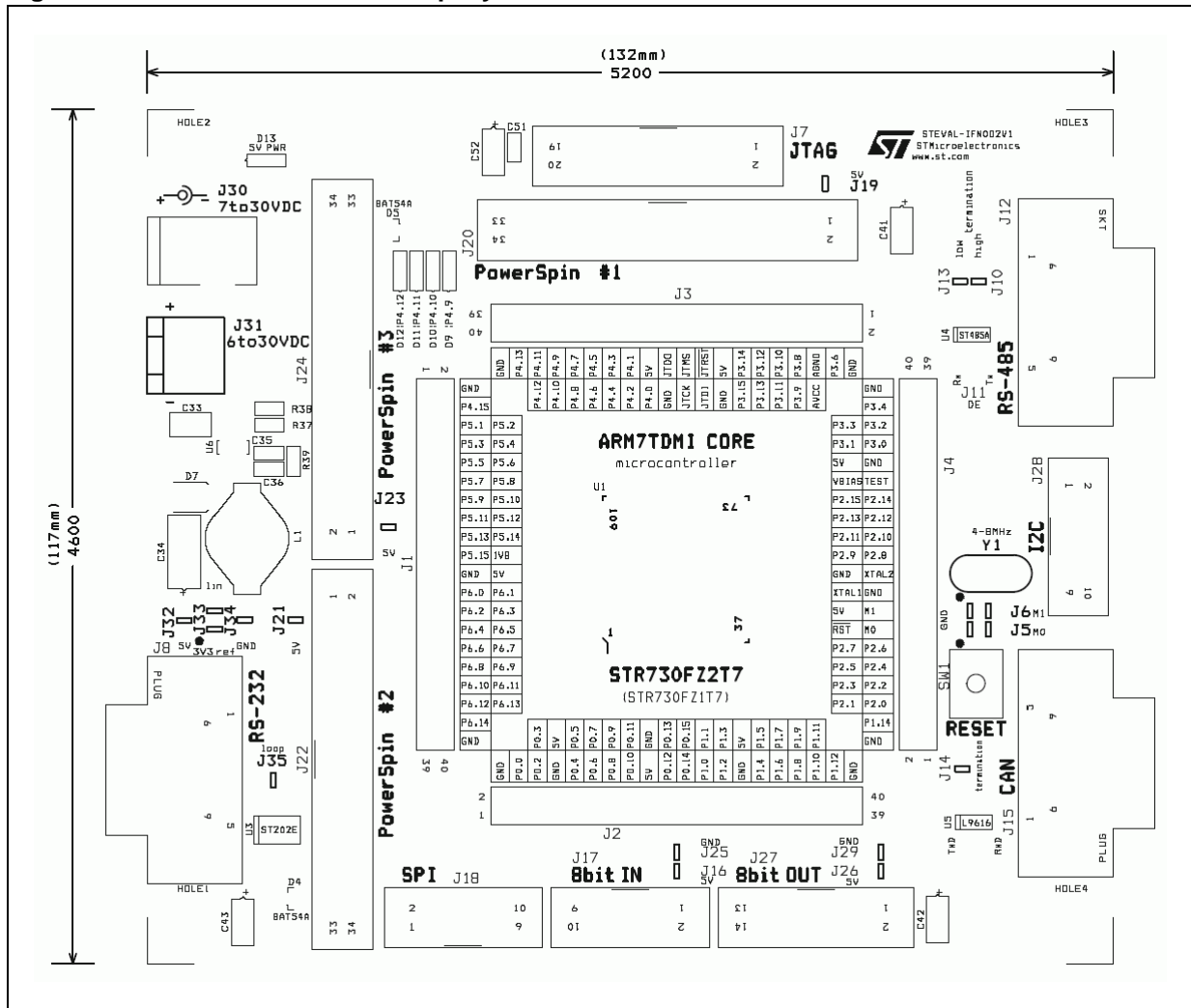

Figure 22. ARMIC30 silk screen bottom layer

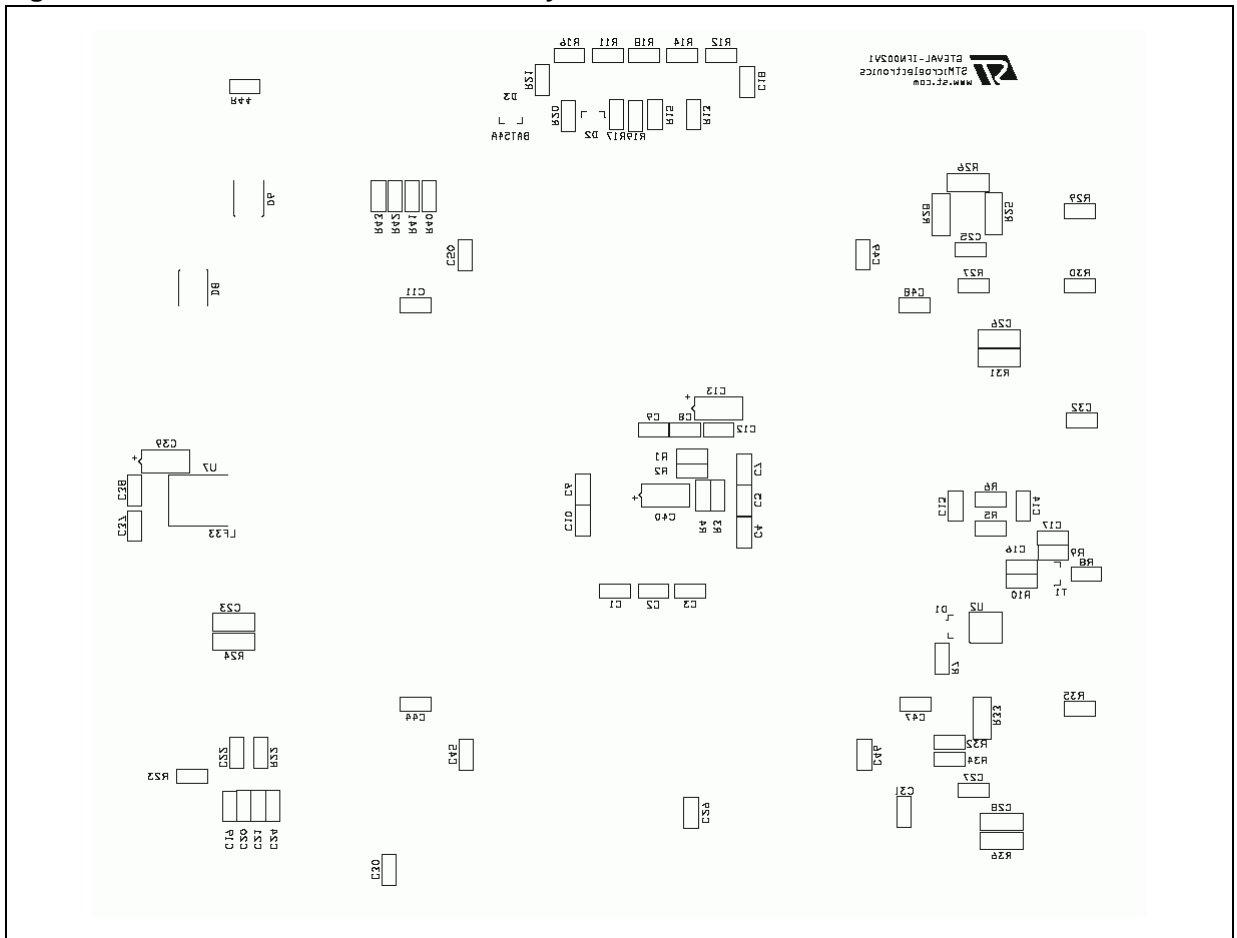

Figure 24. 8-bit input and output, SPI, I²C and MC connector schematics

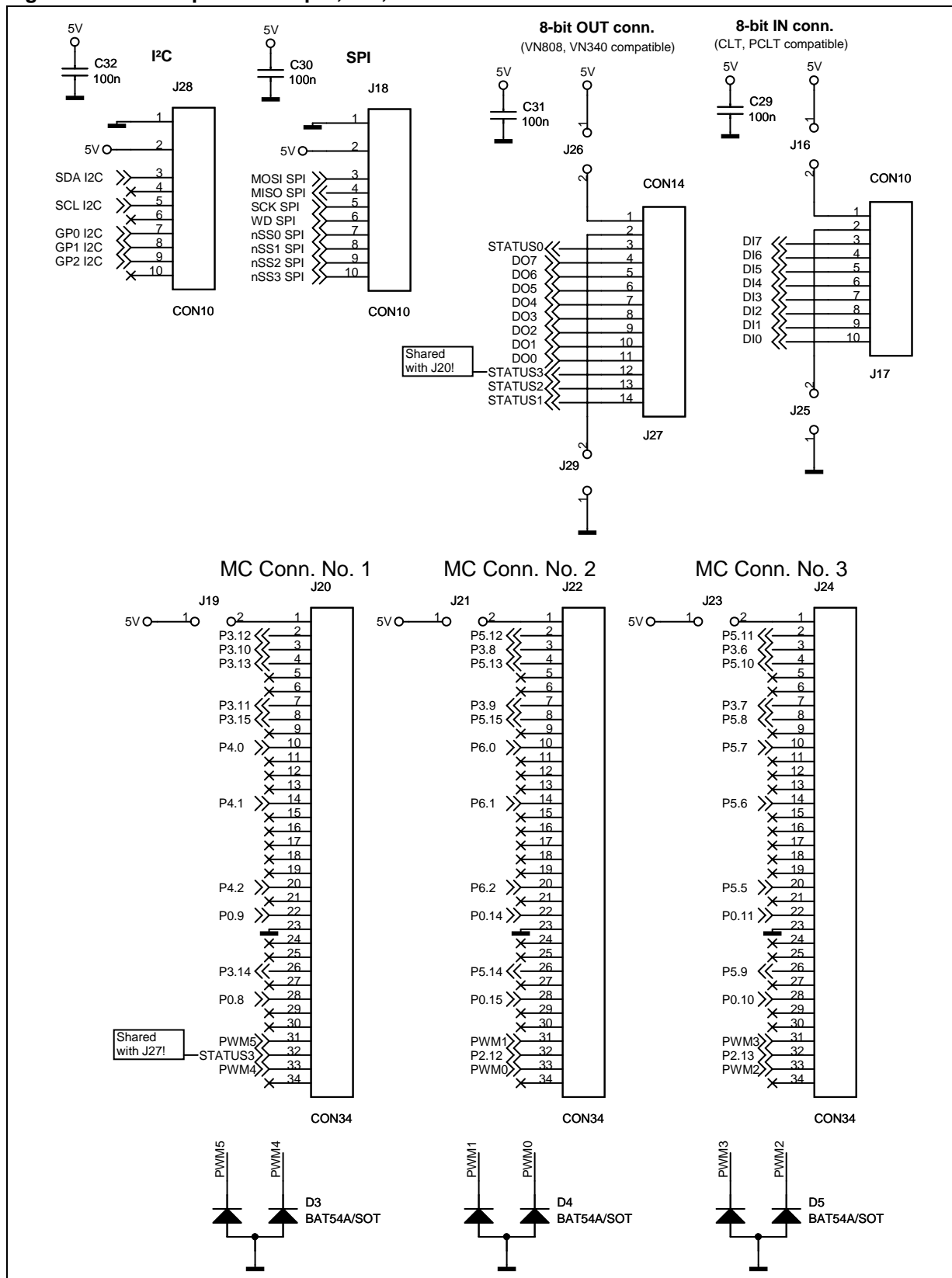

Figure 25. RS-232, RS-485 and CAN connector schematics

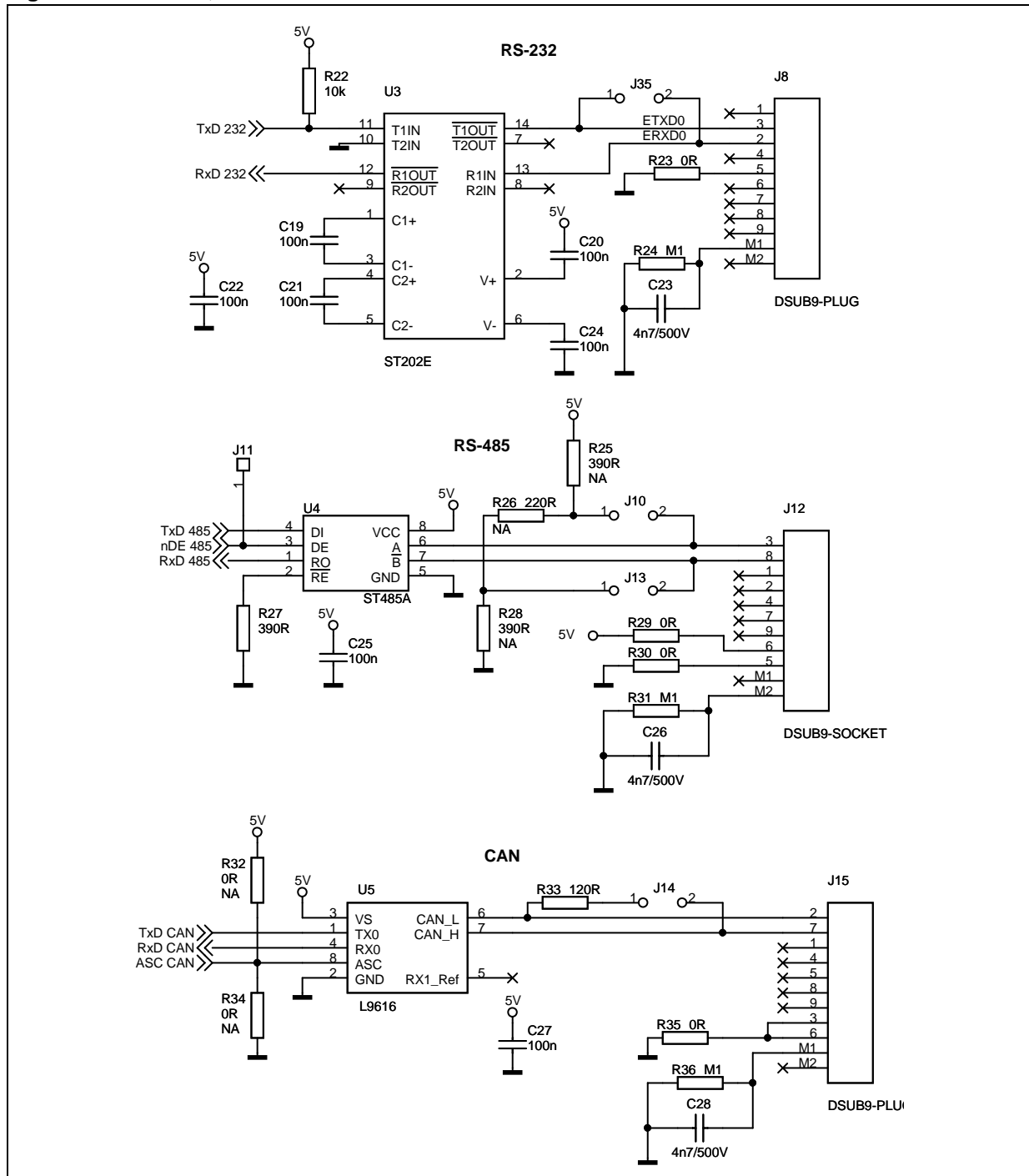

Figure 26. Reset, LED, Clock, Boot and JTAG circuit schematics

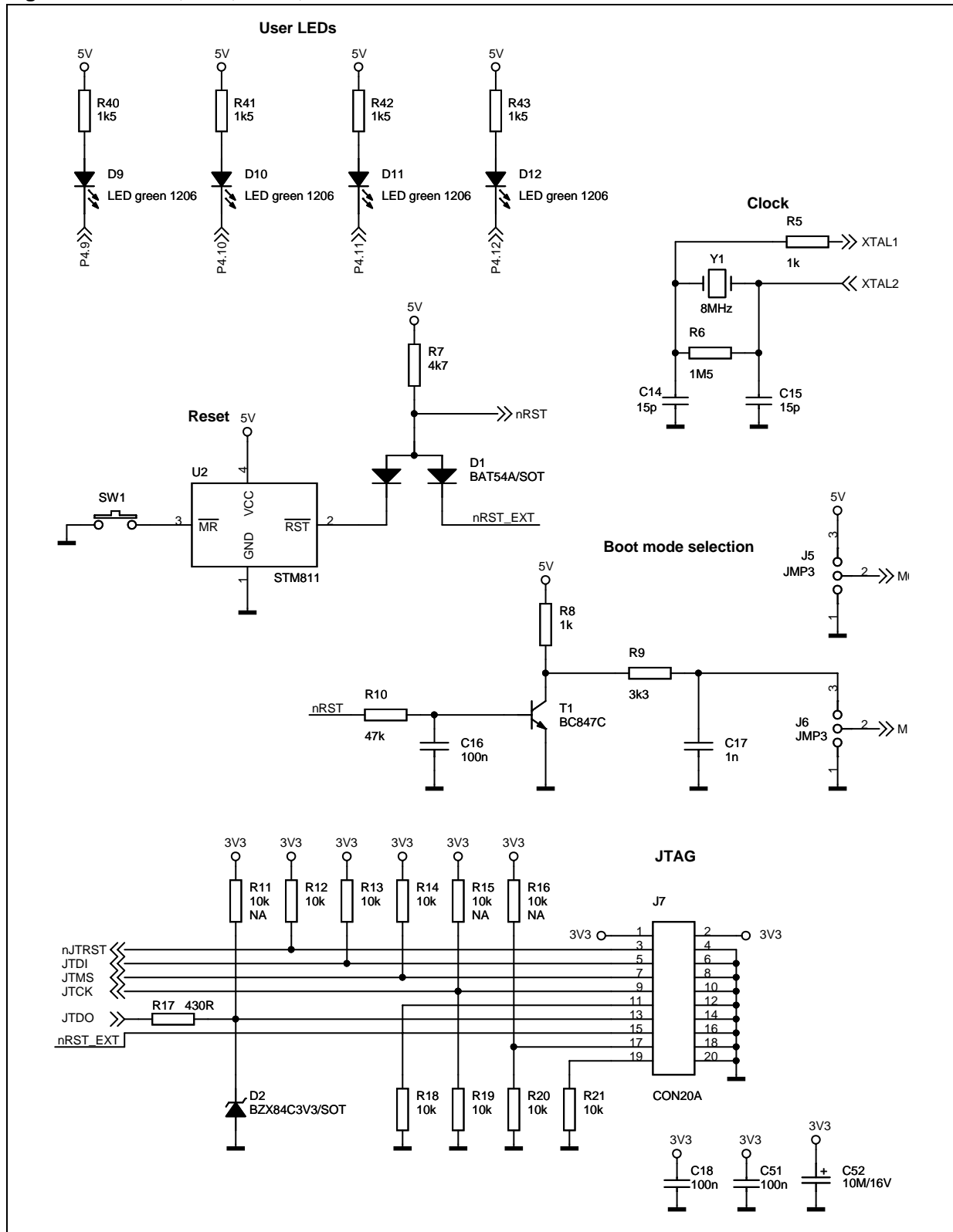
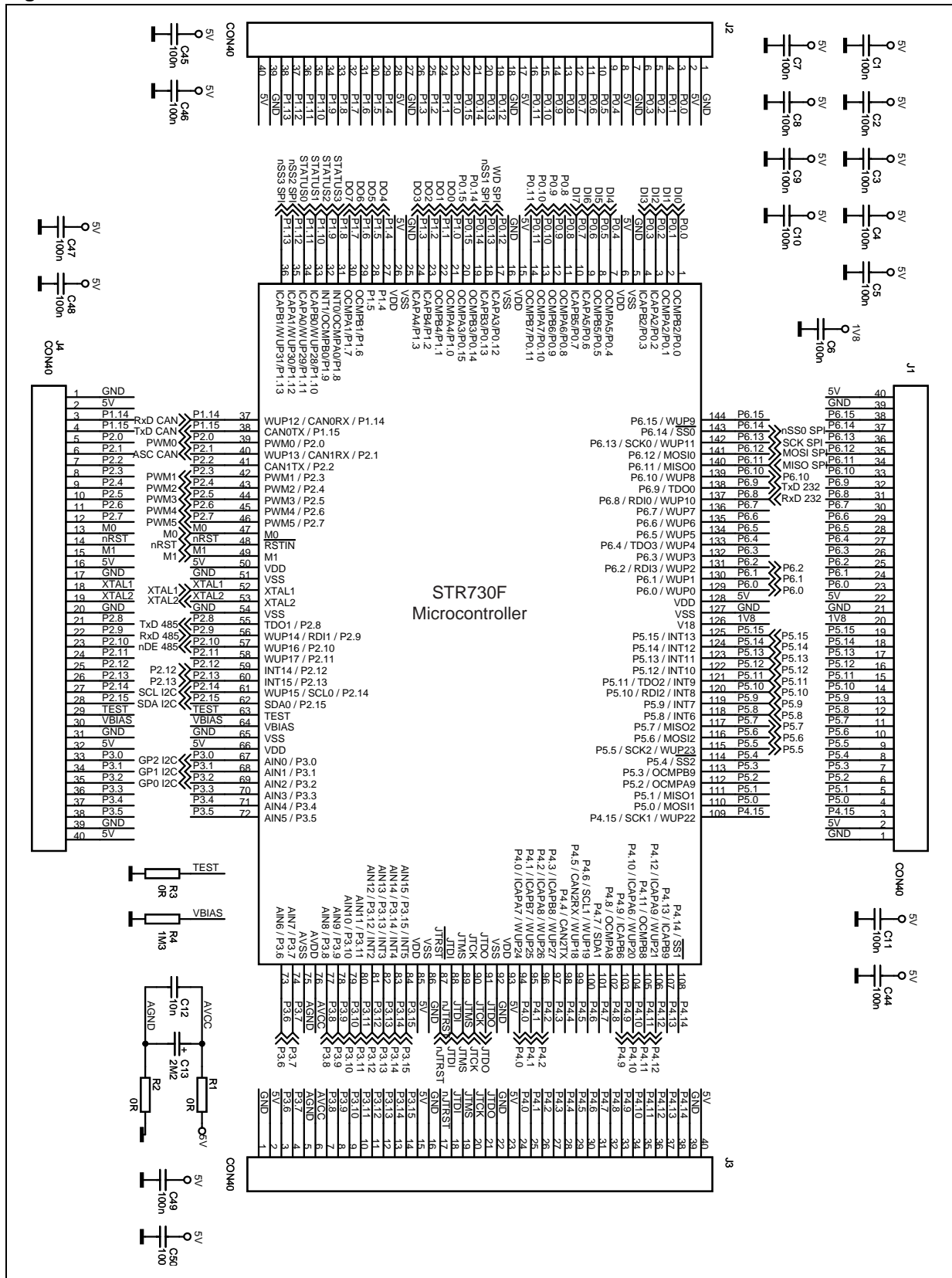

Figure 27. MCU schematic



Appendix C Jumper settings

[Table 15](#) describes the jumper settings for the ARMIC30 Evaluation Board.

Table 15. ARMIC30 jumper settings

Jumper	Function	Description
J32	+5V DC application voltage supply to DC/DC converter (U6)	When pins 1 and 2 are connected, the +5V DC voltage supply is connected. Otherwise, it is disconnected.
J33	+3.3V DC application part supplying connection to DC/DC converter (U6) reference pin or linear voltage regulator (U7)	When pins 1 and 2 are connected, the DC/DC converter (U6) reference pin supplies the 3.3V application part voltage. When pins 2 and 3 are connected, the linear voltage regulator (U7) supplies the 3.3V application part voltage.
J34	GND test point	Both sides are connected to GND.
J5	MCU Boot mode selection (M0 pin) ⁽¹⁾	When pins 1 and 2 are connected, the M0 pin is connected permanently to GND. When pins 2 and 3 are connected, the M0 pin is connected permanently to +5V DC.
J6	MCU Boot mode selection (M1 pin) ⁽¹⁾	When pins 1 and 2 are connected, the M1 pin is connected permanently to GND. When pins 2 and 3 are connected, the M1 pin is connected to +5V DC during a microcontroller reset. After a reset, it is tied to GND.
J35	RS-232 loop selection	When pins 1 and 2 are connected, the RS-232 is in Loop mode and the Rx and Tx lines are connected together (for hardware or software testing). Otherwise, the RS-232 connection is in Normal mode
J10 and J13	RS-485 bus termination	When pins 1 and 2 are connected, the RS-485 bus is terminated. (Node is at the end of the RS-485 bus.) ⁽²⁾ Otherwise, the RS-485 bus is unterminated.
J14	CAN channel termination	When pins 1 and 2 are connected, the CAN bus is terminated. ⁽³⁾ Otherwise, the CAN bus is unterminated.
J19, J21 and J23	+5V DC connection (to pin number 1 of corresponding general purpose / motor control connector)	When pins 1 and 2 are connected, the corresponding +5V DC supply is connected. Otherwise, it is disconnected.
J16	+5V DC connection to pin number 1 of the 8-bit Input/General Purpose connector (J17)	When pins 1 and 2 are connected, the +5V DC supply is connected. Otherwise, it is disconnected.

Table 15. ARMIC30 jumper settings (continued)

Jumper	Function	Description
J25	GND connection to pin number 2 of the 8-bit Input/General Purpose connector (J17)	When pins 1 and 2 are connected, the GND supply is connected. Otherwise, it is disconnected.
J26	+5V DC connection to pin number 1 of the 8-bit Output/General Purpose connector (J27)	When pins 1 and 2 are connected, the +5V DC supply is connected. Otherwise, it is disconnected.
J29	GND connection to pin number 2 of the 8-bit Output/General Purpose connector (J27)	When pins 1 and 2 are connected, the GND supply is connected. Otherwise, it is disconnected.

1. For detailed information about Boot Selection modes, please refer to STR730 Reference Manual.
2. Please check the termination resistors values (R25, R26 and R28) for your RS-485 physical layer.
3. CAN bus is terminated by resistor R33 (120Ω).

Appendix D Bill of materials

Table 16. Bill of materials

ID	Qty	Reference	Value	Type	Mftr/Dist	Order Code
1	34	C1, C2, C3, C4, C5, C6, C7, C8, C9, C10, C11, C16, C18, C19, C20, C21, C22, C24, C25, C27, C29, C30, C31, C32, C37, C38, C44, C45, C46, C47, C48, C49, C50 and C51	100nF ceramic	SMD 0805		
2	1	C12	10nF ceramic	SMD 0805		
3	2	C13 and C39	2.2uF/16V electrolytic tantalum	SMD B		
4	2	C14 and C15	15pF ceramic	SMD 0805		
5	1	C17	1nF ceramic	SMD 0805		
6	3	C23, C26 and C28	4.7nF/500V ceramic	SMD 1206		
7	1	C33	10uF/35V ceramic	SMD 1210	IN Electronics	KOND 1210 10uF 35V Y5V Taiyo
8	1	C34	100uF/16V electrolytic tantalum	SMD D		
9	1	C35	100pF ceramic	SMD 0805		
10	1	C36	22nF ceramic	SMD 0805		
11	5	C40, C41, C42, C43 and C52	10uF/16V electrolytic tantalum	SMD B		
12	4	D1, D3, D4 and D5	BAT54A	SMD SOT23	ST	BAT54AFILM
13	1	D2	BZX84C3V3	SMD SOT23		
14	2	D6 and D7	STPS340U	SMD DO214	ST	STPS340U
15	1	D8	SM6T33A	SMD DO214	ST	SM6T33A
16	5	D9, D10, D11, D12 and D13	LED - green 1206	SMD 1206		
17	4	J1, J2, J3 and J4	40-pin strip header - dual in line 2.54x2.54mm pitch	THT		
18	3	J5, J6 and J33	3-pin strip header - single in line 2.54mm pitch	THT		
19	1	J7	20-pin box header - dual in line with lock 2.54x2.54mm pitch	THT		
20	2	J8 and J15	9-pin D-Sub plug	THT		
21	13	J10, J13, J14, J16, J19, J21, J23, J25, J26, J29, J32, J34 and J35	2-pin strip header - single in line 2.54mm pitch	THT		

Table 16. Bill of materials (continued)

ID	Qty	Reference	Value	Type	Mftr/Dist	Order Code
22	1	J11	1 pin strip header - single in line 2.54mm pitch	Not Assembled, THT		
23	1	J12	9 pin D-Sub socket	THT		
24	3	J17, J18 and J28	10 pin box header - dual in line with lock 2.54x2.54mm pitch	THT		
25	3	J20, J22 and J24	34 pin box header - dual in line with lock 2.54x2.54mm pitch	THT		
26	1	J27	14 pin box header - dual in line with lock 2.54x2.54mm pitch	THT		
27	1	J30	2.1mm coaxial power supply connector	THT		
28	1	J31	2-pin terminal block with 5.08mm pitch	THT		
29	1	L1	33uH	SMD	Würth Elektronik	74456133
30	7	R1, R2, R3, R23, R29, R30 and R35	0Ω	SMD 0805		
31	2	R32 and R34	0Ω	Not Assembled, SMD 0805		
32	1	R4	1.3MΩ	SMD 0805		
33	2	R5 and R8	1kΩ	SMD 0805		
34	1	R6	1.5MΩ	SMD 0805		
35	1	R7	4.7kΩ	SMD 0805		
36	1	R9	3.3kΩ	SMD 0805		
37	1	R10	47kΩ	SMD 0805		
38	3	R11, R15 and R16	10kΩ	Not Assembled, SMD 0805		
39	8	R12, R13, R14, R18, R19, R20, R21 and R22	10kΩ	SMD 0805		
40	1	R17	430Ω	SMD 0805		
41	3	R24, R31 and R36	100kΩ	SMD 1206		
42	2	R25 and R28	390Ω	SMD 1206		
43	1	R26	220Ω	SMD 1206		
44	1	R27	390Ω	SMD 0805		

Table 16. Bill of materials (continued)

ID	Qty	Reference	Value	Type	Mfrt/Dist	Order Code
45	1	R33	120Ω	SMD 1206		
46	1	R37	12kΩ	SMD 0805		
47	1	R38	3.9kΩ	SMD 0805		
48	1	R39	6.2kΩ	SMD 0805		
49	5	R40, R41, R42, R43 and R44	1.5kΩ	SMD 0805		
50	1	SW1	Push-button switch	THT	Farnell	176-432
51	1	T1	BC847C	SMD SOT23		
52	1	U1	STR730F	SMD	ST	STR730FZ2T7
53	1	U2	STM811	SMD SOT143-4	ST	STM811LW16F
54	1	U3	RS-232 Transceiver	SMD	ST	ST202EBTR
55	1	U4	RS-485 Transceiver	SMD	ST	ST485ABDR
56	1	U5	High-Speed CAN Bus Transceiver	SMD	ST	L9616
57	1	U6	L5973AD	SMD	ST	L5973AD
58	1	U7	LF33	SMD DPAK	ST	LF33ABDT-TR
59	1	Y1	8-MHz crystal oscillator with 4.88mm pitch	THT		

Revision history

Table 17. Document revision history

Date	Revision	Changes
2-Feb-2006	1	Initial release.
21-Apr-2006	2	Changed crystal value from 6 MHz to 8 MHz.Updated MCU port assignment information.

Please Read Carefully:

Information in this document is provided solely in connection with ST products. STMicroelectronics NV and its subsidiaries ("ST") reserve the right to make changes, corrections, modifications or improvements, to this document, and the products and services described herein at any time, without notice.

All ST products are sold pursuant to ST's terms and conditions of sale.

Purchasers are solely responsible for the choice, selection and use of the ST products and services described herein, and ST assumes no liability whatsoever relating to the choice, selection or use of the ST products and services described herein.

No license, express or implied, by estoppel or otherwise, to any intellectual property rights is granted under this document. If any part of this document refers to any third party products or services it shall not be deemed a license grant by ST for the use of such third party products or services, or any intellectual property contained therein or considered as a warranty covering the use in any manner whatsoever of such third party products or services or any intellectual property contained therein.

UNLESS OTHERWISE SET FORTH IN ST'S TERMS AND CONDITIONS OF SALE ST DISCLAIMS ANY EXPRESS OR IMPLIED WARRANTY WITH RESPECT TO THE USE AND/OR SALE OF ST PRODUCTS INCLUDING WITHOUT LIMITATION IMPLIED WARRANTIES OF MERCHANTABILITY, FITNESS FOR A PARTICULAR PURPOSE (AND THEIR EQUIVALENTS UNDER THE LAWS OF ANY JURISDICTION), OR INFRINGEMENT OF ANY PATENT, COPYRIGHT OR OTHER INTELLECTUAL PROPERTY RIGHT.

UNLESS EXPRESSLY APPROVED IN WRITING BY AN AUTHORIZED REPRESENTATIVE OF ST, ST PRODUCTS ARE NOT DESIGNED, AUTHORIZED OR WARRANTED FOR USE IN MILITARY, AIR CRAFT, SPACE, LIFE SAVING, OR LIFE SUSTAINING APPLICATIONS, NOR IN PRODUCTS OR SYSTEMS, WHERE FAILURE OR MALFUNCTION MAY RESULT IN PERSONAL INJURY, DEATH, OR SEVERE PROPERTY OR ENVIRONMENTAL DAMAGE.

Resale of ST products with provisions different from the statements and/or technical features set forth in this document shall immediately void any warranty granted by ST for the ST product or service described herein and shall not create or extend in any manner whatsoever, any liability of ST.

ST and the ST logo are trademarks or registered trademarks of ST in various countries.

Information in this document supersedes and replaces all information previously supplied.

The ST logo is a registered trademark of STMicroelectronics. All other names are the property of their respective owners.

© 2006 STMicroelectronics - All rights reserved

STMicroelectronics group of companies

Australia - Belgium - Brazil - Canada - China - Czech Republic - Finland - France - Germany - Hong Kong - India - Israel - Italy - Japan - Malaysia - Malta - Morocco - Singapore - Spain - Sweden - Switzerland - United Kingdom - United States of America

www.st.com

