



U74LVC74A

CMOS IC

DUAL POSITIVE-EDGE-TRIGGERED D-TYPE FLIP-FLOPS WITH CLEAR AND PRESET

DESCRIPTION

The **U74LVC74A** is a dual positive-edge-triggered D-type flip-flop.

The preset (\overline{PRE}) and clear (\overline{CLR}) input can set or reset the output, regardless of the levels of others inputs. When the \overline{PRE} and \overline{CLR} are inactive (high), data at the data input meeting the set-up time requirements is transferred to the outputs on the positive-going edge of the clock pulse. Following the hold-time interval, data D can be changed without affecting the levels at the outputs.

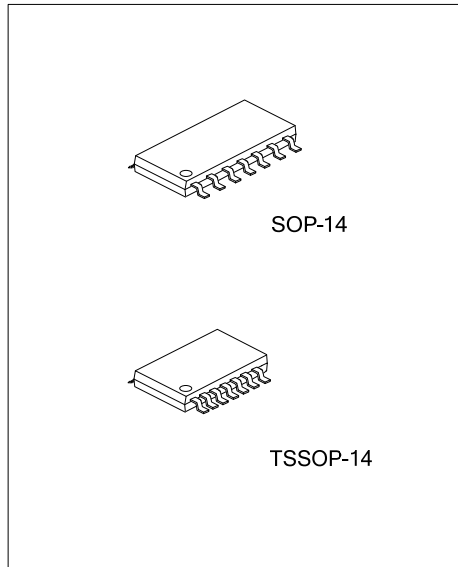

FEATURES

- * 1.65V to 3.6V V_{CC} Operation
- * Inputs Accept Voltages to 5.5V
- * Max tpd at 5.2ns of 3.3V
- * Typical $V_{OLP} < 0.8V$ at $V_{CC} = 3.3V, T_A = 25^\circ C$
- * Typical $V_{OHV} > 2V$ at $V_{CC} = 3.3V, T_A = 25^\circ C$

ORDERING INFORMATION

Ordering Number	Package	Packing
U74LVC74AG-S14-R	SOP-14	Tape Reel
U74LVC74AG-P14-R	TSSOP-14	Tape Reel

<p>U74LVC74AG-S14-R</p> <p>(1) Packing Type (2) Package Type (3) Green Package</p>	<p>(1) R: Tape Reel (2) S14: SOP-14, P14: TSSOP-14 (3) G: Halogen Free and Lead Free</p>
--	--

MARKING

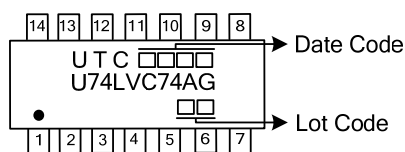

■ PIN CONFIGURATION

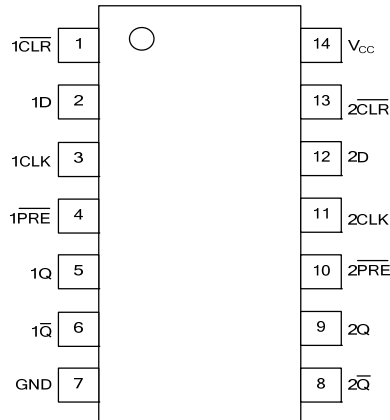

■ FUNCTION TABLE (each gate)

INPUT				OUTPUT	
PRE	CLR	CLK	D	Q	Q-bar
L	H	X	X	H	L
H	L	X	X	L	H
L	L	X	X	H ⁺	H ⁺
H	H	↑	H	H	L
H	H	↑	L	L	H
H	H	L	X	Q ₀	Q ₀ -bar

+: This configuration is unstable, as it is not persist when either PRE or CLR return to high level.

■ LOGIC DIAGRAM (positive logic)

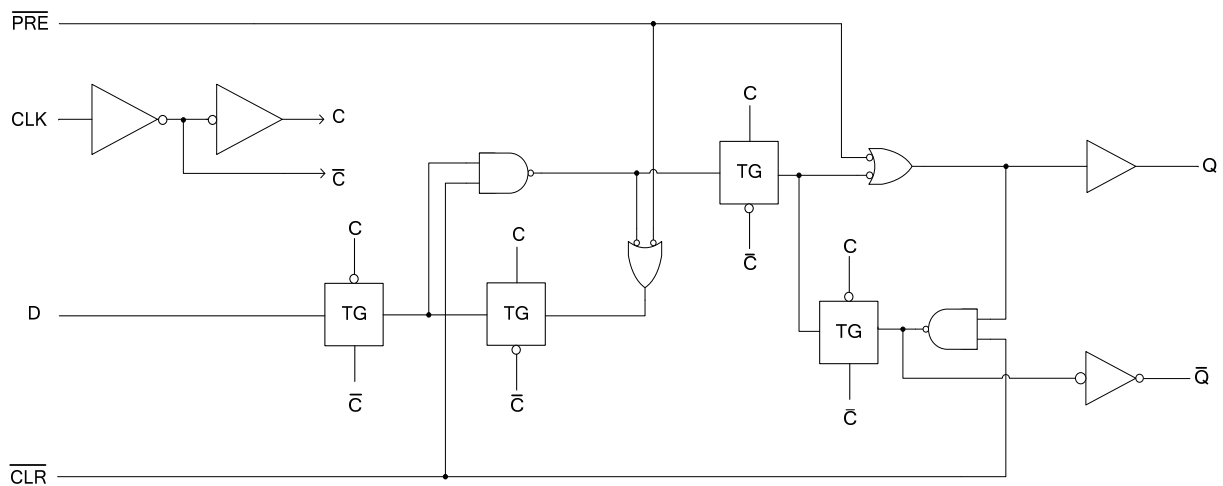

■ ABSOLUTE MAXIMUM RATING (unless otherwise specified)(Note 1)

PARAMETER	SYMBOL	RATINGS	UNIT
Supply Voltage	V_{CC}	-0.5~6.5	V
Input Voltage	V_{IN}	-0.5~ 6.5	V
Output Voltage(active mode)	V_{OUT}	-0.5~ V_{CC} +0.5	V
Input Clamp Current($V_{IN}<0$)	I_{IK}	-50(MAX)	mA
Output Clamp Current($V_{OUT}<0$)	I_{OK}	-50(MAX)	mA
Output Current	I_{OUT}	±50	mA
V_{CC} or GND Current	I_{CC}	±100	mA
Storage Temperature	T_{STG}	-65 ~ +150	°C

Notes: 1. The input and output voltage ratings may be exceeded if the input and output current ratings are observed.
 2. Absolute maximum ratings are those values beyond which the device could be permanently damaged.
 Absolute maximum ratings are stress ratings only and functional device operation is not implied.

■ RECOMMENDED OPERATING COMDITIONS

PARAMETER	SYMBOL	CONDITIONS	MIN	TYP	MAX	UNIT
Supply Voltage	V_{CC}		1.65		3.6	V
Input Voltage	V_{IN}		0		5.5	V
Output Voltage	V_{OUT}		0		V_{CC}	V
High-level input voltage	V_{IH}	$V_{CC} = 1.65V \sim 1.95V$	$0.65 \times V_{CC}$			V
		$V_{CC} = 2.3V \sim 2.7V$	1.7			
		$V_{CC} = 2.7V \sim 3.6V$	2			
Low-level input voltage	V_{IL}	$V_{CC} = 1.65V \sim 1.95V$			$0.35 \times V_{CC}$	V
		$V_{CC} = 2.3V \sim 2.7V$			0.7	
		$V_{CC} = 2.7V \sim 3.6V$			0.8	
High-level Output Current	I_{OH}	$V_{CC} = 1.65V$			-4	mA
		$V_{CC} = 2.3V$			-8	
		$V_{CC} = 2.7V$			-12	
		$V_{CC} = 3V$			-24	
Low-level Output Current	I_{OL}	$V_{CC} = 1.65V$			4	mA
		$V_{CC} = 2.3V$			8	
		$V_{CC} = 2.7V$			12	
		$V_{CC} = 3V$			24	
Input Transition Rise or Fall Rate	$\Delta t/\Delta v$				10	ns/V
Operating Temperature	T_A		-40		+85	°C

■ STATIC CHARACTERISTICS

PARAMETER	SYMBOL	TEST CONDITIONS	MIN	TYP	MAX	UNIT
High-Level Output Voltage	V_{OH}	$I_{OH}=-100\mu A$ $V_{CC}=1.65V\sim 3.6V$ $V_{CC}-0.2$				V
		$I_{OH}=-4mA$ $V_{CC}=1.65V$	1.2			
		$I_{OH}=-8mA$ $V_{CC}=2.3V$	1.7			
		$I_{OH}=-12mA$ $V_{CC}=2.7V$	2.2			
		$I_{OH}=-12mA$ $V_{CC}=3V$	2.4			
Low-Level Output Voltage	V_{OL}	$I_{OL}=100\mu A$ $V_{CC}=1.65V\sim 3.6V$			0.2	V
		$I_{OL}=4mA$ $V_{CC}=1.65V$			0.45	
		$I_{OL}=8mA$ $V_{CC}=2.3V$			0.7	
		$I_{OL}=12mA$ $V_{CC}=2.7V$			0.4	
		$I_{OL}=24mA$ $V_{CC}=3V$			0.55	
Input Leakage Current	$I_{I(LEAK)}$	$V_{CC}=0V\sim 3.6V$ $V_{IN}=5.5V$ or GND			± 5	μA
Quiescent Supply Current	I_Q	$V_{CC}=3.6V$ $V_{IN}=V_{CC}$ or GND $I_{OUT}=0$			10	μA
Additional Quiescent Supply Current	ΔI_Q	$V_{CC}=2.7V$ to $3.6V$ One input at $V_{CC}-0.6V$, Other inputs at V_{CC} or GND			500	μA
Input Capacitance	C_{IN}	$V_{CC}=3.3V$, $V_{IN}=V_{CC}$ or GND		5		pF

■ DYNAMIC CHARACTERISTICS (Input: $t_R, t_F \leq 2.5ns$; $PRR \leq 1MHz$)

PARAMETER	SYMBOL	TEST CONDITIONS	MIN	TYP	MAX	UNIT
Fclock Clock frequency	f_{CLOCK}	$V_{CC}=1.8V \pm 0.15V$			83	MHZ
		$V_{CC}=2.5V \pm 0.2V$			83	
		$V_{CC}=2.7V$			83	
		$V_{CC}=3.3V \pm 0.3V$			150	
Pulse duration	t_w	$V_{CC}=1.8V \pm 0.15V$	PRE or CLR Low	4.1		ns
			CLK High or Low	4.1		
		$V_{CC}=2.5V \pm 0.2V$	PRE or CLR Low	3.3		
			CLK High or Low	3.3		
		$V_{CC}=2.7V$	PRE or CLR Low	3.3		
			CLK High or Low	3.3		
		$V_{CC}=3.3V \pm 0.3V$	PRE or CLR Low	3.3		
			CLK High or Low	3.3		
Setup time before CLK \uparrow	t_{su}	$V_{CC}=1.8V \pm 0.15V$	Data	3.6		ns
			PRE or CLR Inactive	2.7		
		$V_{CC}=2.5V \pm 0.2V$	Data	2.3		
			PRE or CLR Inactive	1.9		
		$V_{CC}=2.7V$	Data	3.4		
			PRE or CLR Inactive	2.2		
		$V_{CC}=3.3V \pm 0.3V$	Data	3		
			PRE or CLR Inactive	2		
Hold time ,data after CLK \uparrow	t_h	$V_{CC}=1.8V \pm 0.15V$		1		ns
		$V_{CC}=2.5V \pm 0.2V$		1		
		$V_{CC}=2.7V$		1		
		$V_{CC}=3.3V \pm 0.3V$		0		

■ DYNAMIC CHARACTERISTICS

See Fig. 1 and Fig. 2 for test circuit and waveforms.

PARAMETER	SYMBOL	TEST CONDITIONS	MIN	TYP	MAX	UNIT
Maximum Clock Pulse Frequency	f_{max}	$V_{CC}=1.8V\pm0.15V$	83			MHz
		$V_{CC}=2.5V\pm0.2V$	83			
		$V_{CC}=2.7V$	83			
		$V_{CC}=3.3V\pm0.3V$	150			
Propagation delay from input (CLK) to output(Q or Q)	t_{PLH}/t_{PHL}	$V_{CC}=1.8V\pm0.15V, C_L=30pF, R_L=1K\Omega$	1		7.1	ns
		$V_{CC}=2.5V\pm0.2V, C_L=30pF, R_L=500\Omega$	1		4.4	
		$V_{CC}=2.7V, C_L=50pF, R_L=500\Omega$	1		6	
		$V_{CC}=3.3V\pm0.3V, C_L=50pF, R_L=500\Omega$	1		5.2	
Propagation delay from input (\overline{PRE} or \overline{CLR}) to output(Q or Q)	t_{PLH}/t_{PHL}	$V_{CC}=1.8V\pm0.15V, C_L=30pF, R_L=1K\Omega$	1		6.9	ns
		$V_{CC}=2.5V\pm0.2V, C_L=30pF, R_L=500\Omega$	1		4.6	
		$V_{CC}=2.7V, C_L=50pF, R_L=500\Omega$	1		6.4	
		$V_{CC}=3.3V\pm0.3V, C_L=50pF, R_L=500\Omega$	1		5.4	

■ OPERATING CHARACTERISTICS

PARAMETER	SYMBOL	TEST CONDITIONS	MIN	TYP	MAX	UNIT
Power Dissipation Capacitance	C_{PD}	$V_{CC}=1.8V, f=10MHz$	24			pF
		$V_{CC}=2.5V, f=10MHz$	24			pF
		$V_{CC}=3.3V, f=10MHz$	26			pF

■ TEST CIRCUIT AND WAVEFORMS

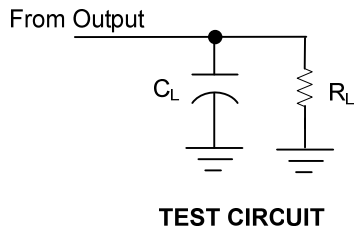

Note: C_L includes probe and jig capacitance.

Fig. 1 Load circuitry for switching times.

V_{CC}	Inputs		V_M	C_L	R_L
	V_{IN}	t_R, t_F			
$1.8V \pm 0.15V$	V_{CC}	$\leq 2ns$	$V_{CC}/2$	30pF	1K Ω
$2.5V \pm 0.2V$	V_{CC}	$\leq 2ns$	$V_{CC}/2$	30pF	500 Ω
2.7V	2.7V	$\leq 2.5ns$	1.5V	50pF	500 Ω
$3.3V \pm 0.3V$	2.7V	$\leq 2.5ns$	$V_{CC}/2$	50pF	500 Ω

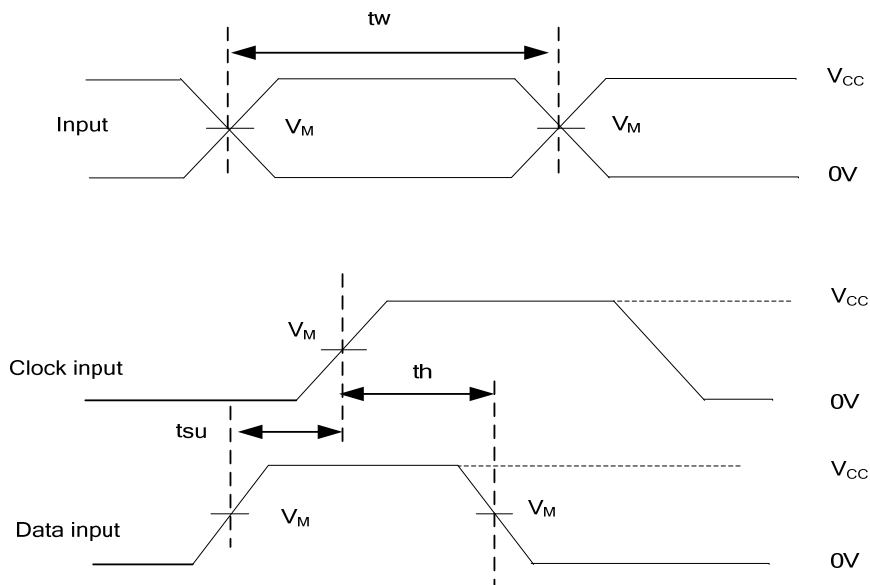

Fig. 2 Propagation delay from input to output and input voltage waveforms.

■ TEST CIRCUIT AND WAVEFORMS(Cont.)

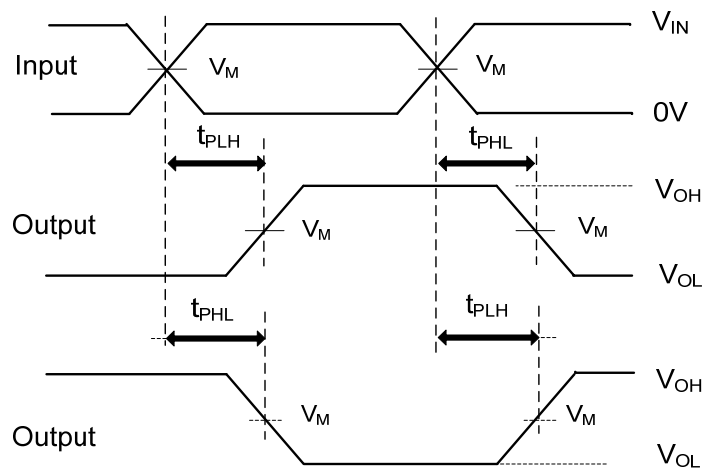

Fig. 3 PROPAGATION DELAY TIMES

UTC assumes no responsibility for equipment failures that result from using products at values that exceed, even momentarily, rated values (such as maximum ratings, operating condition ranges, or other parameters) listed in products specifications of any and all UTC products described or contained herein. UTC products are not designed for use in life support appliances, devices or systems where malfunction of these products can be reasonably expected to result in personal injury. Reproduction in whole or in part is prohibited without the prior written consent of the copyright owner. The information presented in this document does not form part of any quotation or contract, is believed to be accurate and reliable and may be changed without notice.